

20 W dimmable CFL ballast solution

Introduction

This application note describes the 20 W dimmable CFL ballast solution which can completely replace incandescent lamps in formal dimming systems. The dimmer controlled range is 20% - 100% of full light output without changing the formal triac dimmer.

Compared to the formal CFL solution, this solution not only provides energy savings, but also higher reliability and a much longer operating life.

The solution is based on the high performance ballast driver L6574D, two of the STD4NK50Z Zener protected SuperMESH™ Power MOSFETs, and two of the STTH1L06 turbo 2 ultra fast high voltage rectifiers.

Figure 1. Typical dimmer

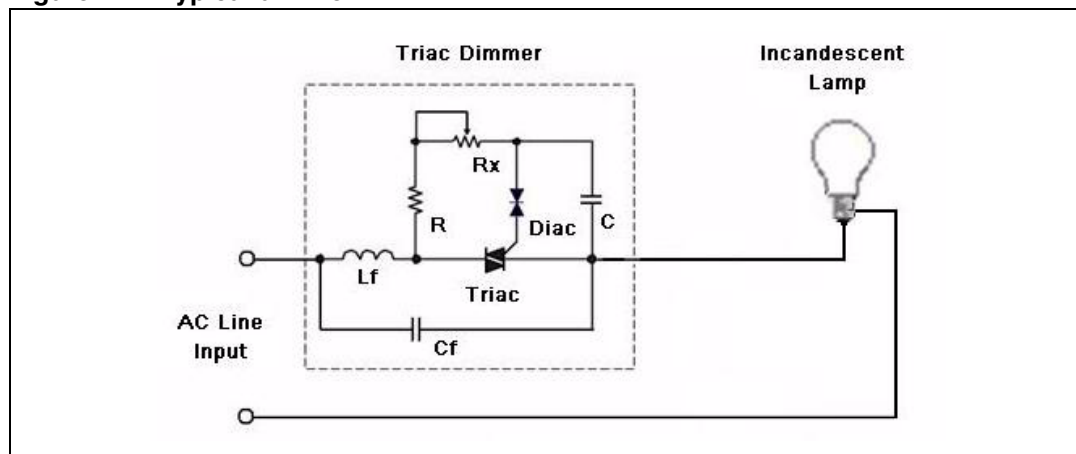
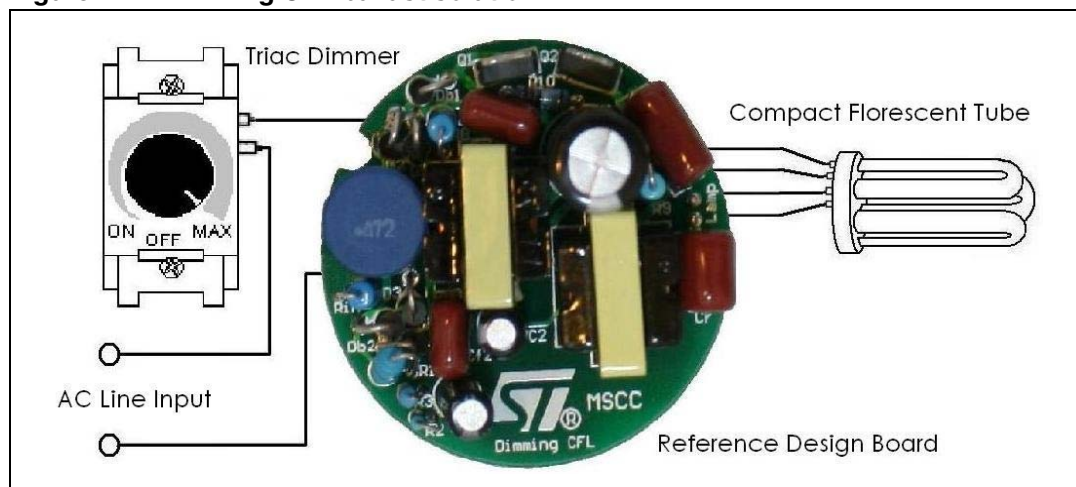

Figure 2. Dimming CFL ballast solution



Contents

- 1 Typical dimming system for incandescent lamps 4**
 - 1.1 Formal CFL ballast and its disadvantages 4
 - 1.2 Proposed solution 5

- 2 Board description 6**
 - 2.1 Application circuit 6
 - 2.2 Dimming function 7
 - 2.3 Principle of the main circuit 7
 - 2.4 Calculations 8

- 3 Electrical specifications and reference design board 10**
 - 3.1 Electrical specifications 10
 - 3.2 PCB layout view 10

- 4 Test results 11**

- 5 Conclusion 14**
 - 5.1 References 14

- 6 Revision history 16**

List of figures

Figure 1.	Typical dimmer	1
Figure 2.	Dimming CFL ballast solution	1
Figure 3.	Typical dimming system consisting of incandescent lamp and triac dimmer	4
Figure 4.	Block diagram of formal CFL ballast	4
Figure 5.	The half AC line cycle of sinuous wave and firing angle	5
Figure 6.	Schematic of the reference design board	6
Figure 7.	Main circuit	7
Figure 8.	L1 current per switching period	8
Figure 9.	L1 current shape	8
Figure 10.	PCB top-side view	10
Figure 11.	PCB bottom-side view	10
Figure 12.	Full load efficiency vs. AC line input	11
Figure 13.	Triac turn-on time vs. power dissipation to the lamp	11
Figure 14.	AC input voltage and current	12
Figure 15.	L1 voltage and current	12
Figure 16.	Power factor in operating range	12
Figure 17.	Lamp voltage and current at $T_{on}=9$ ms, $V_{lamp}=100$ V/div, $I_{lamp}= 200$ mA/div	13
Figure 18.	Lamp voltage and current at $T_{on}=5$ ms, $V_{lamp}=100$ V/div, $I_{lamp}= 200$ mA/div	13
Figure 19.	Lamp voltage and current at $T_{on}=3$ ms, $V_{lamp}=100$ V/div, $I_{lamp}= 200$ mA/div	13

1 Typical dimming system for incandescent lamps

A typical dimming system consists of the lamp(s) and dimmer (*Figure 3*). The dimmer consists of the triac and a few components, see *Figure 1*. Dimmers of this type are appropriate for incandescent lamps and are very popular in the market.

Figure 3. Typical dimming system consisting of incandescent lamp and triac dimmer

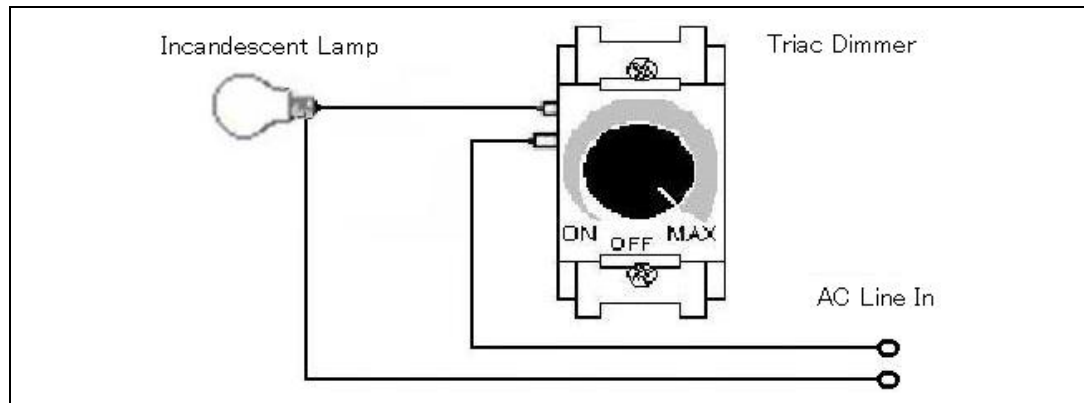

The triac conducts once it has been triggered and holds latching current. The triac shuts down when the current is less than the holding current. The dimmer works fine with a resistive load. The triac can be triggered at any timing of the sinuous voltage (AC line input), and can be kept in conduction state until reaching zero line voltage. This allows the lamp to be dimmed nearly to 100%.

1.1 Formal CFL ballast and its disadvantages

Since the formal CFL is not a resistive load, the ballast has no power factor correction circuit (PFC). If the incandescent lamp (Tungsten filament light bulb) is replaced by a formal CFL (Compact Florescent Lamp) directly, the CFL cannot fully illuminate and may have intermittant blinking or no light at all. *Figure 4* shows the block diagram of a formal CFL.

Figure 4. Block diagram of formal CFL ballast

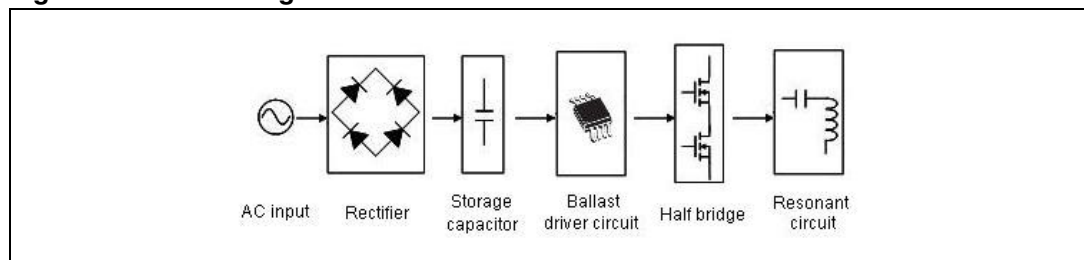

The formal CFL ballast consists of a rectifier, storage capacitor, ballast driver circuit, half bridge and resonant circuit. The source energy stored only to the storage capacitor from the AC input at the timing nears its peak voltage per half cycle. When the formal CFL ballast is connected to the triac dimmer (see *Figure 1*), the triac conducts only after having been triggered, that is, when the rectified voltage is higher than the voltage across the storage capacitor. At this extreme moment the capacitor can be charged with the same peak from

the AC input, and the triac is then immediately turned off. It is impossible to adjust the DC voltage across the storage capacitor and then extend triac firing angle less than 90° . However the lamp may continue to flicker and remain unstable if the DC voltage is not well managed.

1.2 Proposed solution

The CFL ballast has been developed based on the L6574D. The lamp power can be dimmed from below 20% up to 100% (full illumination) by adjusting the triac dimmer.

With the implementation of the PFC solution, the lamp power can be adjusted by switching the frequency of the driver circuit that corresponds to the illumination level set by the triac dimmer. The triac can be triggered at every point during the half cycle and conducts continuously until the end of the half cycle (180°). In addition, a circuit detects the firing angle of the triac and adjusts lamp power by adjusting the switching frequency of the half bridge to control lamp power depending on the position of the triac dimmer.

Please note that while the triac dimmer is connected to the capacitive load (CFL), the triac will not be fired if trigger angle is set lower than 50° . Because bus voltage (the voltage across the storage capacitor) falls, the system stops operating at an angle less than 40° . For this reason, the dimmable ballast cannot be operated in full dimming range. A hysteric range per half AC cycle was turned on at 50° and turned off at 40° . [Figure 5](#) shows us the Gate pulse (trigger) and firing angle per half cycle.

Figure 5. The half AC line cycle of sinuous wave and firing angle

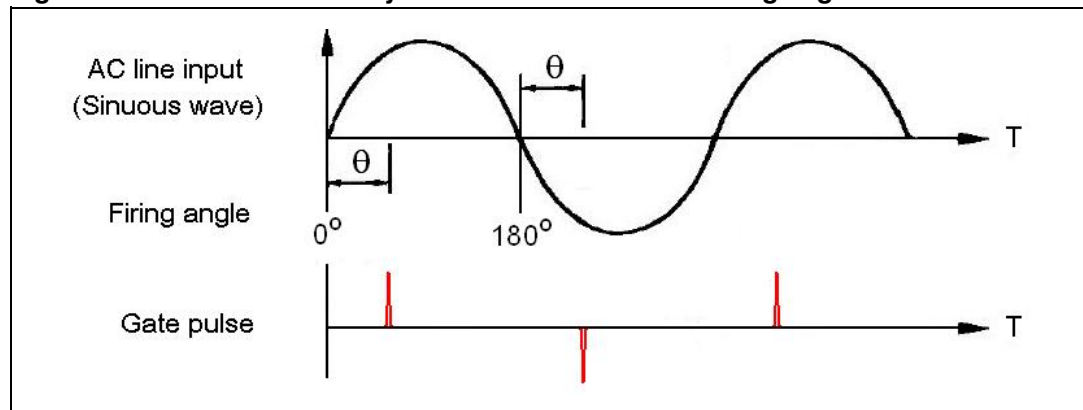

2 Board description

2.1 Application circuit

The reference design board is made according to the schematic shown in [Figure 6](#). It includes an LC filter, bridge rectifier, single stage PFC with high frequency ballast driver and resonant circuit.

Figure 6. Schematic of the reference design board

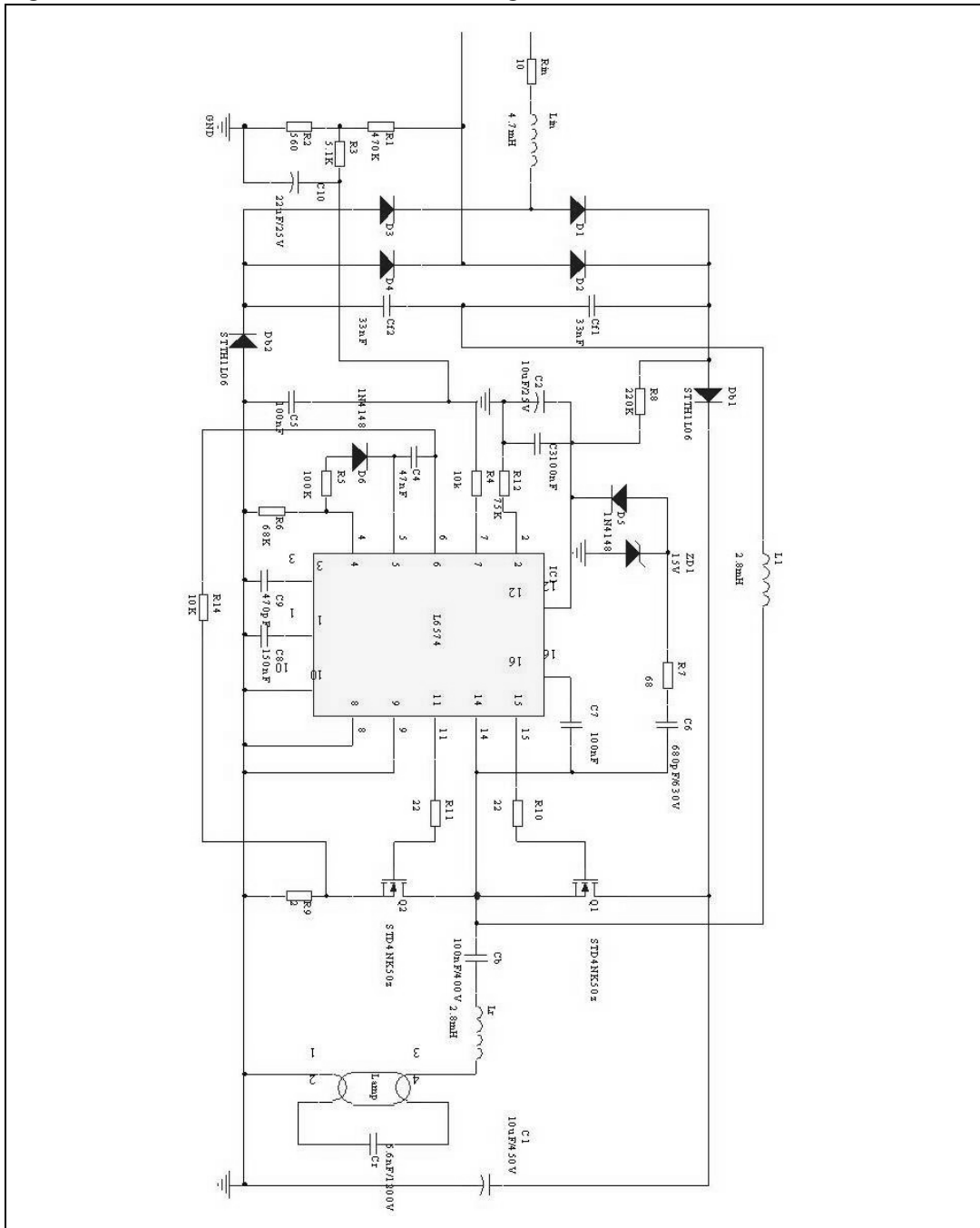

2.2 Dimming function

The two modes for dimming function are frequency modulation and voltage modulation.

In this solution, the dimming function is obtained using two methods: frequency modulation and voltage modulation. When the trigger angle of the triac changes from 0° to 90° , only frequency modulation works. When the angle changes from 90° to 180° , both of them work, and voltage modulation dominates.

Frequency modulation depends on the operational amplifier in L6574D. In [Figure 6](#), R1, R2, R3 and C10 were used to simulate the trigger angle of the triac. When the angle changes from 0° to 180° , the voltage across C10 which is the positive input of the amplifier (Pin 7, here pin number is for L6574D), decreases accordingly. The output (Pin 5) of the amplifier decreases with Pin 7, and the negative input (Pin 6) of the amplifier automatically decreases. The equivalent resistance between Pin 4 and GND of the IC decreases, so the switching frequency increases, hence lamp power decreases. If the angle changes from 180° to 360° , lamp power increases.

Voltage modulation means that the voltage across C1 (see [Figure 6](#)) decreases when the firing angle of the triac changes from 90° to 180° . This makes the lamp power decrease.

2.3 Principle of the main circuit

In order to simplify the analysis, the main circuit is shown in [Figure 7](#). There are two independent circuits, power factor correction (PFC) circuit and half bridge resonant circuit. The PFC which is labeled as A (dotted line) consists of Cf1, Cf2, L1, Db1, Db2, S1, S2 and C1. The other one is a half bridge resonant circuit, which is labeled as B (solid line). It consists of C1, S1, S2, Cb, Lr, Cr and the Lamp. S1 and S2, the Power MOSFETs operate complementarily at almost 0.5 duty ratio.

Figure 7. Main circuit

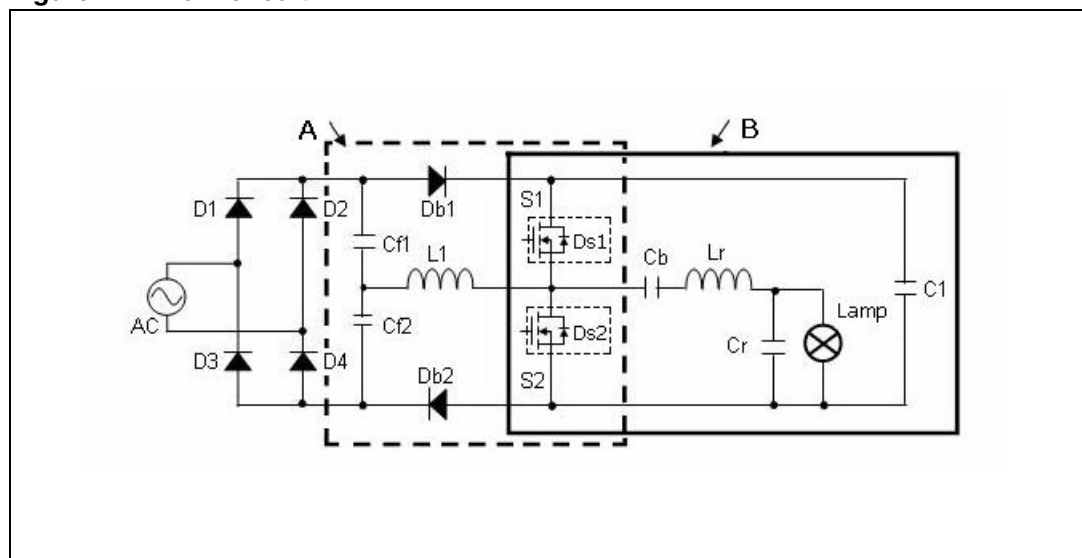

Since the switching frequency was high enough, the voltages across the divider capacitors (Cf1&Cf2) can be treated as constant during one switching cycle. Thus the voltage across C1 is always higher than the line peak. In [Figure 8](#) per switching cycle shows the model of a four stage current flow through L1.

- Stage 1: [t0... t1] charge to L1. At t0, S1 is already turned on and S2 is off. Assume the current through L1 (iL1) is zero, then iL1 increases linearly by the voltage across Cf1, and the current flows through Cf1, Db1, S1 and L1.
- Stage 2: [t1... t2] discharging by L1. At t1, S1 is turned off and S2 is turned on. At the moment iL1 reaches the positive peak that forces Ds2 to turn on, negative voltage (Vc1-Vcf1) is applied to L1, causing iL1 to decrease linearly. The current flows through Cf1, Db1, C1, Ds2 and L1.
- Stage 3: [t2... t3] charge to L1. At t2, iL1 reaches zero, and iL1 linearly increases to the negative peak by the voltage across Cf2. The current flows through Cf2, L1, S2 and Db2.
- Stage 4: [t3... t4] discharging by L1. At t3, S1 is turned on and S2 is turned off. When iL1 reaches the negative peak that forces Ds1 to turn on, voltage (Vc1-Vcf2) is applied to L1, causing iL1 to decrease linearly. The current flows through Cf2, L1, Ds1, C1 and Db2. At t4, iL1 reaches zero, where the new switching cycle begins.

Figure 8. L1 current per switching period

Figure 9. L1 current shape

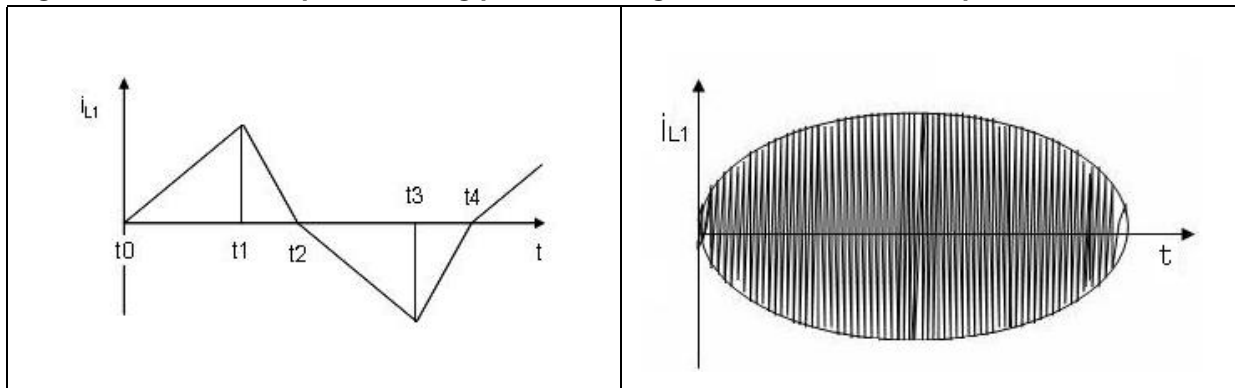

The overall current flow shape in L1 during one half AC line cycle is shown in [Figure 9](#). It is clear that the boost inductor current flows in two directions and the PFC circuit works at boundary conduction mode.

2.4 Calculations

From the above analysis, the main parameters of the circuit can be calculated for the application. To design the PFC circuit, the inductor (L1) and its peak current (Ipk) are the most important.

For the resonant circuit, Lr and Cr are the main parameters. The calculation steps are given as follows:

- Step 1: Ipk during one switching cycle is given by,

Equation 1

$$I_{pk} = \frac{\frac{1}{2}V_{in} \cdot \left(\frac{1}{2}T_s - t'\right)}{L1} = \frac{V_{c1} - \frac{1}{2}V_{in} \cdot t'}{L1}$$

Where Vin is the input voltage after rectifier, Ts is the period of a switching time, t' is the discharging time of L1, and Vc1 is the voltage across C1.

As a consequence of that, we have the following.

Equation 2

$$t' = \frac{V_{in}}{4V_{c1}} T_s$$

Equation 3

$$I_{pk} = \frac{T_s}{4L_1} \cdot \left(1 - \frac{V_{in}}{2V_{c1}}\right) \cdot V_{in}$$

- Step 2: The input ac current (I_{ac}) equals half of the average inductor current due to two divider capacitors, so,

Equation 4

$$I_{ac} = \left(\frac{1}{2}i_{L1}\right)_{ave} = \frac{1}{4}I_{pk} = \frac{T_s}{16L_1} \cdot \left(1 - \frac{V_{in}}{2V_{c1}}\right) \cdot V_{in}$$

- Step 3: The input power P_{in} is determined by,

Equation 5

$$P_{in} = \frac{1}{\pi} \int_0^{\pi} V_{ac} \cdot I_{acd} \theta$$

Where V_{ac} is the input voltage. With the above three steps, the values of L_1 and I_{pk} can be found if the input/output conditions and switching frequency are given.

- Step 4: For the half bridge resonant circuit, the equivalent resistance of the lamp is given by:

Equation 6

$$R_{lamp} = \frac{V_{rms, lamp}}{I_{rms, lamp}}$$

Where $V_{rms, lamp}$ is the rated lamp voltage, $I_{rms, lamp}$ is the rated lamp current. With $V_{rms, lamp}$ and $I_{rms, lamp}$ and the input voltage of the half bridge (V_{c1}), the results of L_r & C_r are easily obtained.

- Step 5: MOSFET selection. In order to select an adequate MOSFET parameters $V_{(BR)DSS}$, I_D and R_{DSON} are important. The $V_{(BR)DSS}$ should be selected according to V_{c1} with a certain safe margin. In a compact application, the thermal issue becomes very critical. Thus I_D and R_{DSON} must be selected with a safe margin also.

3 Electrical specifications and reference design board

3.1 Electrical specifications

The electrical specifications of the reference design board are shown in [Table 1](#).

Table 1. Electrical specifications of evaluation board⁽¹⁾

Parameter	Value			Unit
	Min.	Typical	Max.	
AC input (operating range)	180	220	260	V
Line frequency	~	50	~	Hz
Load (3U compact florescent lamp)	~	20	~	W
Rated switching frequency (pin14 of L6974D)	~	44	~	kHz
Minimum dimmable lamp power	~	2.7	3	W
Maximum dimmable lamp power	16.4	16.6	~	W
Lamp power without connection to triac dimmer	19.25	20	20.75	W
Power factor	0.9	0.92	~	~

1. The test under AC input 220 V/50 Hz at room temperature

3.2 PCB layout view

The PCB layout of the board is shown below. [Figure 10](#) shows the PCB top side view and [Figure 11](#) shows the PCB bottom side view.

Figure 10. PCB top-side view

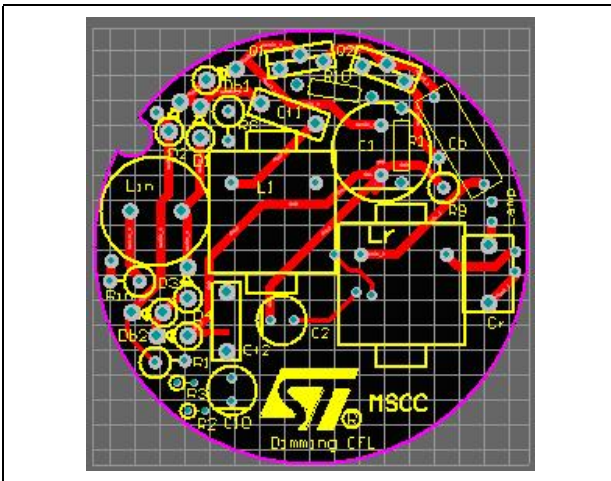
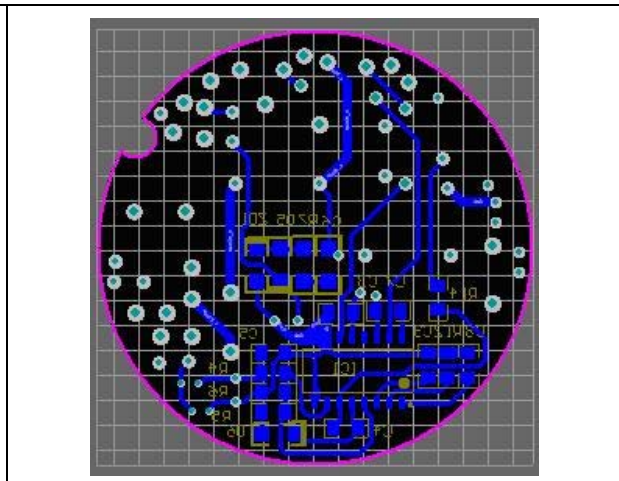

Figure 11. PCB bottom-side view



4 Test results

The evaluation results include the ballast system efficiency and the dimming characteristics and performance of the power factor of the reference design board in addition to more typical waveforms for evaluation boards.

The efficiency at full load in operating input voltage was higher than 80%, see [Figure 12](#).

Figure 12. Full load efficiency vs. AC line input

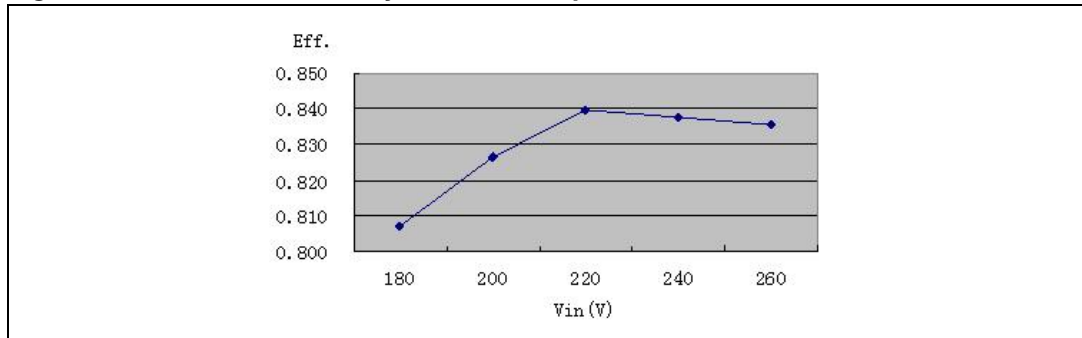

The triac turn on time per half cycle relates to the power dissipation of the lamp. The system is operating at 220 V_{AC}/50 Hz. Hence the maximum half cycle time is 10 ms. Theoretically, the range of T_{on} is 10 ms to 0ms corresponding to the firing angle 0° to 180°. But under real conditions the range of T_{on} is about 9 ms to 2 ms, see [Figure 13](#).

Figure 13. Triac turn-on time vs. power dissipation to the lamp

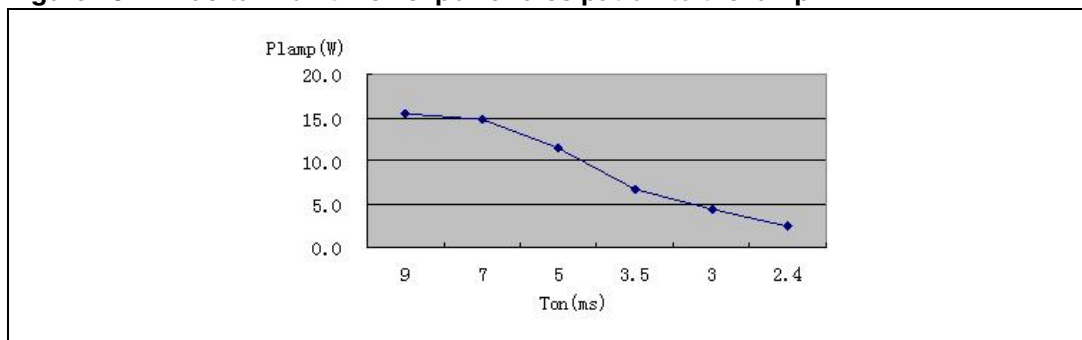

[Figure 14](#) shows the input voltage and current at maximum turn-on time of the triac. A glitch (circled on the waveform) always exists at each half cycle of the input voltage. A current spike (circled on the waveform) occurs at each half cycle when line voltage reaches the peak. Although it is not good for the power factor, it is suitable for this application as it ensures that the voltage on C1 is not higher than the peak of the input voltage.

Figure 14. AC input voltage and current

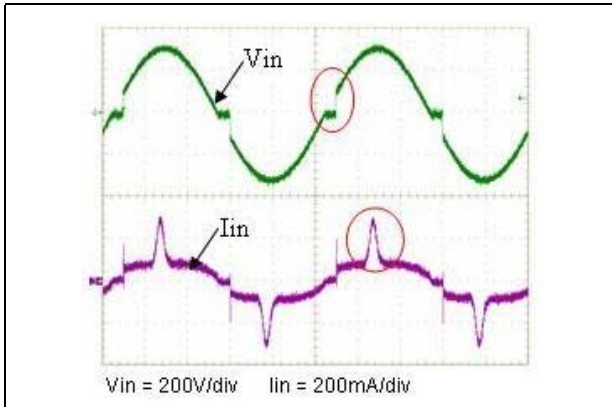

Figure 15. L1 voltage and current

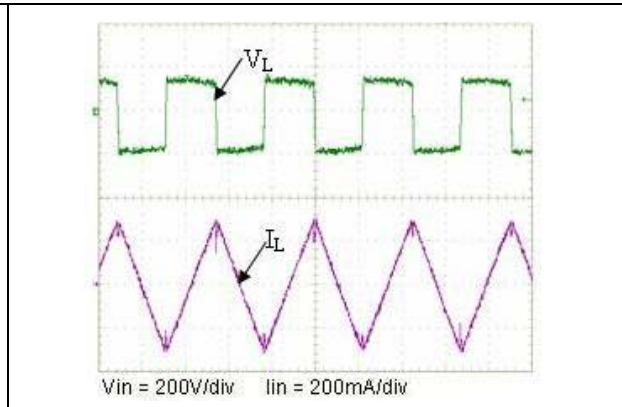
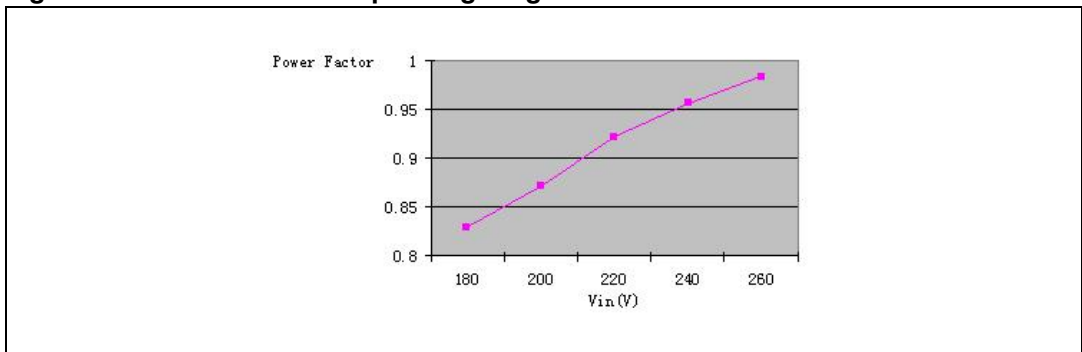

Figure 15 shows the voltage and current waveform of the boost inductor L1. The glitch could happen while L1 works in two directions at critical conduction mode.

Although the glitch was there, due to the limitation of maximum T_{on} , the power factor is always higher than 0.8 in operating range. Please refer to Figure 16 below.

Figure 16. Power factor in operating range



The different T_{on} to triac in the dimming control circuit provides the different power dissipation to the lamp. The figures also show the negative resistance characteristics of the lamp, such as when the lamp current decreases, the voltage increases accordingly.

Figure 17, shows us the voltage and current measurement at T_{on} equal to 9 ms. Figure 18, shows us the voltage and current measurement at T_{on} equal to 5 ms. Figure 19 shows us the voltage and current measurement at T_{on} equal to 3 ms.

Figure 17. Lamp voltage and current at $T_{on}=9\text{ ms}$, $V_{lamp}=100\text{ V/div}$, $I_{lamp}=200\text{ mA/div}$

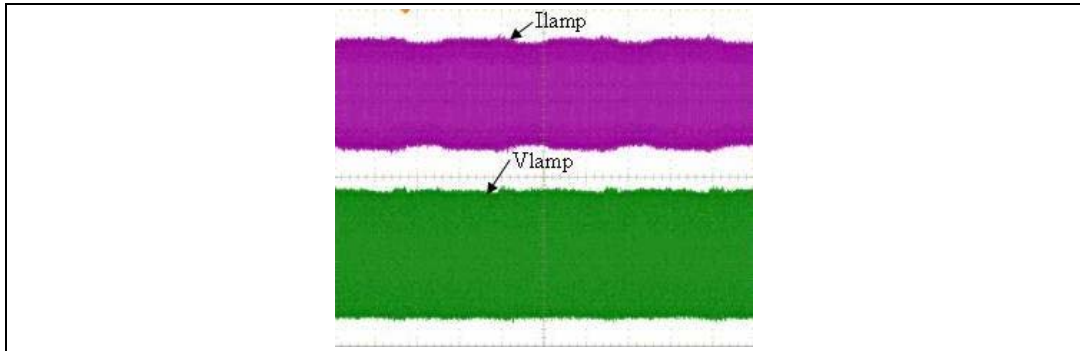

Figure 18. Lamp voltage and current at $T_{on}=5\text{ ms}$, $V_{lamp}=100\text{ V/div}$, $I_{lamp}=200\text{ mA/div}$

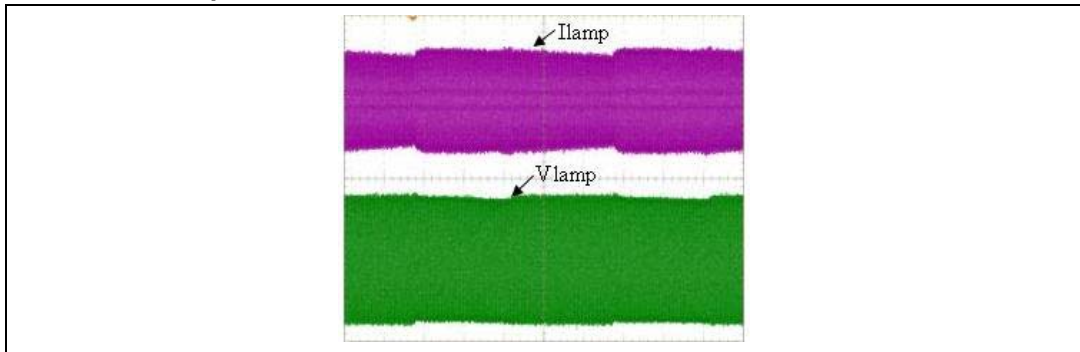
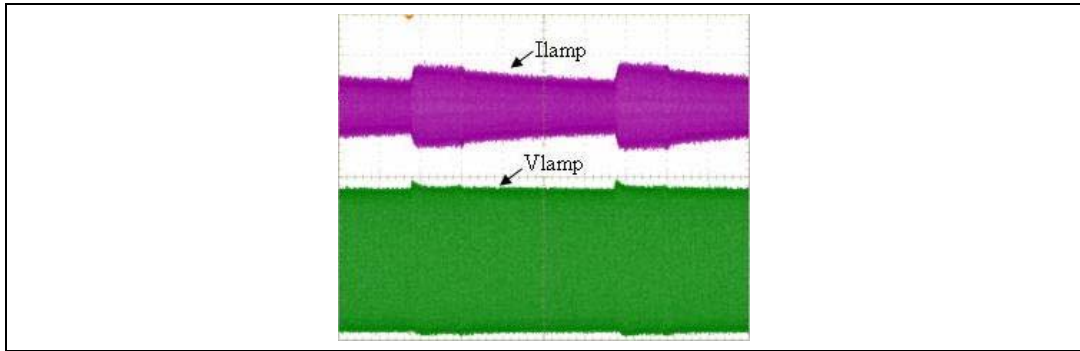

Figure 19. Lamp voltage and current at $T_{on}=3\text{ ms}$, $V_{lamp}=100\text{ V/div}$, $I_{lamp}=200\text{ mA/div}$



5 Conclusion

A dimmable CFL solution has been discussed and analyzed. CFLs can completely replace incandescent lamps in dimming systems. With a dimming range of 20%-100%, CFLs are very energy efficient and have a reliable and longer lifetime. The efficiency is above 80% which makes this solution suitable in compact applications.

5.1 References

1. L6574D Datasheet CFL/TL ballast driver preheat and dimming
2. AN993, the application note of electronic ballast with PFC using L6574 and L6561

Appendix A Bill of material

Table 2. Bill of material

Symbol	Value	Note
R1	470 k Ω	0.5 W
R2	560 Ω	
R3	5.1 k Ω	
R4	10 k Ω	
R5	100 k Ω	
R6	68 k Ω	
R7	68 Ω	
R8	180 k Ω	0.5 W
R9	2 Ω	0.5 W
R10	22 Ω	
R11	22 Ω	
R12	75 k Ω	
R14	10 k Ω	
Rin	10 Ω	
C1	10 μ F	450 V, Electrolytic
C2	22 μ F	25 V, Electrolytic
C3	100 nF	
C4	8.2 nF	
C5	100 nF	
C6	680 pF	C3216C0G2J681J, TDK
C7	100 nF	
C8	150 nF	
C9	27 pF	
C10	22 μ f	25 V, Electrolytic
Cf1, Cf2	33 nF	400 V, CBB
Cb	100 nF	400 V, CBB
Cr	5.6 nF	1 kV, ceramic
Lin	4.7 mH	TSL1112-472JR21, TDK
L1, Lr	2.8 mH	See Table 3
D1 – D4	1N4007	
D5 – D6	1N4148	
Db1, Db2	STTH1L06	the turbo 2 ultra fast high voltage rectifiers, STMicroelectronics

Table 2. Bill of material (continued)

Symbol	Value	Note
ZD1	15V	
Q1, Q2	STD4NK50Z	Zener protected SuperMESH™ Power MOSFET, STMicroelectronics
IC1	L6574D	high performance ballast driver, STMicroelectronics

Table 3. Specification of inductors - "L1" and "Lr"

Key item	Used type
Core	PC40EE16-Z or equivalent
Bobbin	BE16-116CPFR
Winding	AWG34 * 200 turns
Air gap	~ 0.3 mm on each leg for the inductance of 2.8 mH

6 Revision history

Table 4. Document revision history

Date	Revision	Changes
08-Oct-2007	1	First release

Please Read Carefully:

Information in this document is provided solely in connection with ST products. STMicroelectronics NV and its subsidiaries ("ST") reserve the right to make changes, corrections, modifications or improvements, to this document, and the products and services described herein at any time, without notice.

All ST products are sold pursuant to ST's terms and conditions of sale.

Purchasers are solely responsible for the choice, selection and use of the ST products and services described herein, and ST assumes no liability whatsoever relating to the choice, selection or use of the ST products and services described herein.

No license, express or implied, by estoppel or otherwise, to any intellectual property rights is granted under this document. If any part of this document refers to any third party products or services it shall not be deemed a license grant by ST for the use of such third party products or services, or any intellectual property contained therein or considered as a warranty covering the use in any manner whatsoever of such third party products or services or any intellectual property contained therein.

UNLESS OTHERWISE SET FORTH IN ST'S TERMS AND CONDITIONS OF SALE ST DISCLAIMS ANY EXPRESS OR IMPLIED WARRANTY WITH RESPECT TO THE USE AND/OR SALE OF ST PRODUCTS INCLUDING WITHOUT LIMITATION IMPLIED WARRANTIES OF MERCHANTABILITY, FITNESS FOR A PARTICULAR PURPOSE (AND THEIR EQUIVALENTS UNDER THE LAWS OF ANY JURISDICTION), OR INFRINGEMENT OF ANY PATENT, COPYRIGHT OR OTHER INTELLECTUAL PROPERTY RIGHT.

UNLESS EXPRESSLY APPROVED IN WRITING BY AN AUTHORIZED ST REPRESENTATIVE, ST PRODUCTS ARE NOT RECOMMENDED, AUTHORIZED OR WARRANTED FOR USE IN MILITARY, AIR CRAFT, SPACE, LIFE SAVING, OR LIFE SUSTAINING APPLICATIONS, NOR IN PRODUCTS OR SYSTEMS WHERE FAILURE OR MALFUNCTION MAY RESULT IN PERSONAL INJURY, DEATH, OR SEVERE PROPERTY OR ENVIRONMENTAL DAMAGE. ST PRODUCTS WHICH ARE NOT SPECIFIED AS "AUTOMOTIVE GRADE" MAY ONLY BE USED IN AUTOMOTIVE APPLICATIONS AT USER'S OWN RISK.

Resale of ST products with provisions different from the statements and/or technical features set forth in this document shall immediately void any warranty granted by ST for the ST product or service described herein and shall not create or extend in any manner whatsoever, any liability of ST.

ST and the ST logo are trademarks or registered trademarks of ST in various countries.

Information in this document supersedes and replaces all information previously supplied.

The ST logo is a registered trademark of STMicroelectronics. All other names are the property of their respective owners.

© 2007 STMicroelectronics - All rights reserved

STMicroelectronics group of companies

Australia - Belgium - Brazil - Canada - China - Czech Republic - Finland - France - Germany - Hong Kong - India - Israel - Italy - Japan - Malaysia - Malta - Morocco - Singapore - Spain - Sweden - Switzerland - United Kingdom - United States of America

www.st.com