



Protection of automotive electronics from electrical hazards,
guidelines for design and component selection

Introduction

Electronic equipment represents a large part of the automobiles of today. Although these electronic modules bring much more comfort and security for the vehicle user, they also bring significant concerns in terms of reliability regarding the automobile environment.

Because electronic modules are sensitive to electromagnetic disturbances (EMI), electrostatic discharges (ESD) and other electrical disturbances (and automobiles are the source of many such hazards), caution must be taken wherever electronic modules are used in the automotive environment.

Several standards have been produced to model the electrical hazards that are currently found in automobiles. As a result manufacturers and suppliers have to consider these standards and have to add protection devices to their modules to fulfill the major obligations imposed by these standards.

The objective of this document is to help electronic module designers with a protection design approach for selecting the most suitable devices for typical applications depending on the protection standard the electronic module has to meet.

[Section 1](#) describes the electrical hazards considered in this document. [Section 2](#) presents a list of parameters to be taken into account before selecting possible protection devices. [Section 3](#) and [Section 4](#) provide worked design examples, with design calculations, for several protection solutions. [Section 5](#) provides recommendations for the design of PCB layout for improved solutions.

Transil is a trademark of STMicroelectronics.

Contents

1	Electrical hazards in the automotive environment	4
1.1	Source of hazards	4
1.1.1	Conducted hazards	4
1.1.2	Radiated hazards	4
1.2	Propagation of electrical hazards	5
1.2.1	Propagation on the data lines	5
1.2.2	Hazards on the supply rail	6
1.3	Standards for the protection of automotive electronics	7
2	Parameters to consider in selecting protection devices	8
3	Data line protection	9
3.1	Protection topologies	9
3.1.1	Clamping topology	9
3.1.2	Rail-to-rail topology	10
3.2	Data line protection example	12
3.3	Design calculation example	14
3.3.1	Determination of R_d	14
3.3.2	Power dissipation determination	16
4	Supply rail protection	21
4.1	Protection topology	21
4.1.1	Clamping topology	21
4.2	Supply rail protection example 1: pulse 2 ISO 7637-2	21
4.3	Calculations for example 1	23
4.3.1	Determination of R_d	23
4.3.2	Power dissipation determination	24
4.3.3	Junction temperature determination	26
4.4	Supply rail protection example 2: pulse 5a load dump ISO 7637-2	28
4.5	Calculations for example 2	29
4.5.1	Determination of R_d	30
4.5.2	Power dissipation determination	31

5 PCB layout recommendations 33

5.1 Parasitic inductances of the Transil and the PCB tracks 33

5.1.1 Parasitic inductance from Transil wiring 33

5.1.2 Capacitive and inductive coupling 37

5.1.3 Parasitic coupling due to the loop-effect 39

6 Conclusion 40

7 Revision history 41

1 Electrical hazards in the automotive environment

The automotive environment is the source of many electrical hazards. These hazards, such as electromagnetic interference, electrostatic discharges and other electrical disturbances are generated by various accessories like ignition, relay contacts, alternator, injectors, SMPS (i.e. HID front lights) and other accessories.

These hazards can occur directly in the wiring harness in case of conducted hazards, or be applied indirectly to the electronic modules by radiation. These generated hazards can impact the electronics in two ways - either on the data lines or on the supply rail wires, depending on the environment.

1.1 Source of hazards

1.1.1 Conducted hazards

These hazards occur directly in the cable harness. They are generated by inductive loads like electro-valves, solenoids, alternators, etc.

The schematic in *Figure 1* shows a typical configuration.

Figure 1. Conducted hazards

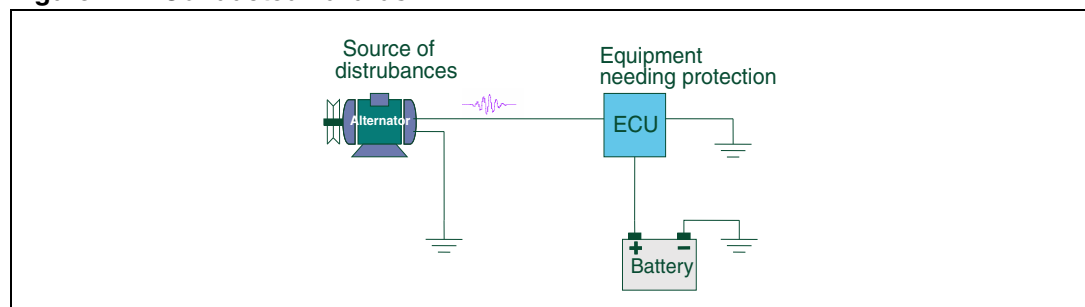

1.1.2 Radiated hazards

These hazards are generated by high current switching like relay contact, high current MOS or IGBT switches, ignition systems, etc. The electromagnetic field generated by these circuits directly affects lines or modules near the source of the electromagnetic radiation.

The schematic diagram in *Figure 2* indicates how electromagnetic radiation creates such hazards as electromagnetic interference in electronic modules.

Figure 2. Electromagnetic radiation in the automotive environment

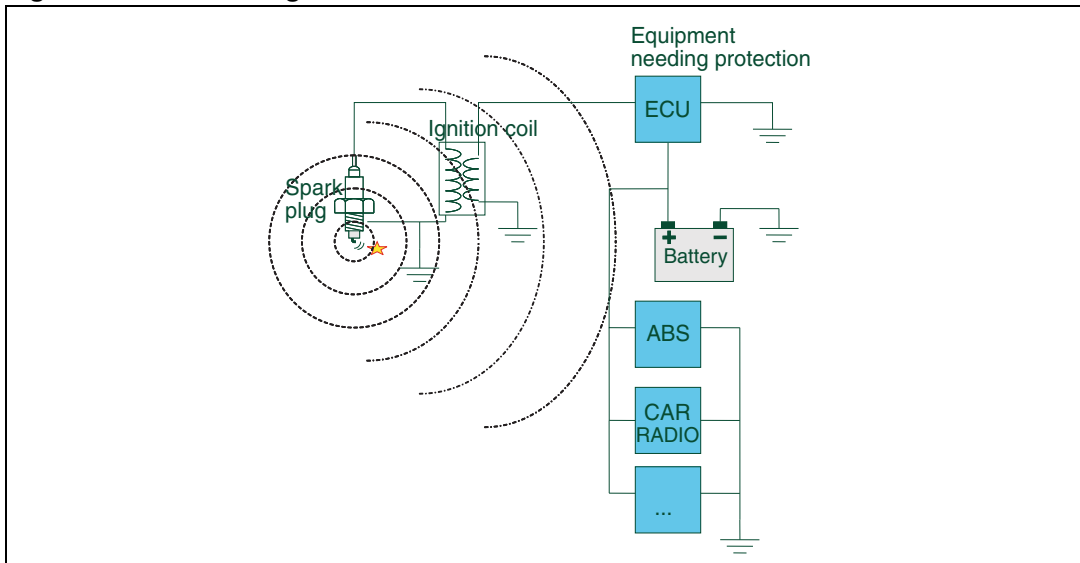

1.2 Propagation of electrical hazards

1.2.1 Propagation on the data lines

Transients that are generated on data lines are mainly ESD surges which are low energy but very high dv/dt and can generate a very strong electromagnetic field. These mainly concern ISO 10605 and IEC 61000-4-2 standards.

The data lines concerned are communication lines like media transfer lines, data buses, sensor data lines and so on.

Figure 3 shows surge forms of hazards that can be found on data lines.

Figure 3. Kinds of surges on data lines

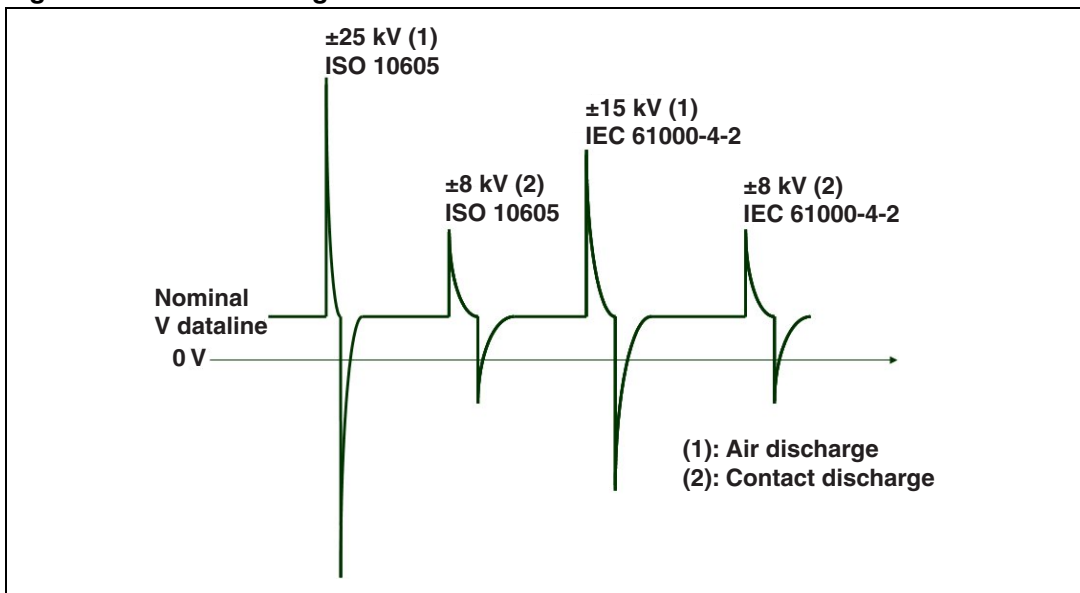

The ISO 10605 ESD surge test is applied to a complete system. This is simulating the ESD occurring on an electronic module in its environment due to human body contact.

1.2.2 Hazards on the supply rail

Transients that are generated on the supply rail range from severe low level-high energy, to high level-low energy with sometimes high dv/dt . These mainly concern ISO 7637-2 and ISO 10605 standards.

Figure 4 shows a simple representation of the form of major supply rail transients.

Figure 4. Kinds of surges on power rail

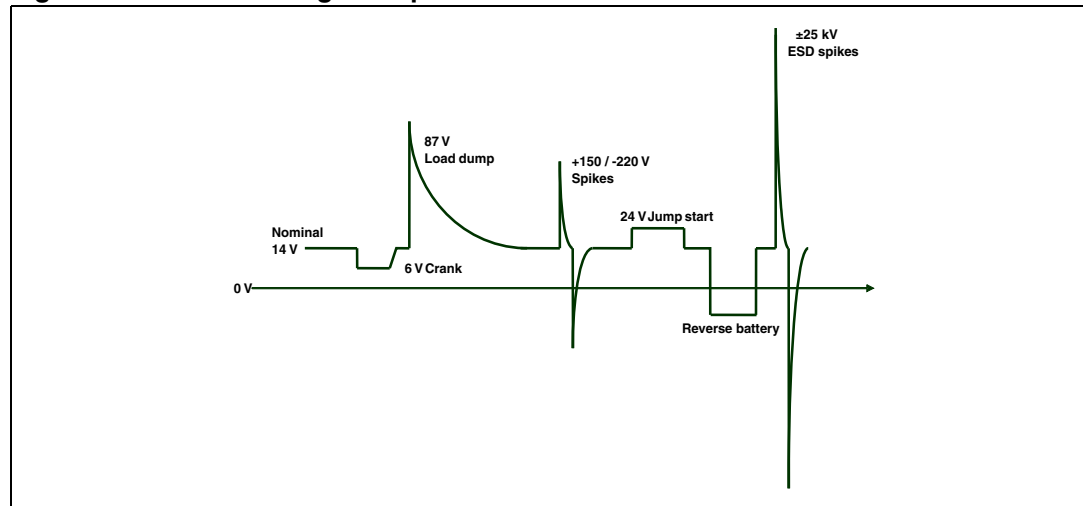

The most energetic transients are those resulting from load-dump and jump start. But all other hazards may affect the normal operation of electronic modules.

The “6 V crank” is caused by the starting of the car. The energy necessary to crank the engine makes the power voltage drop to 6 V.

The load-dump is caused by the discharged battery being disconnected from the alternator while the alternator is generating charging current. This transient can last 400 ms and the equivalent generator internal resistance is specified as 0.5 Ω minimum to 4 Ω maximum.

The “+150/-220 V Spikes” are due to the ignition system that is necessary to ignite the gasoline mixture. The frequency of the spikes depends on the engine rotation speed and the number of cylinders. These generate electromagnetic radiation.

The “24 V jump start” results from the temporary application of an over voltage in excess of the battery voltage. The circuit power supply may be subjected to a temporary over voltage condition due to the regulator failing or deliberately generated when it is necessary to boost start the car. In such condition some repair vehicles use 24 V battery jump to start the car. Automotive specifications call for the support of this over voltage application for up to 60 seconds.

The “reverse battery” is the result of battery inversion by mistake. Thus accessories have their power termination polarized in the wrong way.

The “25 kV ESD spike” is the result of electrostatic discharge (ESD)

All these events may affect the electronic environment as conducted hazards or as radiated hazards.

1.3 Standards for the protection of automotive electronics

All the hazards indicated above are described by several standards bodies such as the Society of Automobile Engineers (SAE), the Automotive Electronic Council (AEC) and the International Standard Organization (ISO).

Because the ISO 10605 ^(a) and the ISO 7637 ^(b) are the most important automotive standards regarding electrical hazards, this document mainly concerns the cases considering such standards.

-
- a. ISO 10605: standard for "Electrostatic discharges" due to human body discharging inside a vehicle applied to a complete system
 - b. ISO 7637 standard for "Electrical disturbances from conduction and coupling"

2 Parameters to consider in selecting protection devices

To make the best choice in protection device and considering [Figure 5](#), it is necessary to consider several parameters such as:

- Nominal voltage the electronic module runs with (V_{nom})
- Maximum voltage this electronic module can support (V_{max})
- Kind of surge that the electronic module may be called upon to support
 - If the surge shape is exponential:
 - What is the surge maximum voltage (V_s)?
 - What is the surge duration and at what level is it measured (t_p)?
 - What is the surge generator impedance (R_s)?
 - What is the number of cycles in the surge ($1/f$)?
 - If the surge is a DC surge:
 - What is the DC voltage level (V_{dc})?
 - What is the duration of the surge (t_p)?
 - What is the surge generator impedance (R_s)?
- What is the ambient temperature (T_{amb})?
- What kind of protection package is preferred?
- Is the electronic module a simple DC module or a digital one?
 - If digital:
 - What is the signal frequency (F)?
 - What are the rise and fall time of the surge signal (t_r , t_f)?
 - What is the maximum line capacitance (C_l)?

Figure 5. Surge application topology

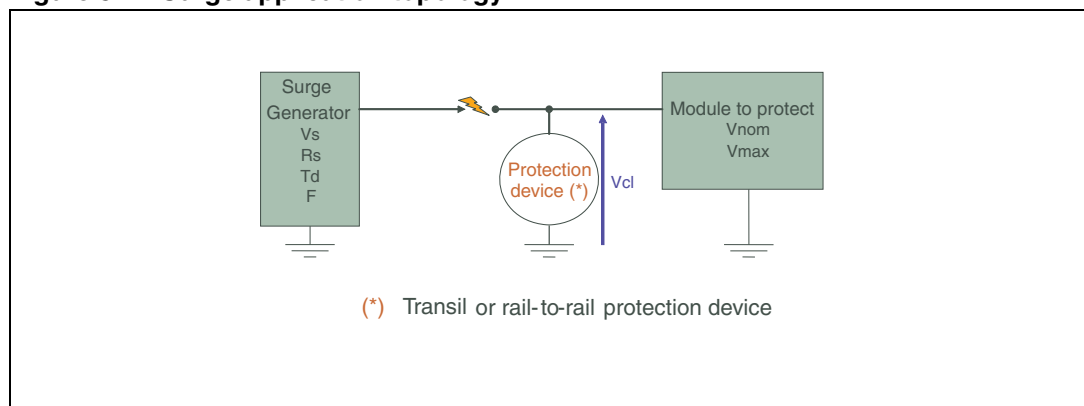

3 Data line protection

3.1 Protection topologies

3.1.1 Clamping topology

Various protection topologies can be chosen for data line protection. There is the usual topology that consists of using a clamping device as shown in [Figure 6](#). The action of the suppressor upon positive and negative surge occurrence is shown respectively in [Figure 7](#) and [Figure 8](#).

Figure 6. Data line protection using a Transil™

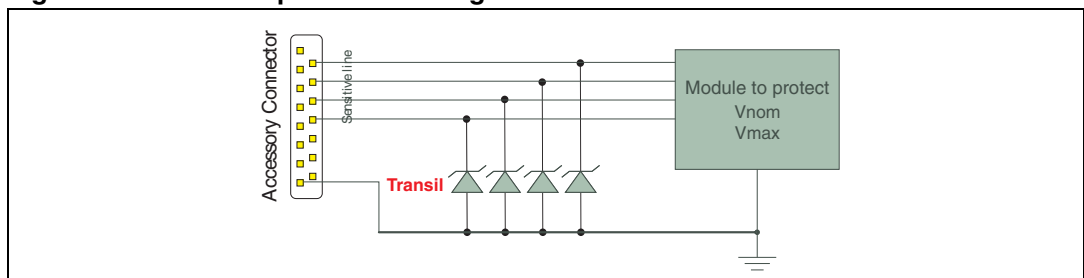

When a positive surge occurs, the over voltage is suppressed by the Transil as the voltage passes the breakdown voltage (V_{BR}). Thus the current is diverted to ground. The remaining voltage on the data line is limited to the clamping voltage (V_{cl}).

Figure 7. Positive surge suppression

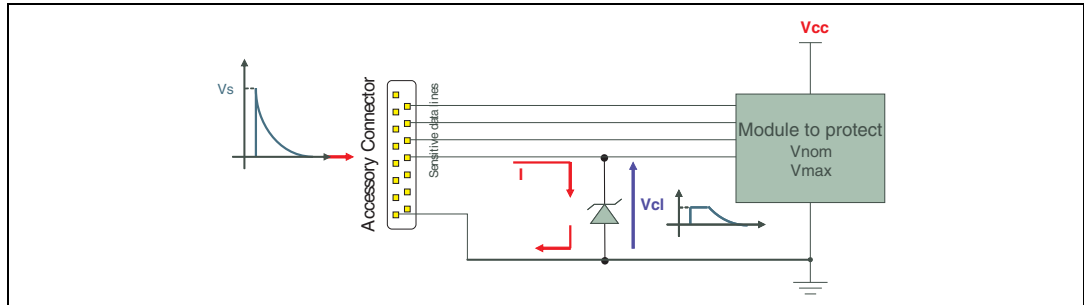

For the negative surge, the Transil is now in forward mode and the over voltage is eliminated as the surge voltage passes the forward voltage drop of the protection device (V_f). The remaining voltage is limited to the peak forward voltage of the Transil (V_{fp}).

Figure 8. Negative surge suppression

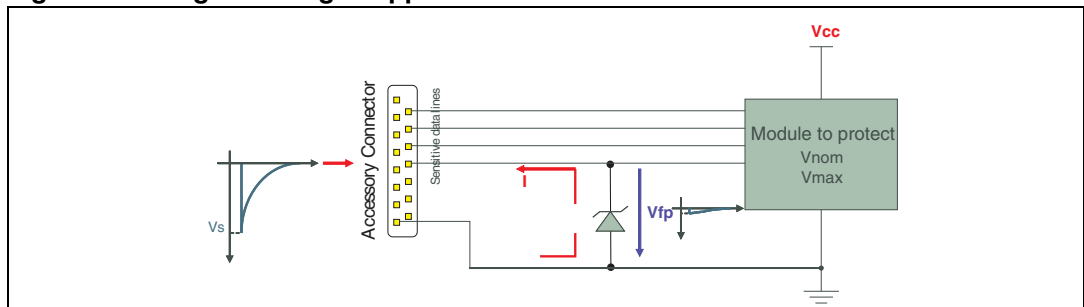

This topology is easy to manage. There should be as many protection devices as there are lines to protect. The protection device in fact can be several single Transils but there is a possibility to use protection devices in an array package so that one device protects each data line as shown in [Figure 9](#).

Figure 9. Data line protection using a diode array

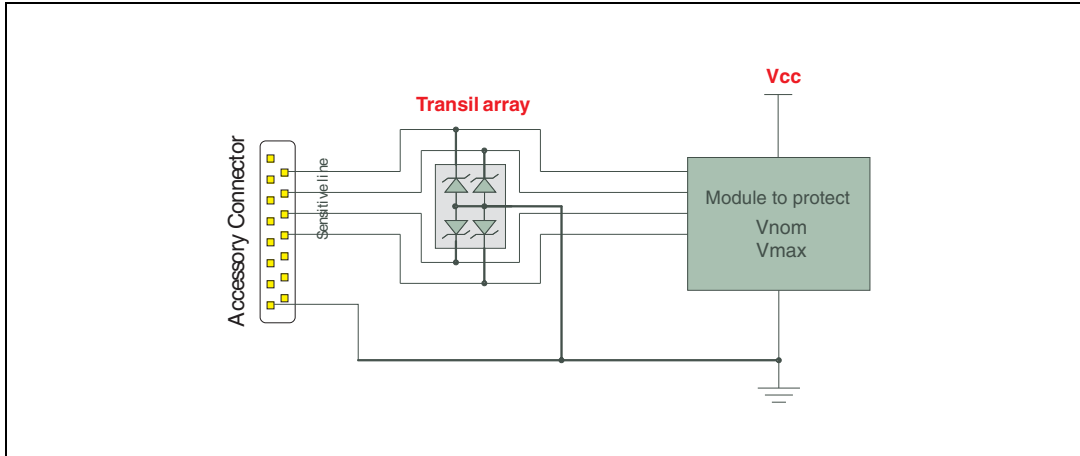

This clamping topology is good when the clamping voltage of each Transil is close to the nominal voltage of the data lines to be protected. For example, if the nominal voltage is 5 V, an ESDA6V1xx ($V_{br} = 6.1\text{ V}$) protection device is ideal. The Transil offers a fixed clamping voltage which does not require external power supply as in the rail-to-rail configuration but for some cases it is more convenient to use the rail-to-rail topology as described below.

3.1.2 Rail-to-rail topology

The rail-to-rail topology, shown in [Figure 10](#), is achieved using simple regular diodes. In that case the clamping level is no longer fixed but, instead, depends on the power supply voltage V_{CC} . As soon as a surge occurs, all the voltage over V_{CC} is diverted to the power supply as shown in [Figure 11](#).

In this case the remaining over voltage that the data line is exposed to is very low.

Figure 10. Rail-to-rail protection topology

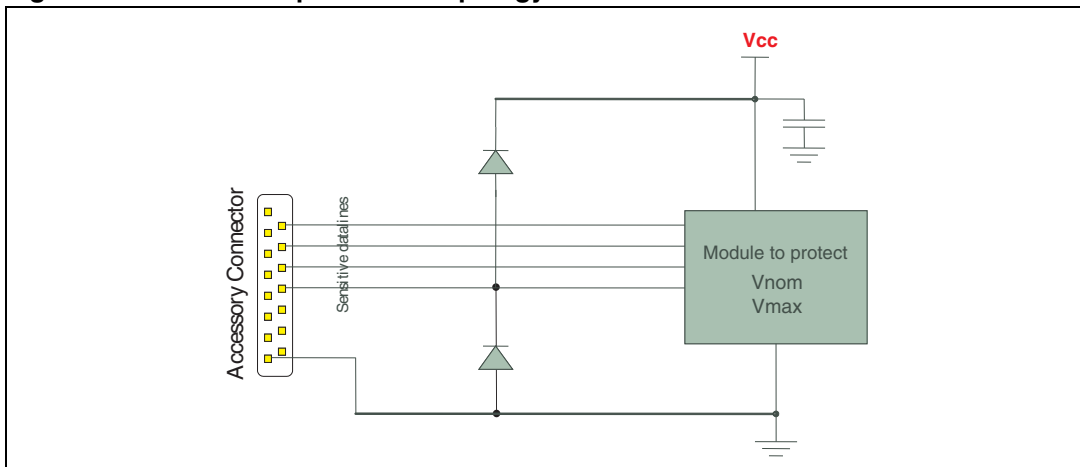

For a positive surge, shown in [Figure 11](#), as the over voltage reaches the power supply voltage V_{CC} plus the forward voltage drop of the upper diode, the surge current is diverted into the power supply line. To prevent this power supply line oscillating or being raised too much, a capacitor (47 nF suggested) is needed close to the rail-to-rail protection device.

The remaining voltage V at the module data line is limited to V_{CC} plus the forward voltage drop V_f of the upper diode.

Figure 11. Positive surge suppression

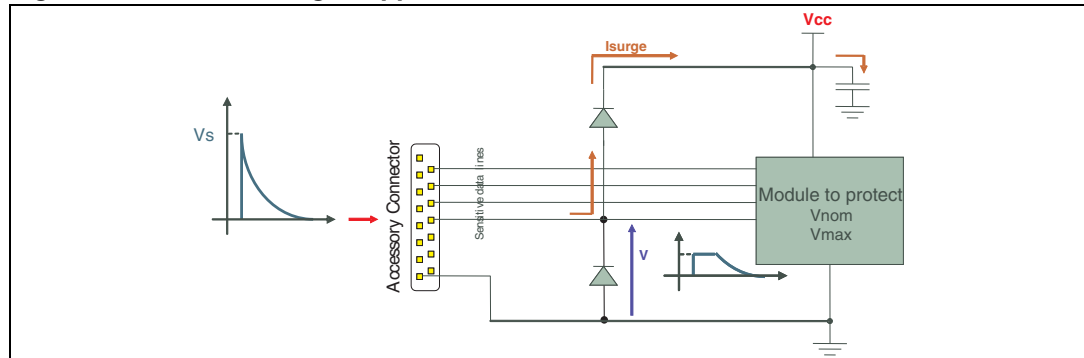

For the negative surge case ([Figure 12](#)), the surge suppression is the same as described in [Figure 8](#).

Figure 12. Negative surge suppression

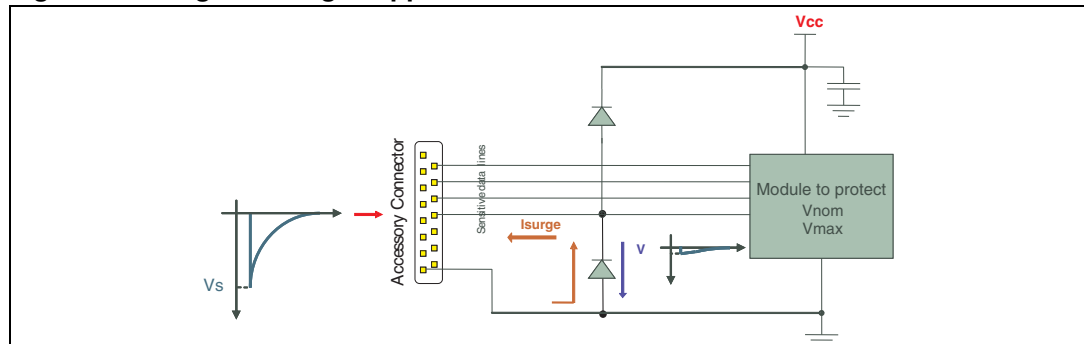

In the same approach as for the previous topology, there is a possibility to manage this rail-to-rail protection topology using as many single devices as there are data lines to protect or one diode array device that fulfills all line protection needs as shown in [Figure 13](#).

Figure 13. Rail-to-rail diode array

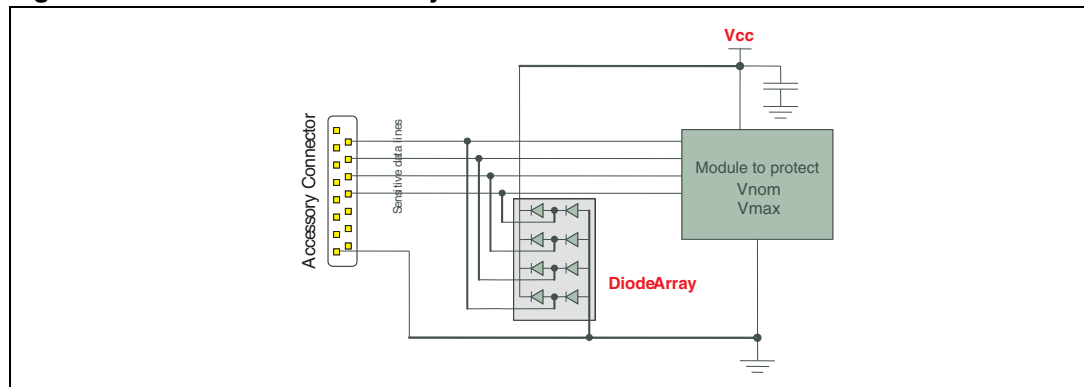

This solution requires that the V_{CC} voltage track be accessible and a decoupling capacitor is required close to the diode array device. On the other hand this topology is suitable for high speed data lines that often requires low parasitic line capacitance.

3.2 Data line protection example

Let's consider the ISO 10605 standard.

The ESD current waveform, shown in *Figure 14*, has the corresponding generator circuit given in *Figure 15* when the generator output is in short circuit.

This surge is specified for contact or air-discharge as shown in *Table 1* and maximum voltage occurring is a 25 KV (air-discharge)

Figure 14. ESD current waveform with generator output in short circuit

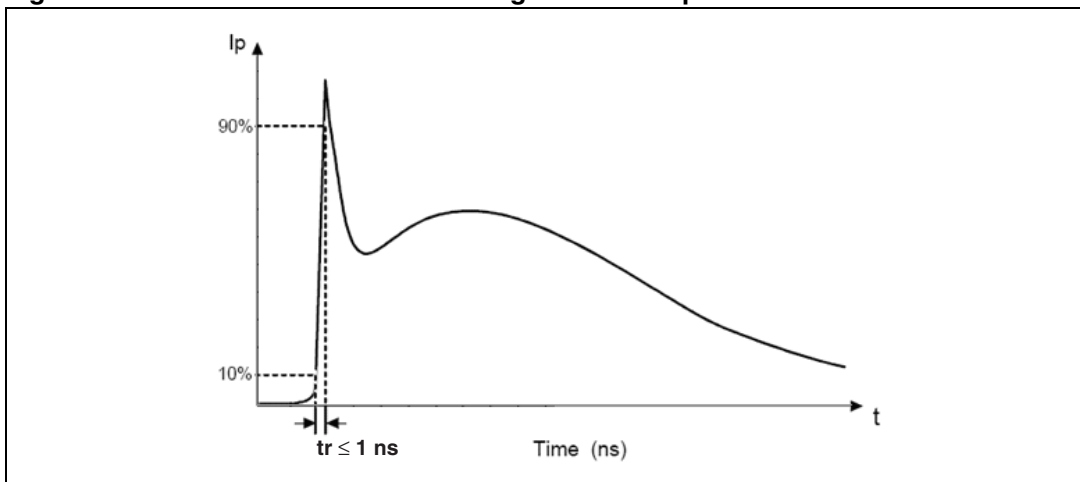
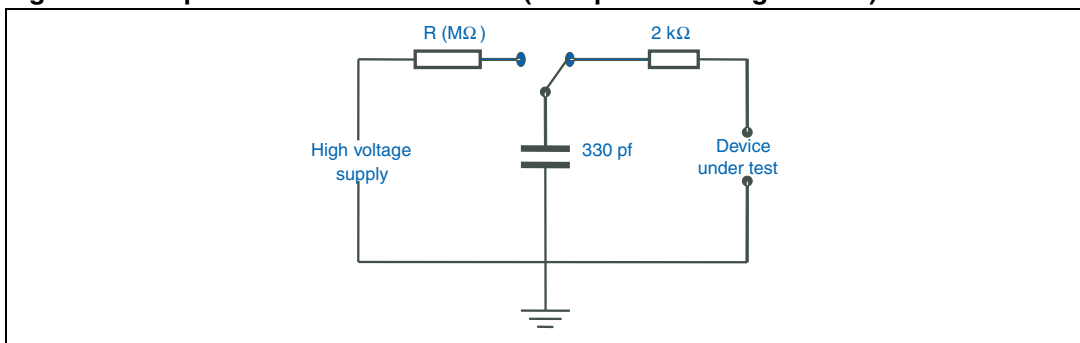

Table 1. Surge voltage levels for contact and air discharge

Contact discharge		Air discharge	
Level	Test voltage (kV)	Level	Test voltage (kV)
1	±4	1	±8
2	±6	2	±15
3	±8	3	±25

Figure 15. Equivalent circuit schematic (occupant discharge model)



If we consider the +25 kV air discharge surge test, then, regarding the suggested application given in [Figure 16](#): the worked example below may be used as a guideline for protection solution selection.

Figure 16. ISO 10605 ESD test set-up

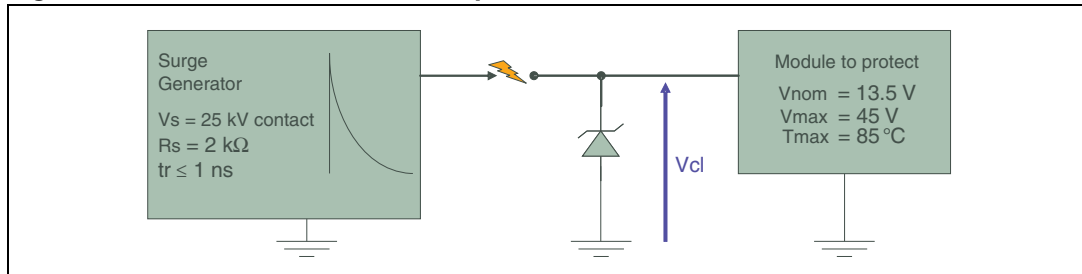

Identification of the best protection (Transil)

About the module to protect:

- The protection shall be “transparent” for the normal operating conditions of the module, in this case 13.5 V.
- The maximum voltage the module can withstand is 45 V so the Transil will not offer a higher voltage than 45 V when acting.
- The max temperature is 85 °C.

About the surge to suppress:

- The maximum voltage (V_{pp}) of the surge is 25 kV.
- The surge time constant duration τ is 660 ns ($R \cdot C$).
- The maximum repetition is one strike (t_1).
- The internal series resistor of the generator is 2 k Ω .

About the Transil:

- The suppressor has the following electrical characteristics ([Figure 17](#)):

Figure 17. Transil diode electrical characteristics

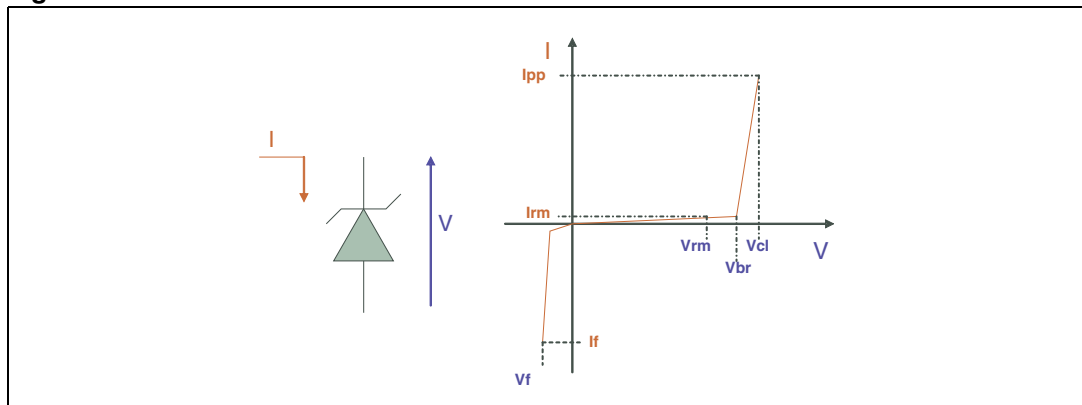

Where:

V_{rm} is the stand-off voltage measured @ I_{rm} . This corresponds to the nominal voltage of the application $V_{rm} \geq 13.5$ V.

V_{br} is the breakdown voltage measured @ 1 mA. This corresponds to the beginning of the action of the Transil.

V_{cl} is the clamping voltage $V_{cl} \leq 45$ V. Its value depends on the current that flows through the device. The relationship between this parameter and the current is given by:

$$V_{cl} = V_{br} + R_d * I_{pp}$$

Where:

- R_d is the dynamic resistance of the Transil.
- I_{pp} is the current imposed by the surge generator.
- I_{rm} is the leakage current measured @ V_{rm} .
- V_f is the direct voltage drop measured at current I_f depending on the application.

3.3 Design calculation example

Whatever the protection device package choice, the final choice will be directly linked to the power dissipation demanded by the surge.

Power is:

$$P_{pp} = V_{cl} * I_{pp}$$

with

$$V_{cl} = V_{br} + R_d * I_{pp}$$

The important missing parameter to solve these equations is the dynamic resistance R_d , which depends on the current value imposed by the surge.

3.3.1 Determination of R_d

R_d is the dynamic resistance of the Transil. It is dependent on the current surge rate and duration.

R_d is calculated by:

$$R_d = \frac{V_{cl} - V_{br_{max}}}{I_{pp}}$$

Where V_{cl} is the dynamic clamping voltage measured at I_{pp} for exponential surge duration.

For example, considering an SM6T27AY device ([Figure 18](#)), we can determine the R_d for a pulse duration $t_p = 1$ ms thanks to the 10/1000 μ s parameters of [Table 2](#):

Figure 18. SM6T27AY package

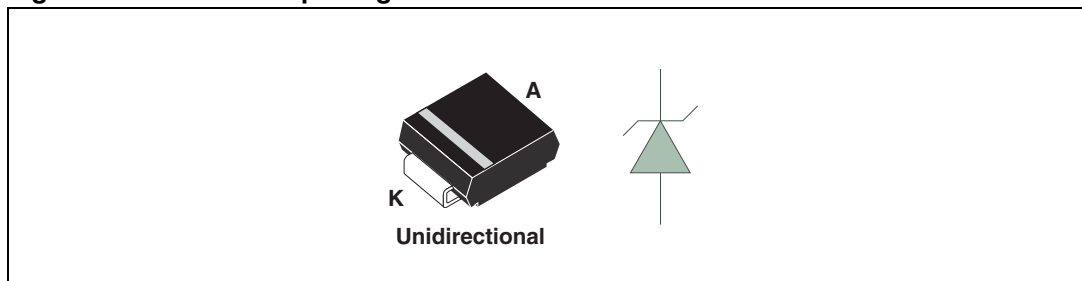

Table 2. SM6T27AY electrical characteristics, parameter values ($T_{amb} = 25\text{ }^{\circ}\text{C}$)

Order code	$I_{RM} @ V_{RM}$			$V_{BR} @ I_R^{(1)}$				$V_{CL} @ I_{PP}$ 10/1000 μs		$V_{CL} @ I_{PP}$ 8/20 μs		$\alpha T^{(2)}$	C
	max			min.	typ.	max	max		max		max	typ.	
	μA ($T_j=25^{\circ}\text{C}$)	μA ($T_j=85^{\circ}\text{C}$)	V	V	V	V	mA	V	A	V	A	$10^{-4}/^{\circ}\text{C}$	pF
SM6T27AY	0.5	1	23.1	25.7	27	28.4	1	37.5	16	48.3	83	9.6	1150

1. Pulse test: $t_p < 50\text{ ms}$.

2. $\Delta V_{BR} = \alpha T * (T_{amb} - 25) * V_{BR}(25\text{ }^{\circ}\text{C})$.

$$R_{d_{10/1000\mu\text{s}}} = \frac{37.5 - 28.4}{16} = 0.57\ \Omega$$

In the same way we can determine R_d for $t_p = 20\ \mu\text{s}$ pulse duration. In this case we should refer to the 8/20 μs parameters of [Table 2](#).

$$R_{d_{8/20\mu\text{s}}} = \frac{48.3 - 28.4}{83} = 0.24\ \Omega$$

For other t_p pulse durations the next procedure should be considered:

For $t_p < 20\ \mu\text{s}$, R_d is approximately equivalent to $R_{d_{20\mu\text{s}}}$ so we consider the 8/20 μs parameters of [Table 2](#).

For $20\ \mu\text{s} < t_p < 1\text{ ms}$, R_{dtp} is given by (t_p in μs):

$$R_{dtp} = \frac{R_{d_{1\text{ms}}} - R_{d_{20\mu\text{s}}}}{980} (t_p - 20) + R_{d_{20\mu\text{s}}}$$

For $t_p > 1\text{ ms}$, R_{dtp} is given by the following (t_p is the pulse duration in s in this case):

$$R_{dtp} = \alpha T R_{thj-a} \left(1 - e^{-\frac{t_p}{\tau}} \right)^B V_{br_{nom}}^2$$

αT is the temperature coefficient of V_{br} given in the Transil datasheet (see [Table 2](#)).

R_{thj-a} is the thermal impedance of the device at the junction-ambient area.

τ , and B define the transient thermal impedance. These parameters depend on the package as shown in [Table 3](#).

Table 3. Transient thermal impedance versus packages⁽¹⁾

Package	B	τ (s)	R_{thj-a} ($^{\circ}\text{C/W}$)
SMA	0.55	24	140
SMB	0.60	40	125
SMC	0.55	40	90
D ² PAK	0.63	120	60

1. SMA and SMB footprint = 50 mm^2 ($2 \times 25\text{ mm}^2$), SMC footprint = 128 mm^2 ($2 \times 64\text{ mm}^2$), D²PAK footprint = minimum footprint

During an ESD strike, the voltage diagrams look like those given in [Figure 19](#).

Figure 19. Voltage diagrams during an ESD strike

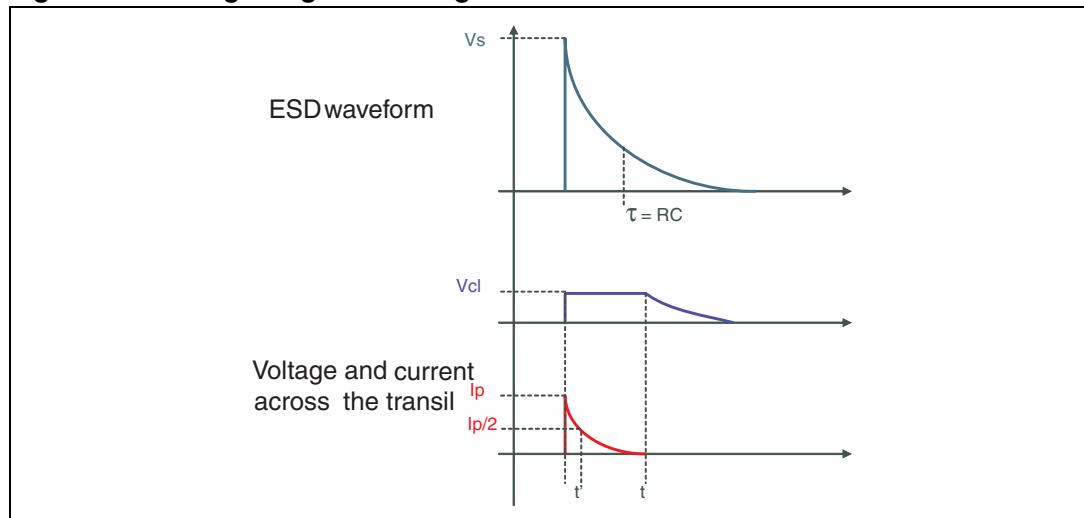

3.3.2 Power dissipation determination

To make sure the power of the surge will not damage the Transil we need to determine the power dissipated in the Transil.

Dissipated power is given by:

$$V_{cl} = V_{br} + R_d \cdot I_{pp}$$

$$I_{pp} = \frac{V_s - V_{cl}}{R_s}$$

and

$$P_{pp} = V_{cl} \cdot I_{pp}$$

In this study, the transient duration is much lower than 20 μs, therefore we consider R_d equivalent to $R_{d20\mu s}$.

This $R_{d20\mu s}$ can be easily calculated thanks to the Transil datasheets (see example given in [Section 3.3.1: Determination of \$R_d\$](#) for SM6T27AY)

So

$$R_{d20\mu s} = \frac{V_{cl20\mu s} - V_{br_{max}}}{I_{pp20\mu s}}$$

$$R_{d20\mu s} = 0.24 \Omega$$

Then the power dissipation can be determined from:

$$V_{cl} = V_{br_{max}} + R_{d20\mu s} \cdot I_{pp}$$

$$I_{pp} = \frac{V_s - V_{br_{max}}}{R_s + R_{d20\mu s}}$$

$$V_{br_{max}} \approx V_{br_{min}} + 10\%$$

Considering the ISO 10605 surge with $V_{pp} = +25 \text{ kV}$, $R_s = 2000 \ \Omega$ and $V_{brmax} = 28.4 \text{ V}$, the calculation produces:

$$V_{cl} = \frac{R_s V_{br_{max}} + R_{d_{20\mu s}} V_s}{R_s + R_{d_{20\mu s}}}$$

$$I_{pp} = \frac{V_s - V_{br_{max}}}{R_s + R_{d_{20\mu s}}}$$

Then $V_{cl} = 31.4 \text{ V}$ and $I_{pp} = 12.5 \text{ A}$

Therefore the maximum residual voltage that will be applied to the module is lower than the maximum voltage admissible (<45 V).

The question now is to determine if the Transil is able to withstand the power of the surge.

The peak pulse power (P_{pp}) dissipated in the Transil is:

$$P_{pp} = V_{cl} \cdot I_{pp} \Rightarrow P_{pp} = 392 \text{ W}$$

To see if this power can be supported by the Transil, it is necessary to determine the duration of the current that crosses the Transil during the surge compared to the peak pulse power versus exponential pulse duration graph shown in [Figure 20](#) (also in the datasheet).

Care must be taken at this step because the duration to be considered is the pulse duration at $I_p/2$. So it is necessary to determine the current surge duration (t' in [Figure 19](#)) that corresponds to half of the peak current crossing the Transil.

Figure 20. Peak pulse power versus exponential pulse duration

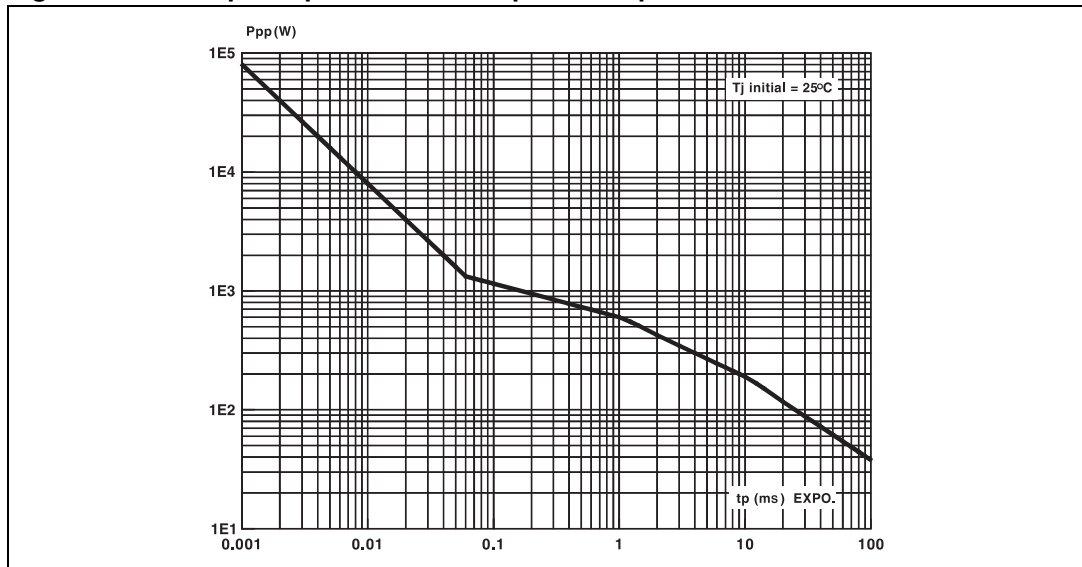
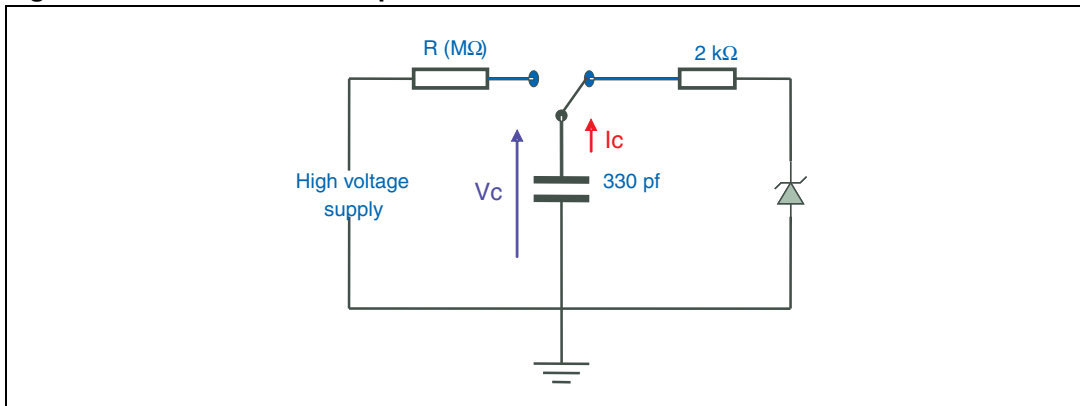

Figure 21. ESD ISO 10605 equivalent circuit



Considering the generator circuit shown in [Figure 21](#), which respects the ESD surge standard, the following equations apply:

$$I_c(t) = \frac{V_c(t) - V_{br}}{R_s + R_d}$$

And

$$I_c(t) = \frac{-C dV_c(t)}{dt}$$

Hence the equation

$$\frac{-C dV_c(t)}{dt} = \frac{V_c(t)}{R_s + R_d} - \frac{V_{br}}{R_s + R_d}$$

$V_c(t)$ can also be expressed as:

$$V_c(t) = \lambda \exp\left(\frac{-t}{C(R_s + R_d)}\right) + Y_0$$

where λ is a coefficient and Y_0 a constant. Thus:

$$\frac{dV_c(t)}{dt} = \lambda \frac{-1}{C(R_s + R_d)} \exp\left(\frac{-t}{C(R_s + R_d)}\right) + 0$$

For the initial conditions the limit of V_c when t tends to 0 is given by:

$$\frac{V_{c_0} - V_{br}}{R_s + R_d} = -C \left[\lambda \frac{-1}{C(R_s + R_d)} \exp\left(\frac{-t}{C(R_s + R_d)}\right) + 0 \right]$$

This reduces to

$$\frac{V_{c_0} - V_{br}}{R_s + R_d} = \frac{\lambda}{R_s + R_d}$$

Then

$$\lambda = (V_{c_0} - V_{br})$$

and thus

$$Y_0 = V_{c_0} - (V_{c_0} - V_{br}) \Rightarrow Y_0 = V_{br}$$

To determine the current, it is necessary to evaluate the voltage equation which is:

$$V_c(t) = (V_{c_0} - V_{br}) \exp\left(\frac{-t}{C(R_s + R_d)}\right) + V_{br}$$

It becomes then

$$I_c(t) = -C(V_{c_0} - V_{br}) \frac{-1}{C(R_s + R_d)} \exp^{\frac{-t}{C(R_s + R_d)}}$$

then

$$I_c(t) = \frac{V_{c_0} - V_{br}}{R_s + R_d} \exp^{\frac{-t}{C(R_s + R_d)}}$$

So to determine the time duration (t') at half value of the max current crossing the Transil, use the equation:

$$\frac{1}{2} \frac{V_{c_0} - V_{br}}{R_s + R_d} = \frac{V_{c_0} - V_{br}}{R_s + R_d} \exp^{\frac{-t'}{C(R_s + R_d)}}$$

which reduces to

$$t' = C(R_s + R_d) \ln 2$$

This produces a duration of $t' = 457 \text{ ns}$.

If now we use this value in the peak pulse power versus exponential pulse duration graph in [Figure 20](#), we can see that the SM6T27AY Transil is able to withstand more than 100 kW power dissipation for a 457 ns pulse duration (extrapolation of [Figure 20](#)). As the application can be submitted to an ambient temperature of +85 °C maximum, it is necessary to apply a derating factor to this value. [Figure 22](#) from the datasheet indicates the derating factor we must apply.

Figure 22. Peak power dissipation versus initial junction temperature

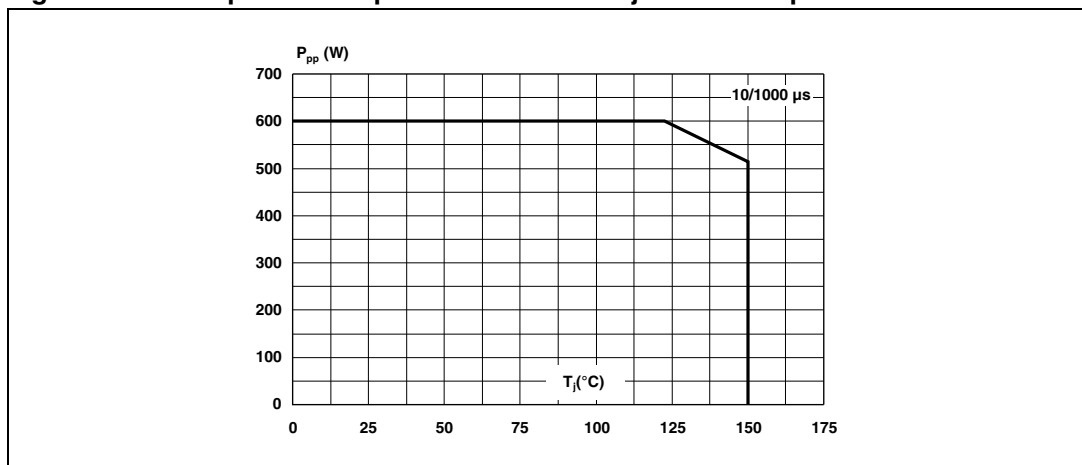

[Figure 22](#) shows that the derating factor is about 75% of the maximum power admissible. Then the device will be able to withstand more than 75 kW for a 457 ns surge duration as described in this example.

So compared to the application example where $P_{pp} = 392 \text{ W}$, the SM6T27AY device is more than suitable for the application

The SM6T27AY is too powerful with regards to the ISO 10605 test. Then, consider the use of a less powerful device such as the ESDA25LY shown in [Figure 23](#).

Figure 23. Package and internal circuit of the ESDA25LY

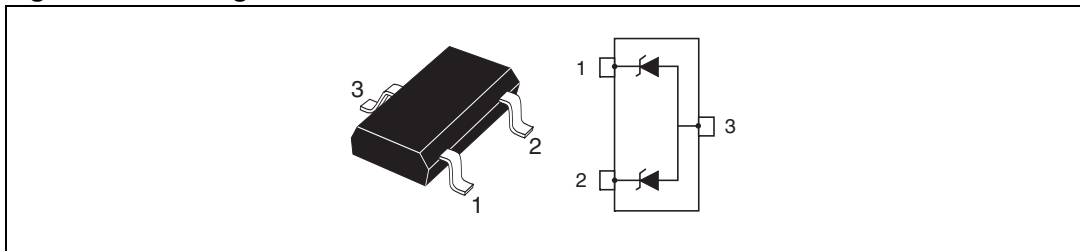

This device has the following characteristics:

Table 4. ESDA25LY electrical characteristics

Order code	V _{BR} @ I _R			I _{RM} @ V _{RM}		V _F @ I _F		R _d	αT	C
	min.	max.		max.		max.		typ. ⁽¹⁾	max. ⁽²⁾	typ. 0 V bias
	V	V	mA	μA	V	V	mA	mΩ	10 ⁻⁴ /°C	pF
ESDA25LY	25	30	1	1	24	1.2	10	1000	10	50

1. Square pulse, I_{pp} = 15 A, t_p = 2.5 μs.
2. Δ VBR = αT * (T_{amb} - 25 °C) * VBR (25 °C)

Figure 24. Peak pulse power versus exponential time duration

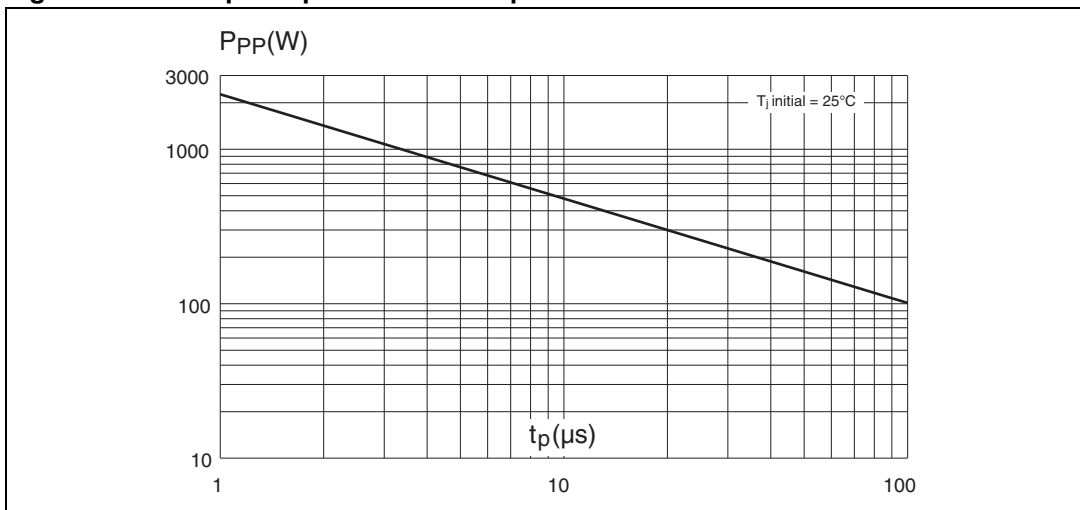

In the same way as for the SM6T27AY, the calculations give:

$$R_d = 1 \Omega, V_{cl} = 42.5 V, I_{pp} = 12.5 A$$

$$\text{then } P_{pp} = 531 W$$

and the t' current pulse duration is still 457 ns.

Figure 24 shows that for 457 ns pulse duration the maximum power the ESDA25LY can dissipate is higher than 2 kW. The ambient temperature derating makes a maximum power dissipation higher than 1.5 kW so the ESDA25LY device would be suitable in this protection application.

4 Supply rail protection

4.1 Protection topology

4.1.1 Clamping topology

For supply rail protection the recommended topology is the “clamping topology”.

[Figure 25](#) shows a schematic of the supply rail protection topology.

Figure 25. Supply rail protection using a Transil

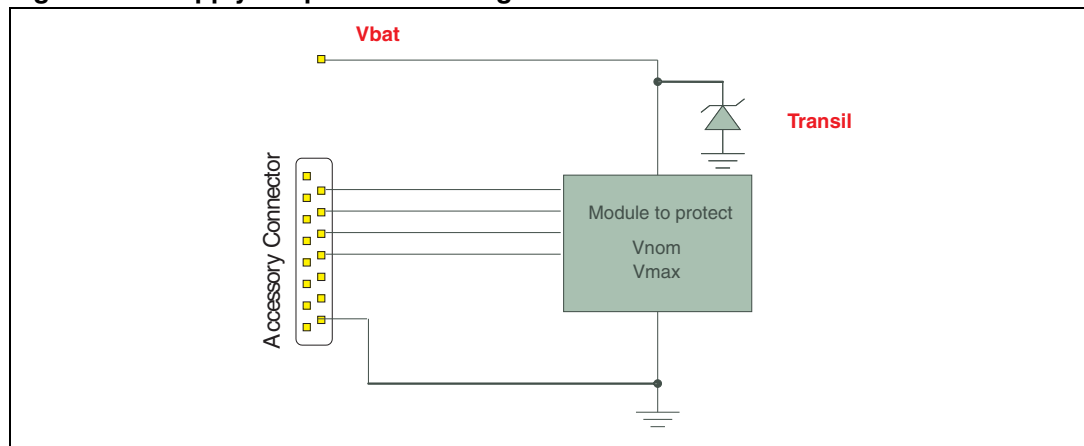

The choice of the protection device depends on the surge that is applied. To illustrate the possible device selection, two protection examples are given below.

4.2 Supply rail protection example 1: pulse 2 ISO 7637-2

Pulse 2 from ISO 7637-2 standard corresponds to a surge, which is produced by a sudden interruption of current in a device connected in parallel with the Transil, due to inductance in the wiring harness. The pulse is directly applied to the battery and is a positive pulse. See [Figure 26](#) for the pulse characteristics.

The typical parameters are:

- Rise time (10-90%) - approximately 10 μs (t_r)
- Pulse width (10-90%) - typically 50 μs (t_d)
- Pulse amplitudes from +37 V to +50 V (V_s)
- Pulse repetition from 0.2 Hz to 5 Hz (F)
- Output impedance 2 Ω

Figure 26. ISO 7637-2, pulse 2 waveform characteristics

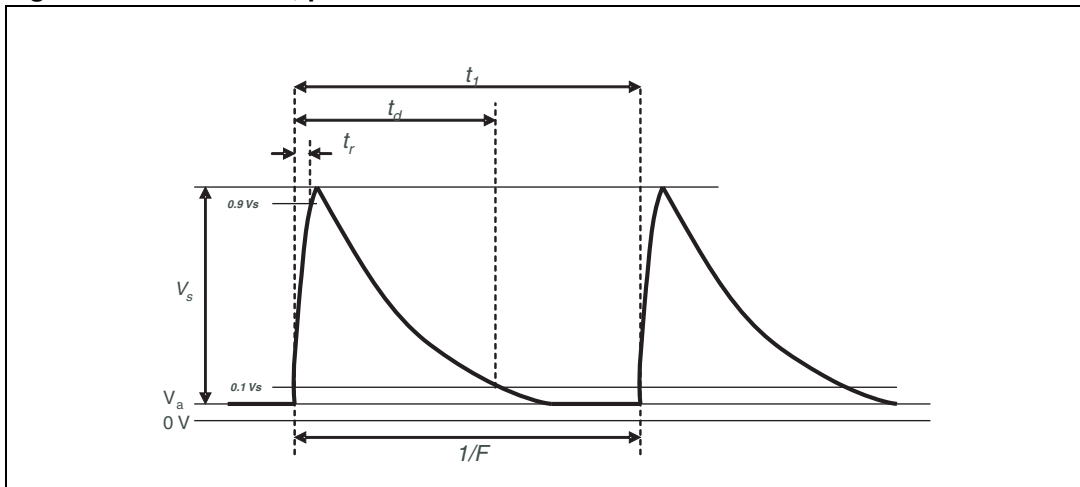
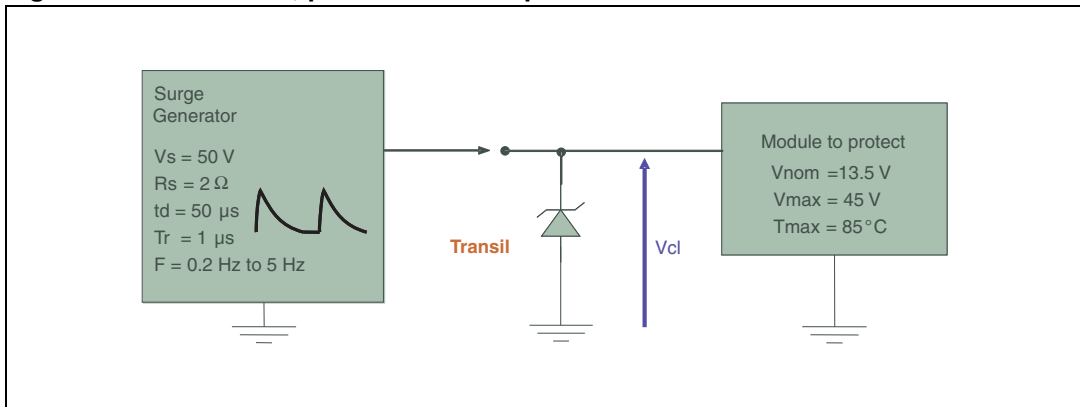

Figure 27. ISO 7637-2, pulse 2 test set up



As for the examples in [Section 3](#), it is necessary to check if the residual voltage after the protection device is safe for the electronic module and if the protection device itself can handle the power dissipated in the protection device during the suppression.

Let's consider an SM15T33AY protection device ([Figure 28](#)). Its specifications are given in [Table 5](#) and [Table 6](#).

Figure 28. SM15T33AY package

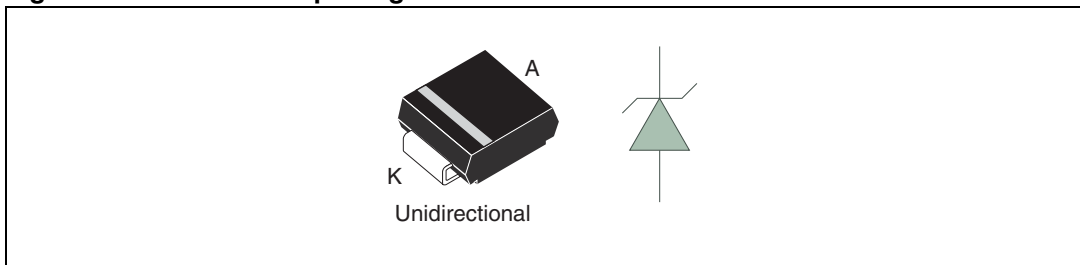

Table 5. SM15T33AY electrical characteristics (extract from datasheet)

Order code	I _{RM} @ V _{RM} max		V _{BR} @ I _R ⁽¹⁾				V _{CL} @ I _{PP} 10/1000 μs		V _{CL} @ I _{PP} 8/20 μs		αT max ⁽²⁾	C typ ⁽³⁾
			min.	typ.	max		max		max			
	μA	V	V	V	V	mA	V	A	V	A	10 ⁻⁴ /°C	pF
SM15T33AY	1	28.2	31.4	33	34.7	1	45.7	33	59.0	169	9.8	2700

1. Pulse test: t_p < 50 ms.
2. ΔV_{BR} = αT * (T_{amb} - 25) * V_{BR} (25°C)
3. V_R = 0 V, F = 1 MHz.

Table 6. SM15T33AY thermal parameter (extract from datasheet)

Symbol	Parameter	Value	Unit
R _{th(j-a)}	Junction to ambient on printed circuit on recommended pad layout	75	°C/W

4.3 Calculations for example 1

4.3.1 Determination of R_d

The voltage and current across the Transil are:

$$V_{cl} = V_{br_{max}} + R_d * I_{pp}$$

$$I_{pp} = \frac{V_s - V_{br_{max}}}{R_s + R_d}$$

Because R_d is dependent on the surge current duration and because its value for ISO 7637-2 pulse 2 is not given in the datasheet, it is necessary to determine it to solve the equations. But this time the generator internal schematic is not provided and none of the internal elements are known. So the easiest way to determine the current duration is to refer to the generator characteristics that are given in [Figure 29](#) and [Figure 30](#). These curves were produced from a SCHAFFNER NSG5500, MT5510 module. The voltage curve is for open circuit and the current curve produced when terminations were short circuited.

Figure 29. MT5510 output voltage in open circuit

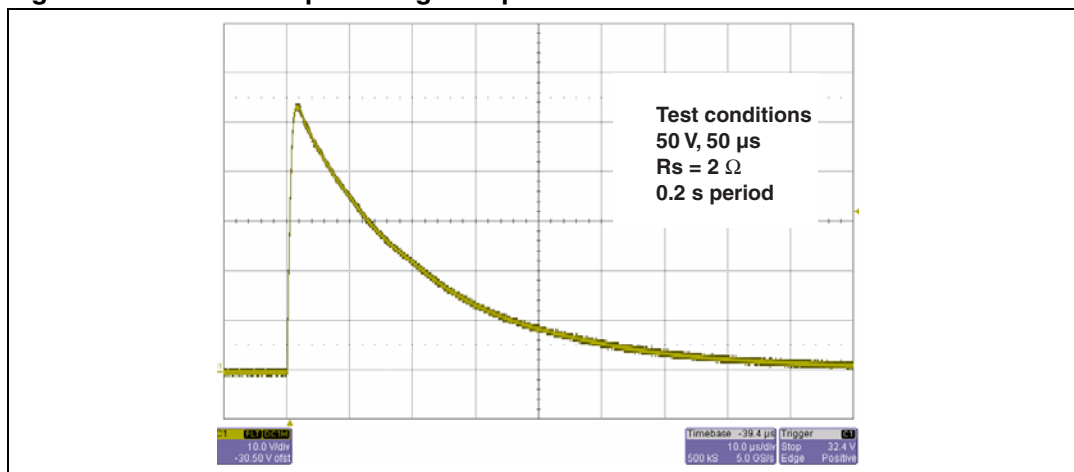
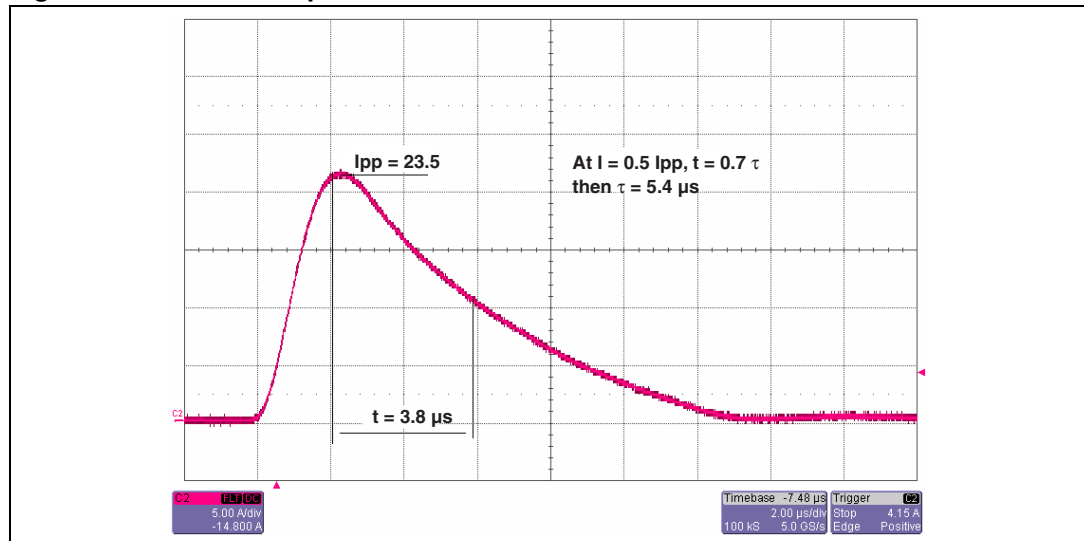

Figure 30. MT5510 output current in short circuit



In [Figure 30](#) the current waveform shape corresponds to the pulse 2 of the ISO 7637-2 standard delivered by the SCHAFFNER NSG5500 generator when terminations are short circuited.

As can be seen in [Figure 30](#), the time constant is 5.4 μs duration when the generator outputs are short circuited. When:

$$i = 0.5I_{pp} \rightarrow t = 0.7\tau$$

therefore

$$\tau = \frac{3.8}{0.7} \Rightarrow \tau = 5.4 \mu s$$

The current surge duration is below 20 μs. So, as explained previously when the duration is below 20 μs, consider the $R_{d<20\mu s}$ to be the same as $R_{d20\mu s}$

$$R_{d_{20\mu s}} = \frac{V_{cl_{20\mu s}} - V_{br_{nom}}}{I_{pp_{20\mu s}}}$$

$$R_{d_{20\mu s}} = 0.143 \Omega$$

From the equations in [Section 4.3 on page 23](#), $V_{CL} = 35.54 V$ and $I_{PP} = 7.22 A$, which means the residual over voltage will be consistent with the admissible maximum voltage of the module to protect.

4.3.2 Power dissipation determination

On the other hand the peak power dissipation in the Transil is:

$$P_{pp} = V_{cl} * I_{pp} \Rightarrow P_{pp} = 256 W$$

From the previous calculation in [Section 3.3.2 on page 19](#), the current duration at $I_p/2$ that will cross the Transil during the surge is given by the equation:

$$t' = C(R_s + R_d) \ln 2$$

and the time constant is

$$\tau = R_s C$$

where R_s is the serial resistor of the generator. In this case $R_s = 2 \Omega$

So the surge generator capacitor is $C = 2.7 \mu\text{F}$. Therefore, when considering the use of an SM15T33AY, the current duration at $I_p/2$ is:

$$t_{p_{SM15T33A}} = 2.7 * 10^{-6} (2 + 0.14) \ln 2$$

$$t_{p_{SM15T33A}} = 4 \mu\text{s}$$

(t_p is the current duration through the SM15T33AY measured between I_p and $I_p/2$)

It is now possible to compare this current duration with the curve given in [Figure 31](#).

For a current duration of $4 \mu\text{s}$, the peak pulse power the SM15T33AY can dissipate is approximately 20 kW.

Figure 31. Peak pulse power versus exponential pulse duration

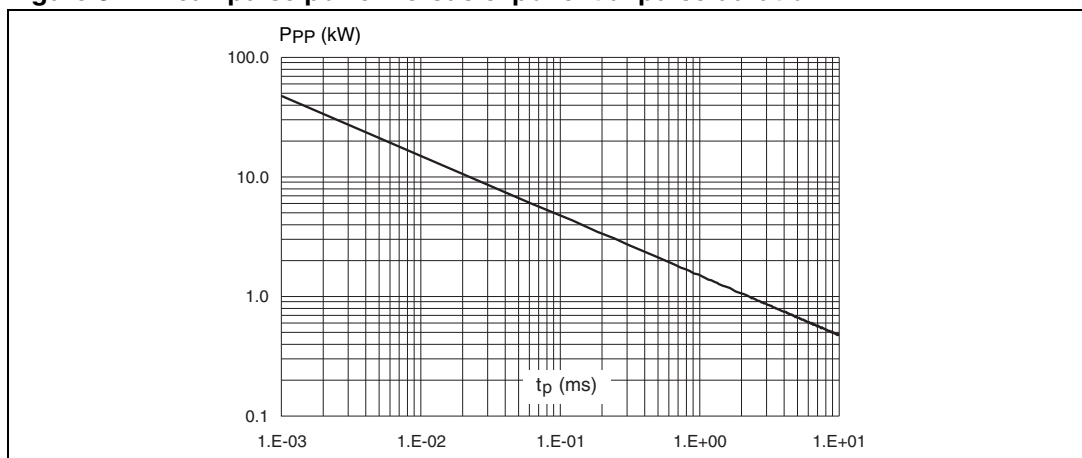

In the same way as for the previous examples, a derating factor needs to be considered regarding the ambient temperature. For $85 \text{ }^\circ\text{C}$ ambient temperature the derating is close to 70% (see [Figure 32](#)). So the maximum peak power the SM15T33AY can withstand for a $4 \mu\text{s}$ is instead 14 kW.

Figure 32. Peak power dissipation versus initial junction temperature

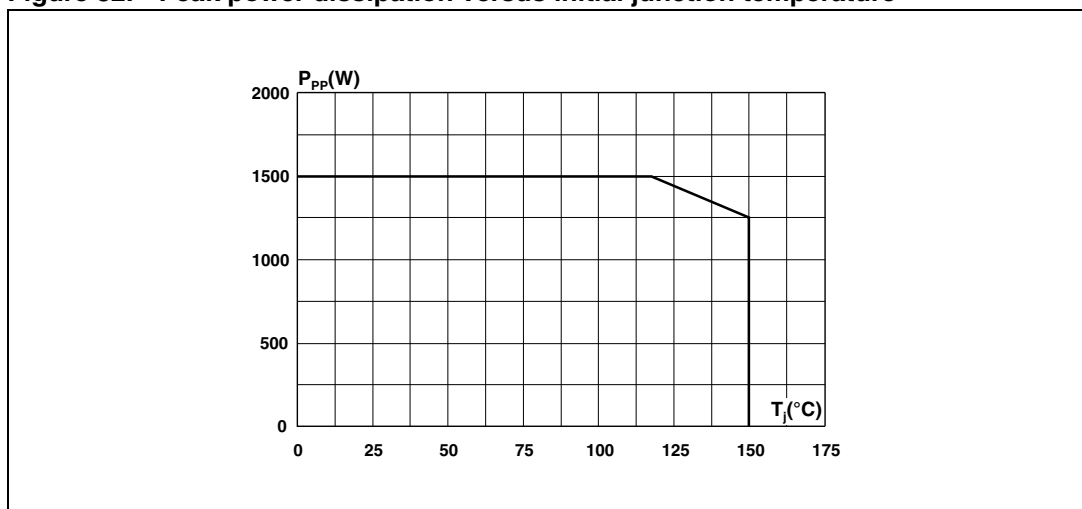

4.3.3 Junction temperature determination

Another point to consider is the surge repetition. This would make the SM15T33AY junction temperature rise. It is necessary to make sure this junction temperature rise will not pass the maximum specified. As per the SM15T datasheet, T_{jmax} is specified as 150 °C (absolute maximum ratings).

To clarify the situation, consider *Figure 33* where current, voltage and junction temperature rise are shown:

Figure 33. Voltage, current, and junction temperature behavior with surge repetition

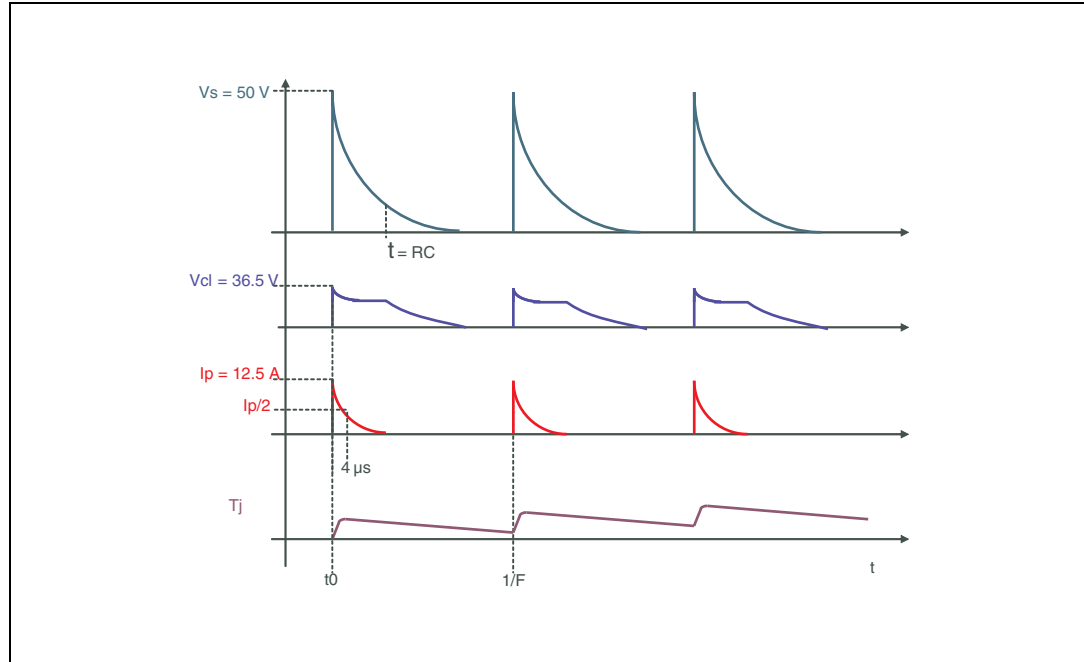

For repeated surges it is necessary to determine the average power (P_{av}) that the SM15T33AY will have to dissipate.

There is a relationship between the exponential surge duration curve and square shape surge duration. *Figure 34* illustrates the relationship between these types of surge.

Figure 34. Relationship between exponential pulse and square pulse duration

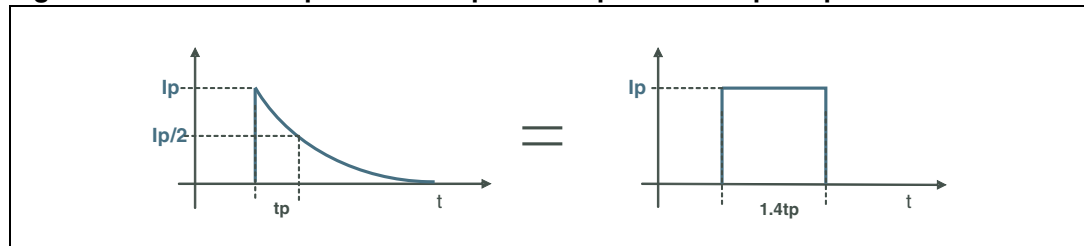

As shown on *Figure 34*, the current duration for equivalent square pulse duration is 1.4 times longer than the one measured at $I_p/2$ for an exponential surge. So we have the following equation:

$$I_{AV} = \frac{I_{pp} * 1.4t_{p/2}}{T} \Rightarrow I_{AV} = \frac{7.65 * 1.4 * 4 * 10^{-6}}{0.2} = 0.21\text{ mA}$$

Where t_p is the current duration at $I_p/2$ and T the minimum surge period.

Then the average power is:

$$P_{AV} = I_{AV} * V_{cl} \Rightarrow P_{AV} = 7.52 \text{ mW}$$

The junction temperature can be calculated as:

$$T_j = T_{amb} + P_{AV} R_{thj-a}$$

with $R_{thj-a} = 75 \text{ }^\circ\text{C/W}$.

The junction temperature will rise by less than $1 \text{ }^\circ\text{C}$ over the maximum ambient temperature. So the maximum junction temperature will not be exceeded. Therefore the SM15T33AY will be suitable for the application.

In the meantime, comparing the 274 W power induced by the surge with the SM15T33AY admissible power, the SM15T33AY is extremely safe regarding the ISO 7637-2 pulse 2 surge, even over-specified.

For this reason it would be more effective to choose a smaller Transil, like, for instance, an SM4T35AY ($V_{brmin} = 33.3 \text{ V}$). The same calculations show the power dissipation is quite similar to the SM15T33AY results. [Figure 35](#) and [Figure 36](#) show that the maximum power this SM4T35AY can dissipate for $4 \mu\text{s}$ exponential pulse duration is still higher than that the surge imposes. The SM4T35AY is able to withstand more than 3 kW for $4 \mu\text{s}$ surge duration.

Figure 35. Peak pulse power versus exponential time duration of an SM4T Transil

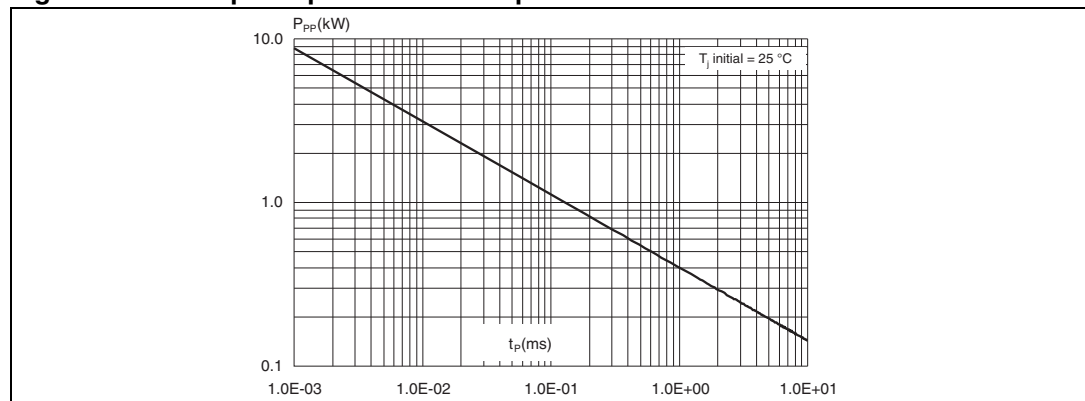
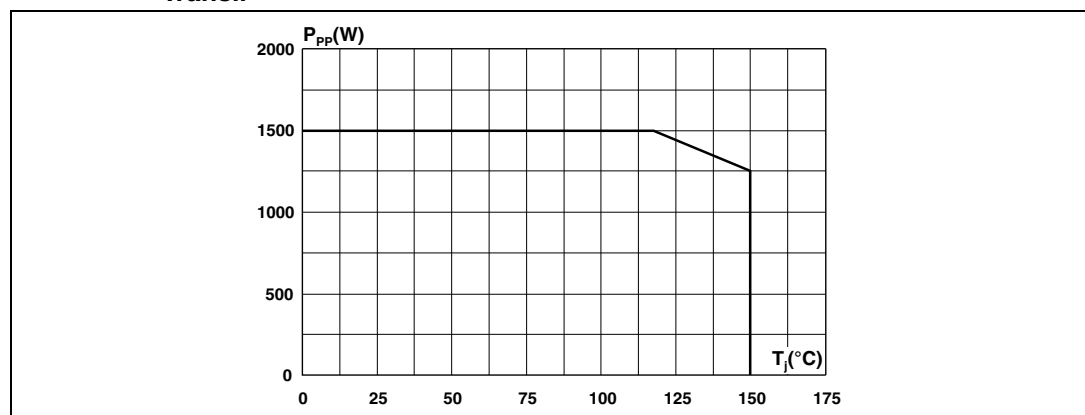

Figure 36. Peak power dissipation versus initial junction temperature of SM4T Transil



4.4 Supply rail protection example 2: pulse 5a load dump ISO 7637-2

The load dump is caused by the discharged battery being disconnected from the alternator while the alternator is generating charging current

Parameters are:

- Pulse width - t_d [40 to 400 ms]
- Pulse amplitude - V_s [65 to 87 V]
- Impedance is R_s [0.5 Ω to 4 Ω]
- $V_{bat} = 13.5$ V

Figure 37. ISO 7637-2, pulse 5a waveform characteristics

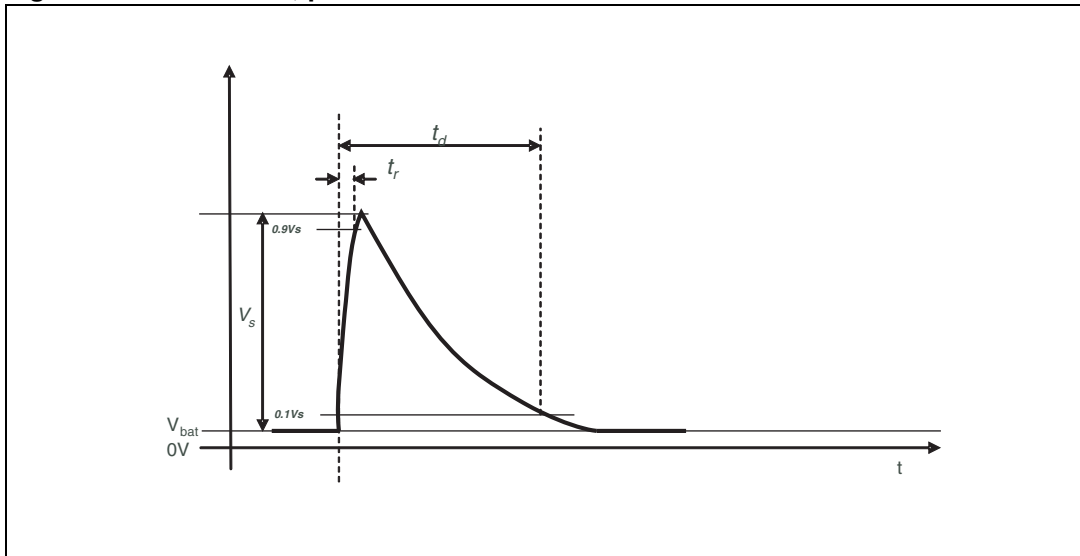
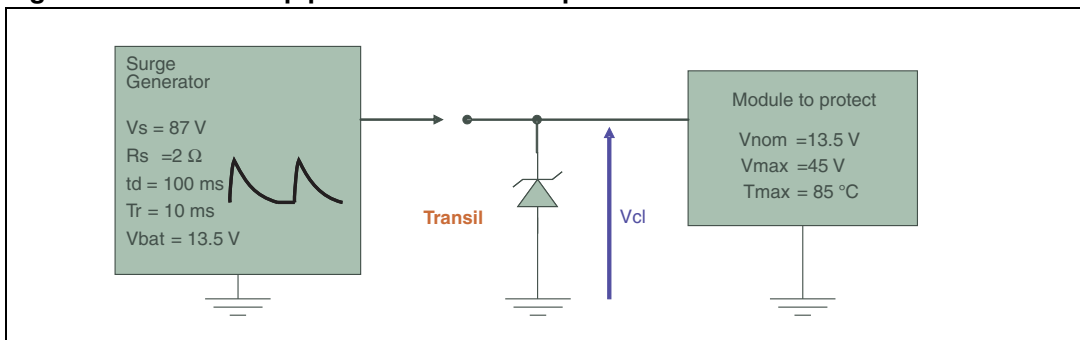
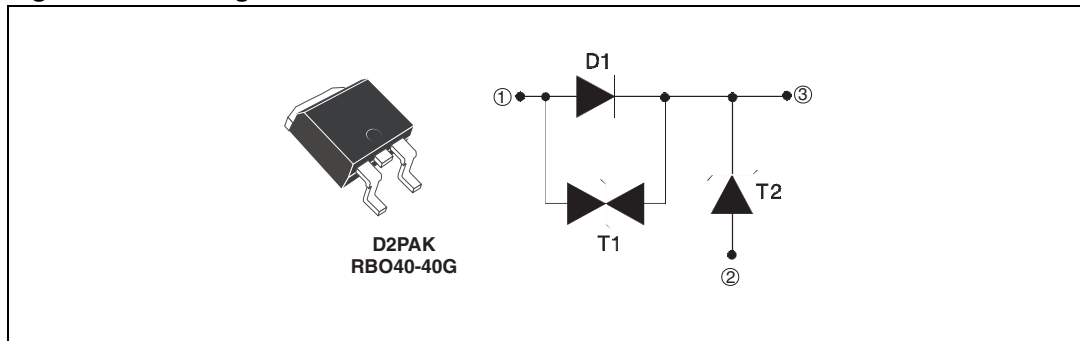

Figure 38. Load dump protection test set up



In the same manner as for the last case (ISO pulse 2), we have to determine if the residual voltage after the protection device is safe for the electronic module and if the power dissipation involved in the protection device during the suppression is supported by the protection device itself.

Consider now the RBO40-40 device (see [Figure 39](#)) which offers a surge protection capability and a reverse battery protection.

Figure 39. Package and internal schematic of the RBO40-40

Its specifications are the following:

Table 7. RBO40-40G electrical characteristics, Transil T2 (-40 °C < T_{amb} < +85 °C)

Symbol	Test conditions	Min.	Typ.	Max.	Unit
V _{BR 32}	I _R = 1 mA	22		35	V
V _{BR 32}	I _R = 1 mA, T _{amb} = 25°C	24	28	32	V
I _{RM 32}	V _{RM} = 20 V			100	μA
I _{RM 32}	V _{RM} = 20 V, T _{amb} = 25°C			10	μA
V _{CL 32}	I _{PP} = 20 A ⁽¹⁾ tp = 10/1000μs			40	V
αT	Temperature coefficient of V _{BR}			9	10 ⁻⁴ /°C
C ₃₂	F = 1MHz V _R = 0 V		8000		pF

1. One pulse

4.5 Calculations for example 2

The voltage and current across the Transil are:

$$V_{cl} = V_{br_{max}} + R_d \cdot I_{pp}$$

$$I_{pp} = \frac{V_s - V_{br}}{R_s + R_d}$$

As with the previous example, the internal elements of the surge generator are not known. So, the easiest way to proceed is to refer to the voltage and current curves of the generator.

With voltage and current curves produced from a SCHAFFNER NSG5500, LD5505 module, (see [Figure 40](#) and [Figure 41](#)), we can measure the duration t_p which corresponds to the duration between I_p and $I_p/2$

Figure 40. LD5505 output voltage in open circuit

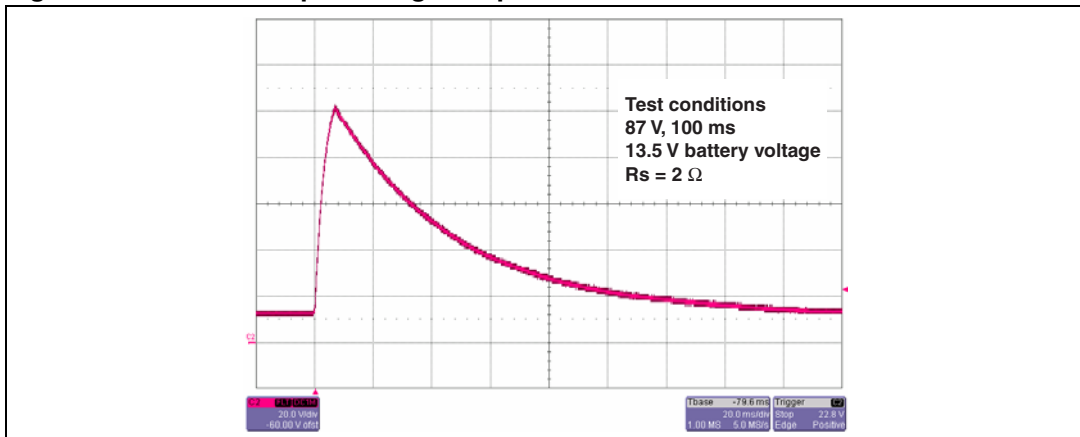

Figure 41. LD5505 output current in short circuit

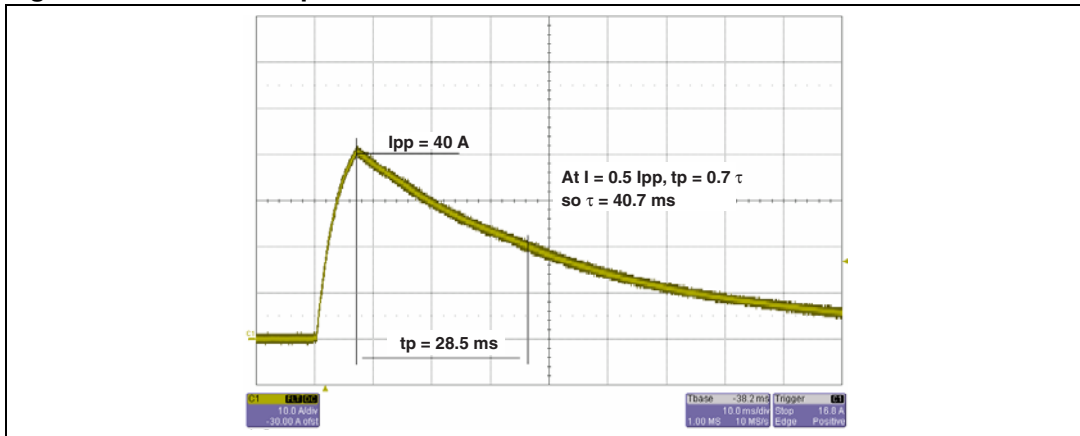

Figure 41 shows the current waveform corresponding to the pulse 5a of the ISO 7637-2 standard delivered by the SCHAFFNER NSG5500 generator when terminations are short circuited

The t_p duration measured between I_p and $I_p/2$ is 28.5 ms. Then the time constant calculated is 40.7 ms (generator outputs short circuited).

4.5.1 Determination of R_d

For $t_p > 1$ ms, R_{dtp} is given by:

$$R_{dtp} = \alpha TRth_{j-a} \left(1 - e^{-\frac{t_p}{\tau}} \right)^B V_{br_{nom}}^2$$

t_p is in seconds in this case.

τ , and B define the transient thermal impedance (see [Table 3: Transient thermal impedance versus packages](#)).

When the surge is applied to the RBO40-40 transient suppressor:

$$t_{p_{RBO40-40}} = C(R_s + R_{dtp}) \ln 2$$

And the time constant is $\tau = R_s C$.

So, $C = 20.35 \text{ mF}$.

Hence:

$$t_{p_{RBO40-40}} = 20.35 * 10^{-3} (2 + R_d) \ln 2$$

$$R_{d_{tp}} = 9 * 10^{-4} * 60 \left(1 - e^{-\frac{tp}{20}} \right)^{0.63} 28_{nom}^2$$

Then, thanks to the test curves from the load dump generator, the result is $t_p = 33.6 \text{ ms}$ and $R_d = 0.22 \Omega$.

From the equations in [Section 4.5 on page 29](#), $V_{cl} = 33.8 \text{ V}$ and $I_{pp} = 26.6 \text{ A}$, which means the residual over voltage will be consistent with the admissible maximum voltage of the module to protect.

4.5.2 Power dissipation determination

The peak power dissipation in the Transil will be:

$$P_{pp} = V_{cl} * I_{pp} \Rightarrow P_{pp} = 549.25 \text{ W}$$

[Figure 42](#), shows that for 33.6 ms exponential surge duration the maximum admissible power the RBO40-40 can withstand is approximately 900 W.

Figure 42. Peak pulse versus exponential surge duration

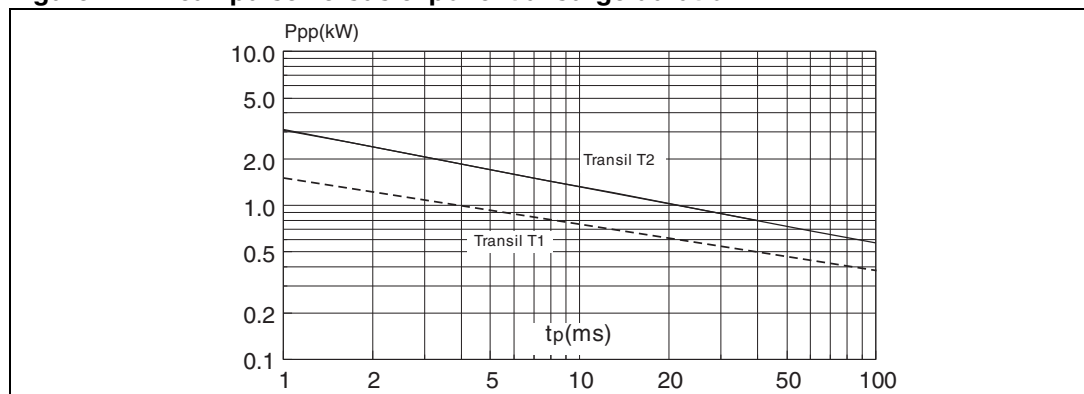

[Figure 43](#). shows the derating factor for the ambient temperature effect.

Figure 43. Relative variation of peak power versus junction temperature

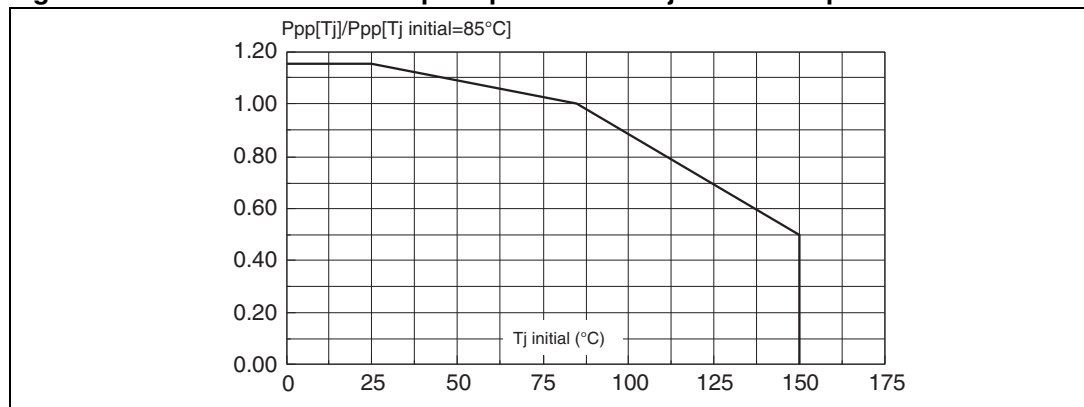

For +85 °C ambient temperature, the derating factor is 1. So the power dissipation induced by the load dump surge is supported by the RBO40-40 device.

The RBO40-40 combines a transient suppressor diode and also a reverse battery protection. This function is helpful in case of battery polarity inversion that can occur by mistake. A direct diode is placed in series with the power supply so that all power supply inversion is safe for the protection diode (see [Figure 43](#)).

The direct diode reverse battery protection can also be replaced with a simple fuse. However, upon battery inversion this fuse will blow and the module will need to be replaced or repaired.

Figure 44. Use of serial protection devices for reverse battery prevention

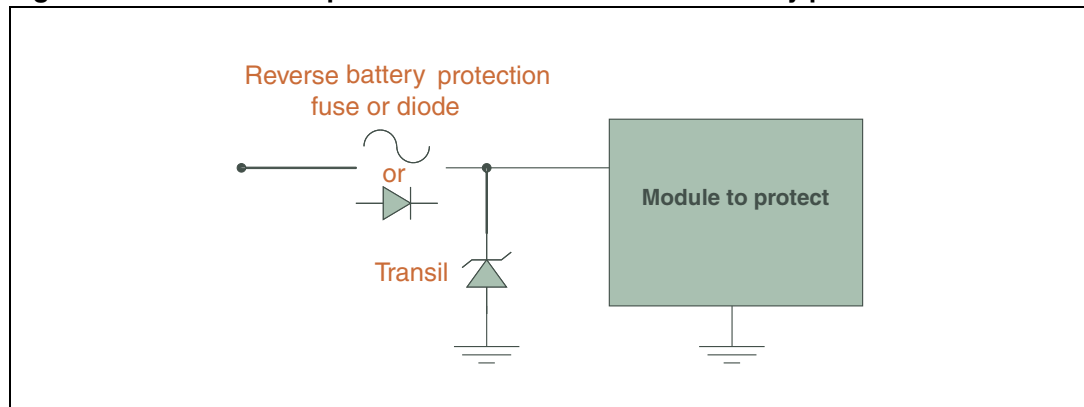

Besides the ISO pulse 2a the Transil has to eliminate, and the reverse battery protection, there is another condition to consider in the automotive environment. This condition is the starting aid.

The starting aid covers the possibility of starting 12 V vehicles with a 24 V truck battery in case of emergency. Then, the Transil nominal voltage will need to be higher than this starting aid voltage. That is the reason the Transil nominal breakdown voltage is 27 V minimum. In this case the Transil is not active during starting aid test. No dissipation occurs in the device so the Transil is safe.

5 PCB layout recommendations

Once the protection device has been selected, the designer has to pay attention to the device placement on the board. This is because the device placement has a big impact on protection efficiency and on parasitic electromagnetic coupling.

5.1 Parasitic inductances of the Transil and the PCB tracks

5.1.1 Parasitic inductance from Transil wiring

[Figure 45](#) provides an example of a protection schematic.

Figure 45. Protection circuit schematic using a Transil

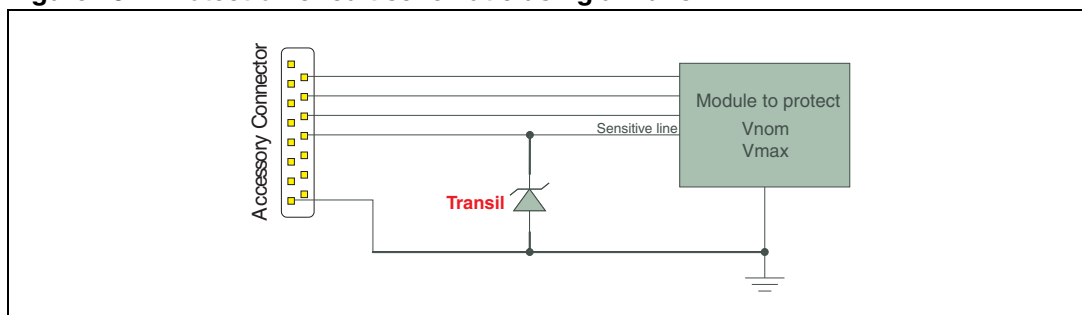

[Figure 46](#) shows what happens in the circuit when an over voltage occurs on the sensitive protected line. The over voltage surge is suppressed by the Transil. When the voltage reaches the breakdown voltage of the Transil, a current I crosses the protection device and a residual voltage V is applied at the module input line.

Figure 46. Current and voltage at the Transil termination when a surge is applied

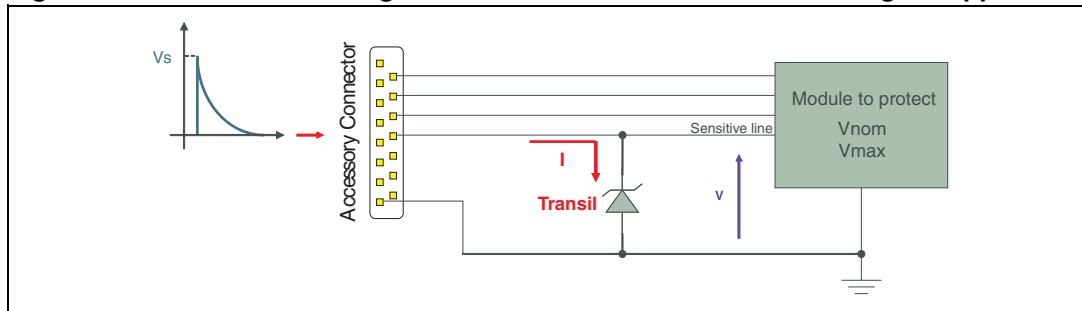

This is the simple representation of the Transil action but in fact things are more complicated and the more realistic circuit is given in [Figure 47](#).

Figure 47. Parasitic elements due to the wiring

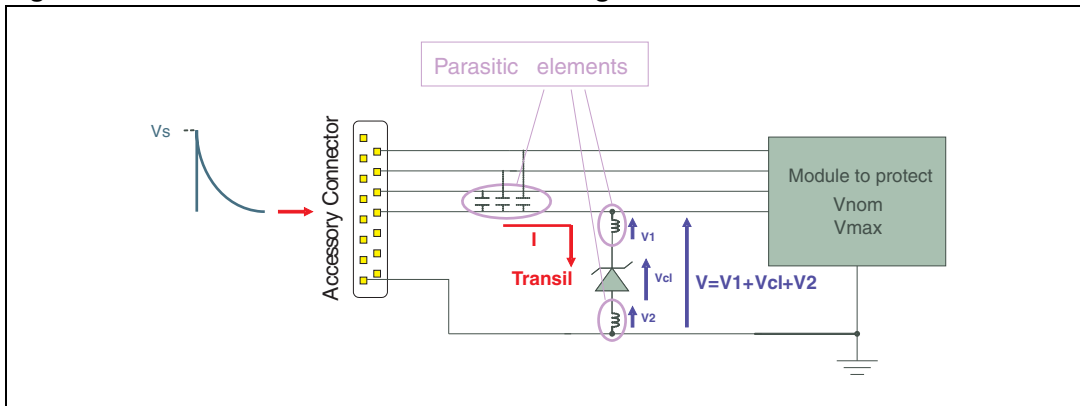

Figure 47 shows there are two major parasitic elements:

- Some parasitic inductance each side of the Transil
- Some parasitic capacitance between lines

There is also some parasitic inductance brought by the lines themselves. These parasitic elements cause inductive and capacitive coupling.

These parasitic couplings may induce over voltages or electromagnetic noise on adjacent lines which have nothing to do with the protected lines.

The parasitic inductance is directly due to the PCB routing. The wiring tracks to the protection device may drastically affect the efficiency of the protection device.

Consider a 35 μm copper track, 0.3 mm wide (W), spaced at 0.5 mm (h) from a ground plane (see Figure 48). This gives the ratio h/W of 1.7. Figure 49 (AEMC source) shows, for an h/W ratio of 1.7, a parasitic inductance of 5 nH/cm.

Figure 48. Double sided PCB structure - single track

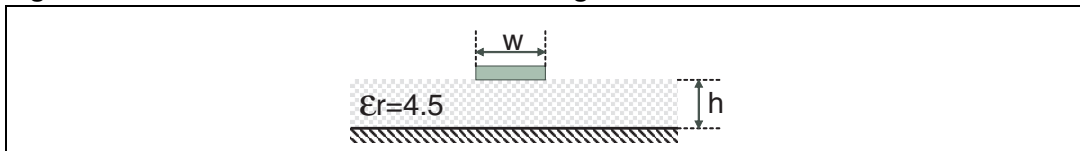
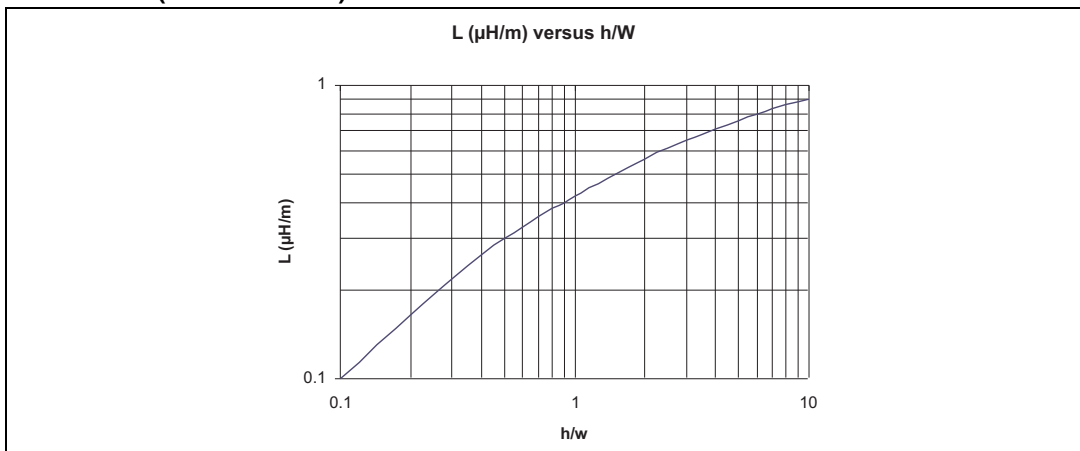

Figure 49. Inductance variation versus PCB thickness for single copper track (AEMC source)



Consider the PCB layout example in *Figure 50*. The lengths of track that connect the Transil to the sensitive line and the ground line are respectively 10 mm and 6 mm.

These lines show inductances of approximately 5 nH and 3 nH as shown in the schematic in *Figure 51*

Figure 50. PCB routing example

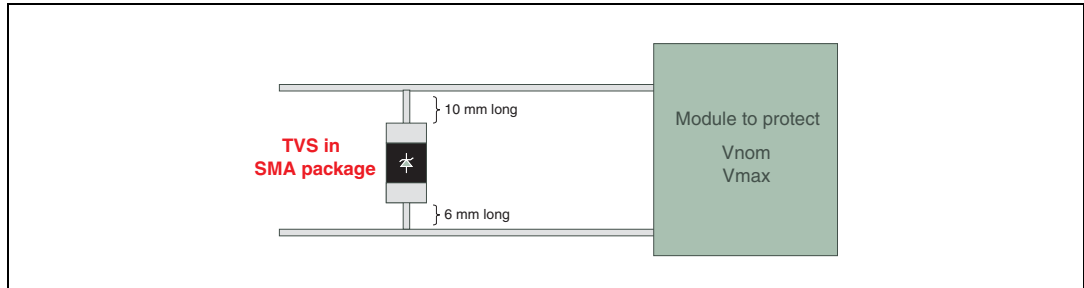
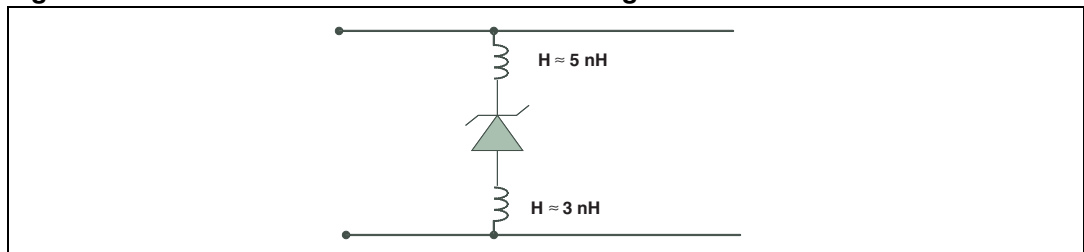
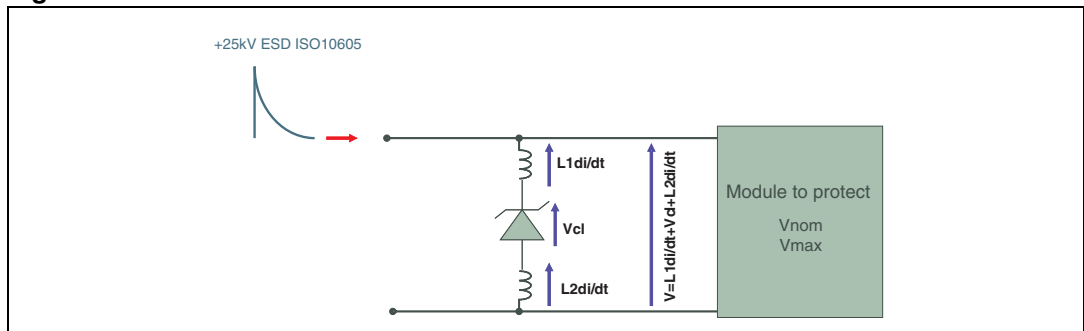

Figure 51. Parasitic inductance due to the wiring tracks



When a +25 kV ESD air discharge is applied (ISO 10605) the remaining voltage at the module to protect is split in three parts as shown in *Figure 52*.

Figure 52. Parasitic inductance effect on fast transient



The Transil offers a clamping voltage V_{cl} and an internal resistance “ R_d ”. Whereas the inductors bring on over voltage Ldi/dt .

To determine the Ldi/dt voltage

The ESD surge generator has an internal resistor of 2 kΩ. The max Voltage is +25 kV, the rise time of the surge is specified as $t_r \leq 1ns$

The current that would cross the Transil is:

$$I = \frac{25000 - V_{cl}}{2000} \approx \frac{25000}{2000} \approx 12.5 \text{ A}$$

Then

$$\frac{di}{dt} = \frac{12.5}{10^{-9}} \Rightarrow 12.5 \cdot 10^9 \text{ A} \cdot \text{s}^{-1}$$

Therefore, for L1, the over voltage is

$$L1 \frac{di}{dt} \approx 62.5 \text{ V}$$

and for L2 the over voltage is

$$L2 \frac{di}{dt} \approx 37.5 \text{ V}$$

That means the total over voltage seen by the module would be something close to $V_{cl} + 100 \text{ V}$! This shows that whatever the protection device, if the routing is not optimized there will be a big impact of the track inductance to the protection device on the remaining voltage in case of fast transient discharge. *Figure 53.* illustrates the recommended Transil wiring to prevent this phenomenon.

Figure 53. Recommended Transil wiring

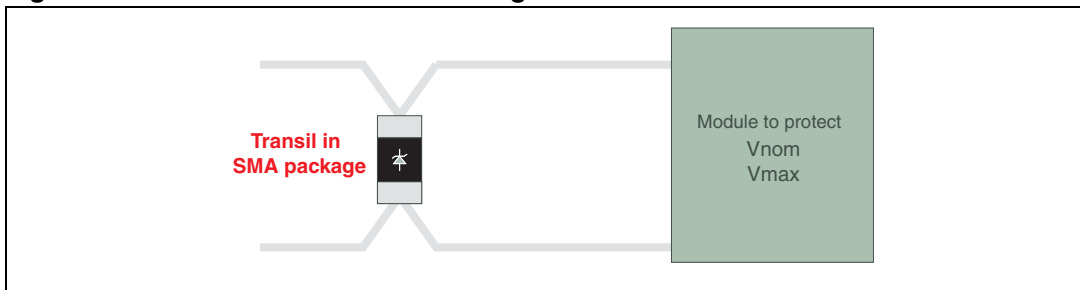

The equivalent schematic diagram for the recommended wiring layout is shown in *Figure 54.*

Figure 54. Details of the remaining voltage at the module to protect

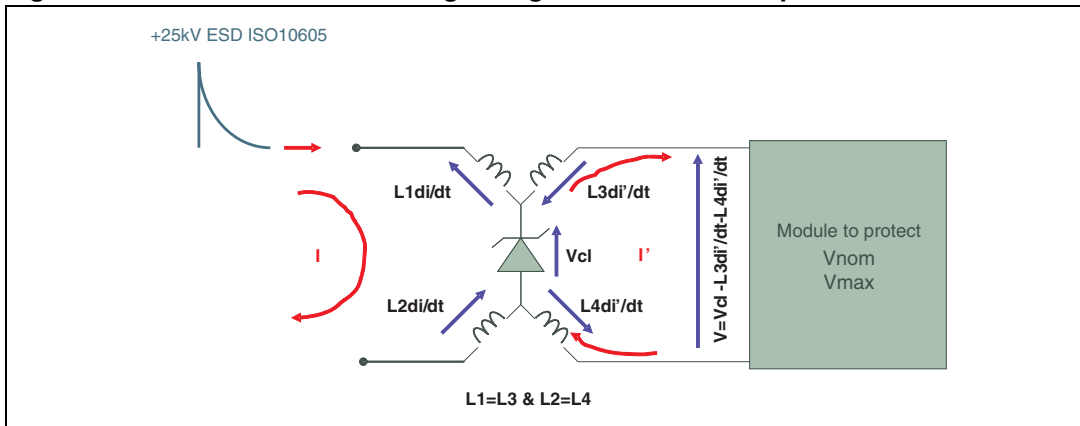

In this layout the remaining voltage at the module to protect is:

$$V = V_{cl} - L3 \frac{di'}{dt} - L4 \frac{di'}{dt}$$

So, in the worst case (when $L3 = L4 = 0$), V is equal to V_{CL} .

5.1.2 Capacitive and inductive coupling

The parasitic capacitance (see *Figure 47*) is due to the geometrical conception of the PCB and the routing together. *Figure 55* shows the effective capacitive coupling during surge suppression.

Figure 55. Capacitive coupling representation

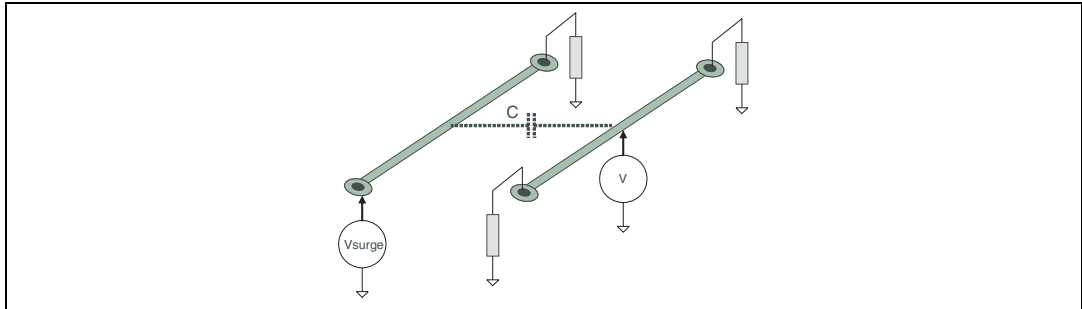

This parasitic capacitance depends on the PCB and track structures as shown in *Figure 56* and *Figure 57*. This parasitic capacitance is defined by the space between tracks, the track width and the PCB thickness as well.

Figure 56. Double side PCB structure in coplanar

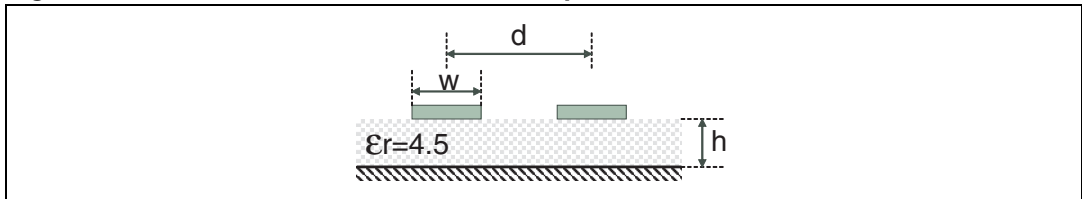
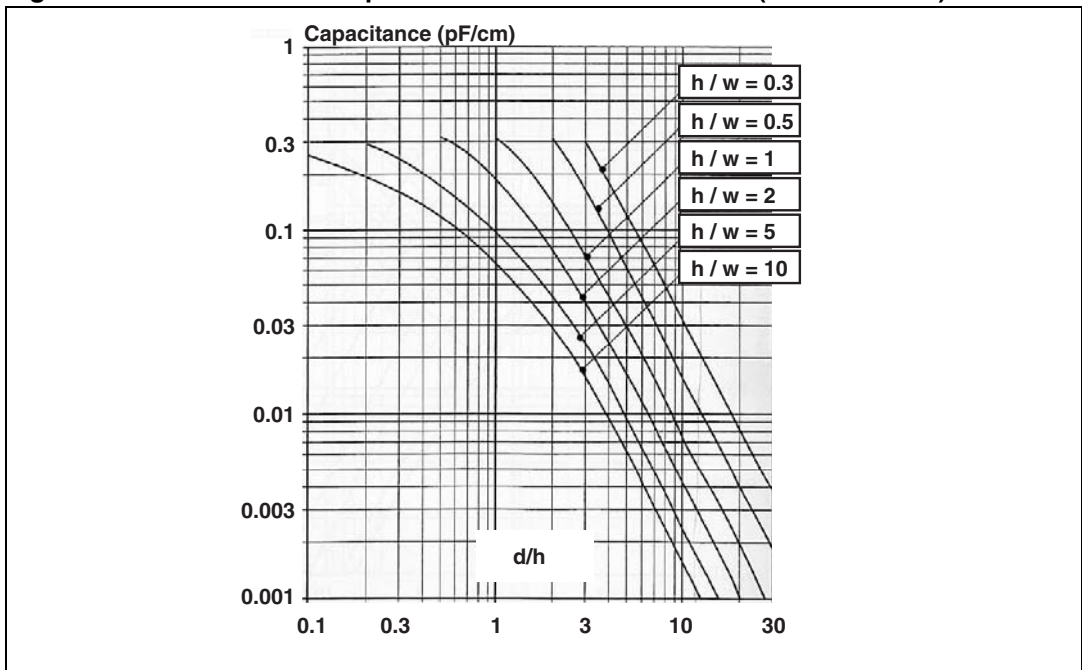

Figure 57. Track to track capacitance for double side PCB (source AEMC)



The longer is the line to the protection device, the higher will be the capacitive coupling.

Inductive coupling is also present on the PCB. This is sometime also called “inductive cross-talk”. When over voltage occurs, a current crosses the track and makes this track radiate. This coupling depends on the current variation rate (di/dt). The parasitic inductance coupling is shown in [Figure 58](#).

Figure 58. Inductive coupling representation

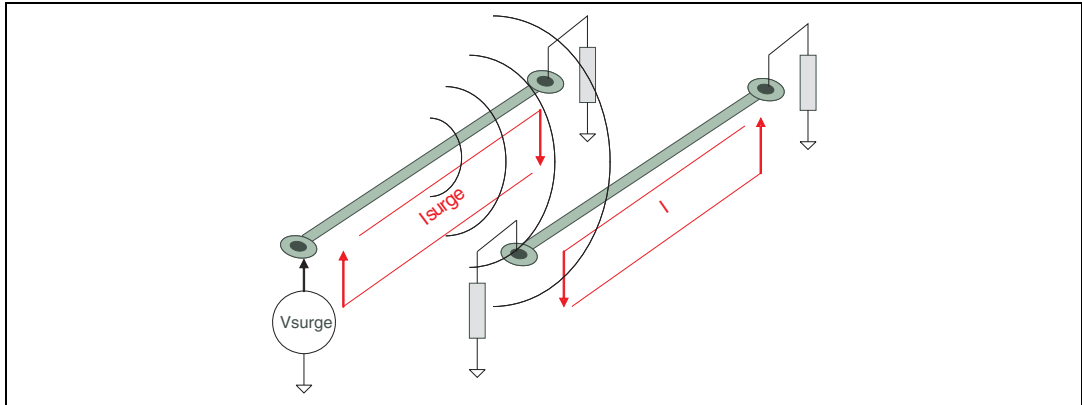

Like capacitive coupling, the longer the tracks to the protection device the larger will be the electromagnetic field.

The solution to minimize the capacitive and inductive coupling consists of placing the protection device as close as possible to the accessories connector, where the surge impact is the most probable. ([Figure 59](#))

Figure 59. Where to place the protection device

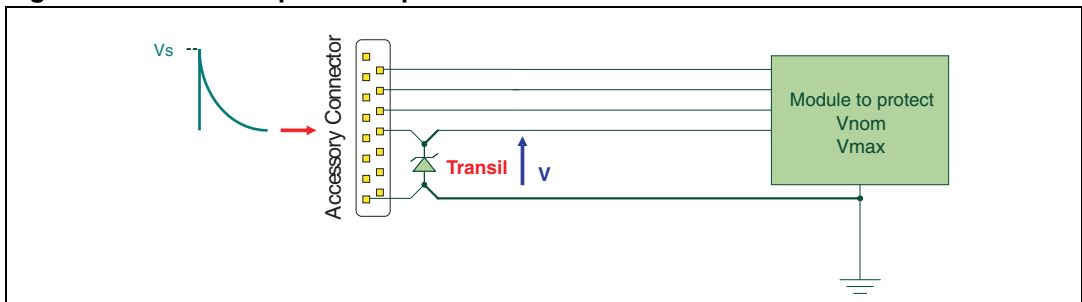

5.1.3 Parasitic coupling due to the loop-effect

In the presence of electromagnetic fields, caused by relay arcing or antenna emissions for example, a loop coupling effect may occur as shown in [Figure 60](#) (red dashed line)

Figure 60. Loop effect representation

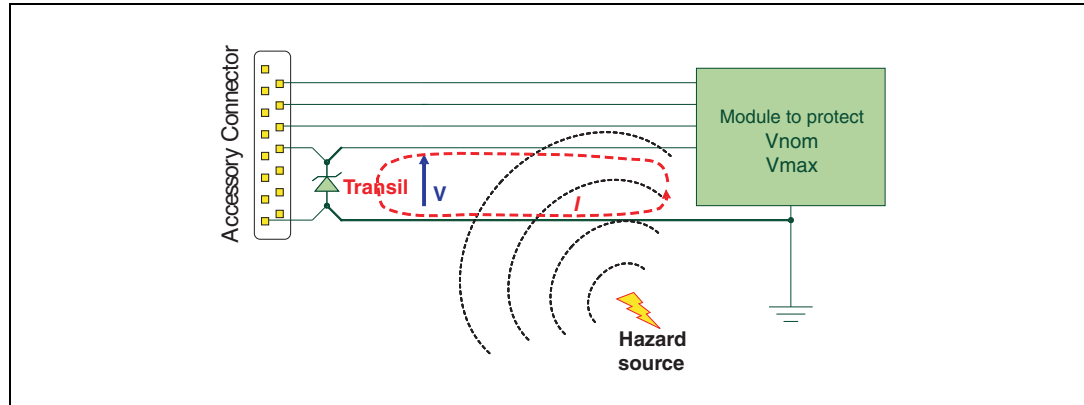

This coupling is dependent on the loop size and the source distance (see [Figure 61](#)).

Figure 61. Electromagnetic field applied to a loop

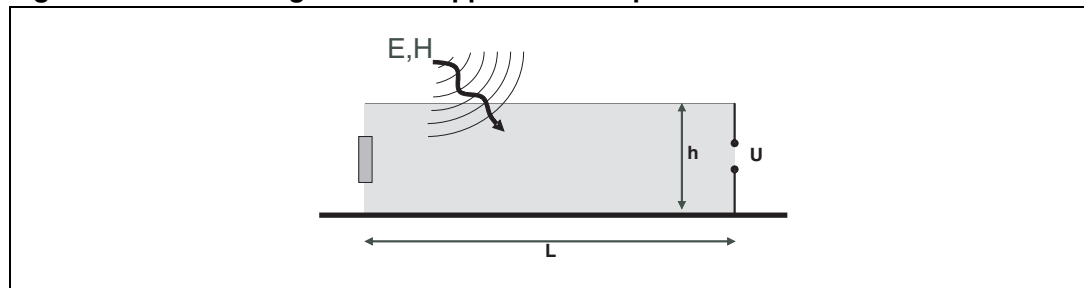

The loop effect voltage U is given by

$$U = \frac{2\pi LhE}{\lambda \sqrt{[1 + (4L/\lambda)^2]} \sqrt{[1 + (4h/\lambda)^2]}}$$

Where H is the magnetic field, E the electric field and λ the wavelength.

U is in Volts, L, h and λ are in meters and E in Volt/meter

The lower the L and h values, the smaller would be the voltage U. That means the smaller would be the parasitic coupling. So the solution is to minimize the track loop between the protection device and the module as shown in [Figure 62](#).

Figure 62. Loop optimization

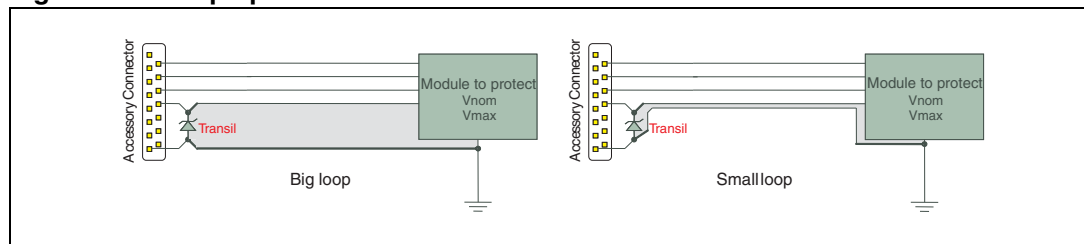
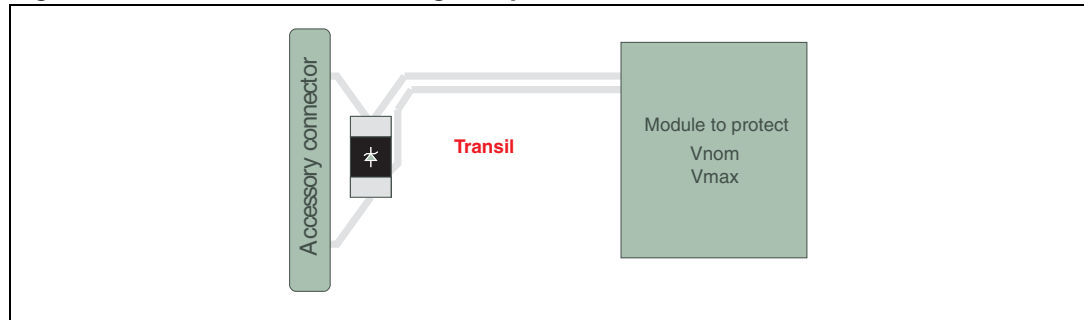

Figure 63 shows a recommended PCB layout using a protection device close to the accessories connector, and with the track loop to the module to protect minimized.

Figure 63. Placement and routing of a protection device



6 Conclusion

Because the automotive environment is a major source of electrical hazards and electronic equipment is becoming more sensitive, caution must be taken when electronic modules are designed.

It is therefore very common to use protection devices to ensure the modules and systems are safe from all hazards generated inside the vehicle.

The choice of the protection device is not easy, and moreover, surges are not well defined even by the standards. This document helps the electronic module designer in the selection of the protection device.

Calculations are sometimes good enough to dimension the protection device but in some cases the surges in practice have to be monitored to determine the best protection.

Some worked examples are given in this document, particularly for the IEC 10605 and ISO 7637-2, pulse 2 and pulse 5a. Thus the way these cases are treated offers the designer a starting point for other kinds of surge, which are yet to be defined.

Beyond the guidance offered for choosing protection devices on the basis of standard surges, other advice is given at the same time such as the protection device routing on PCB, the PCB layout optimization, and the protection device placement.

As a result this document should be helpful in all automotive protection design approaches.

7 Revision history

Table 8. Document revision history

Date	Revision	Changes
21-Feb-2008	1	Initial release.
30-Mar-2010	2	Updated Figure 3 to include IEC 61000 references.
26-Oct-2012	3	Updated example product part numbers.

Please Read Carefully:

Information in this document is provided solely in connection with ST products. STMicroelectronics NV and its subsidiaries ("ST") reserve the right to make changes, corrections, modifications or improvements, to this document, and the products and services described herein at any time, without notice.

All ST products are sold pursuant to ST's terms and conditions of sale.

Purchasers are solely responsible for the choice, selection and use of the ST products and services described herein, and ST assumes no liability whatsoever relating to the choice, selection or use of the ST products and services described herein.

No license, express or implied, by estoppel or otherwise, to any intellectual property rights is granted under this document. If any part of this document refers to any third party products or services it shall not be deemed a license grant by ST for the use of such third party products or services, or any intellectual property contained therein or considered as a warranty covering the use in any manner whatsoever of such third party products or services or any intellectual property contained therein.

UNLESS OTHERWISE SET FORTH IN ST'S TERMS AND CONDITIONS OF SALE ST DISCLAIMS ANY EXPRESS OR IMPLIED WARRANTY WITH RESPECT TO THE USE AND/OR SALE OF ST PRODUCTS INCLUDING WITHOUT LIMITATION IMPLIED WARRANTIES OF MERCHANTABILITY, FITNESS FOR A PARTICULAR PURPOSE (AND THEIR EQUIVALENTS UNDER THE LAWS OF ANY JURISDICTION), OR INFRINGEMENT OF ANY PATENT, COPYRIGHT OR OTHER INTELLECTUAL PROPERTY RIGHT.

UNLESS EXPRESSLY APPROVED IN WRITING BY TWO AUTHORIZED ST REPRESENTATIVES, ST PRODUCTS ARE NOT RECOMMENDED, AUTHORIZED OR WARRANTED FOR USE IN MILITARY, AIR CRAFT, SPACE, LIFE SAVING, OR LIFE SUSTAINING APPLICATIONS, NOR IN PRODUCTS OR SYSTEMS WHERE FAILURE OR MALFUNCTION MAY RESULT IN PERSONAL INJURY, DEATH, OR SEVERE PROPERTY OR ENVIRONMENTAL DAMAGE. ST PRODUCTS WHICH ARE NOT SPECIFIED AS "AUTOMOTIVE GRADE" MAY ONLY BE USED IN AUTOMOTIVE APPLICATIONS AT USER'S OWN RISK.

Resale of ST products with provisions different from the statements and/or technical features set forth in this document shall immediately void any warranty granted by ST for the ST product or service described herein and shall not create or extend in any manner whatsoever, any liability of ST.

ST and the ST logo are trademarks or registered trademarks of ST in various countries.

Information in this document supersedes and replaces all information previously supplied.

The ST logo is a registered trademark of STMicroelectronics. All other names are the property of their respective owners.

© 2012 STMicroelectronics - All rights reserved

STMicroelectronics group of companies

Australia - Belgium - Brazil - Canada - China - Czech Republic - Finland - France - Germany - Hong Kong - India - Israel - Italy - Japan - Malaysia - Malta - Morocco - Philippines - Singapore - Spain - Sweden - Switzerland - United Kingdom - United States of America

www.st.com