



L9352B coil driver for ABS/ESP applications:
current regulated channel analysis

Introduction

This document describes a detailed analysis on the current regulated channels of the ST coil driver L9352B. This intelligent quad-low side switch is typically used to drive inductive loads such as on-off valves of the hydraulic modulator of ABS^(a)/ESP^(b) control unit.

-
- a. Antilock Brake System (ABS).
 - b. Electronic Stability Program (ESP).

Contents

1	L9352B overview	5
2	Test bench layout	7
3	Linearity relationship test	8
4	Opening/closing time of the INLET valves versus duty-cycle of the hold-phase	11
5	Virtual current control loop on the Q1, Q2 channels of L9352B	13
6	Revision history	17

List of tables

Table 1.	INLET valve opening/closing time versus duty-cycle strategy	12
Table 2.	Results of the first operative condition under test.	14
Table 3.	Results of the second operative condition under test.	14
Table 4.	Comparison between the current on loads driven by reg. channels and unreg. channels before and after the VCCL	15
Table 5.	Results of the last operative condition under test.	16
Table 6.	Document revision history	17

List of figures

Figure 1. L9352B application diagram 5

Figure 2. Comparison between the "ideal" linear relationship and the experimental data 6

Figure 3. Test bench layout used to characterize current control channels of L9352B. 7

Figure 4. Current waveform produced on the load by the test coil energizing strategy 8

Figure 5. Comparison between the "ideal" linear relationship and the experimental data
for two different load conditions 9

Figure 6. Coil current driven by means of L9352B in a typical ABS mission profile: coils on valves . . 9

Figure 7. Coil current driven by means of L9352B in a typical ABS mission profile: stand-alone coils. 10

Figure 8. "Pull-in"- "hold" phase duty-cycle strategy traditionally adopted to drive on-off valves. . . 11

Figure 9. Evaluation of the VCCL on the L9352B unregulated channels:
first test condition block scheme 13

Figure 10. Evaluation of the VCCL on the L9352B unregulated channels:
last test condition block scheme 15

1 Root Part Number 1 overview

The Root Part Number 1 (see [Figure 1](#)) is designed to drive inductive loads (e.g. relays, electromagnetic valves, etc.) in low side configuration. Integrated active Zener-clamp, for channels 1 and 2, or free wheeling diodes, for channels 3 and 4, allow the recirculation of the current of the inductive loads during the off-state of the DMOS.

All four channels are monitored with a status output. All wiring to the loads and supply pins of the device are controlled.

The device is self-protected against short circuit at the outputs and over-temperature. Channels 3 and 4 work as current regulator.

A PWM signal, with a 2 kHz frequency, on the input defines the target for the output current, in particular, there is a linear relationship between the duty-cycle of the PWM input signal and the target value of the current (see [Figure 2](#)).

The current is measured during recirculation phase of the load, that is, during the off-state of the DMOS. A sensing resistor, integrated in the IC and placed on the drain of the DMOS and of the free-wheeling diode, is devoted to measure the current.

The benefit of the current regulation is an optimization of the PWM duty-cycle strategy against changes in the load conditions (e.g. temperature gradient and as a consequence coil resistor increases). Moreover, a test mode compares the differences between the two regulators. This "drift" test compares the output PWM of the regulators. Using this feature a drift of the load during lifetime can be detected.

Figure 1. Root Part Number 1 application diagram

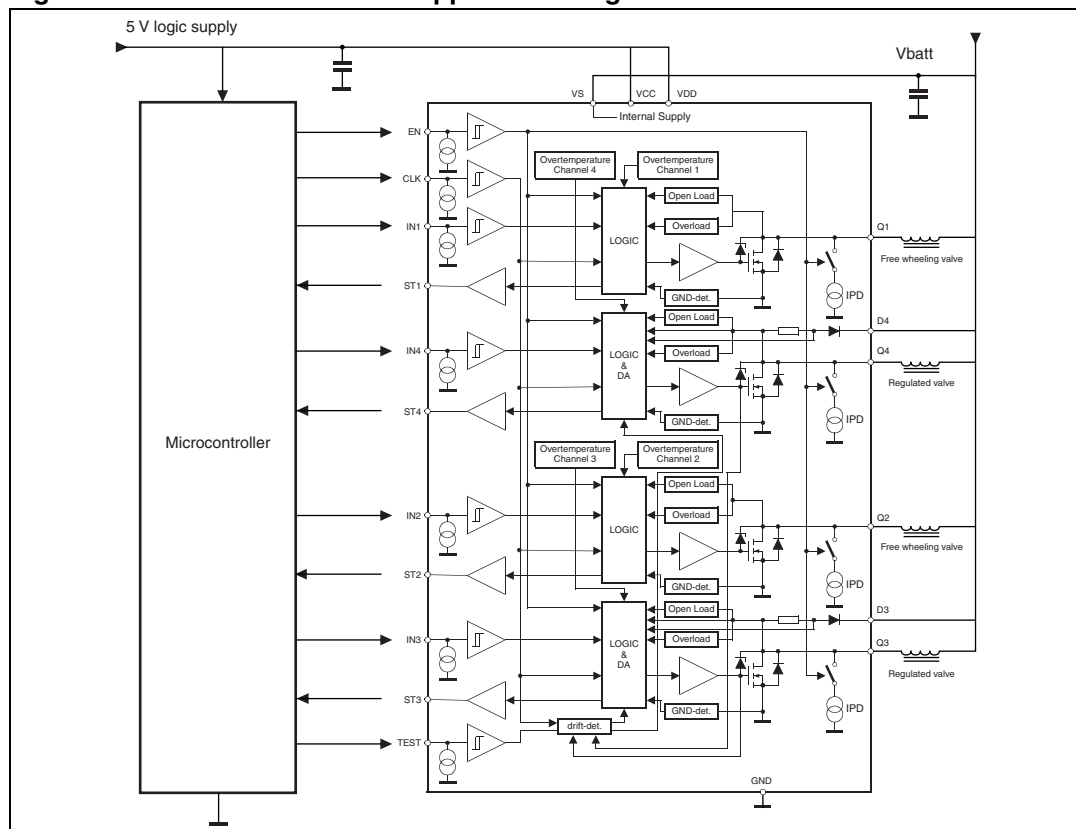
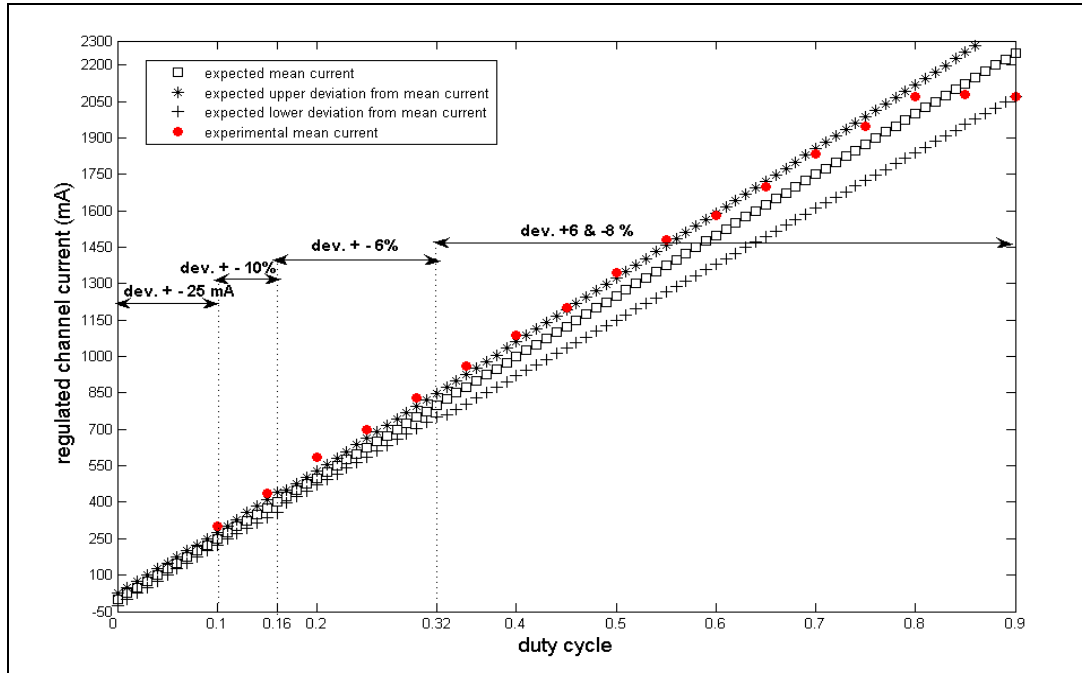

Figure 2. Comparison between the "ideal" linear relationship and the experimental data



2 Test bench layout

As shown in the *Figure 2*, the accuracy in the current control of the Root Part Number 1 depends on the range of values of the PWM input signal duty-cycle. Basically, for duty-cycle greater than 16% it is possible to consider a current control accuracy of 6 %. The experimental data shown in the *Figure 2* (i.e. red point) are related to the following test layout (see *Figure 3*):

- dSPACE Microautobox
- LEM Sensor LAH 25-NP
- INLET valves of the 8.0 ABS/ESP Bosch control unit
- coils with a resistor of 4.6 Ohm
- coil energizing frequency (i.e. valve opening/closing frequency) of 5 Hz
- coil energizing strategy:
 - for the first 20 ms, duty-cycle = 0.1 %
 - for the next 30 ms, duty-cycle = 90 %
 - for the last 150 ms, duty-cycle = [5:5:90] %

The current waveform produced by this coil energizing strategy is shown in the *Figure 4*.

Figure 3. Test bench layout used to characterize current control channels of L9352B.

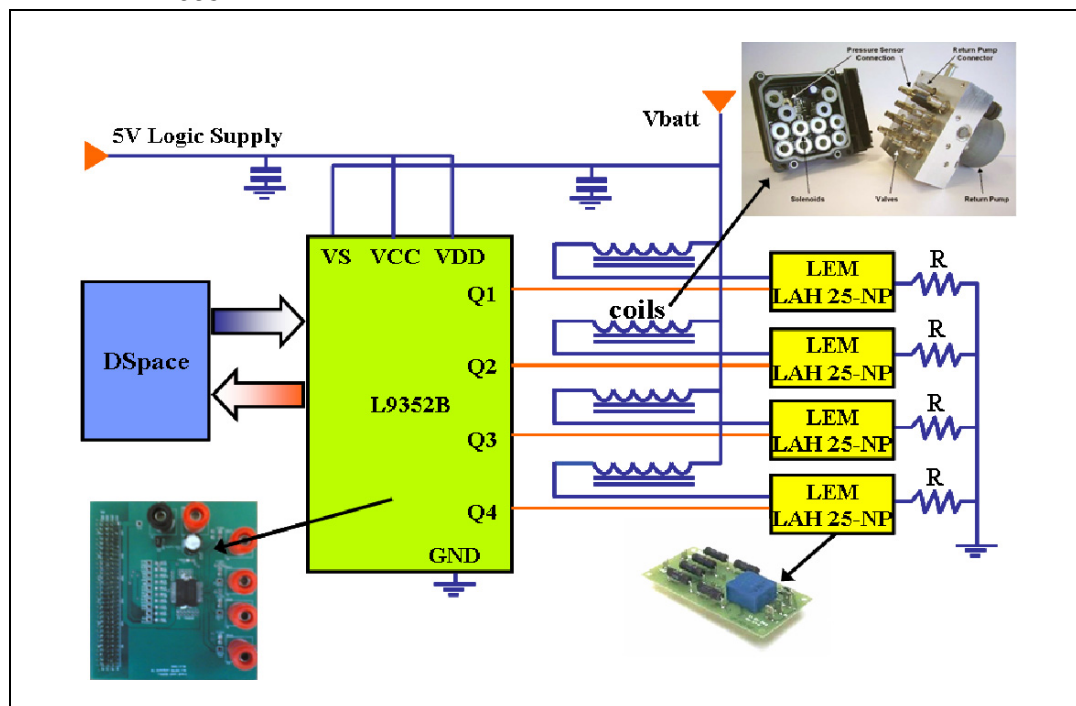

3 Linearity relationship test

The measurements of the values of the mean current to compare with the "ideal" linear relationship of the Root Part Number 1 current control channels have been carried out on the "hold-phase" of the current waveform. The *Figure 5* describes a comparison between the results obtained on two different loads:

- stand-alone coils (i.e. blue stars, crosses and balls);
- coils on the valves (i.e. red stars, crosses and balls);

The main difference between the two considered different load conditions is that for the coils stand alone you have an equivalent R-L circuit with a fixed inductance.

On the other hand, when as load you consider a coil on a valve, from the point of view of the equivalent R-L circuit there is an inductance changing with the opening/closing dynamics of the valve.

As the results of our analysis show in the *Figure 5, 6 and 7* the current control loop of the Q3 and Q4 channels has been conceived in order to drive variable inductance loads, in fact, the spread between maximum and minimum values of the current for a fixed duty-cycle value of the PWM input signal is minimum in the case of a variable inductance load.

Figure 4. Current waveform produced on the load by the test coil energizing strategy

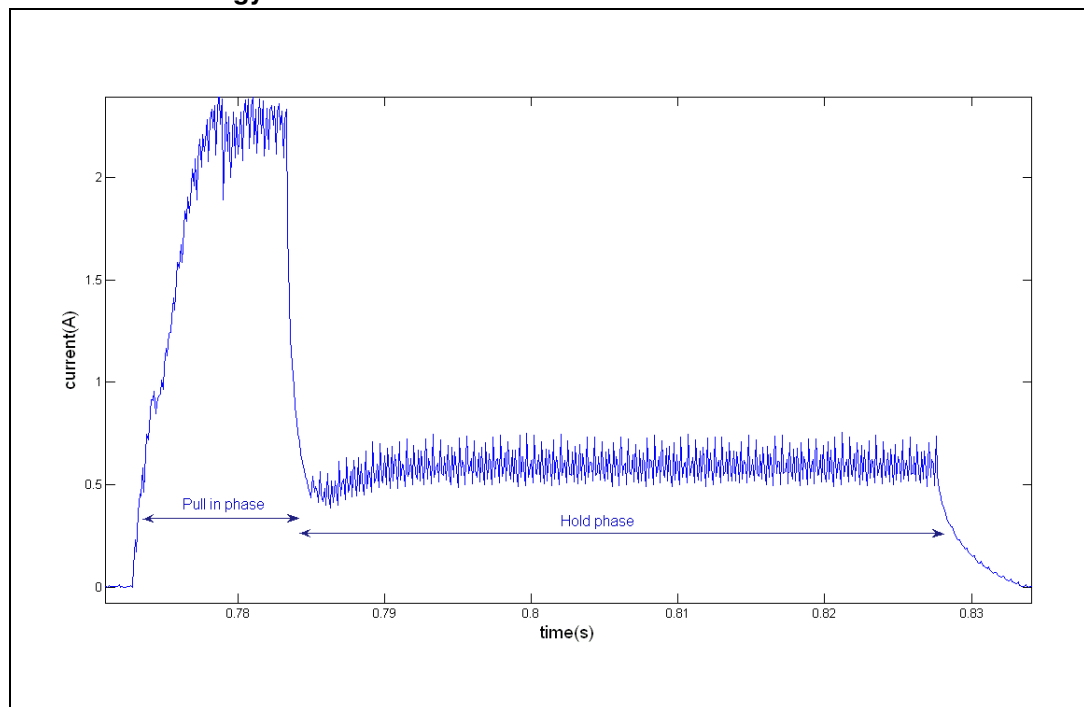

Figure 5. Comparison between the "ideal" linear relationship and the experimental data for two different load conditions

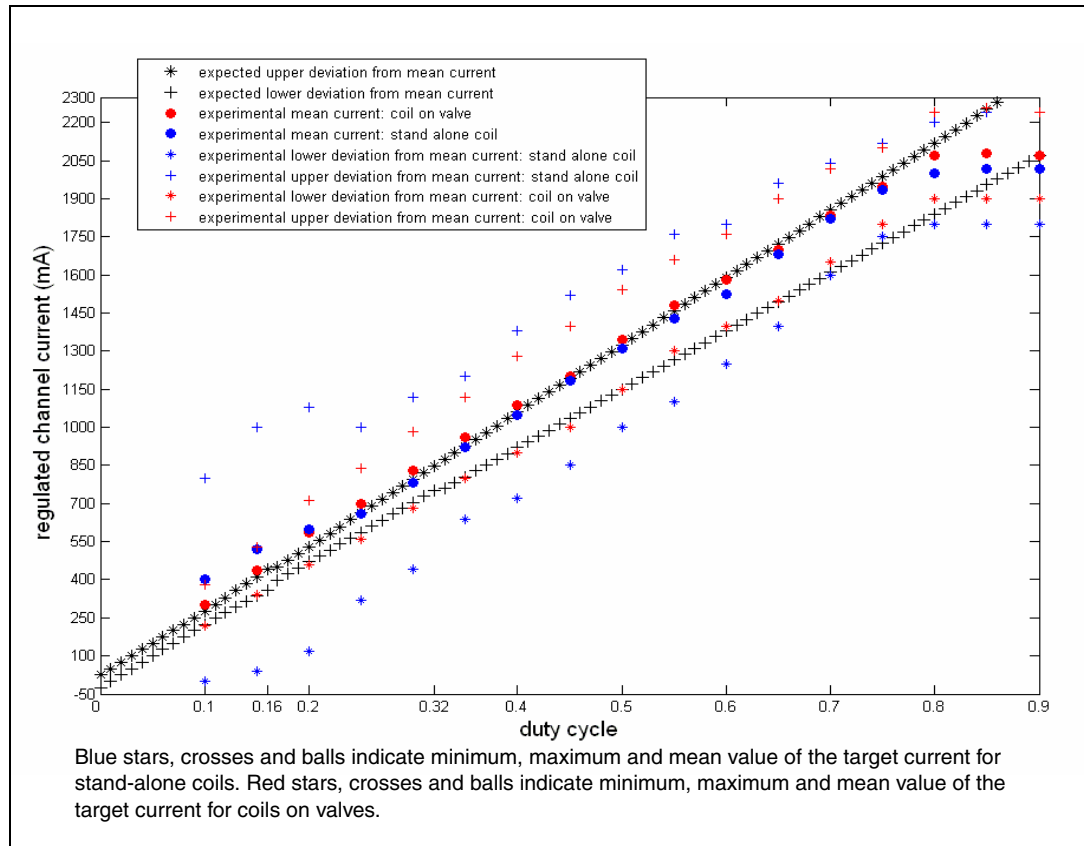

Figure 6. Coil current driven by means of L9352B in a typical ABS mission profile: coils on valves

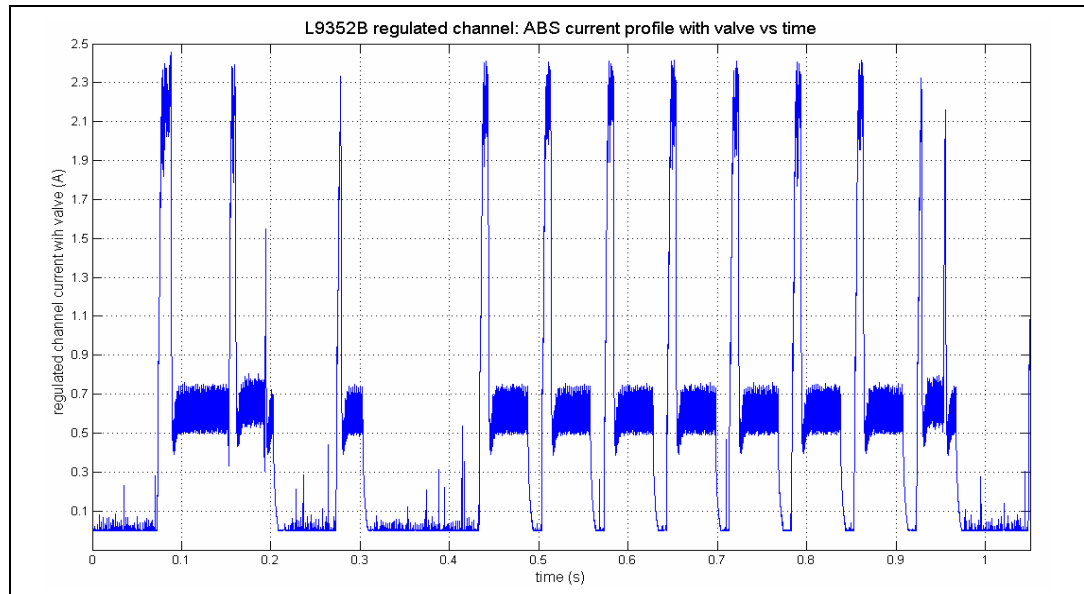
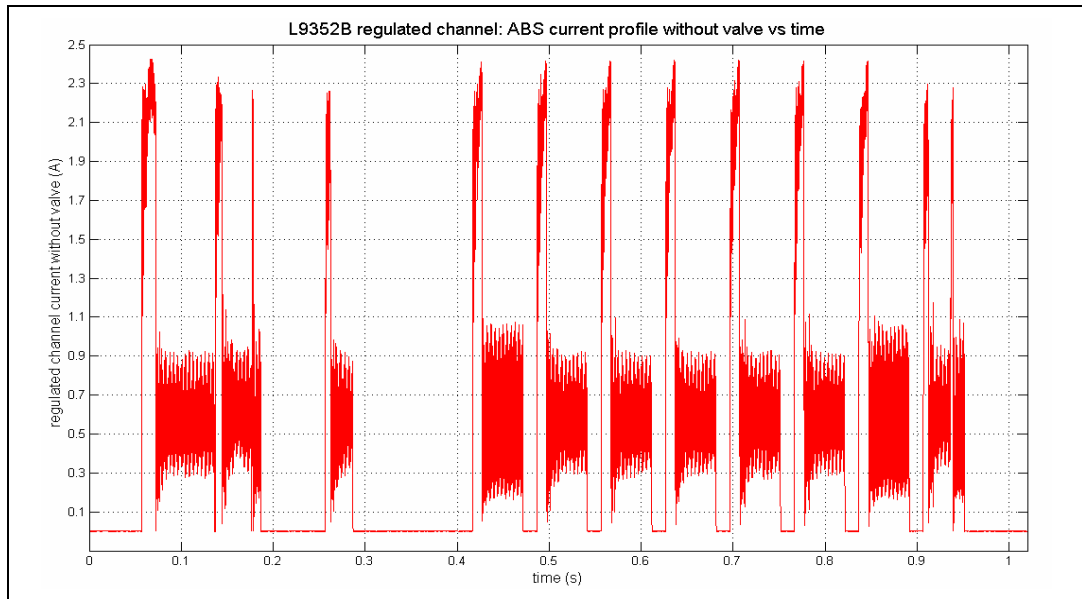

Figure 7. Coil current driven by means of L9352B in a typical ABS mission profile: stand-alone coils



4 Opening/closing time of the INLET^(a) valves versus duty-cycle of the hold-phase

The conventional strategy adopted to drive on-off valves used in the hydraulic modulator of ABS/ESP control unit is described in the [Figure 8](#). The "pull-in" phase corresponds to the maximum values of duty-cycle applied for the first part of the valve opening/closing time. This phase guarantees the opening/closing of the valve against stiction phenomena due, for example, to the aging of the valve, to the dirt into the brake fluid, to the stiffness change of the valve spring and so on.

The "hold" phase corresponds to the duty-cycle value that is necessary to maintain the valve opened/closed. Clearly this value is less than that used for the "pull-in" phase, because the force required to overcome the static friction is greater than the force required to overcome the dynamic one. Obviously, this kind of duty-cycle strategy is power saving too.

Figure 8. "Pull-in"- "hold" phase duty-cycle strategy traditionally adopted to drive on-off valves

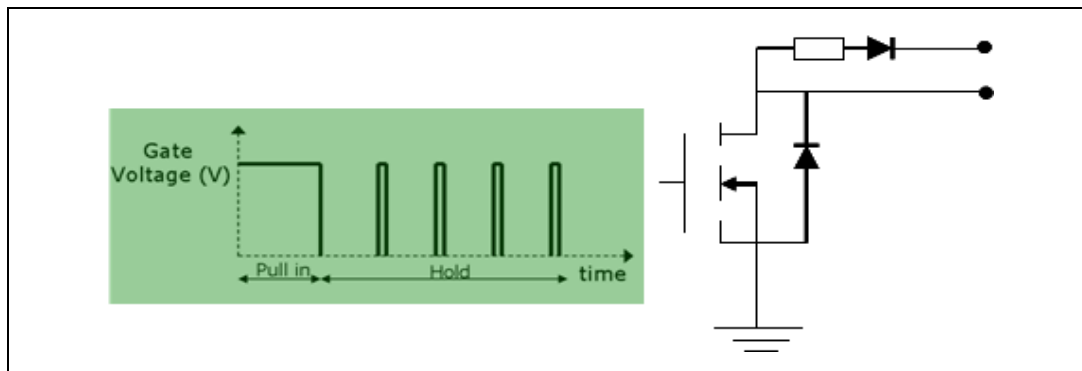

Several tests have been carried out fixing the coil energizing frequency at 5 Hz and the time strategy at:

- for the first 20 ms, duty-cycle = 0.1 %
- for the next 30 ms, duty-cycle = 90 %
- for the last 150 ms, duty-cycle = [5:5:90] %

The different duty-cycle configurations considered are summarized on the first column of the [Table 1](#). In these tests, we measured the opening and closing time of the INLET valve, and, in addition, the time in which armature-piston of the valve starts its motion. An interesting result comes out. While the armature-piston motion and the closing time of the INLET valve are not affected by the duty-cycle configurations, the opening time is affected. In particular, this increases of 0.5 ms for each 5 % of duty-cycle increase of the "hold" phase.

a. Take into account that the INLET valves of an ABS/ESP hydraulic modulator are on-off valves normally opened and normally controlled by a current control loop. On the hydraulic modulator there are also OUTLET valves. These valves normally closed do not require a current control loop but conventional low-side switch.

Table 1. INLET valve opening/closing time versus duty-cycle strategy

Duty-cycle strategy [“pull-in”_”hold”]	Armature-piston motion [ms]	Closing time [ms]	Opening time [ms]
20_75	1.5	7	5
20_80	1.5	6.5	5
20_85	1.5	6	5
20_90	1.5	6	5
25_75	1.5	7	5.5
25_80	1.5	6.5	5.5
25_85	1.5	6	5.5
25_90	1.5	6	5.5
30_75	1.5	7	6
30_80	1.5	6.5	6
30_85	1.5	6	6
30_90	1.5	6	6
35_75	1.5	7	6.5
35_80	1.5	6.5	6.5
35_85	1.5	6	6.5
35_90	1.5	6	6.5

5 Virtual current control loop on the Q1, Q2 channels of Root Part Number 1

In this section we describe an analysis, done on the unregulated channels Q_1 , Q_2 of the Root Part Number 1, aimed to understand the limits of a virtual current control loop on the same channels. The idea is to tune the duty-cycle of the Q_1 , Q_2 channels on a measurement of the duty-cycle observed on the regulated channels Q_3 , Q_4 . Clearly, we considered same load conditions, that is, for both the regulated and unregulated channels of the Root Part Number 1, we considered same coils, same INLET valves. Furthermore, to balance the difference of PWM signal frequency on the Root Part Number 1 channels, the unregulated ones (i.e. Q_1 , Q_2) have been driven with a frequency of 3.9 kHz^(b). In order to allow the current recirculation during the off-state of the Q_1 , Q_2 channels, external free-wheeling diodes have been used to link the channel output and V_{bat} . As free-wheeling diode we have considered the ST power Schottky diodes 1N5817.

Figure 9. Evaluation of the VCCL on the L9352B unregulated channels: first test condition block scheme

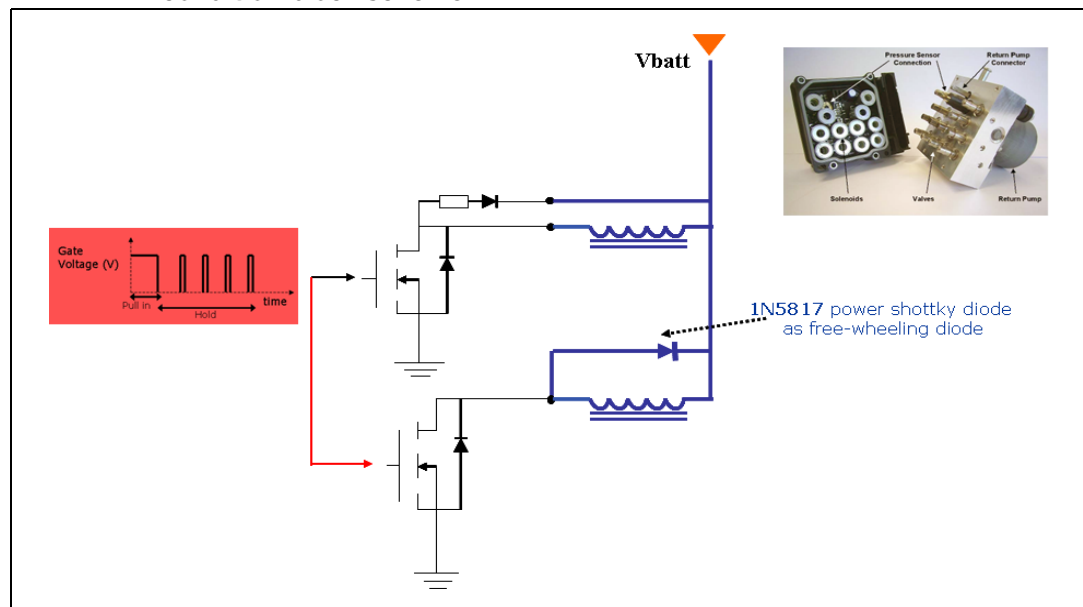

As first operative condition for our tests (see [Figure 9](#)) we can refer to the following data:

- INLET valve opening/closing frequency of 1Hz
- for the first 450 ms, duty-cycle = 0.1 %
- for the next 50 ms, duty-cycle = 90 %
- for the last 500 ms, duty-cycle = [15:10:75] %

The [Table 2](#) shows the results related to this first operative condition that we considered for our tests. As we can see in the last four columns, the difference between the mean current on the load driven by the unregulated channel and the mean current on the load driven by the regulated channel reduces as the set-point, that is, the duty of the hold phase increases.

b. Take into account that the ideal frequency of the output PWM signal of the current regulated channels (i.e. Q3, Q4) is the (clock frequency)/64, that is, 3.9 kHz for a clock frequency of 250 kHz.

Similar results have been observed considering another operative condition, characterized by a different duty-cycle strategy (see [Table 3](#)). Clearly, the duty-cycle applied on the unregulated channels in both the operative conditions under test is the same measured on the regulated channel. See columns 2, 3 of the following tables to understand the difference between the two duty-cycles applied on the unregulated and regulated channels of the L9352B on the same load conditions.

As second operative condition for our tests (see [Figure 9](#)) we can refer to the following data:

- INLET valve opening/closing frequency of 1 Hz
- for the first 500 ms, duty-cycle = 0.1 %
- for the last 500 ms, duty-cycle = [15:10:75] %

The [Table 2](#) and [3](#) show the results of a comparison between the mean current on the loads driven by the regulated channels of Root Part Number 1 and the unregulated ones. These last have been trained on the output duty-cycle of the regulated channels.

Table 2. Results of the first operative condition under test

Input duty (hold phase)	Unreg. ch. output duty (before the manual regulation)	Reg. ch. output duty	Unreg. ch. mean current [mA]	Unreg. ch. pk-to-pk current [mA]	Reg. ch. mean current [mA]	Reg. ch. pk-to-pk current [mA]
0.15	0.83	0.75	520	280	390	360
0.25	0.73	0.65	749	360	660	360
0.35	0.64	0.53	990	400	920	480
0.45	0.55	0.41	1200	480	1200	480
0.55	0.44	0.26	1480	480	1480	480
0.65	0.35	0.1	1700	480	1740	440
0.75	0.23	0.09	1780	520	1760	480

Table 3. Results of the second operative condition under test

Input duty (hold phase)	Unreg. ch. output duty (before the manual regulation)	Reg. ch. output duty	Unreg. ch. mean current [mA]	Unreg. ch. pk-to-pk current [mA]	Reg. ch. mean current [mA]	Reg. ch. pk-to-pk current [mA]
0.15	0.83	0.75	530	320	390	360
0.25	0.73	0.65	780	400	660	360
0.35	0.64	0.53	980	440	920	440
0.45	0.53	0.39	1240	480	1200	480
0.55	0.44	0.25	1460	560	1480	520
0.65	0.34	0.09	1630	440	1740	480
0.75	0.25	0.09	1630	440	1820	480

Just to highlight the results obtained by this analysis, it is important to summarize the difference in the coil current of the unregulated channels of Root Part Number 1 before and

after the regulation inspired to the duty-cycle value carried out by the regulated channels of the same device.

In [Table 4](#) we can see the results of a comparison between the mean current on the loads, driven by the L9352B regulated channels and L9352B unregulated channels before and after the VCCL regulation.

Table 4. Comparison between the current on loads driven by reg. channels and unreg. channels before and after the VCCL

Hold phase duty	Mean current on the cycle-time for the reg. ch. [mA]	Mean current on the cycle-time for the unreg. ch. -- before the regulation -- [mA]	Mean current on the cycle-time for the unreg. ch. -- after the regulation -- [mA]
0.35	530	450	560
0.45	660	550	670

As last operative condition considered in our tests we can refer to the following data and the [Figure 10](#):

- INLET valve opening/closing frequency of 1 Hz
- for the first 450 ms, duty-cycle = 0.1 %
- for the next 50 ms, duty-cycle = 90 %
- for the last 500 ms, duty-cycle = [15:10:75] %

The main idea is to increase the resistance of the loads of about the 15 %. The initial value of 4.8 Ohm, that is, 4.6 Ohm of the coil resistor plus 0.2 Ohm of Rds-ON of the DMOS has been increased of 0.6 Ohm. So doing, we simulated a gradient temperature of about 35°. For this calculation we referred to the formula of the resistance of the chopper versus the temperature:

$$R_{last} = R_{initial}(1 + 0.004\Delta T)$$

From the results shown in the table 7-4, it comes out that the unregulated channels maintains a satisfactory tracking capability of the current values driven on the loads also in simulated conditions of temperature gradient.

Figure 10. Evaluation of the VCCL on the L9352B unregulated channels: last test condition block scheme

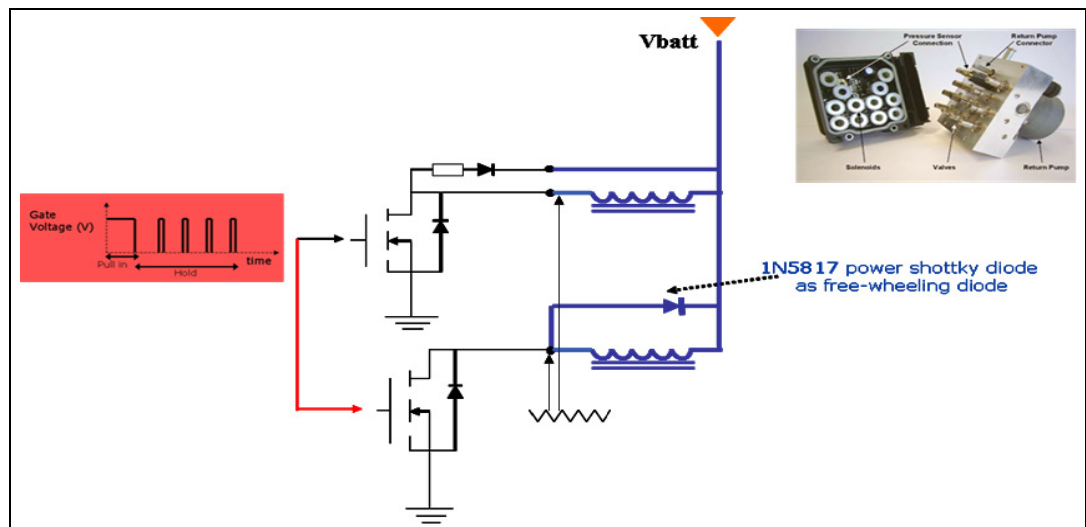

In [Table 5](#) comparison between the mean current on the loads driven by the regulated channels of Root Part Number 1 and the unregulated ones. These last have been trained on the output duty-cycle of the regulated channels.

Table 5. Results of the last operative condition under test

Input duty (hold phase)	Unreg. ch. output duty (before the manual regulation)	Reg. ch. output duty	Unreg. ch. mean current [mA]	Unreg. ch. pk-to-pk current [mA]	Reg. ch. mean current [mA]	Reg. ch. pk-to-pk current [mA]
0.15	0.83	0.73	500	220	400	260
0.25	0.73	0.6	730	280	670	300
0.35	0.64	0.46	1000	380	945	360
0.45	0.54	0.32	1180	440	1220	400
0.55	0.44	0.09	1400	480	1480	400
0.65	0.35	0.09	1400	480	1620	440
0.75	0.23	0.09	1400	480	1600	400

6 Revision history

Table 6. Document revision history

Date	Revision	Changes
25-Jun-2008	1	Initial release.
17-Sep-2013	2	Updated Disclaimer.

Please Read Carefully:

Information in this document is provided solely in connection with ST products. STMicroelectronics NV and its subsidiaries ("ST") reserve the right to make changes, corrections, modifications or improvements, to this document, and the products and services described herein at any time, without notice.

All ST products are sold pursuant to ST's terms and conditions of sale.

Purchasers are solely responsible for the choice, selection and use of the ST products and services described herein, and ST assumes no liability whatsoever relating to the choice, selection or use of the ST products and services described herein.

No license, express or implied, by estoppel or otherwise, to any intellectual property rights is granted under this document. If any part of this document refers to any third party products or services it shall not be deemed a license grant by ST for the use of such third party products or services, or any intellectual property contained therein or considered as a warranty covering the use in any manner whatsoever of such third party products or services or any intellectual property contained therein.

UNLESS OTHERWISE SET FORTH IN ST'S TERMS AND CONDITIONS OF SALE ST DISCLAIMS ANY EXPRESS OR IMPLIED WARRANTY WITH RESPECT TO THE USE AND/OR SALE OF ST PRODUCTS INCLUDING WITHOUT LIMITATION IMPLIED WARRANTIES OF MERCHANTABILITY, FITNESS FOR A PARTICULAR PURPOSE (AND THEIR EQUIVALENTS UNDER THE LAWS OF ANY JURISDICTION), OR INFRINGEMENT OF ANY PATENT, COPYRIGHT OR OTHER INTELLECTUAL PROPERTY RIGHT.

ST PRODUCTS ARE NOT DESIGNED OR AUTHORIZED FOR USE IN: (A) SAFETY CRITICAL APPLICATIONS SUCH AS LIFE SUPPORTING, ACTIVE IMPLANTED DEVICES OR SYSTEMS WITH PRODUCT FUNCTIONAL SAFETY REQUIREMENTS; (B) AERONAUTIC APPLICATIONS; (C) AUTOMOTIVE APPLICATIONS OR ENVIRONMENTS, AND/OR (D) AEROSPACE APPLICATIONS OR ENVIRONMENTS. WHERE ST PRODUCTS ARE NOT DESIGNED FOR SUCH USE, THE PURCHASER SHALL USE PRODUCTS AT PURCHASER'S SOLE RISK, EVEN IF ST HAS BEEN INFORMED IN WRITING OF SUCH USAGE, UNLESS A PRODUCT IS EXPRESSLY DESIGNATED BY ST AS BEING INTENDED FOR "AUTOMOTIVE, AUTOMOTIVE SAFETY OR MEDICAL" INDUSTRY DOMAINS ACCORDING TO ST PRODUCT DESIGN SPECIFICATIONS. PRODUCTS FORMALLY ESCC, QML OR JAN QUALIFIED ARE DEEMED SUITABLE FOR USE IN AEROSPACE BY THE CORRESPONDING GOVERNMENTAL AGENCY.

Resale of ST products with provisions different from the statements and/or technical features set forth in this document shall immediately void any warranty granted by ST for the ST product or service described herein and shall not create or extend in any manner whatsoever, any liability of ST.

ST and the ST logo are trademarks or registered trademarks of ST in various countries.

Information in this document supersedes and replaces all information previously supplied.

The ST logo is a registered trademark of STMicroelectronics. All other names are the property of their respective owners.

© 2013 STMicroelectronics - All rights reserved

STMicroelectronics group of companies

Australia - Belgium - Brazil - Canada - China - Czech Republic - Finland - France - Germany - Hong Kong - India - Israel - Italy - Japan - Malaysia - Malta - Morocco - Philippines - Singapore - Spain - Sweden - Switzerland - United Kingdom - United States of America

www.st.com