**Resistor-Capacitor (RC) acquisition principle
for STM8 touch sensing applications**

Introduction

In applications requiring user interface, capacitive touch-sensitive controls become the solution to replace conventional electro-mechanical switches.

STMicroelectronics has developed a complete touch sensing software library to transform any 8-bit STM8 microcontroller into a capacitive touchkey controller.

This application note describes the RC time constant acquisition principle used by the touch sensing library provided in the STM8L-TOUCH-LIB and the STM8S-TOUCH-LIB software packages (see [Table 1](#)). For more details, please refer to www.st.com/mcu web site.

This touch sensing software library allows to detect any finger touch by controlling the charge/discharge timing cycle of an RC network formed by a single resistor and the touch electrode capacitance. Any variation in the RC timing due to the electrode capacity change is detected then filtered and eventually reported to a host system using dedicated I/Os or I²C/SPI interface.

The bill of material is low-cost as only one resistor is needed per touch channel to enable this function.

Table 1. Applicable softwares

Type	Part numbers
STM8 Firmware	STM8L-TOUCH-LIB
	STM8S-TOUCH-LIB

Contents

- 1 RC acquisition principle 5**
- 2 Hardware implementation 7**
- 3 Firmware implementation 8**
 - 3.1 Charge time measurement principle 8
 - 3.1.1 Basic measurement 8
 - 3.1.2 Oversampling 8
 - 3.2 Input voltage measurement principle 9
 - 3.3 Touch effect 10
 - 3.4 Multi acquisitions and high-frequency (HF) noise rejection 11
- 4 Revision history 13**

List of tables

Table 1.	Applicable softwares	1
Table 2.	Capacitance charge/discharge measurement steps.	10
Table 3.	Document revision history	13

List of figures

Figure 1.	Voltage applied on an RC network	5
Figure 2.	Measuring the charge time	5
Figure 3.	Touch acquisition	6
Figure 4.	Capacitive touch sensing implementation example	7
Figure 5.	Timer counter values	8
Figure 6.	Input voltage measurements	9
Figure 7.	Capacitance charge/discharge measurements	9
Figure 8.	Touch effect example	10
Figure 9.	Types of acquisitions	11
Figure 10.	HF noise rejection example 1	11
Figure 11.	HF noise rejection example 2	12
Figure 12.	HF noise rejection example 3	12

1 RC acquisition principle

The RC acquisition method is used to detect the finger touch of any capacitive touch sensor (key, wheel or slider) by measuring the small variation of the touch electrode capacitance (C). This capacitance is periodically charged and discharged through a fixed resistor (R) (see [Figure 1](#)).

The capacitance value depends on the following parameters: electrode area (A), relative dielectric constant of the insulator (ϵ_R), the relative permittivity of air (ϵ_0) and the distance between the two electrodes (d). The capacitance value is summarized with the formula:

$$C = \frac{\epsilon_R \epsilon_0 A}{d}$$

Figure 1. Voltage applied on an RC network

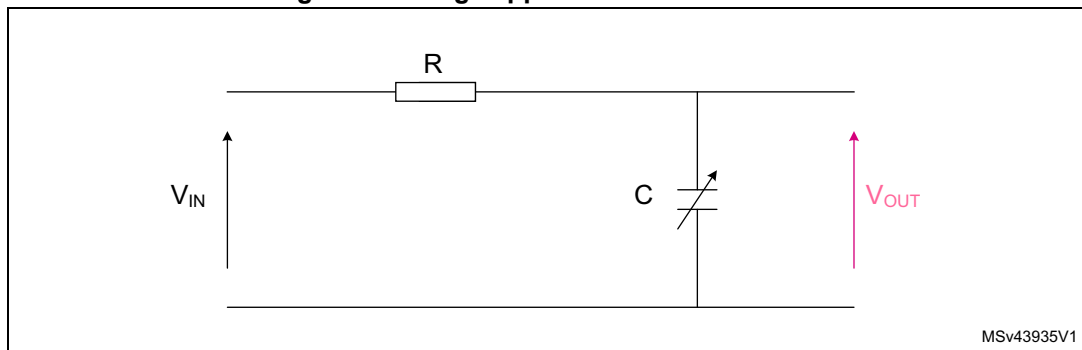

A fixed voltage is applied on V_{IN} . The V_{OUT} voltage increases or decreases proportionally to the capacitance value as shown in [Figure 2](#).

Figure 2. Measuring the charge time

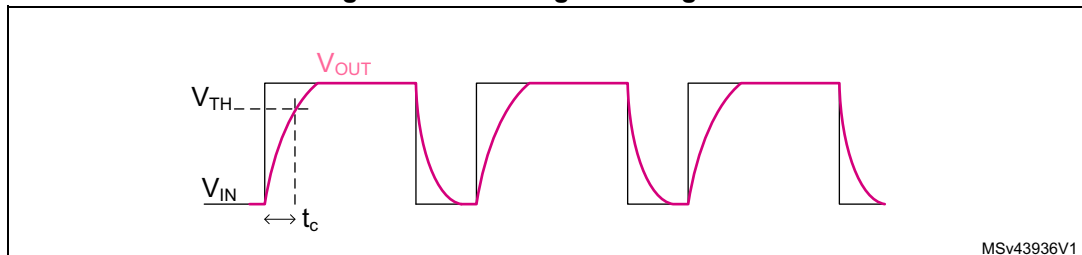

The capacitance value (C) is calculated by measuring the charge time (t_c) the V_{OUT} voltage requires to reach the threshold V_{TH} .

In touch sensing applications, the capacitance value (C) is the addition of a fixed capacitance (electrode capacitance, C_X) and the capacitance added by the finger touch (C_T , touch capacitance) when it touches or is close to the electrode. The electrode capacitance must be kept as low as possible to ensure touch detection which is only a variation of a few picofarads (typically 5pF).

Using this acquisition principle, it is possible to determine if a finger is “touching” the electrode or not.

Figure 3. Touch acquisition

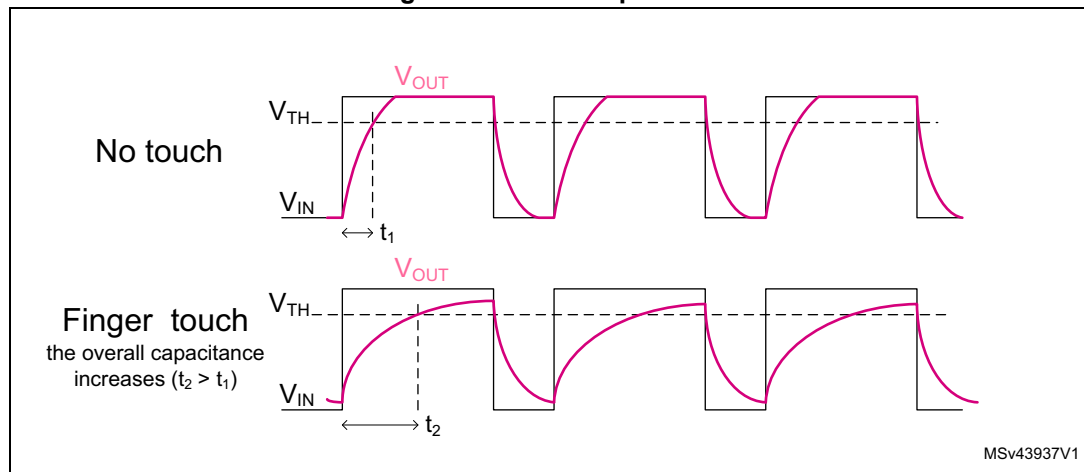

This is the basic principle used in the acquisition layer of the ST touch sensing library to detect a finger touch.

2 Hardware implementation

Figure 4 illustrates an implementation example. The capacitive finger touch is detected by measuring the charge/discharge of the RC network composed of R1, R2 and electrode capacitance (C_x) in parallel with the finger capacitance (C_T) (approximately 5pF).

There is only one Load I/O pin for all the electrodes. The resistors R1 and R2 must be placed as close as possible to the MCU. The resistor R1 (between hundreds Ohms to a few MOhms) is the main resistor used to adjust the electrode sensitivity to touch. The resistor R2 (10k Ω) is optional and is used to reduce noise sensitivity.

Figure 4. Capacitive touch sensing implementation example

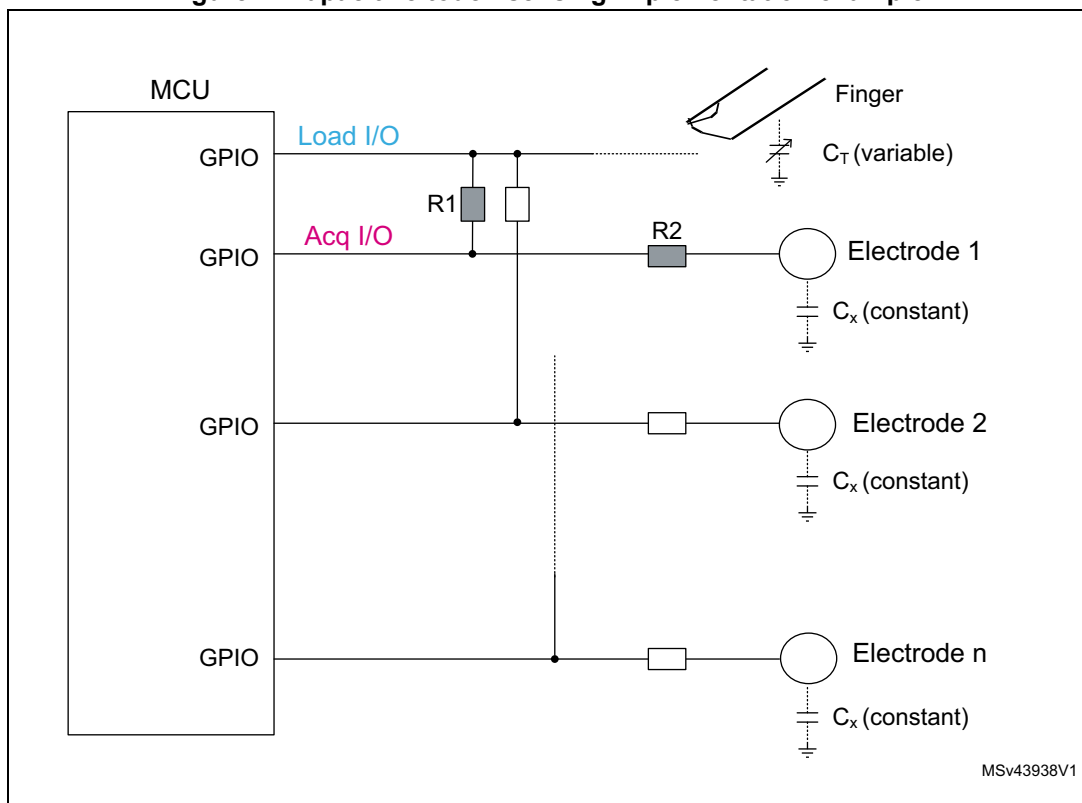

For more information, refer to the application note *Guidelines for designing touch sensing applications with surface sensors* (AN4312).

3 Firmware implementation

This section describes the implementation of the RC acquisition principle in the ST touch sensing firmware library.

3.1 Charge time measurement principle

The charge time measurement must be accurate enough to ensure a robust capacitive sensing application. There are two common ways to measure the charge time:

- The first solution is using an input capture (IC) timer which is triggered when the voltage reaches the threshold level. This approach offers a time measurement resolution which is directly linked to the timer counter frequency. However, as one input capture channel is required per electrode, standard MCUs are not compatible with this type of capacitive sensing application.
- The second solution uses both a simple timer (without IC capability) and a simple software sequence which regularly checks if the voltage on the acquisition I/O has reached the threshold level. In this case, the time resolution measurement is equal to the number of CPU cycles used to execute a complete loop of the software sequence. This measurement approach introduces some jitter which is not compatible with the capacitive sensing acquisition. However, a large number of electrodes can be implemented as there are no hardware constraints.

A variant of the second solution obtains a fixed measurement resolution equal to the CPU frequency (f_{CPU}) by using an adaptive software sequence. This is the approach used in the ST touch sensing firmware library and is described below.

3.1.1 Basic measurement

A general purpose timer performs the charge time measurement. The timer counter start value is saved (or reset) at the beginning of the capacitance charge. When the voltage on the acquisition I/O (Acq I/O) reaches a certain threshold level (V_{TH}), the current timer counter value is saved. The difference of the two time counter values gives the charge or discharge time.

Figure 5. Timer counter values

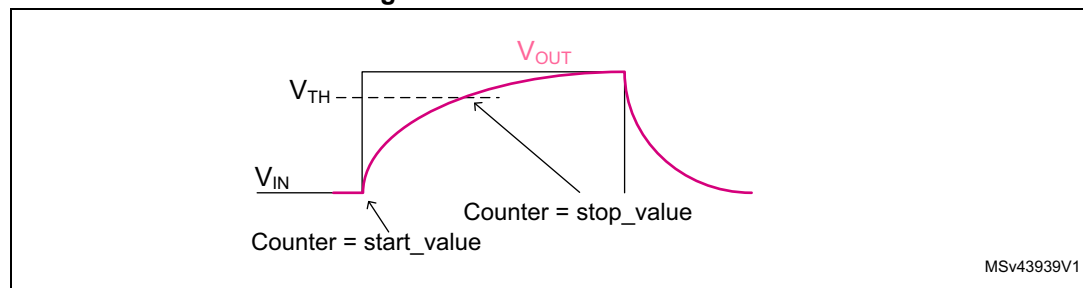

3.1.2 Oversampling

The purpose of oversampling is to provide a final measurement of the input voltage high and low levels (V_{IH} and V_{IL}) with the precision of the CPU clock.

Each successive V_{IH} or V_{IL} measurement is delayed by one CPU clock cycle in order to span all the possible values.

The number of measurements necessary to span all the values are MCU core dependent. For STM8 microcontrollers, this number is equal to 8.

Figure 6 illustrates this concept on an STM8 microcontroller.

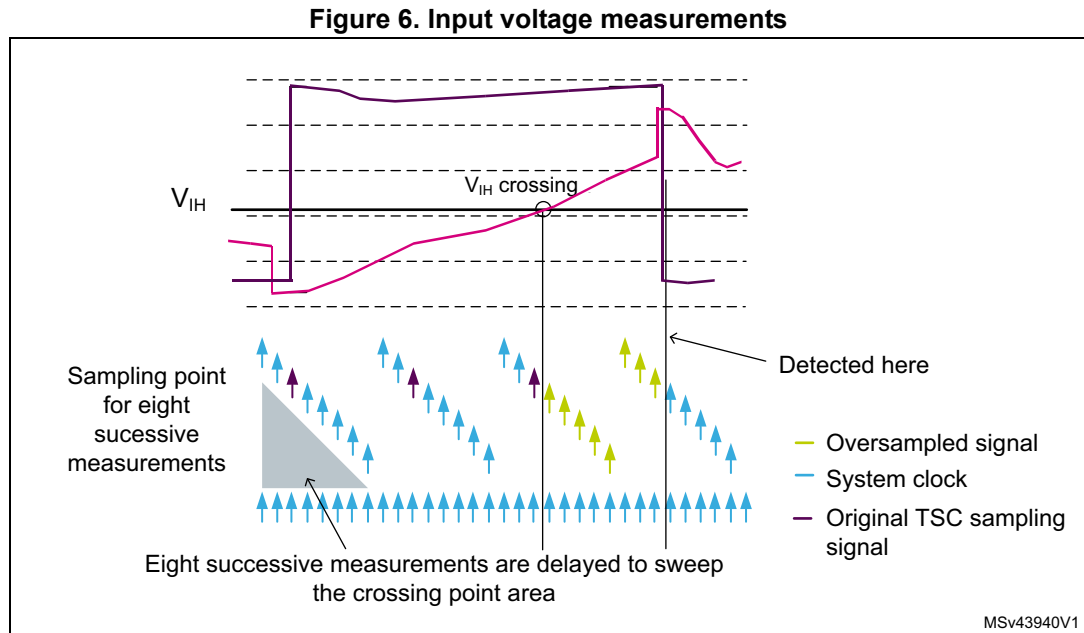

3.2 Input voltage measurement principle

In order to improve the robustness against voltage and temperature variations, two measurements are performed consecutively on the electrodes:

- one measures the capacitance charge until the V_{IH} level is reached.
- the second measures the capacitance discharge until the V_{IL} level is reached.

Figure 7 and Table 2 illustrate what happens in detail on the acquisition electrode (Acq I/O) and on the Load I/O pin.

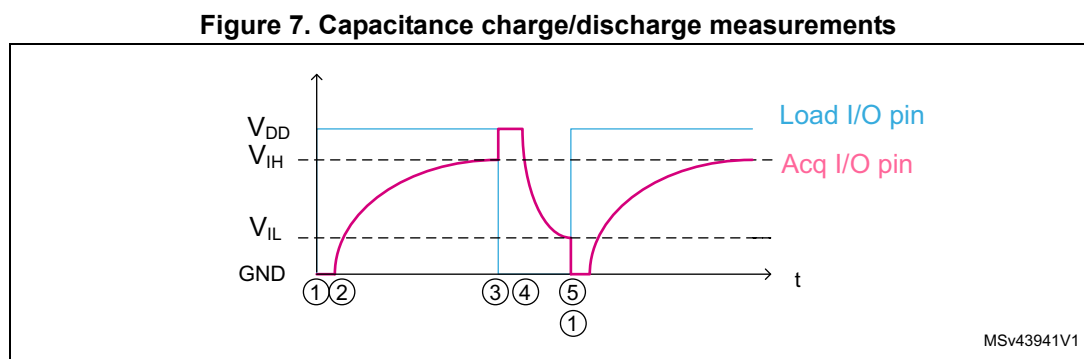

Table 2. Capacitance charge/discharge measurement steps

Step	Description
1	<ul style="list-style-type: none"> – Load I/O pin is set in Output mode at V_{DD}. – Acq I/O pin is set in Output mode at GND. – Timer counter V_{IH} start value is saved (vih_start).
2	Acq I/O pin is set in Input mode Hi-Z. --> The electrode capacitance C_X is charging.
3	After the voltage on the Acq I/O pin reaches V_{IH} : <ul style="list-style-type: none"> – Timer counter V_{IH} stop value is saved (vih_stop) and the V_{IH} measurement is calculated and saved ($vih_stop - vih_start$). – Acq I/O pin is set in Output mode at V_{DD}. – Load I/O pin is set in Output mode at GND. – Timer counter V_{IL} start value is saved (vil_start).
4	Acq I/O pin is set in Input mode Hi-Z. --> The electrode capacitance C_X is discharging.
5	After the voltage on the Acq I/O pin reaches V_{IL} : <ul style="list-style-type: none"> – Timer counter V_{IL} stop value is saved (vil_stop) and the V_{IL} measurement is calculated and saved ($vil_stop - vil_start$). – The two measurements “vih_meas” and “vil_meas” are added and saved. The process continues with Step 1.

3.3 Touch effect

The electrode shape and size, the layout from the touch controller device to the electrode (and more specifically the ground coupling) as well as the dielectric panel material and thickness are the main parameters that define the value of the electrode capacitance (C_X). As a consequence, the RC charge and discharge values are directly dependent on this C_X value. *Figure 8* illustrates this “touch effect”.

The time $\langle t1' \rangle$ (where the V_{IH} level is reached) is greater than the time $\langle t1 \rangle$. This is the same for the V_{IL} level with times $t2'$ and $t2$.

Figure 8. Touch effect example

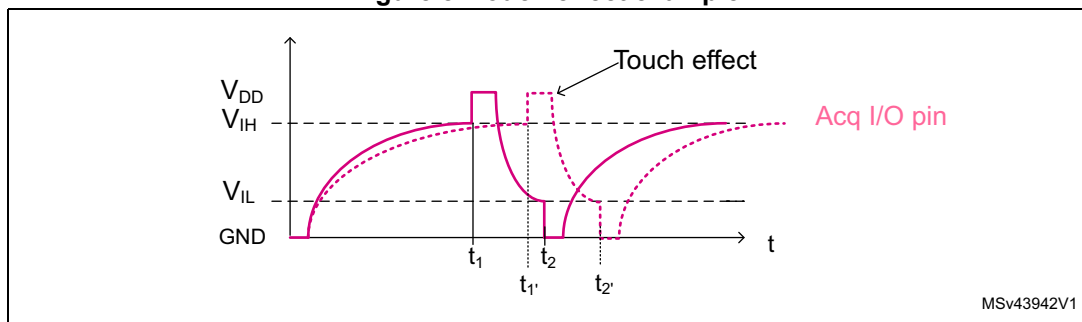

3.4 Multi acquisitions and high-frequency (HF) noise rejection

To improve the measurement accuracy and reject HF noise, it is necessary to perform these V_{IH} and V_{IL} measurements several times before determining that the key is effectively “touched”. This number of acquisitions is calculated using one of two variables:

- the first one is fixed and dependent on the MCU core
- the other one is configurable (through the configuration file of the ST touch sensing library).

For information, the number of fixed acquisitions is set to ‘8’ for STM8 devices (8 V_{IH} measurements + 8 V_{IL} measurements).

Figure 9. Types of acquisitions

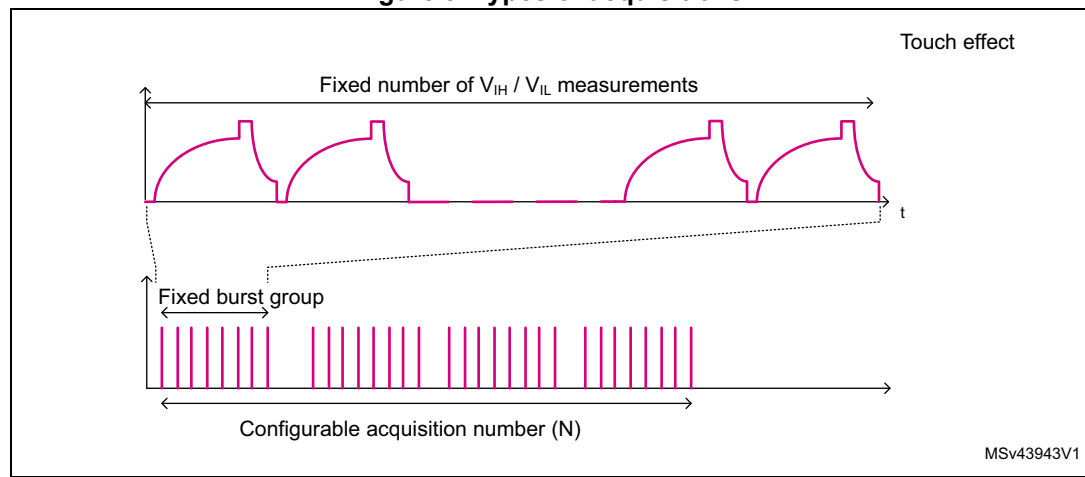

Note: The configurable acquisition number (N) can be set differently in the configuration file of the ST touch sensing library for the single-channel keys and for the multi-channel keys.

The [Figure 10](#) to [Figure 12](#) illustrate examples of HF noise rejection. If the acquisition number (N) is set to 4, a complete acquisition of one electrode consists of 4 correct “burst groups” (BGs). The word “correct” means that all measurements inside the group remain between a minimum and a maximum limit.

These examples show different scenarios depending on the level of noise. The green line means that the V_{IH}/V_{IL} measurement is correct, and the red line indicates an incorrect V_{IH}/V_{IL} measurement.

Example 1 ([Figure 10](#)): there is no noise and no measurements are rejected. All the measurements inside each burst group pass. The complete acquisition is done quickly.

Figure 10. HF noise rejection example 1

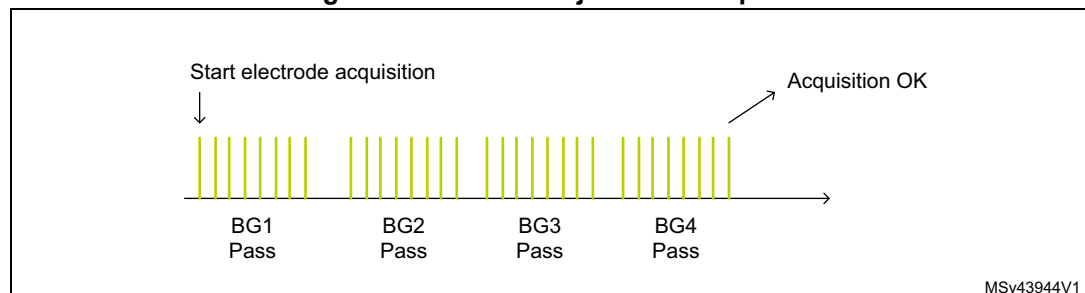

Example 2 (Figure 11): there is a small amount of noise and some measurements are rejected (i.e. r1 and r2). The burst group 3 (BG3) is repeated until all measurements within this group pass. More time is required for a complete acquisition.

Figure 11. HF noise rejection example 2

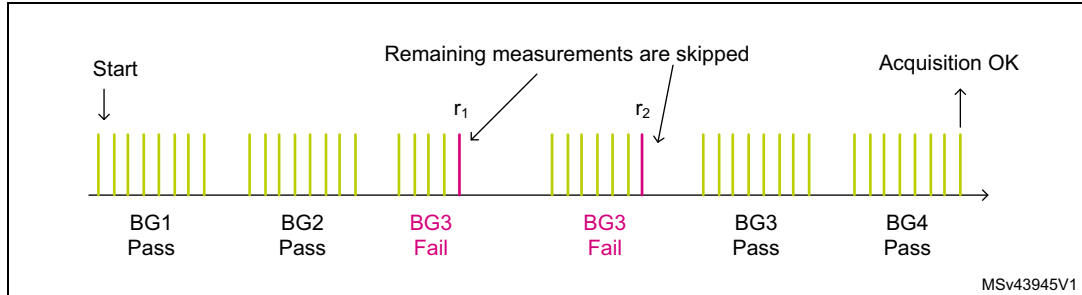

Example 3 (Figure 12): there is a lot of noise and the maximum limit (i.e. 20) is reached. In this case, the complete electrode acquisition is rejected. The maximum number of rejected measurements is reached and the acquisition is stopped on that electrode.

Figure 12. HF noise rejection example 3

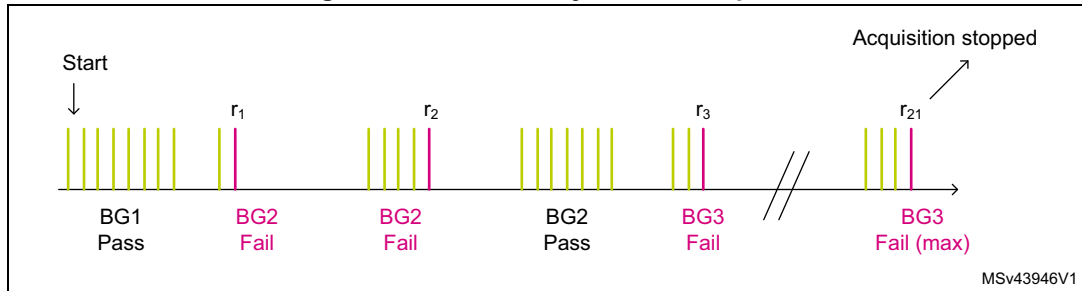

Note: The maximum number of rejected measurements is set in the configuration file of the ST touch sensing library.

Calculation of min/max limits

These min/max limits are calculated by applying a multiplication coefficient to the first V_{IH}/V_{IL} measurement of each burst group. This multiplication factor is set inside the configuration file of the ST touch sensing library. As a consequence the first V_{IH}/V_{IL} measurements of each burst group is always “Pass”. In case the first measurement is “incorrect”, and the consecutive ones are “correct”, the burst group is determined “Fail”.

4 Revision history

Table 3. Document revision history

Date	Revision	Changes
30-Jan-2009	1	Initial release.
25-Mar-2009	2	Updated title and <i>Figure 6: Input voltage measurements</i> .
23-Jan-2017	3	<ul style="list-style-type: none">– Updated title.– <i>Table 1</i> added in <i>Introduction</i>.– Updated note below <i>Figure 4: Capacitive touch sensing implementation example</i>

IMPORTANT NOTICE – PLEASE READ CAREFULLY

STMicroelectronics NV and its subsidiaries ("ST") reserve the right to make changes, corrections, enhancements, modifications, and improvements to ST products and/or to this document at any time without notice. Purchasers should obtain the latest relevant information on ST products before placing orders. ST products are sold pursuant to ST's terms and conditions of sale in place at the time of order acknowledgement.

Purchasers are solely responsible for the choice, selection, and use of ST products and ST assumes no liability for application assistance or the design of Purchasers' products.

No license, express or implied, to any intellectual property right is granted by ST herein.

Resale of ST products with provisions different from the information set forth herein shall void any warranty granted by ST for such product.

ST and the ST logo are trademarks of ST. All other product or service names are the property of their respective owners.

Information in this document supersedes and replaces information previously supplied in any prior versions of this document.

© 2017 STMicroelectronics – All rights reserved