

### How to manage simultaneous I<sup>2</sup>C and RF data transfers with the M24LRxxE-R

## Introduction

The M24LRxxE\_R is an EEPROM device designed to be accessed via two different interfaces: a wired I<sup>2</sup>C interface and a standard contactless ISO 15693 RFID interface.

**Figure 1. Typical application of an M24LRxxE\_R dual interface EEPROM**

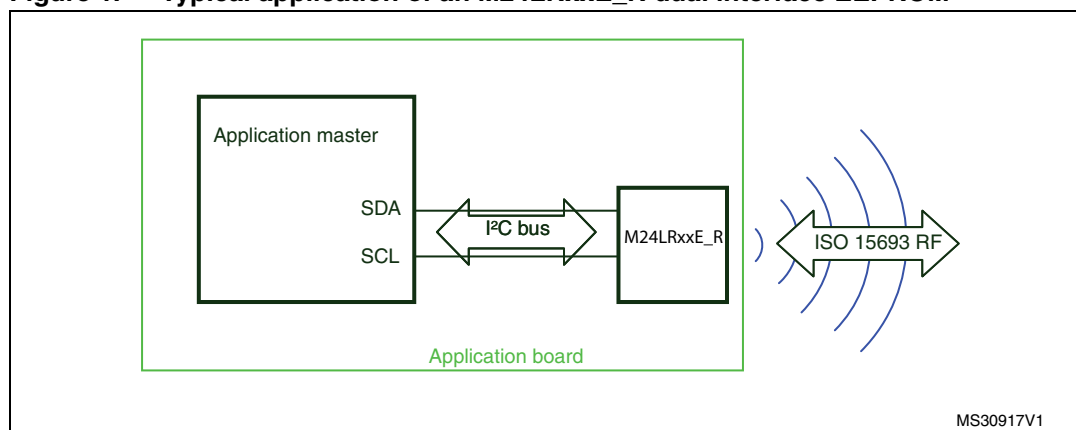

ST has published various supporting application notes explaining how the RF interface works and the basic principles of passive RFID technology. These documents are available from: [www.st.com/dualeeprom](http://www.st.com/dualeeprom).

The possibility of using two different interfaces to control the dual-interface EEPROM implies two host controllers: a microcontroller with an I<sup>2</sup>C bus and an ISO 15693 RFID reader. Due to their nature, these two host controllers are not synchronized, which means that both controllers might try to access the M24LRxxE\_R concurrently.

To manage this kind of situation, the M24LRxxE\_R has a built-in circuitry able to handle possible concurrent communications and powering activities from the RF and I<sup>2</sup>C sides.

This application note describes how the M24LRxxE\_R arbitration circuitry operates. It applies to the products listed in [Table 1](#).

**Table 1. Applicable products**

Type	Part numbers
Memory products	M24LR04E-R, M24LR16E-R, M24LR64E-R

# Contents

- 1 RF - I<sup>2</sup>C arbitration mechanism description ..... 5**
  - 1.1 Communications and power supply conditions ..... 5
  - 1.2 Communication arbitration when the RF and I<sup>2</sup>C channels are both active ..... 6
    - 1.2.1 I<sup>2</sup>C busy states ..... 6
    - 1.2.2 RF busy states ..... 6
    - 1.2.3 Arbitration ..... 8
  
- 2 Recommendations when developing the M24LRxxE\_R application software ..... 9**
  - 2.1 Issuing a command through the I<sup>2</sup>C channel ..... 9
    - 2.1.1 I<sup>2</sup>C request while the RF channel is busy ..... 9
    - 2.1.2 I<sup>2</sup>C requests and RF time slots ..... 10
    - 2.1.3 An I<sup>2</sup>C request was interrupted ..... 12
  - 2.2 Issuing a command through the RF channel ..... 13
  
- 3 Revision history ..... 14**

## List of tables

Table 1.	Applicable products .....	1
Table 2.	Four possible combinations of power supply sources .....	5
Table 3.	Possible cases of communication arbitration .....	8
Table 4.	M24LRxxE_R status according to command and $V_{CC}$ supply .....	13
Table 5.	Document revision history .....	14

# List of figures

Figure 1. Typical application of an M24LRxxE\_R dual interface EEPROM. . . . . 1

Figure 2. I<sup>2</sup>C read command busy state. . . . . 6

Figure 3. I<sup>2</sup>C write command busy state . . . . . 6

Figure 4. RF read command busy state. . . . . 6

Figure 5. RF write command busy state . . . . . 7

Figure 6. RF Stay Quiet command busy state . . . . . 7

Figure 7. Example of an Inventory command where the M24LRxxE\_R is decoded in Slot 13. . . . . 8

Figure 8. I<sup>2</sup>C polling when the RF channel is processing a command. . . . . 9

Figure 9. M24LRxxE\_R state transition diagram . . . . . 11

Figure 10. Optimal hardware schematic of an M24LRxxE\_R application . . . . . 12

# 1 RF - I<sup>2</sup>C arbitration mechanism description

The M24LRxxE\_R arbitration circuitry is twofold. It contains:

- a power management unit that handles the power coming potentially from the RF or the I<sup>2</sup>C side
- a communication arbitration unit that tackles potential concurrent communications from the RF and the I<sup>2</sup>C sides

## 1.1 Communications and power supply conditions

The power supply management unit has been designed to allow for flexibility, especially when both the RF power and the wired power line are active at the same time.

The basic principle is:

- When supplied only from the RF side:
  - the M24LRxxE\_R can be accessed only by the RF reader
- When supplied from both the V<sub>CC</sub> pin and the RF field:
  - the M24LRxxE\_R will serve the first decoded command (either RF or I<sup>2</sup>C) and will not decode any command from the other interface (either I<sup>2</sup>C or RF) until the first decoded command is complete.

**Table 2. Four possible combinations of power supply sources**

Possible cases	V <sub>CC</sub>	RF field	Actions
Case 1	0 V or not connected	Off	The M24LRxxE_R is reset.
Case 2	0 V or not connected	On	RF data transfers: yes I <sup>2</sup> C data transfers: no
Case 3	On <sup>(1)</sup>	On	RF data transfers: yes I <sup>2</sup> C data transfers: yes (see <a href="#">Section 1.2: Communication arbitration when the RF and I<sup>2</sup>C channels are both active</a> for details).
Case 4	On <sup>(1)</sup>	Off	RF data transfers: no I <sup>2</sup> C data transfers: yes

1. V<sub>CC</sub> is "On" when the value is between V<sub>CCmin</sub> and V<sub>CCmax</sub>. Please refer to the M24LRxxE\_R datasheet for full details.

## 1.2 Communication arbitration when the RF and I<sup>2</sup>C channels are both active

Arbitration depends on whether the I<sup>2</sup>C and RF channels are in the busy state. [Section 1.2.1](#) and [Section 1.2.2](#) give the definitions of the I<sup>2</sup>C and RF busy states, respectively.

### 1.2.1 I<sup>2</sup>C busy states

When decoding an I<sup>2</sup>C read command, the M24LRxxE\_R is in the I<sup>2</sup>C busy state from the Start condition until the Stop condition.

**Figure 2. I<sup>2</sup>C read command busy state**

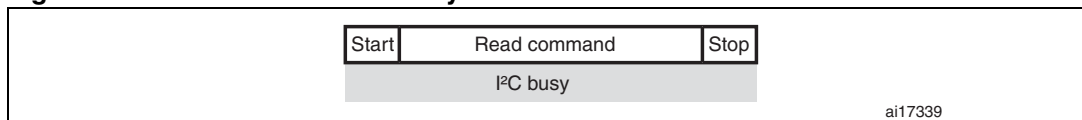

When decoding an I<sup>2</sup>C write command, the M24LRxxE\_R is in the I<sup>2</sup>C busy state from the Start condition until the completion of the write cycle (triggered by the Stop condition).

**Figure 3. I<sup>2</sup>C write command busy state**

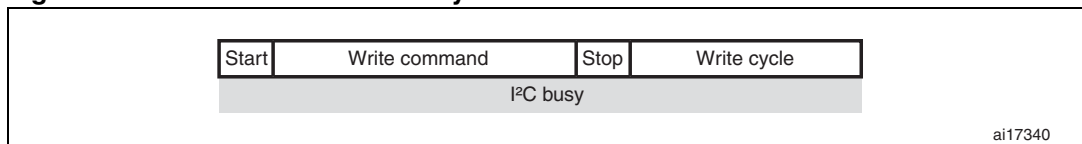

### 1.2.2 RF busy states

In most cases, an RF command is defined as a received request initiated by the SOF (start of frame) and terminated by the decoding of the EOF (end of frame) of the response frame.

RF commands can be gathered into several groups:

#### Read command group

When decoding an RF read command, the M24LRxxE\_R is in the RF busy state from the SOF (start of frame) of the request frame until the EOF (end of frame) of the response frame. The figure below shows the RF busy state of commands in the read group.

**Figure 4. RF read command busy state**

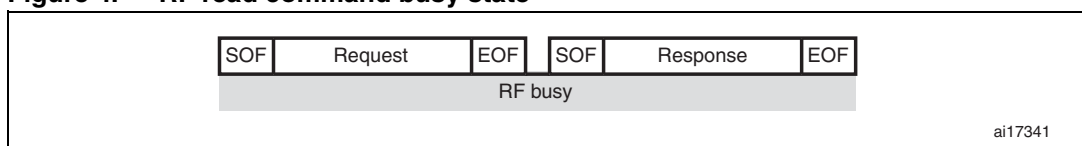

Commands in the RF read command group are:

- Read Block, Fast Read Single Block, Read Multiple Blocks, Fast Read Multiple Blocks
- Get System Info
- Select
- Reset to Ready
- Get Multiple Block Security Status
- Initiate, Fast Initiate
- Inventory Initiated

### Write command group

When decoding an RF write command, the M24LRxxE\_R is in the RF busy state from the SOF (start of frame) of the request frame until the EOF (end of frame) of the response frame. Write commands include a write cycle  $t_w$ . The figure below shows the RF busy state of commands in the write group.

**Figure 5. RF write command busy state**

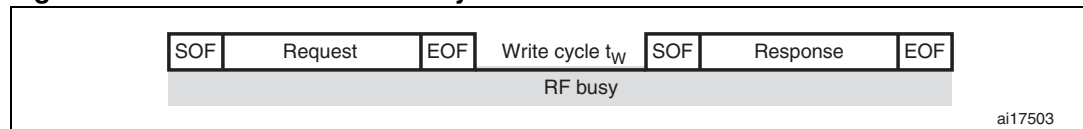

Commands in the RF write command group are:

- Write Block
- Write AFI, Lock AFI
- Write DSFID, Lock DSFID
- Write-sector Password, Lock-sector Password, Present-sector Password

### Stay Quiet command

The Stay Quiet command is the only command defined as a single request frame (not followed by a response frame). The M24LRxxE\_R is in the RF busy state during the whole [SOF .... EOF] sequence as shown in the figure below.

**Figure 6. RF Stay Quiet command busy state**

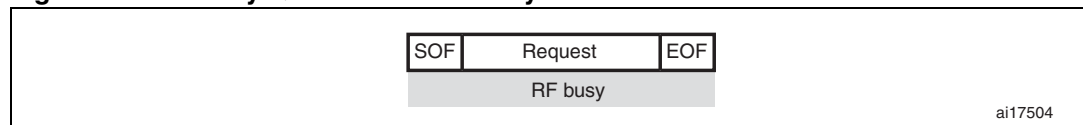

### Inventory command

An Inventory command is used when several M24LRxxE\_R devices are inside the range of the same RF electromagnetic field.

When the Inventory command scans 16 slots, the M24LRxxE\_R is in the RF busy state from the SOF (start of frame) of the request frame until the EOF (end of frame) of the response frame.

*Note: The addressed M24LRxxE\_R device might stay a long time in the RF busy state if it is decoded during the last (16<sup>th</sup>) time slot.*

**Figure 7. Example of an Inventory command where the M24LRxxE\_R is decoded in Slot 13**

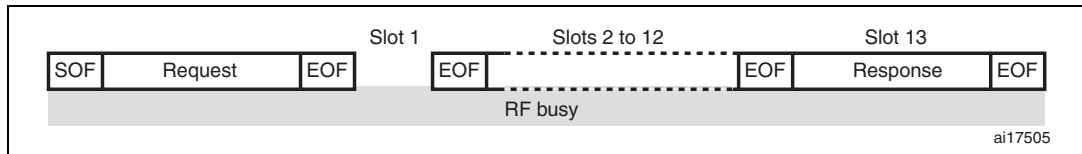

### 1.2.3 Arbitration

When both interfaces are active (as defined in Case 3 in [Table 2: Four possible combinations of power supply sources](#)<sup>1</sup>), the M24LRxxE\_R decodes and executes the first received command, as detailed in [Table 3: Possible cases of communication arbitration](#).

**Table 3. Possible cases of communication arbitration**

Initial state	Event	M24LRxxE_R action
M24LRxxE_R is in the I <sup>2</sup> C busy state: V <sub>CC</sub> active and an I <sup>2</sup> C command is being decoded or executed	RF command transmitted during an I <sup>2</sup> C command	RF command is not decoded
M24LRxxE_R is in the RF busy state: an RF command is being decoded or executed	V <sub>CC</sub> active and I <sup>2</sup> C command transmitted during an RF command	I <sup>2</sup> C command is not decoded



## 2 Recommendations when developing the M24LRxxE\_R application software

The application software has to take into account that a command might not be executed if the other channel (I<sup>2</sup>C or RF) is already processing a command. The application software should therefore check the M24LRxxE\_R busy status before sending a command.

### 2.1 Issuing a command through the I<sup>2</sup>C channel

#### 2.1.1 I<sup>2</sup>C request while the RF channel is busy

If the M24LRxxE\_R is processing a command from the RF channel, no command issued on the I<sup>2</sup>C bus will be executed, therefore none of the bytes transmitted on the I<sup>2</sup>C bus will be acknowledged (NoAck). This information can be considered as the RF busy state<sup>(a)</sup> and the application's I<sup>2</sup>C software should include a polling loop on the RF busy state (with a timeout limit) when issuing a command on the I<sup>2</sup>C bus. In this way, the I<sup>2</sup>C command can be completed once the RF command under process has completed.

**Figure 8. I<sup>2</sup>C polling when the RF channel is processing a command**

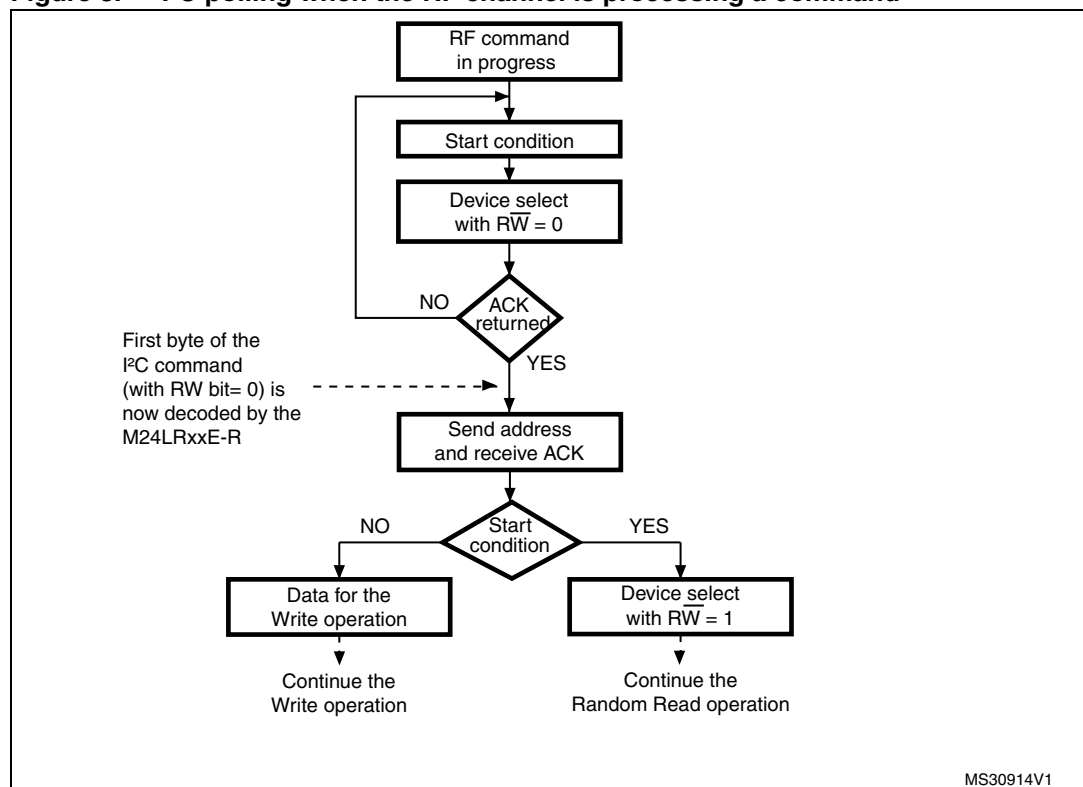

a. In the same way as during an internal write cycle, the M24LRxxE\_R is “busy” during  $t_W$  (please refer to the M24LRxxE\_R datasheet for more details about the polling loop during  $t_W$ ).

### Important

It is paramount to exactly carry out the I<sup>2</sup>C polling sequence described in [Figure 8](#) in order to keep the M24LRxxE\_R in a constant I<sup>2</sup>C busy state.

- **Right method:** once the device select is acknowledged, the I<sup>2</sup>C command starts executing until full completion, that is, until the transmission of the Stop condition which ends the command (or at the end of the write cycle  $t_{W}$ , for a write command).
- **Wrong method:** looping on the device select until it is acknowledged, sending a Stop condition and then initiating a new I<sup>2</sup>C command: this is inadequate as an RF request might have been served between [Ack] and the new I<sup>2</sup>C command (time slot during which the M24LRxxE\_R is not in the I<sup>2</sup>C busy state).

*Note:* If the application is disturbed by too great a number of decoded RF commands, it might be convenient that the I<sup>2</sup>C bus master prompts the application to stop RF requests so that the I<sup>2</sup>C bus can access the M24LRxxE\_R.

## 2.1.2 I<sup>2</sup>C requests and RF time slots

### Application software management

In most cases, the application fully controls the I<sup>2</sup>C bus. On the other hand, it cannot always predict RF commands. To have a robust application, the M24LRxxE\_R should be fully controlled through the I<sup>2</sup>C bus, that is, the application master has to:

1. determine when the I<sup>2</sup>C commands have to be transmitted
2. determine the time slots during which RF transfers may be processed

The reason for this is that RF commands might not be properly transmitted (for example, if the M24LRxxE\_R leaves the RF field). The I<sup>2</sup>C bus Master has to prevent this from happening by applying the following rules:

- The Master determines when the I<sup>2</sup>C commands have to be transmitted  
The Master delivers the supply voltage (through one of its I/Os) to the M24LRxxE\_R's V<sub>CC</sub> pin only when an I<sup>2</sup>C data transfer is under way
- The Master determines the RF time slots  
The Master stops supplying (I/O in HiZ) the M24LRxxE\_R through its V<sub>CC</sub> pin upon completion of the I<sup>2</sup>C data transfer. RF transfers are processed more safely when the V<sub>CC</sub> pin is not supplied, because:
  - If the decoded RF command is correct, it is executed (no need to supply power through the V<sub>CC</sub> pin)
  - If the RF command is truncated (M24LRxxE\_R is outside the RF field), the M24LRxxE\_R is reset (Power-off state, see [Figure 9](#)).

Figure 9. M24LRxxE\_R state transition diagram

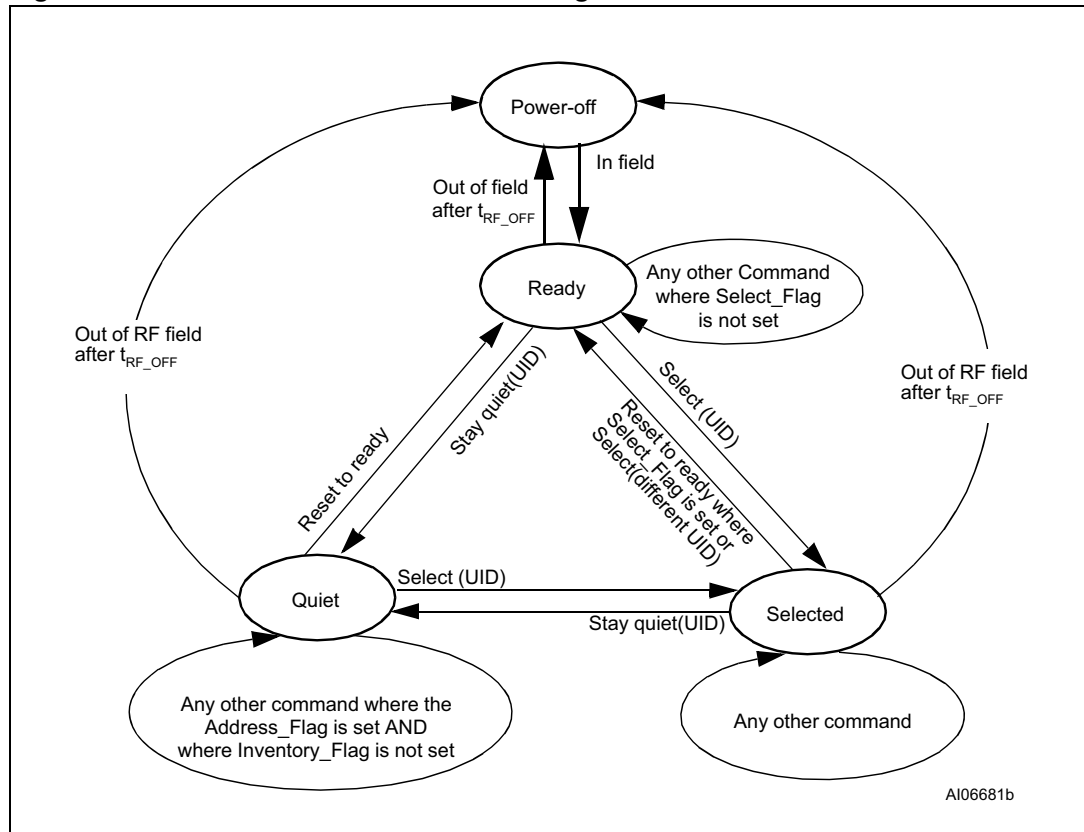

1. The M24LRxxE\_R returns to the Power Off state if the tag is out of the RF field for at least  $t_{RF\_OFF}$ .

## Application hardware architecture

The application Master should control the I<sup>2</sup>C bus lines and the power supply line so as to keep full control of the M24LRxxE\_R. *Figure 10* shows a typical hardware schematic.

**Figure 10. Optimal hardware schematic of an M24LRxxE\_R application**

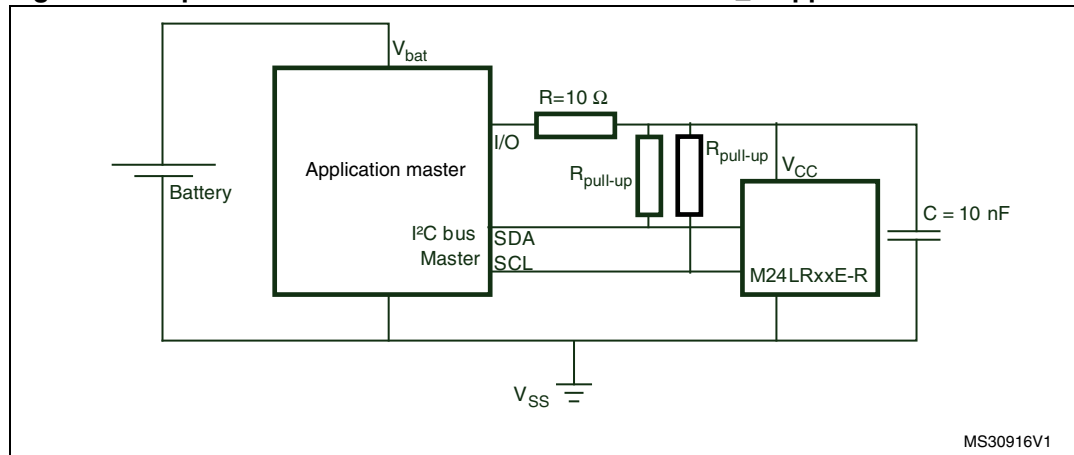

This type of hardware architecture is optimal in applications where power saving is a key feature (like portable applications supplied from a battery). The supply voltage can be directly delivered to an ultralow power microcontroller (for instance the STM8L, information available from <http://www.st.com/mcu/>). This implementation makes it possible to keep the application supply current in the 1  $\mu$ A range (value of the STM8L supply current when in the Active-Alt mode) and:

- the application saves power when in the Standby mode, as the battery does not supply the standby current to the M24LRxxE\_R (40  $\mu$ A) nor the current through the SDA pull-up resistor
- the application controls the M24LRxxE\_R in a safe mode (the V<sub>CC</sub> pin is supplied by the Master only when an I<sup>2</sup>C request is being processed)

### 2.1.3 An I<sup>2</sup>C request was interrupted

A Start condition defines the I<sup>2</sup>C channel as busy until the completion of the I<sup>2</sup>C command (Stop condition) or until I<sup>2</sup>C timeout. If for some uncontrolled reason, inadvertent unterminated instructions are sent to the I<sup>2</sup>C bus, the M24LRxxE-R features a timeout mechanism that automatically resets the I<sup>2</sup>C logic block.

The I<sup>2</sup>C busy state is reset either:

- by decoding a device select byte different from 1010 XXXXb,
- by decoding a Stop condition,
- by the completion of the internal write cycle ( $t_{w}$ , triggered by a decoded write instruction), or
- after timeout.

The best way for the I<sup>2</sup>C bus Master to clear a spurious busy state is to periodically issue a [Start+Stop] sequence.

*Note:* In noisy applications, ST recommends to implement the “9 Start + 1 Stop” sequence described in AN1471 (available from the ST website: [www.st.com](http://www.st.com)).

## 2.2 Issuing a command through the RF channel

### Case 1: the M24LRxxE\_R is processing an I<sup>2</sup>C command

If the M24LRxxE\_R is processing a command from the I<sup>2</sup>C channel, no command issued on the RF channel will be executed (the RF command will not provide any response) when the M24LRxxE\_R is I<sup>2</sup>C busy.

The application's RF software should include an "I<sup>2</sup>C busy polling loop" (including a timeout as there might not be a response) when issuing an RF command. In this way, the RF command is always correctly executed once the I<sup>2</sup>C commands under execution are completed.

### Case 2: the M24LRxxE\_R application is powered on

The first condition for a safe design of an M24LRxxE\_R application is that all the sensitive data stored in the M24LRxxE\_R memory are protected with RF passwords, so that a spurious RF command could not modify these data.

The second condition for a safe application design is that the application Master fully controls the M24LRxxE\_R. We know that, as explained in [Section 2.1.2](#), if the V<sub>CC</sub> pin is not supplied, and the RF field drops to zero while the M24LRxxE\_R is decoding an RF command, then the M24LRxxE\_R is reset. This means that the Master has to supply the M24LRxxE\_R's V<sub>CC</sub> pin only during an I<sup>2</sup>C transfer, and leave the V<sub>CC</sub> pin floating the rest of the time (see [Figure 10](#)).

Depending on the application's RF data transfer flow, it might also be wise to add a third level of safety:

- once an RF session (several commands) is completed, blindly send a Write-sector Password command with a wrong password value: this will set the internal flag defining the status of the presented password (flag set as "wrong password presented").

### Case 3: the M24LRxxE\_R application is not powered

This is the typical case where the application is packed in a box (at the end of the production line) and the data update is performed through RF.

The only condition for a safe application design is that the sensitive data stored in the M24LRxxE\_R memory are protected with RF passwords, so that a spurious RF command could not modify these data.

**Table 4. M24LRxxE\_R status according to command and V<sub>CC</sub> supply**

Command processed by the M24LRxxE_R	V <sub>CC</sub> pin status	Device status
I <sup>2</sup> C command	V <sub>CC</sub> supplied	I <sup>2</sup> C busy state
RF command	V <sub>CC</sub> supplied or V <sub>CC</sub> = high impedance	The M24LRxxE_R is fully dedicated to RF commands

### 3 Revision history

**Table 5. Document revision history**

Date	Revision	Changes
15-Jun-2012	1	Initial release.

**Please Read Carefully:**

Information in this document is provided solely in connection with ST products. STMicroelectronics NV and its subsidiaries ("ST") reserve the right to make changes, corrections, modifications or improvements, to this document, and the products and services described herein at any time, without notice.

All ST products are sold pursuant to ST's terms and conditions of sale.

Purchasers are solely responsible for the choice, selection and use of the ST products and services described herein, and ST assumes no liability whatsoever relating to the choice, selection or use of the ST products and services described herein.

No license, express or implied, by estoppel or otherwise, to any intellectual property rights is granted under this document. If any part of this document refers to any third party products or services it shall not be deemed a license grant by ST for the use of such third party products or services, or any intellectual property contained therein or considered as a warranty covering the use in any manner whatsoever of such third party products or services or any intellectual property contained therein.

**UNLESS OTHERWISE SET FORTH IN ST'S TERMS AND CONDITIONS OF SALE ST DISCLAIMS ANY EXPRESS OR IMPLIED WARRANTY WITH RESPECT TO THE USE AND/OR SALE OF ST PRODUCTS INCLUDING WITHOUT LIMITATION IMPLIED WARRANTIES OF MERCHANTABILITY, FITNESS FOR A PARTICULAR PURPOSE (AND THEIR EQUIVALENTS UNDER THE LAWS OF ANY JURISDICTION), OR INFRINGEMENT OF ANY PATENT, COPYRIGHT OR OTHER INTELLECTUAL PROPERTY RIGHT.**

**UNLESS EXPRESSLY APPROVED IN WRITING BY TWO AUTHORIZED ST REPRESENTATIVES, ST PRODUCTS ARE NOT RECOMMENDED, AUTHORIZED OR WARRANTED FOR USE IN MILITARY, AIR CRAFT, SPACE, LIFE SAVING, OR LIFE SUSTAINING APPLICATIONS, NOR IN PRODUCTS OR SYSTEMS WHERE FAILURE OR MALFUNCTION MAY RESULT IN PERSONAL INJURY, DEATH, OR SEVERE PROPERTY OR ENVIRONMENTAL DAMAGE. ST PRODUCTS WHICH ARE NOT SPECIFIED AS "AUTOMOTIVE GRADE" MAY ONLY BE USED IN AUTOMOTIVE APPLICATIONS AT USER'S OWN RISK.**

Resale of ST products with provisions different from the statements and/or technical features set forth in this document shall immediately void any warranty granted by ST for the ST product or service described herein and shall not create or extend in any manner whatsoever, any liability of ST.

ST and the ST logo are trademarks or registered trademarks of ST in various countries.

Information in this document supersedes and replaces all information previously supplied.

The ST logo is a registered trademark of STMicroelectronics. All other names are the property of their respective owners.

© 2012 STMicroelectronics - All rights reserved

STMicroelectronics group of companies

Australia - Belgium - Brazil - Canada - China - Czech Republic - Finland - France - Germany - Hong Kong - India - Israel - Italy - Japan - Malaysia - Malta - Morocco - Philippines - Singapore - Spain - Sweden - Switzerland - United Kingdom - United States of America

[www.st.com](http://www.st.com)

