

---

**Calculation of turn-off power losses generated by an ultrafast diode**

---

**Introduction**

This application note explains how to calculate turn-off power losses generated by an ultrafast diode, by taking into account the recovery parameters and their temperature dependency. Such losses appear when the diode changes from the forward conduction phase to the reverse conduction phase.

Furthermore, in many power supplies (DC-DC or AC-DC), in order to ensure current continuity, a rectification or freewheeling diode is often associated to a MOSFET or an IGBT. In cases where the converter is working in continuous conduction mode (CCM) with hard switching conditions, the turn-on losses in the MOSFET (or the IGBT) are usually the main contributor to the efficiency drop, due to the recovery parameters of the diode.

This application note provides methods to calculate the diode turn-off power losses in two common cases:

- Turn-off power losses generated by a diode working in rectifying mode (power losses in the switching diode and power losses in the snubber resistor due to the diode)
- Switching power losses generated by the reverse recovery current of an ultrafast diode in a switching cell (diode + MOSFET or IGBT)

The diodes discussed are all STMicroelectronics ultrafast diodes from 200 V to 1600 V.

---

## Contents

<b>1</b>	<b>Diode turn-off characteristics.....</b>	<b>3</b>
1.1	Reverse recovery waveform and associated parameters .....	3
1.2	Turn-off parameters and temperature dependency .....	7
<b>2</b>	<b>Turn-off power losses calculation.....</b>	<b>9</b>
2.1	Calculation in rectifying mode .....	9
2.1.1	Turn-off power losses generated by the diode in a simple rectifying circuit .....	9
2.1.2	Snubber power losses due to the reverse recovery current of the diode .....	10
2.2	Calculation in a switching cell (hard switching conditions) .....	11
2.2.1	Turn-off power losses generated by the diode: calculation from ideal waveforms .....	11
2.2.2	Turn-off power losses generated by the diode: calculation from real waveforms .....	13
2.2.3	Calculation based on energy measurements .....	16
<b>3</b>	<b>Conclusion.....</b>	<b>19</b>
<b>4</b>	<b>Revision history .....</b>	<b>19</b>

# 1 Diode turn-off characteristics

## 1.1 Reverse recovery waveform and associated parameters

The turn-off power losses in a diode appear when the diode switches from a forward conduction phase to a reverse conduction phase, as illustrated in the figure below:

Figure 1: Current and voltage waveforms of a diode during turn-off phase

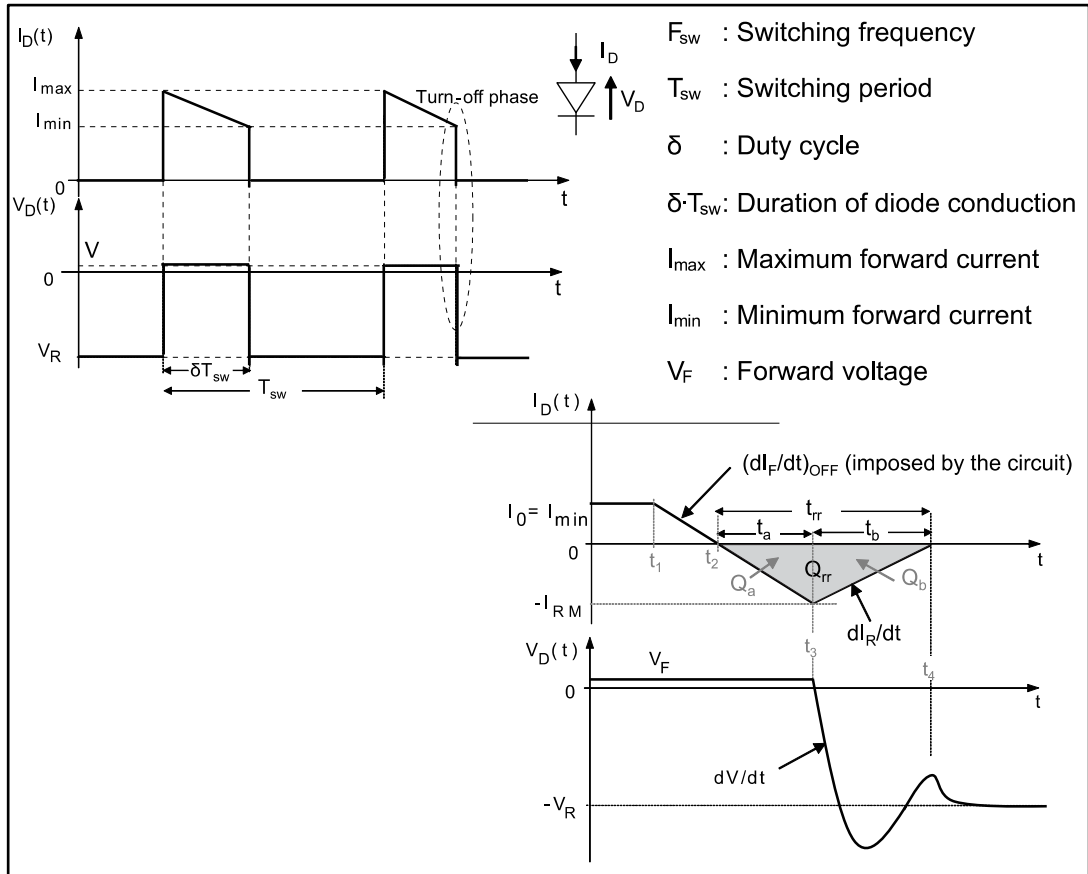

At  $t = t_1$ , the diode turns off and the current decreases with a slope  $dI_F/dt$  imposed by the circuit. Meanwhile, the diode voltage remains equal to  $V_F$  (by neglecting the parasitic inductor effect). When the current reaches zero, the charges stored during the conduction phase begin to recombine and the diode voltage is still equal to  $V_F$  during time  $t_a$  until the current reaches a negative value called  $I_{RM}$  (maximum reverse current). At that time, the diode voltage starts to decrease while the minority carriers are evacuating. The charges continue to be evacuated during time  $t_b$  with a slope  $dI_R/dt$  depending on the technology of the diode and the circuit. During this time interval ( $t_b$ ), the voltage oscillates around the reverse voltage  $V_R$  value before stabilizing. After  $t_b$ , the diode can be considered completely turned off.

The high value of  $dI_F/dt$  combined with some parasitic inductors are usually origins of overvoltage and oscillations in the circuit, which can be critical.

The reverse recovery charges, called  $Q_{rr}$ , are defined as the integral of the current flowing through the diode during a time interval  $t_2$ - $t_4$ :

$$Q_{rr} = \int_{t_2}^{t_4} I_D(t). dt \text{ Equation 1}$$

The reverse recovery time, called  $t_{rr}$ , is defined as the sum of times  $t_a$  and  $t_b$ :

$$t_{rr} = t_a + t_b \text{ Equation 2}$$

The recovery charges are also defined as equal to the sum of  $Q_a$  (the recovery charges during  $t_a$ ) and  $Q_b$  (the recovery charges during  $t_b$ ):

$$Q_{rr} = Q_a + Q_b$$

$Q_{rr}$  and  $t_{rr}$  characterize the rapidity of the diode and are used to distinguish the different designations of diodes (fast, ultrafast and hyperfast diodes).

The recovery charges  $Q_{rr}$ , the recovery current  $I_{RM}$  and the recovery time  $t_{rr}$ , are intrinsic parameters of the diode during its turn-off phase. They depend on:

- $I_F$ : Forward current flowing through the diode before it turns off
- $dI_F/dt$ : Slope applied to the diode and imposed by the circuit
- $T_j$ : Operating junction temperature of the diode
- $V_R$ : Reverse voltage applied across the diode

In most ST ultrafast diode datasheets, the curves of  $I_{RM}$ ,  $t_{rr}$  and  $Q_{rr}$  versus  $dI_F/dt$  are provided for specific values of the forward current  $I_F$  (respectively in [Figure 2: "STTH8R06  \$I\_{RM}\$  versus  \$dI\_F/dt\$ "](#), [Figure 3: "STTH8R06  \$t\_{rr}\$  versus  \$dI\_F/dt\$ "](#) and [Figure 4: "STTH8R06  \$Q\_{rr}\$  versus  \$dI\_F/dt\$ "](#)). In these figures, the reverse voltage  $V_R$  across the diode and the junction temperature  $T_j$  are fixed.

Figure 2: STTH8R06  $I_{RM}$  versus  $di_F/dt$

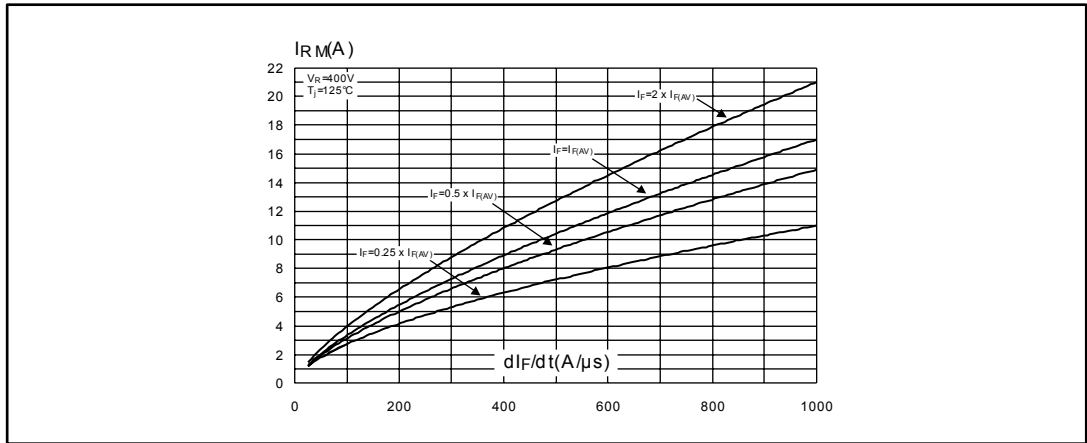

Figure 3: STTH8R06  $t_{rr}$  versus  $di_F/dt$

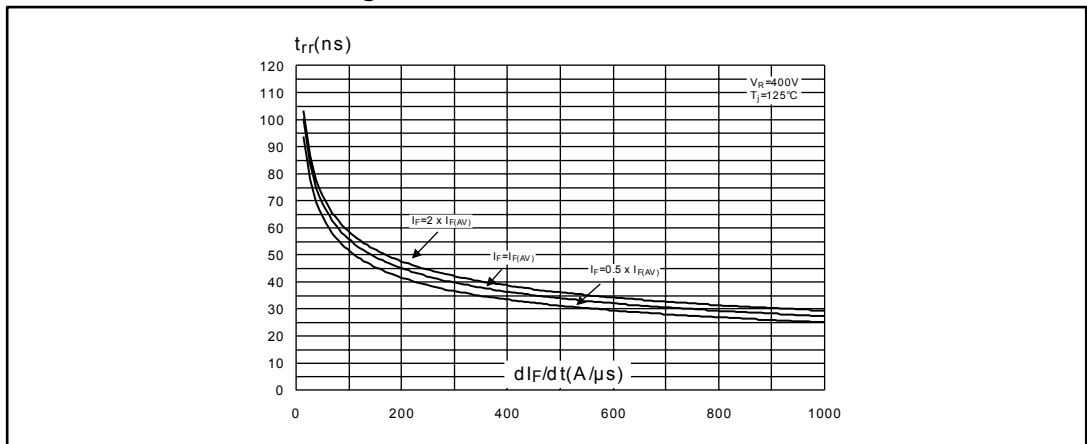
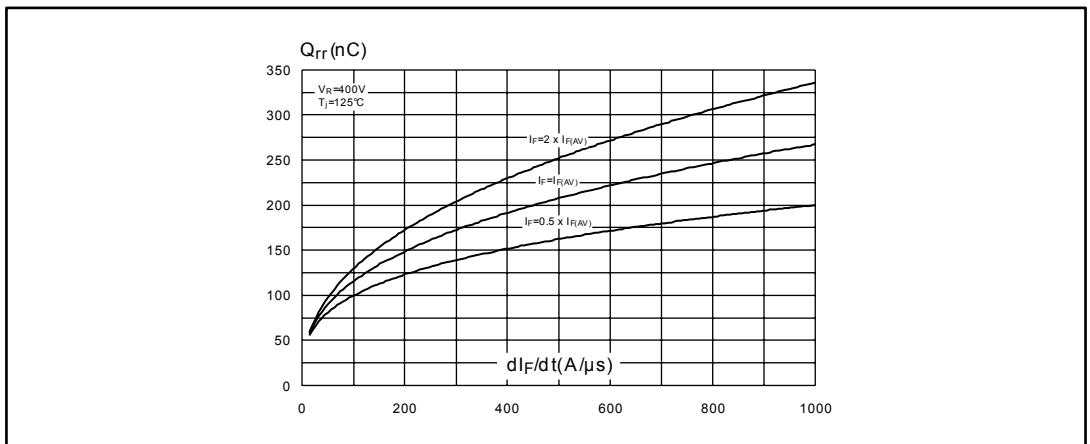

Figure 4: STTH8R06  $Q_{rr}$  versus  $di_F/dt$



As shown in the graphs above, the  $I_{RM}$ ,  $t_{rr}$  and  $Q_{rr}$  parameters are highly dependent on the  $di_F/dt$  slope.

The S factor parameter (also denoted as S) is defined as the ratio between the times  $t_b$  and  $t_a$ :

$$S = \frac{t_b}{t_a}$$

The S factor parameter is used as a metric to define how soft a diode is. Usually, a snap-off diode has  $S < 1$ , while a soft diode has  $S > 1$ . In most ST ultrafast diode datasheets, an S factor versus  $dI_F/dt$  curve is provided, as the one shown in [Figure 5: "STTH8R06 S factor versus  \$dI\_F/dt\$ "](#) for the STTH8R06 diode.

Figure 5: STTH8R06 S factor versus  $dI_F/dt$

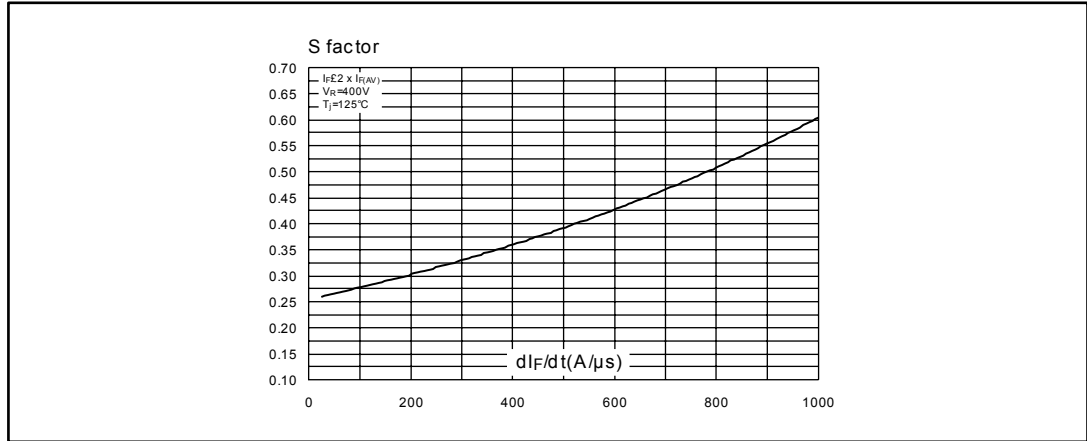

There is a relation between the S factor and  $t_{rr}$ :

$$t_{rr} = t_a + t_b$$

with  $t_a = \frac{I_{RM}}{dI_F/dt}$  and  $t_b = t_a \times S \Rightarrow t_{rr} = \frac{I_{RM}}{dI_F/dt} (1 + S)$  Equation 3

The S factor parameter should be used carefully. It is heavily dependent on the circuit environment (the switch, for example). Indeed, if the switch is changed, the S factor value, measured in the same conditions, can change also. Furthermore, when speaking of the softness factor, some people prefer to consider the slope currents ratio:  $\frac{dI_F/dt}{dI_R/dt}$

To provide best workable results with good accuracy, the switching parameters above are measured in different ways based on the recovery behavior of the diode (snap-off or soft).

Figure 6: Snap-off behavior (left) and soft behavior (right)

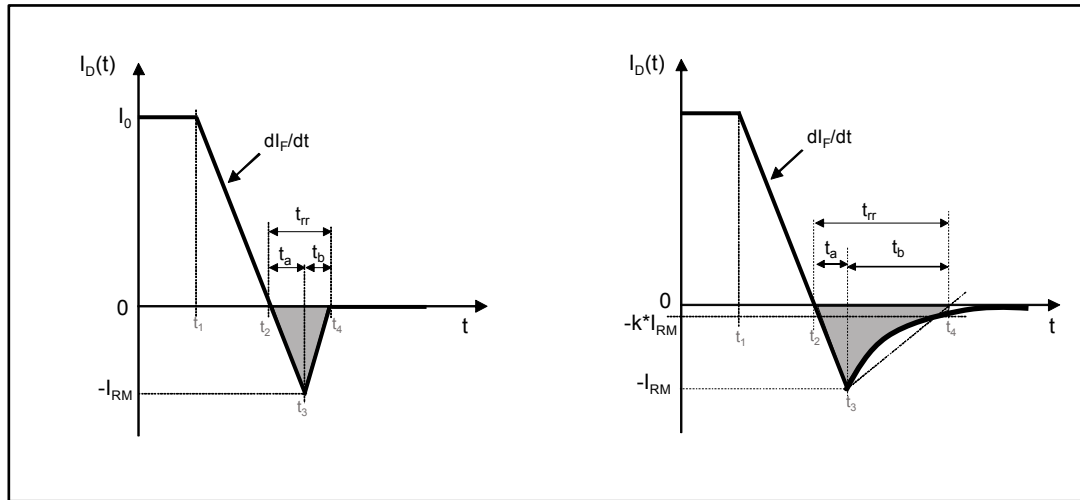

For diodes with snap-off behavior, the  $t_{rr}$  parameter is measured between  $t_2$  and  $t_4$ . With soft diodes,  $t_4$  is taken as the time where  $I_D(t) = -k \times I_{RM}$  with  $k$  usually equal to 0.25, unless specified in the datasheet. In some applications, the choice between snap-off and soft diodes can be crucial because this will correspond to a trade-off between a reduction of switching power losses and better EMI performance. For instance, in a bridge leg configuration (such as inverter topologies) the use of a soft diode is preferred in order to avoid dramatic cross-conduction.

## 1.2 Turn-off parameters and temperature dependency

Switching parameters depend on the junction temperature  $T_j$  of the diode. The datasheet curve extract below shows the variation of each parameter versus  $T_j$ . The vertical axis is the ratio between the parameter at a given  $T_j$  and the parameter value at 125 °C, chosen as a reference. For instance, for the  $Q_{rr}$  curve:

$$\frac{Q_{rr}(T_j)}{Q_{rr}(125^\circ\text{C})} = k (k \text{ is a constant})$$

Figure 7: Turn-off parameters versus junction temperature  $T_j$

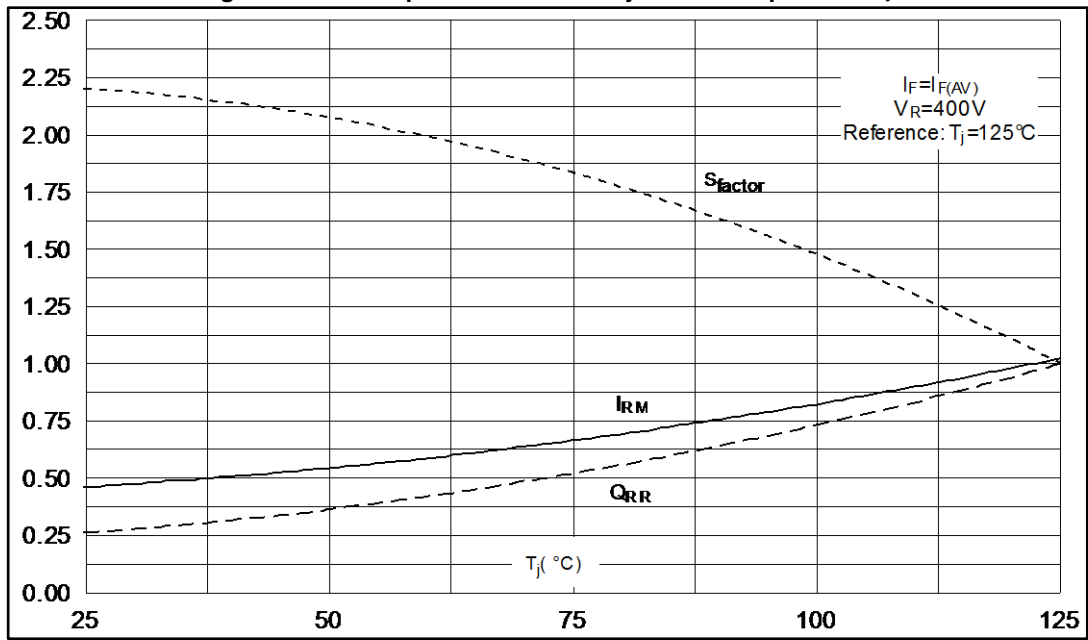

For example, to calculate the  $Q_{rr}$  at 75 °C, we first use the  $Q_{rr}$  versus  $dI_F/dt$  curve (Figure 4: "STTH8R06 Qrr versus  $dI_F/dt$ ") in order to evaluate the  $Q_{rr}$  at 125 °C for a given  $dI_F/dt$ .

Then we proceed as follows:

$$\frac{Q_{rr}(75^{\circ}C)}{Q_{rr}(125^{\circ}C)} = 0.53 \text{ (in Figure 7: "Turn-off parameters versus junction temperature } T_j\text{")}$$

$$\rightarrow Q_{rr}(75^{\circ}C) = Q_{rr}(125^{\circ}C) \times 0.53$$

with  $Q_{rr}(125^{\circ}C) = 150nC$  (in Figure 4: "STTH8R06 Qrr versus  $dI_F/dt$ ")

- $dI_F/dt = 200A/\mu s$
- $T_j = 125^{\circ}C$
- $V_R = 400V$
- $I_F = I_{F(AV)}$   
 $\rightarrow Q_{rr}(75^{\circ}C) = 150nC \times 0.53 = 79.5nC$



## 2 Turn-off power losses calculation

The power losses calculation can be helpful for designers to:

- Estimate the total power losses generated inside a diode, in order to evaluate its junction temperature.
- Estimate the total power losses generated by different diodes (in snubber circuits, power transistors, etc.) in order to select one that provides the highest efficiency for a converter.

The general turn-off power losses expression is the average of dissipated power in the diode during its turn-off phase:

$$P_{SW_{off}} = \frac{1}{T_{sw}} \int_{t_1}^{t_4} v_D(t) i_D(t) dt \quad \text{Equation 4}$$

The voltage waveform during the turn-off phase and the associated  $dV/dt$  are application dependent. The switches used in the circuit also influence the measurement of diode performance. Consequently, the voltage waveform during the switching phase can be different from one switch to another. That's why ST recommends measuring the voltage and current flowing through the diode during the turn-off phase, and using the energy measurement to accurately calculate the turn-off power losses.

Throughout this section, formulas are given to estimate power losses, with the support of the datasheet parameters, without performing any measurements. They depend on the configuration of the circuit (rectifying diode, freewheeling diode, snubber diode, etc.).

### 2.1 Calculation in rectifying mode

In rectifying mode, the  $dI_F/dt$  value is fixed by the leakage inductor of the transformer, called  $L_l$ .

#### 2.1.1 Turn-off power losses generated by the diode in a simple rectifying circuit

In the figure below, an example of a forward converter is considered with its equivalent circuit at the turn-off phase.

**Figure 8: Forward topology converter and its equivalent circuit at diode turn-off phase**

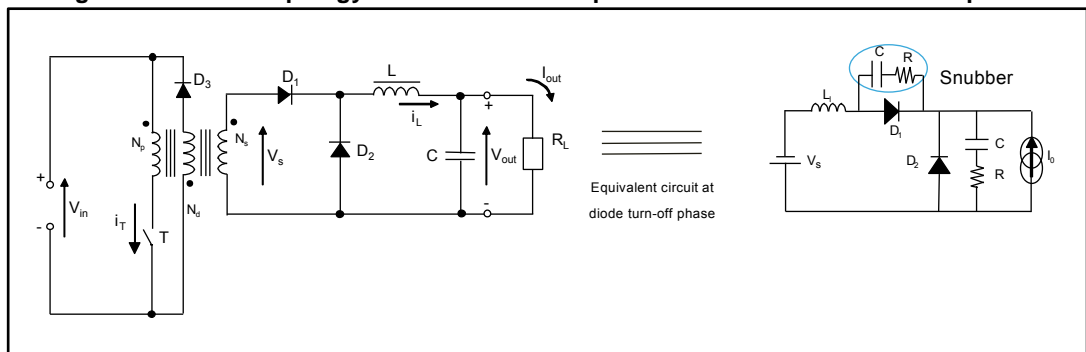

The ideal current and voltage waveforms during D1 turn-off phase is given in the graph below:

Figure 9: Ideal current and voltage waveforms of a rectifying diode during its turn-off phase

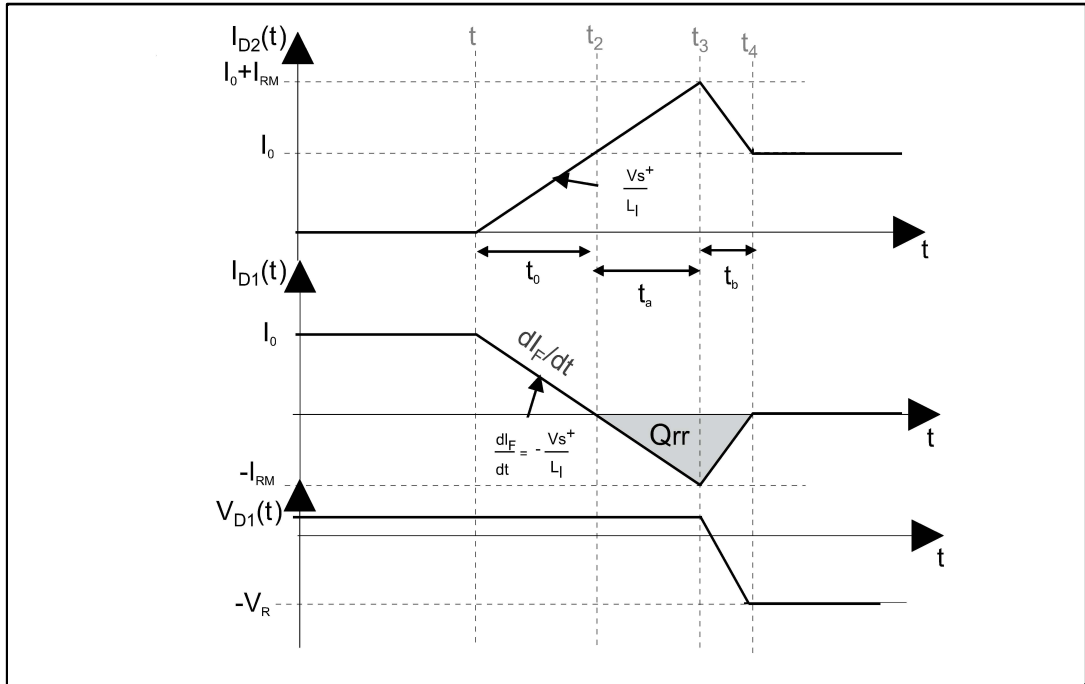

From Equation 4 and ideal waveforms above Figure 9: "Ideal current and voltage waveforms of a rectifying diode during its turn-off phase", the diode turn-off power losses in simple rectifying mode is given by:

$$P_{SW_{off}} = F_{sw} \times \left( \frac{V_{R_{RM}}^2 S}{6 dl_F/dt} \right) = \frac{F_{sw} V_R Q_b}{3} \text{ Equation 5}$$

### 2.1.2 Snubber power losses due to the reverse recovery current of the diode

A snubber circuit is used to absorb the overvoltage that occurs during each switching phase. It is usually composed of a capacitor and a resistor connected in series. The previous Figure 8: "Forward topology converter and its equivalent circuit at diode turn-off phase" shows a diode with its snubber circuit (resistor and capacitor cell).

When the diode turns off, an energy equal to:  $\frac{1}{2} L_l I_{RM}^2$  is stored in the leakage inductor  $L_l$ .

The total dissipated energy in the snubber (in the resistor) is given by:

$$E_{snubber} = \frac{1}{2} L_l I_{RM}^2 + C V_S^2 \text{ Equation 6}$$

The second part of the formula  $C V_S^2$  not being generated by the diode, the power losses caused by the diode are given by:

$$P_{Snubber_{duetodiode}} = \frac{1}{2} L_l I_{RM}^2 F_{sw} \text{ Equation 7}$$

It is very important to take the snubber losses into account, especially in high power applications where a high snubber value can be used.

## 2.2 Calculation in a switching cell (hard switching conditions)

The circuit given in *Figure 10: "Freewheeling diode in a basic switching cell"* is the typical cell of a freewheeling diode function found in buck, boost and inverter topologies. It is usually used to characterize diode switching parameters like  $I_{RM}$ ,  $t_{rr}$ ,  $Q_{rr}$ , etc. In this configuration, the  $dI_F/dt$  parameter is fixed by the speed of the switch (MOSFET Q, in the case below).

Figure 10: Freewheeling diode in a basic switching cell

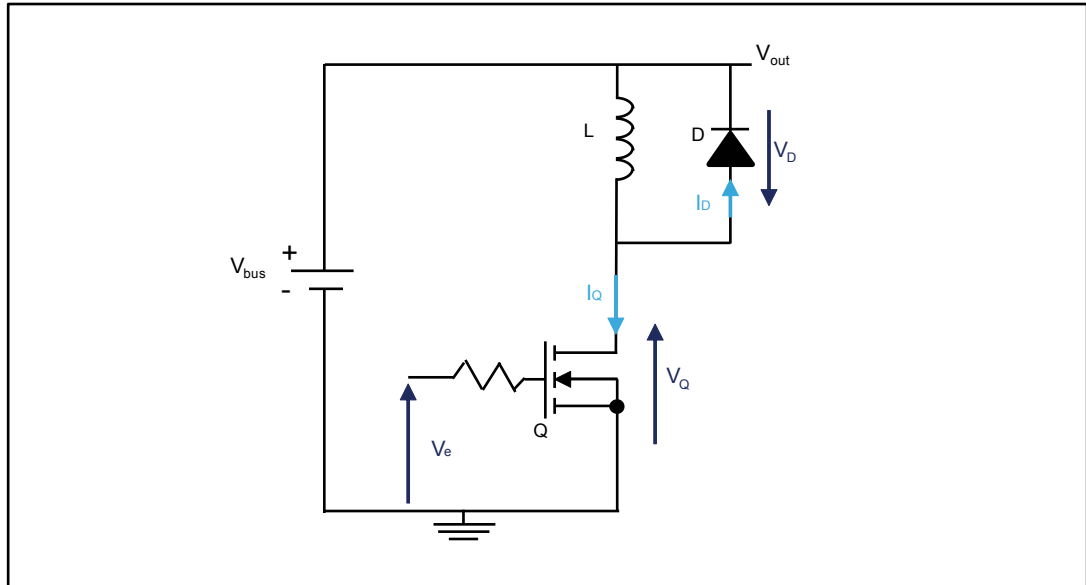

The reverse recovery current of the diode is the cause of the turn-off power losses in the diode. It is also the origin of additional power losses in the associated MOSFET during its turn-on phase.

### 2.2.1 Turn-off power losses generated by the diode: calculation from ideal waveforms

During the MOSFET turn-on phase, the gate voltage reaches a level that causes an increase of the MOSFET current and a decrease of the diode current. We call  $t_0$  the time during which the diode current decreases until the zero value is reached (between  $t_1$  and  $t_2$ ). Then comes the time required for the diode current to decrease to the maximum reverse current  $I_{RM}$ , called  $t_a$  (between  $t_2$  and  $t_3$ ). Meanwhile, the MOSFET current continues rising until it achieves the value  $I_0 = I_{RM}$ .  $t_b$  is defined as the time between the current  $I_{RM}$  ( $t_3$ ) and the time that the diode current goes back to zero ( $t_4$ ). Whereas the time during which the MOSFET voltage decreases from  $V_{out}$  to zero is called  $t_b'$ .

Figure 11: Ideal current and voltage waveforms of a switching cell during MOSFET turn-on and diode turn-off phase

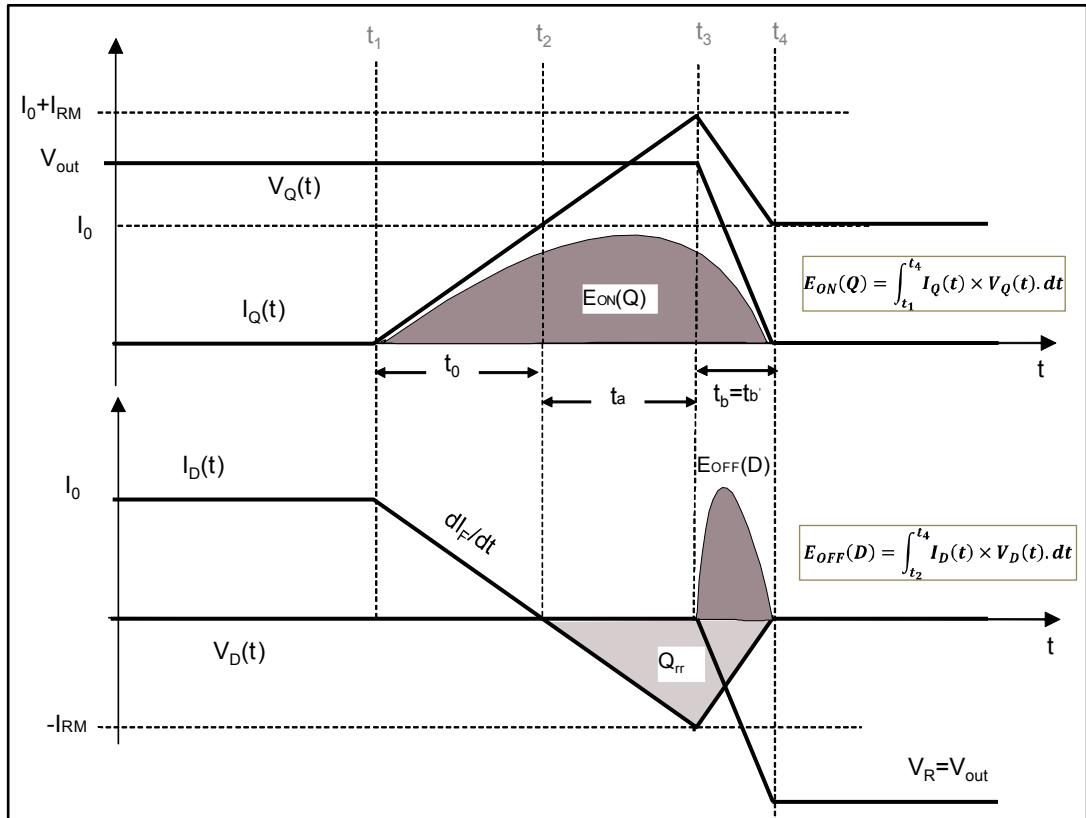

From the phenomenon described above, the recovery current of the diode introduces some additional switching losses in the MOSFET.

The approximations of this model are:

- $\frac{dI_F}{dt} = -\frac{dI_Q}{dt}$  is constant
- $t_b' = t_b$  (This is a specific case: the reverse voltage across the diode reaches  $V_{out}$  and in the meantime the recombination of minority charges stored in the diode is completed.)
- $\frac{dV_Q}{dt} = -\frac{dV_D}{dt}$  is constant
- Parasitic inductance  $L_i$  is neglected

The following power losses are calculated considering the ideal waveforms and the power definition given in [Figure 11: "Ideal current and voltage waveforms of a switching cell during MOSFET turn-on and diode turn-off phase"](#).

- MOSFET turn-on power losses between  $t_1$  and  $t_3$  are (with  $P_{SWOFF(diode)}|_{[t_1-t_3]} = 0$ ):

$$P_{SWON(MOSFET)total[t_1-t_3]} = F_{sw} V_{out} \left( \frac{1}{2} I_0 t_0 \right) + F_{sw} V_{out} \left( \frac{I_0 I_{RM}}{\frac{dI_F}{dt}} + Q_a \right) \text{ Equation 8}$$

Losses independent of the diode / Losses due to the diode

- MOSFET turn-on power losses and diode turn-off power losses between  $t_3$  and  $t_4$  are:

$$P_{SWON(MOSFET)total[t_3-t_4]} + P_{SWOFF(diode)}|_{[t_3-t_4]} = F_{sw} V_{out} \left( \frac{1}{2} I_0 t_b' \right) + F_{sw} V_{out} \left( \frac{1}{3} I_{RM} t_b - \frac{1}{3} I_{RM} t_b \right) + F_{sw} V_{out} Q_b \text{ Equation 9}$$

Losses independent of the diode / Losses due to the diode

By adding Equation 8 and Equation 9 and by taking into account only the power losses due to the diode, we obtain:

$$P_{SWON(MOSFET+diode)_{duetodiode}} = F_{sw} V_{out} \left( \frac{I_0 I_{RM}}{\frac{dI_F}{dt}} + Q_{rr} \right) \text{ Equation 10}$$

These equations can be easily used (with parameters indicated in each ST datasheet) by considering the switching losses induced by the diode turn-off during MOSFET turn-on (for example to compare different products). To calculate the turn-off power losses in the diode, Equation 5 of paragraph 2.1.1 can be used.

Based on Equation 10, we can conclude that for two diodes with identical  $Q_{rr}$ , the lower the  $I_{RM}$  of the diode is, the lower its switching power losses will be.

Unlike the above calculations, in the next section the calculations are done with real waveforms, without approximations, to get more accurate results:

- The non-linearity of  $dI/dt$  and  $dV/dt$  is taken into account
- $t_b \neq t_b$

### 2.2.2 Turn-off power losses generated by the diode: calculation from real waveforms

The following waveforms have been observed across a diode and the associated MOSFET in a basic switching cell circuit. During the voltage measurement, the probe can introduce some parasitic inductance. The sum of all this inductance is called  $L_p$ .

In real waveforms, the effects of parasitic inductance  $L_p$  can be observed in the graph with a voltage fall corresponding to  $L_p dI_Q/dt$  (in Figure 12: "Real current and voltage waveforms of a switching cell during MOSFET turn-on and diode turn-off phases").

Figure 12: Real current and voltage waveforms of a switching cell during MOSFET turn-on and diode turn-off phases

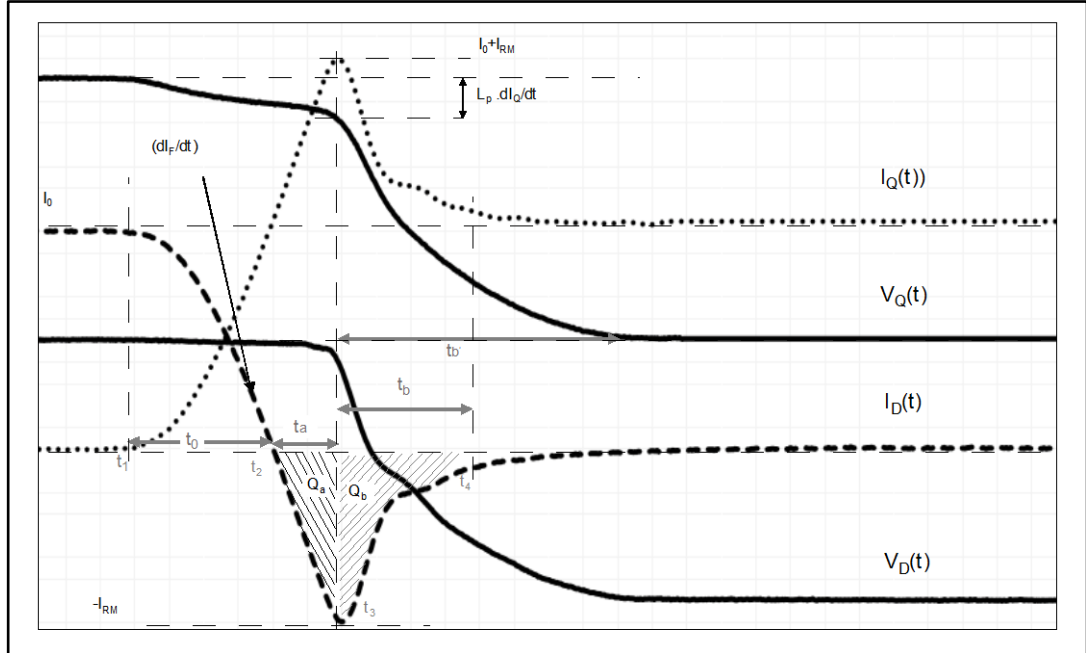

As previously mentioned, any approximation is done on  $dV/dt$ ,  $dI/dt$  and  $t_b$  and  $t_b'$  in the following equations. Moreover, we assume that the  $dV/dt$  is independent of the switching behavior of the diode.

From real waveforms in [Figure 12: "Real current and voltage waveforms of a switching cell during MOSFET turn-on and diode turn-off phases"](#) and without taking into account the parasitic inductance contribution, we can calculate that:

- MOSFET turn-on power losses between  $t_1$  and  $t_3$  are (with  $P_{SWOFF(diode)}[t_1-t_3] = 0$ ):

$$P_{SWON(MOSFET)}[t_1-t_3] = F_{sw} V_{out} \int_{t_1}^{t_2} I_Q(t) \cdot dt + F_{sw} V_{out} \int_{t_2}^{t_3} I_Q(t) \cdot dt$$

with

$$I_0 = I_Q + I_D$$

$$P_{SWON(MOSFET)}[t_1-t_3] = F_{sw} V_{out} \left[ \int_{t_1}^{t_2} I_Q(t) \cdot dt + \int_{t_2}^{t_3} I_0 \cdot dt - \int_{t_2}^{t_3} I_D(t) \cdot dt \right]$$

$$P_{SWON(MOSFET)}[t_1-t_3] = F_{sw} V_{out} \left( \int_{t_1}^{t_2} I_Q(t) \cdot dt \right) + F_{sw} V_{out} I_0 t_a + F_{sw} V_{out} Q_a \quad \text{Equation 11}$$

Losses independent of the diode / Losses due to the diode

MOSFET turn-on power losses and diode turn-off power losses between  $t_3$  and  $t_4$  are:

$$P_{SWON(MOSFET)}[t_3-t_4] + P_{SWOFF(DIODE)}[t_3-t_4] = F_{sw} \int_{t_3}^{t_4} I_Q(t) V_{DS}(t) dt + F_{sw} \int_{t_3}^{t_4} I_D(t) V_D(t) dt$$

with  $I_0 = I_Q + I_D$  and  $V_{out} = V_{DS} - V_D$ , the above equation becomes:

$$P_{SWON(MOSFET)}[t_3-t_4] + P_{SWOFF(DIODE)}[t_3-t_4] = F_{sw} \int_{t_3}^{t_4} (I_0 - I_D(t)) V_{DS}(t) dt + F_{sw} \int_{t_3}^{t_4} I_D(t) (V_{DS}(t) - V_{out}) dt$$

$$= F_{sw} \int_{t_3}^{t_4} I_0 V_{DS}(t) dt - F_{sw} V_{out} \int_{t_3}^{t_4} I_D(t) dt$$

$$P_{SWON(MOSFET)}[t_3-t_4] + P_{SWOFF(DIODE)}[t_3-t_4] = F_{sw} I_0 \int_{t_3}^{t_4} V_{DS}(t) dt + F_{sw} V_{out} Q_b \quad \text{Equation 12}$$

Losses independent of the diode / Losses due to the diode

The power losses in the diode, and the MOSFET generated by the diode, can be deduced from equation (11) and (12):

$$P_{SW(MOSFET+diode)}[duetodiode] = F_{sw} V_{out} (I_0 t_a + Q_{rr}) \quad \text{Equation 13}$$

Equation (13) is close to equation (10) with the advantage that the non-linearity of the  $dI/dt$  is taken into account. However,  $t_a$  is not specified in the datasheet, and should be measured in the application. One of the interesting aspects of this formula (where MOSFET switching-on power losses and diode switching-off power losses are added) is that the calculation does not involve the  $dV/dt$ .



### 2.2.3 Calculation based on energy measurements

In this section, energy measurements are used to evaluate the power losses in a switching cell during the main switch turn-on. In the first step, an example of energy measurements from the scope at the switch turn-on phase is represented. Measurements are done by considering an ST ultrafast diode (STTH15AC06) and a MOSFET in a switching cell in hard switching conditions (as in [Figure 10: "Freewheeling diode in a basic switching cell"](#)). In the second step, the power losses generated by the ultrafast diode during the MOSFET turn-on phase is deduced by replacing the silicon diode with a SiC Schottky diode that exhibits negligible turn-off power losses. Finally, this result is compared to calculate power losses by using [Equation 10](#).

- The first step consists of measuring the voltage and the current flowing through the MOSFET during its turn-on phase to estimate the total energy in the MOSFET due to the diode turn-off.

Figure 14: MOSFET turn-on total energy measurement with an ultrafast diode

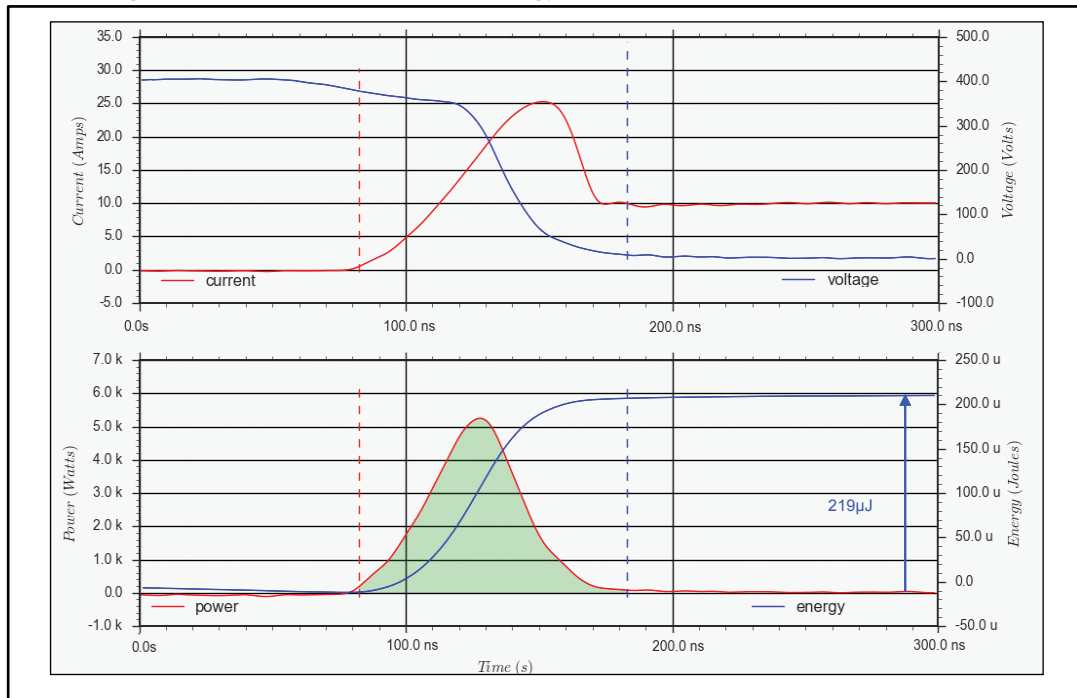

Depending on the current probe used, a time interval may be observed between the current and the voltage curves. It is important to measure this time interval and offset it in order to obtain the current and the voltage in phase. Otherwise the energy measured would be not accurate enough. In most oscilloscopes, the time delay correction function is called "deskew". This time can be easily measured on a resistive circuit by comparing start time between the voltage and the current curves. In our measurement example, a correction of 12 ns has been applied on the current probe to accommodate the current and the voltage waveforms.

- In the second step, the ultrafast diode is replaced with a silicon carbide Schottky diode (SiC diode), with no reverse recovery charges, in order to measure the switching energy exclusively generated by the MOSFET (corresponding to area 5 of [Figure 13: "Ideal current and voltage waveforms of a switching cell during MOSFET turn-on phase and diode turn-off phase"](#))



Figure 15: MOSFET turn-on energy measurement with SiC diode

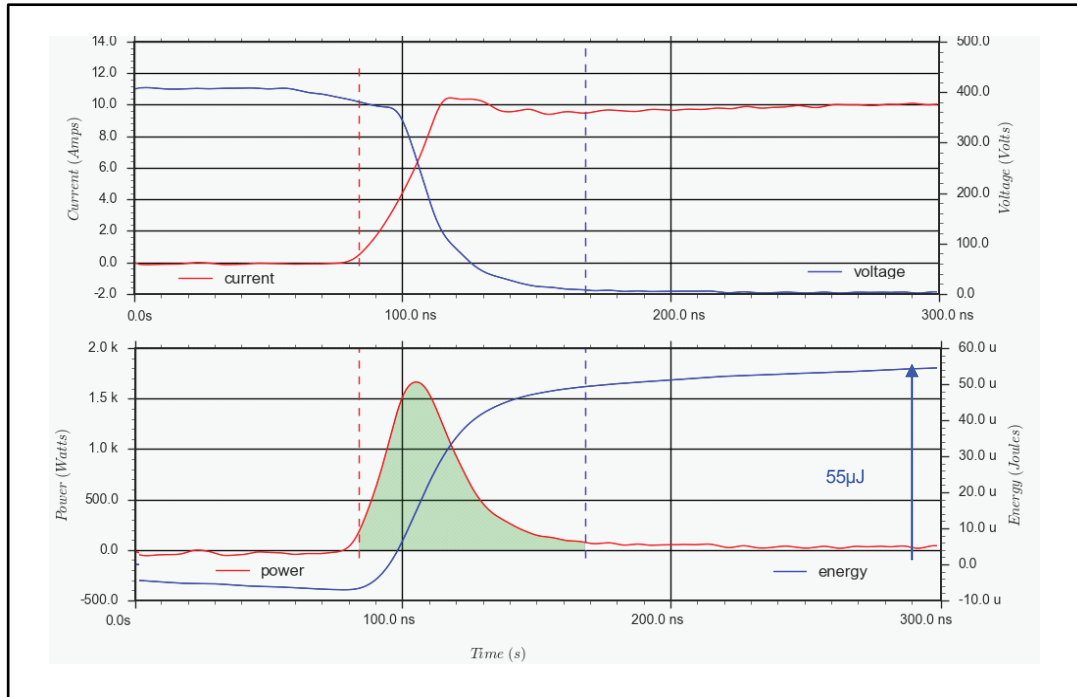

By subtracting the energy measured in [Figure 15: "MOSFET turn-on energy measurement with SiC diode"](#) from the energy measured in [Figure 14: "MOSFET turn-on total energy measurement with an ultrafast diode"](#), we get the energy exclusively dependent of the switching parameters of the ultrafast diode at the MOSFET turn-on:

$$E_{on\_MOSFET(duetodiode)} = E_{on\_MOSFET\_total(withultrafastdiode)} - E_{on\_MOSFET\_total(withSiCdiode)} = 219\mu J - 55\mu J = 164\mu J$$

To get the total energy in the switching cell due to the diode turn-off, we need to include the diode turn-off energy measurement. The [Figure 16: "Ultrafast diode turn-off energy measurement"](#) shows that this energy is equal to 163 μJ.

Figure 16: Ultrafast diode turn-off energy measurement

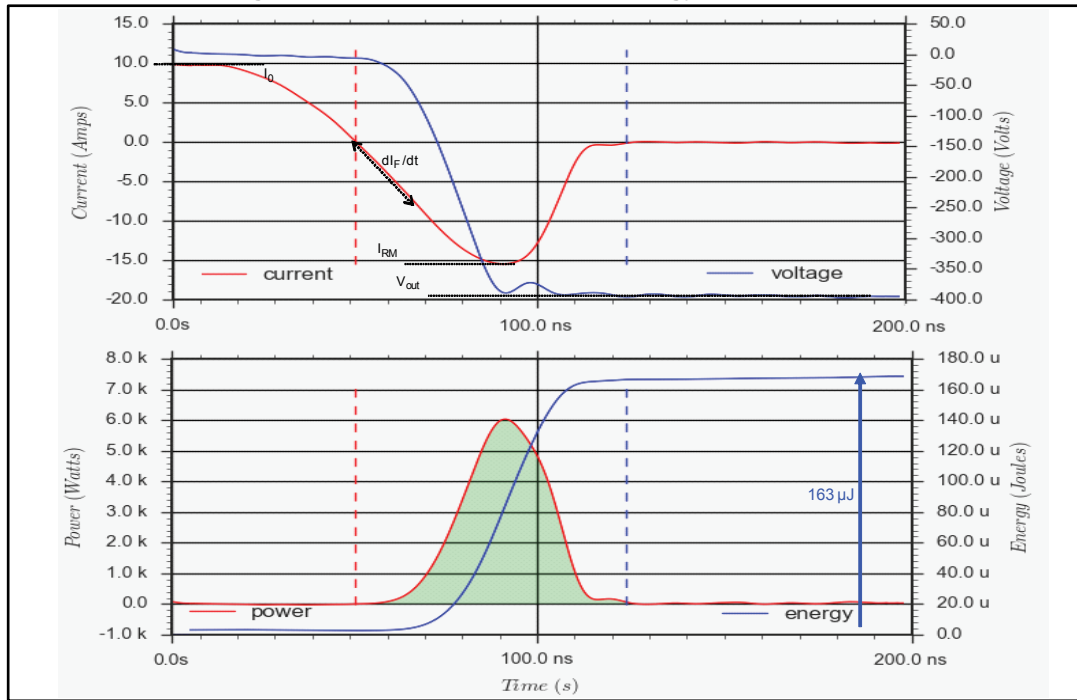

$$E_{SW(MOSFET+diode)_{duetothediode}} = E_{onMOSFET(duetodiode)} + E_{offdiode} = 164\mu J + 163\mu J = 327\mu J$$

Finally, this energy is compared to the result from the [Equation 10](#) by using only the switching parameters of the diode measured in [Figure 16: "Ultrafast diode turn-off energy measurement"](#):

Table 1: Result

Q <sub>rr</sub>	I <sub>RM</sub>	dI <sub>F</sub> /dt	I <sub>o</sub>	V <sub>out</sub>
582 nC	15.5 A	455 A/μs	9.6 A	400 V

$$E_{SW(IGBT+diode)_{duetodiode}} = V_{out} \left( \frac{I_o I_{RM}}{\frac{dI_F}{dt}} + Q_{rr} \right) = 363\mu J$$

For instance, in a 30 kHz frequency application, the power losses difference between the theoretical calculation and the measurements is around 1 W (~10%).

Even if the power losses due to the diode calculated using [Equation 10](#) are a bit more pessimistic than the energy measurement method result, the difference is very small. This means that the calculation with [Equation 10](#) can be used to quickly compare, with good degree of confidence, ultrafast diodes with different switch-off behaviors.

### 3 Conclusion

The turn-off power losses combined with the conduction power losses (in application note [www.st.com/an604](http://www.st.com/an604)) are the main power losses that should be taken into consideration when using ultrafast diodes.

Throughout this application note, different equations for power losses calculation, through different electronic power circuit configurations, are given. They enable designers to easily estimate power losses with relatively good accuracy. Knowing those power losses, designers can select a suitable diode for a given application and estimate the diode junction temperature.

However, as previously mentioned, the energy measurements method remains the best way to accurately evaluate power losses.

### 4 Revision history

Table 2: Document revision history

Date	Revision	Changes
03-Oct-2017	1	First release.

**IMPORTANT NOTICE – PLEASE READ CAREFULLY**

STMicroelectronics NV and its subsidiaries ("ST") reserve the right to make changes, corrections, enhancements, modifications, and improvements to ST products and/or to this document at any time without notice. Purchasers should obtain the latest relevant information on ST products before placing orders. ST products are sold pursuant to ST's terms and conditions of sale in place at the time of order acknowledgement.

Purchasers are solely responsible for the choice, selection, and use of ST products and ST assumes no liability for application assistance or the design of Purchasers' products.

No license, express or implied, to any intellectual property right is granted by ST herein.

Resale of ST products with provisions different from the information set forth herein shall void any warranty granted by ST for such product.

ST and the ST logo are trademarks of ST. All other product or service names are the property of their respective owners.

Information in this document supersedes and replaces information previously supplied in any prior versions of this document.

© 2017 STMicroelectronics – All rights reserved