



# Automotive Standard Analog Robustness and performance



# Contents

- 4 Introduction
- 6 Automotive grade qualification process
- 8 DFN/QFN Wettable flanks  
automotive grade packages
- 9 Power management & system basis ICs
- 9 Power management integrated circuits (PMICs)
- 12 System basis chips (SBCs)
- 15 DC-DC switching regulators
- 15 DC-DC switching regulators from vehicle battery
- 18 DC-DC switching regulators for post-regulation
- 19 Linear voltage regulators (LDOs)
- 19 Linear voltage regulators from vehicle battery
- 22 Linear voltage regulators for post-regulation
- 25 LED/OLED Drivers
- 25 Switching LED drivers
- 27 Linear LED drivers
- 32 Linear OLED drivers

<b>34</b>	<b>Operational amplifiers &amp; Comparators</b>
34	Low-power operational amplifiers
36	Precision operational amplifiers
39	High output current operational amplifiers
41	High bandwidth operational amplifiers
43	High temperature operational amplifiers
45	High speed comparators
46	Low power and high temperature comparators
<b>48</b>	<b>Current sense amplifiers</b>
48	High-side and high temperature current sense amplifiers
50	Low-side current sense amplifiers
<b>51</b>	<b>Voltage references</b>
<b>52</b>	<b>Watchdog, reset and supervisor ICs</b>
<b>53</b>	<b>Logic ICs</b>
<b>54</b>	<b>eDesignSuite</b>

# Introduction



ST provides a wide range of analog products dedicated to the challenging and demanding automotive market.

This brochure presents a comprehensive portfolio of ST products and solutions dedicated to power management, signal conditioning, and many other small analog ICs needed for today's ever-growing automotive industry.

Thanks to innovative design techniques and a continuous focus on improving quality, ST offers high-performance devices that meet the specific requirements of the automotive market segment.

With a continuously expanding portfolio offering the latest solutions across a wide range of packages, from powertrain, safety, and car-body systems to infotainment, this brochure showcases the best products with development tools to help designers quickly start their designs and support their day-to-day activities.

## A LARGE PORTFOLIO OF PRODUCTS

**Power management and system basis ICs**



**DC-DC switching regulators**



**Linear voltage regulators (LDOs)**



**LED/OLED drivers**



**Amplifiers and comparators**



**Current sense amplifiers**



**Voltage references**



**Watchdog, reset, and supervisor ICs**



**Logic ICs**



# Automotive grade qualification process

80%

of all innovations in the automotive industry today are enabled by electronics

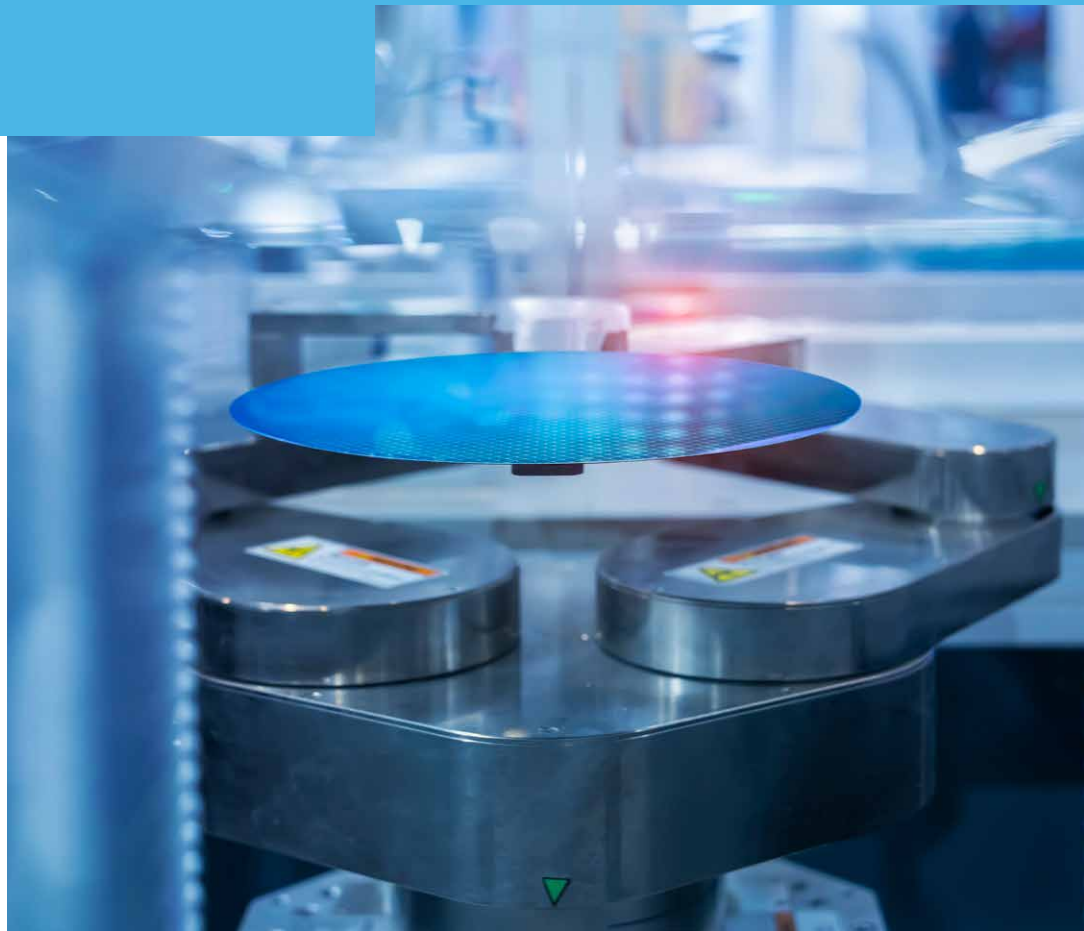

Our automotive products meet the specific and rigorous requirements of the automotive market. This is the result of continuous quality and reliability improvements gained through our close collaboration with leading automotive suppliers and car makers. From product conception to delivery and beyond, our constant focus on learning and upgrading our quality processes, ensure we reach the highest level of excellence in the semiconductor industry.



Very high level of in-house parametric testing equipment



100% electrical testing with very extensive coverage coupled with automatic visual inspection



Part average testing (PAT) to detect and remove parts tested "pass" but potentially weak in reliability



Hot test & junction verification test (JVT) at final test for SOT23, Mini-SO, SO, TSSOP, QFN/DFN



A specific commercial product number

### COMPLIANCE WITH

- IATF16949
- AEC-Q100
- ISO 262262



#### CUSTOMER QUALITY

- Customer requirements
- Complaint management
- Product return process



#### CHANGE MANAGEMENT

- Product/process change notifications
- Product termination notifications



#### MANUFACTURING & SUPPLY CHAIN QUALITY

- Non-conformity management
- Supplier quality management
- Traceability



#### QUALITY IN PRODUCT & TECHNOLOGY DEVELOPMENT

- Test flow
- Technology development
- Product monitoring



# DFN/QFN wettable flanks

## Automotive grade packages

### MAIN FEATURES AND BENEFITS

Packages with wettable flanks (WF) are a new type of plastic packages for ICs, where a modification of the mounting edge design includes a fillet as termination that allows you to see and test whether a proper connection has been made on a pad that is mostly not visible once soldered on a board.

Using a QFN/DFN package with wettable flanks enables automated optical inspection (AOI) of the soldering, which can increase reliability while reducing cost at the same time.

STMicroelectronics is adopting this innovative solution to comply with the stringent requirements of the automotive industry.

Packages with wettable flanks (WF) are immune to soldering cracking for more than 3,000 thermal cycles at -40 to 125°C, 1 cycle per hour, on a 1.0 mm high TG FR-4 PCB (printed circuit board).

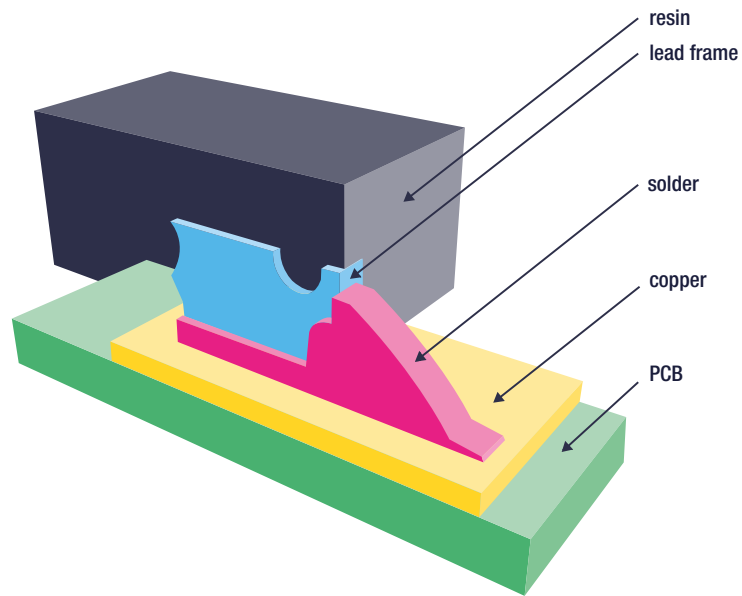

Wettable flanks package structure – internal layers

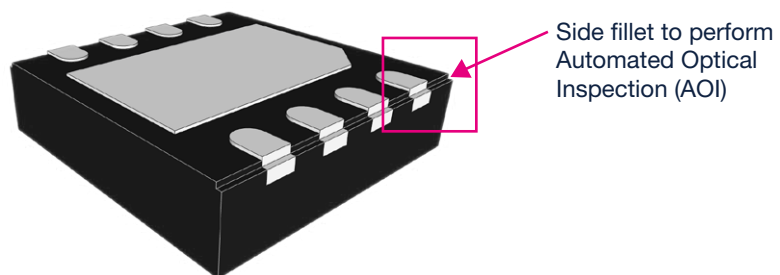

DFN8  
(3x3 WF)

(thickness 0.75mm)

Wettable flanks package example - external view

# Power management and system basis ICs

## POWER MANAGEMENT INTEGRATED CIRCUITS (PMICs)

### SPSA068: PMIC to supply single rail MCU

The **SPSA068** is a buck voltage regulator designed with an accurate voltage reference tailored for microcontroller (MCU) applications. The regulator integrates internal power switches for efficient operation. Its low power mode (LPM) enables functionality during light-load conditions, significantly lowering the quiescent current to a typical value of  $50 \mu\text{A}$ . The device includes an internal non-volatile memory (NVM) that allows configuration of key parameters such as output voltage levels and switching frequencies. Communication and control are facilitated via an SPI interface, which supports diagnostics, programming, monitoring, and an external window watchdog function. Additionally, the SPSA068 incorporates a comprehensive set of features to meet functional safety standards in compliance with automotive safety integrity levels (ASIL), making it suitable for safety-critical automotive applications.

### SPSA068 block diagram

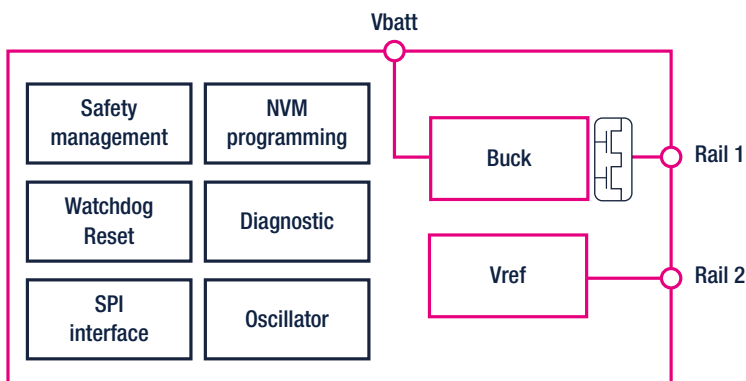

### MAIN FEATURES

- AEC-Q100 qualified
- ASIL-B compliant
- 4.2 to 19 V input voltage (42 V AMR)
- 1x buck regulator (pre-reg) @  $1.6 \text{ A}_{\text{PEAK\_SW}}$  programmable  $V_{\text{out}}$  via NVM
- 1x precise voltage reference (1%), programmable  $V_{\text{out}}$  via NVM @  $20 \text{ mA}$
- Tracking of  $V_{\text{BUCK}}$  in power-up phase
- Standby mode  $I_{\text{q}} < 5 \mu\text{A}$
- Low quiescent current,  $50 \mu\text{A}$
- SPI interface with CRC
- Programmable soft-start
- Voltage supervisors
- Spread frequency spectrum
- Reset output
- Adjustable window watchdog supervisors
- Short-circuit protected outputs and fault detection
- Low external component number
- Thermal warning and thermal shutdown
- Package: QFN32L (5x5)

## STPM066S: PMIC for ADAS applications

The **STPM066S** is a multi-output voltage regulator designed to optimize quiescent current and minimize BOM cost. It features a battery compatible buck pre-regulator, a boost converter (which can be used, for example, to power a CAN bus), one LDO, and a precise voltage reference regulator.

The STPM066S simplifies system design thanks to its one-time programmable (OTP) memory, which allows output parameters to be defined and proper power-on sequencing to be implemented. It also integrates watchdog supervisors, diagnostic indicators, MCU reset control, and a serial peripheral interface (SPI) for MCU configuration and status monitoring. Furthermore, the device supports functional safety in compliance with the automotive safety integrity level (ASIL) standard.



### STPM066S block diagram

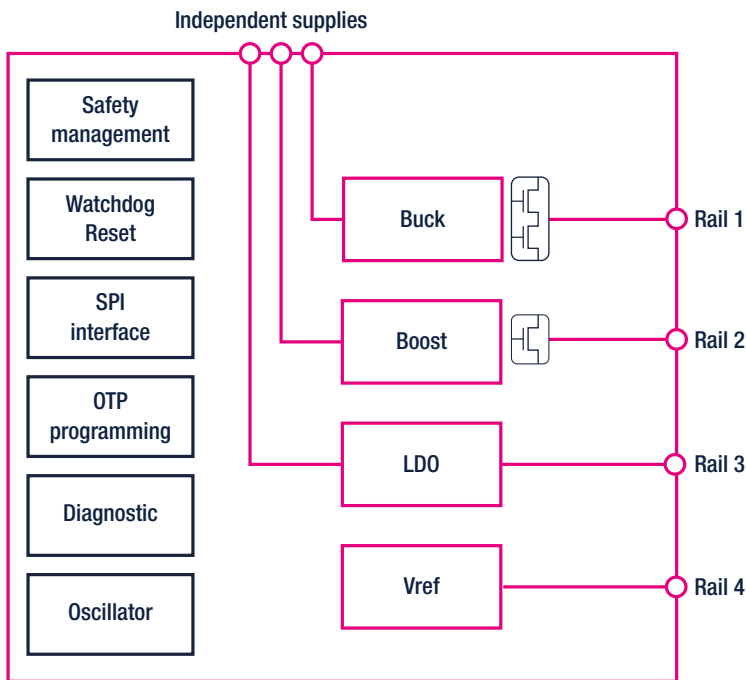

### MAIN FEATURES

- AEC-Q100 qualified
- ASIL-B compliant
- 4 to 32 V input voltage (42 V AMR)
- 1x buck regulator (pre-reg), programmable  $V_{out}$  via OTP @  $2.5 A_{PEAK\_SW}$
- 1x boost regulator, programmable  $V_{out}$  via OTP @  $0.5 A_{PEAK\_SW}$
- 1x linear regulator LDO, programmable  $V_{out}$  via OTP @  $0.6 A_{LJM}$
- 1x precise voltage reference (1%), programmable  $V_{out}$  via OTP @ 20 mA
- SPI interface with CRC
- Programmable slew rate/soft-start
- Voltage supervisors
- Spread frequency spectrum
- Reset and reset sensitivity list
- Adjustable window watchdog supervisors
- Programmed power-up phase via OTP
- Short-circuit protected outputs and fault detection
- Low external components number
- Thermal warning and thermal shutdown
- Package: VQFN48 (7x7)



## Power management integrated circuits (PMICs)

Part number	Operating $V_{IN}$ (V)	AMR $V_{IN}$ (V)	Rails					ASIL	Other features	Package
			Type	$V_{BATT}$ compatible	$V_{OUT}$ (V)	$I_{PK\_SW}$ , $I_{LIM}$ (A)	$f_{SW}$ (MHz)			
STPM066S	4 to 32	42	Buck	Yes	Adjustable via OTP	2.5	0.4 / 2.4	ASIL-B	<ul style="list-style-type: none"> <li>• OTP programming</li> <li>• SPI interface</li> <li>• WD &amp; reset</li> <li>• Spread spectrum</li> <li>• Voltage supervisors</li> </ul>	VQFPN48 (7x7)
			Boost	-		0.5	2.4			
			LDO	-		0.6	-			
			Vref	Yes		0.02	-			
L5965	4 to 32	42	Buck 1	Yes	Adjustable via OTP	Controller	0.4	ASIL-B	<ul style="list-style-type: none"> <li>• OTP programming</li> <li>• SPI interface</li> <li>• WD &amp; reset</li> <li>• Spread spectrum</li> <li>• Voltage supervisors</li> </ul>	VQFPN48 (7x7)
			Buck 2	Yes		2.6	0.4 / 2.4			
			Buck 3	-		1.4	2.4			
			Buck 4	-		1	2.4			
			Boost	-		0.5	2.4			
			LDO	-		0.6	-			
			Vref	Yes		0.02	-			
L5963	3.5 to 26	40	Buck 1	Yes	1 to $V_{in}$	3	2	-	<ul style="list-style-type: none"> <li>• 1x HS driver</li> <li>• Power Good</li> </ul>	PowerSS036 (10x10) VQFPN48 (7x7)
			Buck 2	Yes	1 to $V_{in}$	2.5	2			
			LDO/ST-BY1	Yes	1 to $V_{in}$	0.25	-			
L5964	3.3 to 26	40	Buck 1	Yes	1 to $V_{in}$	3.7	2.2	-	<ul style="list-style-type: none"> <li>• 1x HS driver</li> <li>• Power Good</li> <li>• WD &amp; reset</li> <li>• Voltage supervisors</li> </ul>	LQFP64 (10x10) VQFPN48 (7x7)
			Buck 2	Yes		3.7	2.2			
			LDO/ST-BY1	Yes		0.25	-			
SPSA068	4 to 19	42	Buck	Yes	3.3 / 5	1.6	0.4 / 2.4	ASIL-B	<ul style="list-style-type: none"> <li>• Low power mode</li> <li>• SPI interface</li> <li>• WD &amp; reset</li> <li>• Spread spectrum</li> <li>• Voltage supervisors</li> </ul>	QFN32L (5x5)
			Vref	-	3.3 / 5	0.02	-			
L9001	5.5 to 18	40	Buck 1	Yes	3.3 / 5 / 6	2.2	0.465		<ul style="list-style-type: none"> <li>• WD &amp; reset</li> <li>• Voltage supervisors</li> </ul>	PowerSS024 (10x10)
			Buck 2/LDO1	Yes	5 to 0.8	2.2 / 0.3	0.465			
			LDO2	Yes	3.3 / 5	0.1	-			

## Power management integrated circuits (PMICs) evaluation boards

Part number	Description	Document
STEVAL-SPSA068	Evaluation board based on the SPSA068 automotive PMIC with BUCK and precise voltage reference	Databrief
EVAL-STPM066	Evaluation board based on the STPM066	Databrief
EVAL-L9001	Evaluation board for the L9001 SPS - simple power supply - multiple voltage regulator	Databrief
EVAL-L5965	Evaluation board based on the L5965	Databrief
EVAL-L5963	Evaluation board based on the L5963	Databrief

## Power management integrated circuits (PMICs) application examples

 BMS	 ADAS	 Infotainment	 ECU	 OBC
SPSA068, STPM066S	SPSA068, STPM066S, L5965	SPSA068, STPM066S, L5963, L5964, L5965, L9001	SPSA068, STPM066S, L5965, L9001	SPSA068, STPM066S, L9001

## SYSTEM BASIS CHIPS (SBCs)

### SPSB100G: SBCs for performance class microcontrollers

The **SPSB100G** is fully integrated automotive power management system ICs, especially designed for highly integrated STMicroelectronics microcontrollers (for example, Stellar G and Stellar P families). This device provides both low power mode operation and high current capabilities, delivering enhanced system power supply functionality. The solution combines a 3-switch mode power supply with two integrated linear voltage regulators, offering flexible power management. The device features 2 wake-up inputs and advanced fail-safe mechanisms to enhance reliability. The boost controller is designed primarily to handle transient conditions such as cold cranking pulses, start-stop events, and weak battery scenarios, providing temporary support during these critical periods. Various configurations allow the supply of the system microcontroller, external peripherals, and sensors across multiple adjustable voltage and current levels. Control and diagnostics are facilitated through a standard ST SPI interface, which also supports generic software development. The SPSB100G integrates a CAN-FD transceiver along with additional enhanced features. It includes a comprehensive set of functionalities to support applications requiring compliance with automotive safety integrity levels (ASIL), ensuring adherence to functional safety standards.



### SPSB100G block diagram

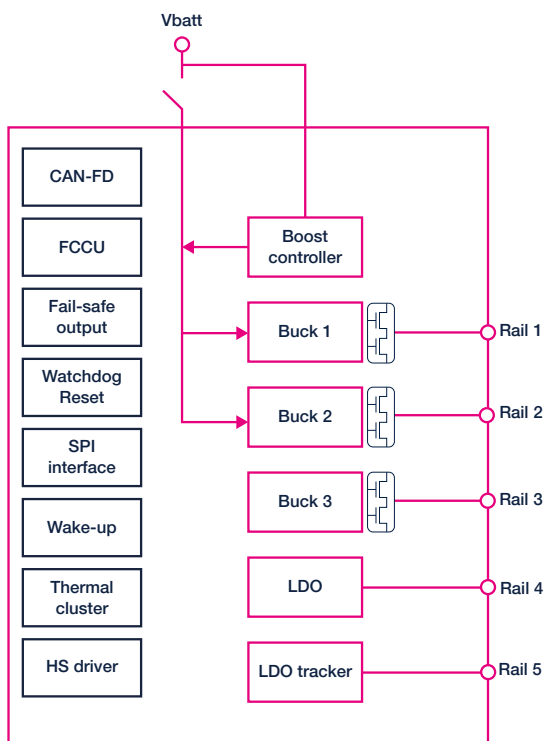

### MAIN FEATURES

- AEC-Q100 qualified
- ASIL-D compliant
- 3 to 29 V input voltage (40 V AMR)
- 2x buck regulators (pre-reg), programmable  $V_{out}$  @3.75 A<sub>PEAK\_SW</sub>
- 1x buck regulator, programmable  $V_{out}$  @6 A<sub>PEAK\_SW</sub>
- 1x boost controller (pre-reg)
- 1x linear regulator LDO, 5 V<sub>out</sub> @120 mA
- 1x linear regulator LDO tracker, 3.3/5 V<sub>out</sub> @10 mA
- One high-side driver for contact monitoring
- Dedicated interrupt pin for failure communication
- Low power mode
- MCU reset generator
- Temperature warning and protection
- Thermal clusters
- A/D conversion of supply voltages and internal temperature sensors
- SPI interface with 4-bit CRC
- Fail-safe output
- Static and dynamic error signal reporting
- Programmable periodic system wake-up feature
- Configurable window watchdog
- Mask function for watchdog
- Very low quiescent current 40  $\mu$ A
- Very long duration timer up to 180 days
- CAN-FD transceiver
- Package: VFQFN56 + 4L (8x8)







## System basis chips (SBCs)

Part number	Operating $V_{IN}$ (V)	AMR $V_{IN}$ (V)	Rails					Transceiver	ASIL	Other features	Package
			Type	$V_{BATT}$ compatible	$V_{OUT}$ (V)	$I_{PK\_SW}$ , $I_{LIM}$ (A)	$f_{SW}$ (MHz)				
SPSB100G	3 to 29	40	Buck 1	Yes	Programmable	3.75	0.4 / 2.4	CAN-FD	ASIL-D	<ul style="list-style-type: none"> <li>Low power mode</li> <li>1x HS driver</li> <li>SPI interface</li> <li>WD &amp; reset</li> <li>Thermal clusters</li> <li>Fail-safe output</li> <li>Mask function for WD</li> <li><math>I_q = 40 \mu A</math></li> <li>180-day long duration timer</li> <li>Available without transceiver (GB version)</li> </ul>	QFN56 +4L (8x8 WF)
			Buck 2	Yes		3.75	0.4 / 2.4				
			Buck 3	-		6	2.4				
			Boost	Yes		Controller	0.4				
			LDO	Yes	5	0.12	-				
			LDO tracker	Yes	Programmable	0.01	-				
SPSB081	5.5 to 28	40	LDO	Yes	Programmable	0.45	-	CAN-FD, LIN	ASIL-D	<ul style="list-style-type: none"> <li>Low power mode</li> <li>4x HS driver</li> <li>SPI interface</li> <li>WD &amp; reset</li> <li>Thermal clusters</li> <li>Fail-safe output</li> <li>Diagnostic</li> <li>Available without LIN transceiver (C version)</li> </ul>	QFN32L (5x5 WF)
			LDO tracker	Yes		0.40	-				
L9396B/L	6 to 19	40	Boost	Yes	9	0.3	2	-	ASIL-D	<ul style="list-style-type: none"> <li>Boost pre-reg for deep cranking</li> <li>2x HS driver</li> <li>SPI interface</li> <li>WD &amp; reset</li> <li>Fail-safe output</li> <li>Spread spectrum</li> <li>4x channels for remote sensor interface</li> </ul>	TQFP64 EP (10x10)
			Buck 1	Yes	6.5 / 7.2	1.8	0.465				
			Buck 2 (B version), LDO 1 (L version)	-	Programmable	1.6 (B version), 0.75 (L version)	0.465 (B version)				
			LDO 2	-	5	0.25	-				
			LDO 3	-	3.3 / 5	0.10	-				
L99PM72GXP L99PM62GXP	4.5 to 28	40	LDO 1	Yes	5	0.25	-	CAN, LIN	-	<ul style="list-style-type: none"> <li>5x HS drivers</li> <li>2x LS relay drivers</li> <li>2x op amps</li> <li>4x PWM generators</li> <li>3x wake-up inputs</li> <li>SPI interface</li> <li>WD &amp; reset</li> <li>Fail-safe output</li> <li>Selective wake-up (L99PM72GXP only)</li> </ul>	PowerSS016 (10x10)
			LDO 2	Yes	5	0.10	-				
L9952GXP	6 to 28	40	LDO 1	Yes	5	0.25	-	LIN	-	<ul style="list-style-type: none"> <li>5x HS drivers</li> <li>2x LS relay drivers</li> <li>2x op amps</li> <li>4x PWM generators</li> <li>4x wake-up inputs</li> <li>SPI interface</li> <li>WD &amp; reset</li> <li>Fail-safe output</li> </ul>	PowerSS016 (10x10)
			LDO 2	Yes	5	0.10	-				
L99PM60J	6 to 28	40	LDO	Yes	5	0.10	-	LIN	-	<ul style="list-style-type: none"> <li>2x HS drivers</li> <li>2x LS relay drivers</li> <li>Wake-up inputs</li> <li>SPI interface</li> <li>WD &amp; reset</li> <li>Fail-safe output</li> </ul>	PowerSS016 (10x10)

## System basis chips (SBCs) evaluation boards

Part number	Description	Document
AEK-POW-SPSB081	Automotive power management IC evaluation board with LIN and CAN-FD based on SPSB081	Databrief
EVAL-L99PM62-72	Evaluation board for L99PM62GXP and L99PM72GXP	Databrief

## System basis chips (SBCs) and STMicroelectronics MCUs

Part number	 SR5 family (lines)	 SR6 family (lines)	 SP56 family (lines)	 SPC58 family (lines)
SPSB100G	-	G7, P6, P7	-	-
SPSB081	-	-	ALL	2B, 4B, C
L9396B/L	E1	-	ALL	2B, 4B, C

## System basis chips (SBCs) application examples

 EPS, ABS	 OBC	 ECU	 Infotainment	 BMS	 HVAC	 Seat control
L9396B/L	L9396B/L	L9396B/L, SPSB100G	SPSB100G		SPSB081, L99PM72GXP, L99PM62GXP	SPSB081, L99PM60J, L9952GXP

# DC-DC switching regulators

## DC-DC SWITCHING REGULATORS FROM VEHICLE BATTERY

### A6983I: 38 V, 3 A isolated synchronous buck converter for isolated applications

The **A6983I** is a device specifically designed for isolated buck topology. The primary output voltage can be accurately adjusted, regulated, while the isolated secondary output is generated based on a fixed transformer turns ratio, eliminating the need for an optocoupler.

With an output current capability of up to 3 A on the primary side, the A6983I ensures efficient energy transfer to the secondary side and supports a controlled soft-start sequence for the secondary output. The device incorporates a spread spectrum feature to improve electromagnetic compatibility (EMC). Its control loop employs a peak current mode architecture and operates in forced PWM mode. A 390 ns blanking time effectively filters oscillations caused by transformer leakage inductance, enhancing overall system robustness. The A6983I is well-suited for a variety of applications in electric and hybrid vehicles, including power supplies for gate drivers of both IGBT- and SiC MOSFET-based electric traction systems, on-board chargers (OBC), battery management systems, and any application requiring isolated single or dual output supplies.

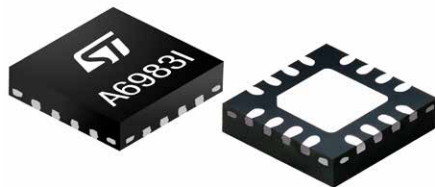

### MAIN FEATURES

- AEC-Q100 qualified
- Designed for isolated buck topology
- Primary output voltage regulation/ no optocoupler
- 3.5 to 38 V operating input voltage
- 3 A output current capability at primary side
- 200 kHz to 1 MHz programmable switching frequency
- 25  $\mu$ A operating quiescent current
- 2  $\mu$ A shutdown current
- Spread spectrum for improved EMC
- Synchronization to external clock
- Internal soft-start and compensation network
- Power Good, and enable pin
- Package: QFN16 (3x3 WF)

## A6983I typical application schematic

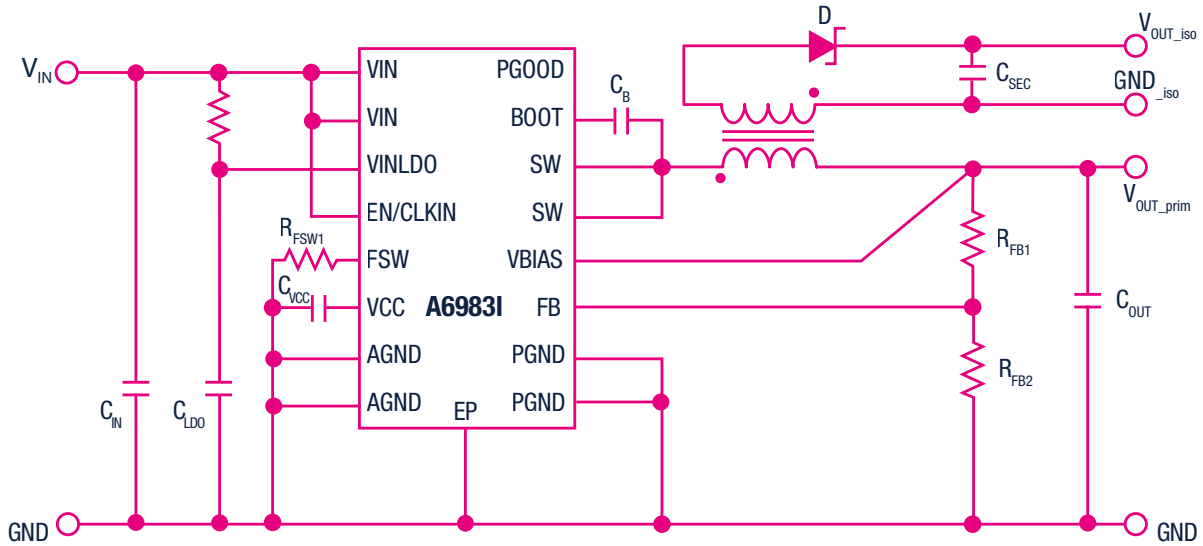

## DC-DC switching regulators from vehicle battery - synchronous converter ICs

Part number	Operating $V_{IN}$ (V)	AMR $V_{IN}$ (V)	$I_{OUT}$ (A)	$V_{OUT}$ (V)	Frequency (MHz)	$I_q$ ( $\mu A$ )	Other features	Package	Vehicle battery type compatibility (V)
A6983	3.5 to 38	42	3	Adj.(0.85- $V_{IN}$ )	0.2 to 2.3	17	Buck, $T_{ONmin} = 75$ ns, adj. $f_{SW}$ , Spread Spectrum, synchronization, internal compensation, PGGOOD, low noise or low consumption mode	QFN16 (3x3 WF)	12
A6983I	3.5 to 38	42	3*	Adj.(0.85- $V_{IN}$ )*	0.2 to 1	17	Isolated Buck, $T_{ONmin} = 75$ ns, adj. $f_{SW}$ , Spread Spectrum, synchronization, internal compensation, PGGOOD, low noise or low consumption mode	QFN16 (3x3 WF)	12
A6986	4 to 38	40	2	Adj. (0.85 - $V_{IN}$ ) Fixed (5, 3.3)	0.25 to 1	30	Buck, $T_{ONmin} = 80$ ns, synchronization, adj. $f_{SW}$ selectable SKIP/PWM Thsr., adj. soft-start and PGGOOD, adj. reset, low noise or low consumption mode, OV and OC protection	HTSSOP16 (5x6.5)	12
A6986I	4 to 38	40	2*	Adj.(0.85- $V_{IN}$ )*	0.25 to 1	30	Isolated buck, $T_{ONmin} = 300$ ns, synchronization, adj. $f_{SW}$ , adj. soft-start and PGGOOD, adj. reset, OV and OC protection	HTSSOP16 (5x6.5)	12
A6986F	4 to 38	40	1.5	Adj. (0.85 - $V_{IN}$ ) Fixed (5, 3.3)	0.25 to 2	30	Buck, $T_{ONmin} = 100$ ns, synchronization, adj. $f_{SW}$ , adj. soft-start and PGGOOD, adj. reset, low noise or low consumption mode, OV and OC protection	HTSSOP16 (5x6.5)	12
A6985F	4 to 38	40	0.5	Adj. (0.85 - $V_{IN}$ ) Fixed (5, 3.3)	0.25 to 2	30	Buck, $T_{ONmin} = 100$ ns, synchronization, adj. $f_{SW}$ , adj. soft-start and PGGOOD, adj. reset, low noise or low consumption mode, OV and OC protection	HTSSOP16 (5x6.5)	12

Note \* Value at primary side

## DC-DC switching regulators from vehicle battery - controller and asynchronous converter ICs

Part number	Operating $V_{IN}$ (V)	AMR $V_{IN}$ (V)	$I_{OUT}$ (A)	$V_{OUT}$ (V)	Frequency (MHz)	Other features	Package	Vehicle battery type compatibility (V)
<b>Controller ICs</b>								
STPM802A	6 to 36	60	$I_{ext-mosfet}$	Adj. (3.3 to 14)	0.177 to 0.5	Buck-boost controller single phase with 4-switches, adj. $f_{SW}$ , spread spectrum, stand-by, integrated bootstrap diode	VQFN32+4L (5x5)	24
<b>Asynchronous converter ICs</b>								
A7987	4.5 to 61	61	3	Adj. (0.8 to $V_{IN}$ )	0.25 to 1.5	Buck, synchronization, adj. $f_{SW}$ , Power Good, adj. soft-start, adj. current limit	HTSSOP16 (5x6.5)	24
A7986A	4.5 to 38	45	3	Adj. (0.6 to $V_{IN}$ )	0.25 to 1	Buck, synchronization, adj. $f_{SW}$ , internal soft-start	HS08 (5x6)	12
A7985A	4.5 to 38	45	2	Adj. (0.6 to $V_{IN}$ )	0.25 to 1	Buck, synchronization, adj. $f_{SW}$ , internal soft-start	HS08 (5x6)	12
A5975D	4 to 36	40	3	Adj. (1.235 to 35)	0.25	Buck, synchronization, Vref	HS08 (5x6)	12
A5975AD	4 to 36	40	2.5	Adj. (1.235 to 35)	0.50	Buck, synchronization, Vref	HS08 (5x6)	12
A5973D	4 to 36	40	2	Adj. (1.235 to 35)	0.25	Buck, synchronization, Vref	HS08 (5x6)	12
A5972D	4 to 36	40	1.5	Adj. (1.235 to $V_{IN}$ )	0.25	Buck, synchronization, Vref	S08 (5x6)	12
A5973AD	4 to 36	40	1.5	Adj. (1.235 to $V_{IN}$ )	0.50	Buck, synchronization, Vref	HS08 (5x6)	12
A5970D	4 to 36	40	1	Adj. (1.235 to $V_{IN}$ )	0.25	Buck, synchronization, Vref	S08 (5x6)	12
A5970AD	4 to 36	40	1	Adj. (1.235 to $V_{IN}$ )	0.50	Buck, synchronization, Vref	S08 (5x6)	12

## DC-DC switching regulators from vehicle battery - main evaluation boards

Part number	Description	Documentation
STEVAL-A6983CV1	Evaluation board based on DC-DC converter buck regulator A6983CQTR	DB4805
STEVAL-A6983NV1	Evaluation board based on DC-DC converter buck regulator A6983NQTR	DB4813
STEVAL-A6983IV1	38 V, 10 W isolated buck with 1x configurable (single/dual) isolated output based on A6983I	DB5463
STEVAL-6986YT2DL	5 W dual isolated output, SIP7 compatible, isobuck-boost converter based on A6986I	DB5490
STEVAL-A6986IV3	8 W isobuck-boost converter with four selectable dual voltages based on A6986I	DB5240
STEVAL-A6986IV2	38 V, 5 W isobuck converter evaluation board with single isolated output based on the A6986I	DB4367
STEVAL-A6986IV1	38 V, 5 W isobuck converter evaluation board with dual isolated output based on the A6986I	DB4365
STEVAL-ISA158V1	38 V, 2 A synchronous step-down switching regulator evaluation board based on A6986	DB2477
STEVAL-ISA190V1	38 V, 1.5 A synchronous step-down switching regulator evaluation board based on A6986F	DB2932
STEVAL-ISA189V1	38 V, 1.5 A synchronous step-down switching regulator evaluation board based on A6986F5V	DB2831
STEVAL-ISA188V1	38 V, 1.5 A synchronous step-down switching regulator evaluation board based on A6986F3V3	DB2829
STEVAL-ISA187V1	38 V, 0.5 A synchronous step-down switching regulator evaluation board based on A6985F	DB2823
STEVAL-ISA186V1	38 V, 0.5 A synchronous step-down switching regulator evaluation board based on A6985F5V	DB2820
STEVAL-ISA200V1	High-efficiency synchronous step-down regulator based on A6984	DB3249
STEVAL-ISA207V1	3 A step down DC-DC switching regulator ( $V_{IN} = 4.5$ V to 60 V) based on the A7987	DB3887

### Application example

#### EV traction inverter: isolated gate driver supply based on the STEVAL-A6986IV3

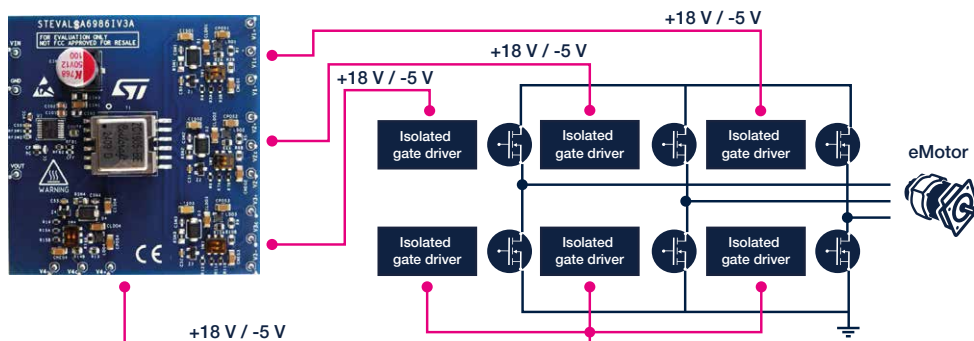

# DC-DC SWITCHING REGULATORS FOR POST-REGULATION

## DCP0606Y: up to 6 V<sub>IN</sub>, 6 A step-down switching regulator

The **DCP0606Y** is a highly efficient monolithic synchronous step-down regulator capable of delivering up to 6 A of continuous current. It operates over an input voltage range from 2.9 V to 6 V. The device incorporates low-resistance integrated N-channel MOSFETs and utilizes a diode emulation mode to maximize efficiency across the entire load spectrum. An internal 0.6 V voltage reference enables output voltage regulation with a precision of ±1.5% across temperature variations. The switching frequency can be externally set between 1.8 MHz and 4 MHz. The soft-start period is configurable via an external capacitor, and the SS/TRK pin can also be employed for output voltage sequencing. Additionally, the RST/PGOOD pin offers real-time status monitoring of the output voltage. The DCP0606Y is housed in a compact 2 x 3 mm QFN package with 11 leads and wettable flanks for enhanced assembly reliability.

### MAIN FEATURES

- AEC-Q100 qualified
- Input voltage: 2.9 to 6 V
- Output voltage: 0.6 V to V<sub>IN</sub>
- Output current: 6 A
- Switching frequency: 1.8 to 4 MHz
- Synchronous rectification
- Integrated 11 mΩ MOSFETs
- Spread spectrum
- Power Good
- External synchronization with program, phase-shift
- Internal soft-start
- Output voltage tracking
- Overcurrent, overvoltage, and current and thermal protections
- Package: QFN11L (2x3 mm)

Efficiency curves V<sub>IN</sub> = 5 V, V<sub>OUT</sub> = 3.3 V, f<sub>sw</sub> = 2.25 MHz

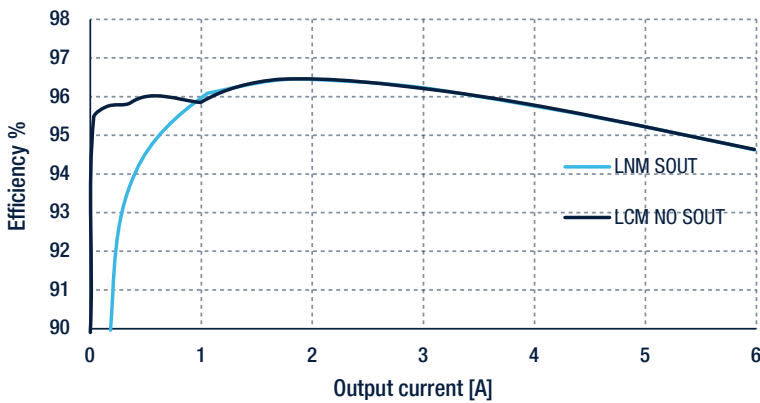

## DC-DC switching regulators for post-regulation

Part number	V <sub>IN</sub> (V)	V <sub>OUT</sub> (V)	I <sub>OUT</sub> (A)	Frequency (MHz)	I <sub>q</sub> (μA)	Type	Other features	Package
DCP0606Y	2.9 to 6	0.6 to V <sub>IN</sub>	6	1.8 to 4	10	Monolithic synchronous converter	Spread spectrum, soft-start, Power Good, output voltage tracking	QFN11(2x3, WF)
AST1S31	2.8 to 4	0.8 to V <sub>IN</sub>	3	1.5	630	Monolithic synchronous converter	Internal compensation, soft-start, Power Good	VFDFPN8 (3x3)
AST1S31HF	2.8 to 4	0.8 to V <sub>IN</sub>	3	2.3	630	Monolithic synchronous converter	Internal compensation, soft-start, Power Good	VFDFPN8 (3x3)
A6727B	1.5 to 12	0.8 to V <sub>IN</sub>	I <sub>EXT-MOS</sub>	0.3	NA	Controller	Soft-start, disable function	S08
STPM098C	4.75 to 5.25	0.5 to 2	I <sub>EXT-MOS</sub>	0.2 to 1.5	NA	Digital controller	8 phases with dual independent voltage loops, PMBus	VFQFN48 (7x7)

## DC-DC switching regulators for post-regulation - main evaluation boards

Part number	Description	Documentation
STEVAL-0606YADJ	3.3 V/6 A automotive step down DC-DC converter (V <sub>IN</sub> up to 6 V) based on the DCP0606Y	DB5512
STEVAL-ISA160V1	3 A / 2.3 MHz step-down synchronous switching regulator based on the AST1S31HF	DB2858
STEVAL-ISA069V1	3 A / 1.5 MHz step-down synchronous switching regulator based on the AST1S31	DB1572

# Linear voltage regulators (LDOs)

## LINEAR VOLTAGE REGULATORS FROM VEHICLE BATTERY

**L99VR02XP: dual automotive linear voltage regulator with configurable output voltage (2x250 mA current capability)**

The **L99VR02XP** is a 28 V/ 2x 250 mA low dropout dual linear regulator with low quiescent current as low as 1  $\mu$ A (per output) when the regulator is disabled. Its input is 40 V tolerant to withstand load dump. Each of the L99VR02XP outputs can be configured, through SELx pins, to generate a fixed output voltage (0.8 V, 1.2 V, 1.5 V, 1.8 V, 2.5 V, 2.8 V, 3.3 V or 5 V). High output voltage accuracy ( $\pm 2\%$ ) is kept over wide temperature range, line and load variation. The L99VR02XP offers a complete set of features (enable, reset, autonomous watchdog, advanced thermal warning, thermal cluster, fast output discharge). Automatic voltage (de)tracking of LDO2 respects the internal LDO1 or of an external voltage regulator and IShort control. The L99VR02XP can operate both in post regulation, attached to a pre-regulated voltage, or directly connected to the battery.



### Output voltage vs. Tj

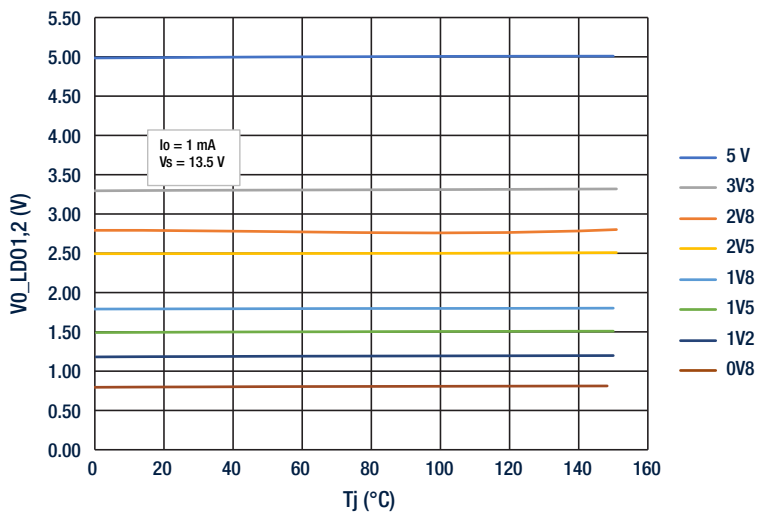

### MAIN FEATURES

- AEC-Q100 qualified
- Input voltage: 2.15 V to 28 V (40 V load dump)
- Dual linear voltage regulators
- Output current: 2x 250 mA
- User-selectable output voltage
- Low quiescent current  $\leq 1 \mu\text{A}$  @LDO disabled
- Output voltage precision  $\pm 2\%$
- Low dropout voltage
- Automatic voltage (de)tracking of LDO2 respect LDO1
- Thermal warning and overvoltage diagnostic
- Enable input
- Output voltage monitoring with reset output
- Thermal shutdown and short-circuit protection, UVLO
- Programmable autonomous watchdog and reset pulse delay
- $T_j = -40^\circ\text{C}$  to  $175^\circ\text{C}$
- Package: PowerSS036



L99VR02XP application schematic - single rail line, dual outputs

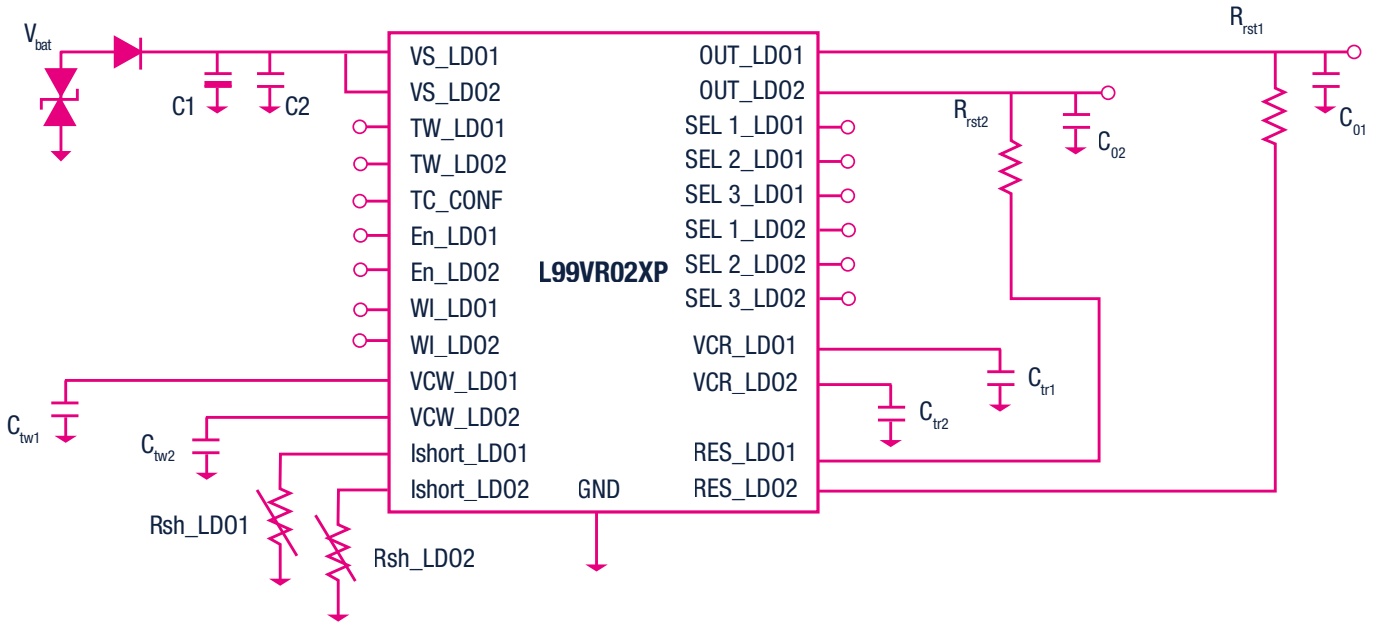

## Linear voltage regulators from vehicle battery

Part number	Operating $V_{IN}$ (V)	AMR $V_{IN}$ (V)	Number of outputs	$V_{OUT}$ (V)	$I_{OUT\_max}$ (mA)	Drop-out voltage (V) @load_max	$I_o$ ( $\mu$ A) @ON mode no load	PSRR @ 1 kHz (dB)	Output noise 10 Hz - 100 kHz ( $\mu$ V)	Other features	Package
<b>LDQ40</b>	3.3 to 40	42	1	Adj (1.2 to 12) Fixed (1.8, 2.5, 3.3, 5)	250	0.5	2	65	50	Enable, soft-start, PGOOD, internal current limit, foldback and thermal protections	DFN6 (2x2 WF) SOT23-5L
<b>LDH40</b>	3.3 to 40	42	1	Adj (1.2 to 22)	200	0.7	2	70	100	Enable, soft-start, PGOOD, internal current limit and thermal protection	DFN6 (2x2 WF) SOT23-5L
<b>LDL40</b>	3.3 to 40	42	1	Adj (1.2 to 12) Fixed (3.3, 5)	200	0.7	2	70	100	Enable, soft-start, PGOOD, internal current limit and thermal protection	DFN6 (2x2 WF)
<b>L99VR01</b>	2.15 to 28	40	1	Fixed - digital selection (0.8, 1.2, 1.5, 1.8, 2.5, 2.8, 3.3, 5)	200	0.5	75	75	65	Enable, reset, UVLO, fast output discharge, short-circuit and thermal protections, programmable ISHORT (L99VR01J), advanced thermal warning and output OVP diagnostic (L99VR01J), $T_j = -40^\circ\text{C}$ to $175^\circ\text{C}$ (L99VR01J)	S08 (6x5) (L99VR01S), PowerSS0-12 (6x5) (L99VR01J)
<b>L99VR02XP</b>	2.15 to 28	40	2	Fixed - digital selection (0.8, 1.2, 1.5, 1.8, 2.5, 2.8, 3.3, 5)	2x250	0.5	115	80	85	Enable, reset, UVLO, programmable watchdog, advanced thermal warning, fast output discharge, short-circuit and thermal protections, thermal clusters, automatic voltage (de) tracking of LDO2 respect LDO1	PowerSS036 (10.3x10.3)
<b>L99VR02J</b>			1		500		105				
<b>L99VR03</b>	4.5 to 28	40	1	Fixed (3.3, 5)	300	0.55	3.5	76	160	Enable, UVLO, short-circuit and thermal protections	PowerSS012 (5x4), VFDFN8L (3x2)
<b>L5050</b>	5.6 to 31	40	1	Fixed (5)	50 or (100 as pulsed current)	0.5	50	60	NA	Enable, short-circuit and thermal protections	S08 (6x5)
<b>L5150GJ, L5150CS, L5150CJ, L5150BN</b>	5.6 to 31	40	1	Fixed (5)	150	0.5	50	48	NA	Enable (L5150GJ), reset (L5150CS/CJ, L5150GJ), early warning (L5150CS/CJ, L5150GJ), short-circuit and thermal protection	PowerSS012 (6x5) (L5150CS/CJ, L5150GJ), S08 (6x5) (L5150CS/CJ), SOT223 (7x6.5) (L5150BN)
<b>L5300AH7</b>	5.6 to 31	40	1	Fixed (5)	300	0.5	55	60	NA	Enable, reset, short-circuit and thermal protection	HPAK (6.5x9.5)
<b>L4995</b>	5.6 to 31	40	1	Fixed (5)	500	0.5	90	75	NA	Enable, reset, watchdog, short-circuit and thermal protection	PowerSS012 (6x5), PowerSS024 (10x10)

# LINEAR VOLTAGE REGULATORS FOR POST-REGULATION

## LD49100: 1 A small package and low quiescent current voltage regulator for all needs

The **LD49100** is a 1 A low-dropout regulator operating from 1.5 V to 5.5 V input, with a typical dropout voltage of 200 mV. It is stable with ceramic capacitors and features low quiescent current and noise, making it ideal for automotive use. The device offers 70 dB power supply rejection at low frequency, an enable-controlled shutdown mode with under 1  $\mu$ A current, and a precise Power Good indicator for monitoring. It includes a 1 ms soft-start to limit inrush current, along with short-circuit current limiting and thermal protection. The LD49100 is AEC-Q100 qualified and comes in a compact 6-pin DFN6 package with wettable flanks.

### Output noise voltage vs. frequency

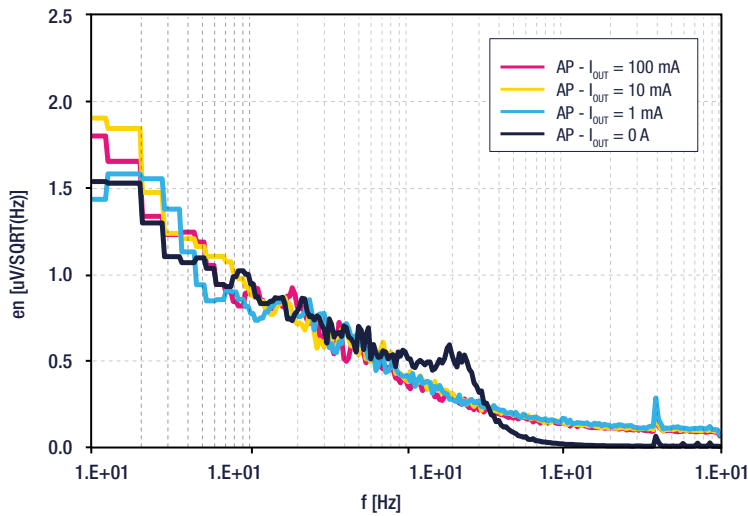

### MAIN FEATURES

- AEC-Q100 qualified
- Input voltage: 1.5 to 5.5 V
- 1 A guaranteed output current
- Ultra-low dropout voltage: 200 mV (typ.) at 1 A load
- Very low quiescent current: 20  $\mu$ A (typ.) at no load
- Enable, Power Good signal
- Soft Start (1 ms)
- Output voltage tolerance:  $\pm 2.0$  % at 25  $^{\circ}$ C
- Package: DFN6 (3x3)

### Supply voltage rejection vs freq. ( $V_{OUT} = 2.5$ V)

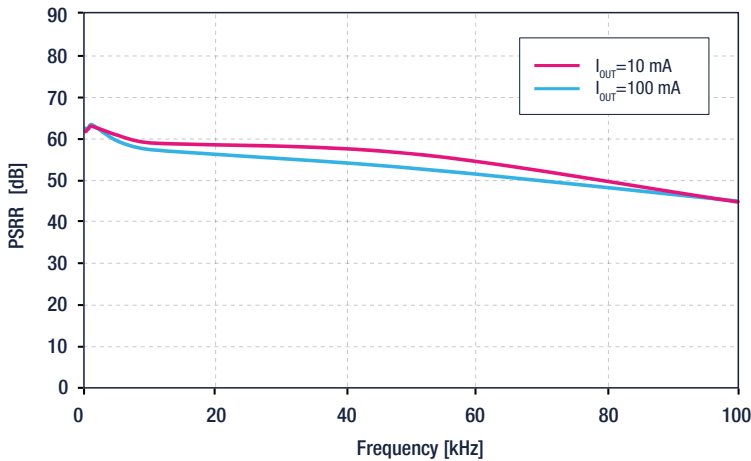

LD49100 application diagram (fixed)

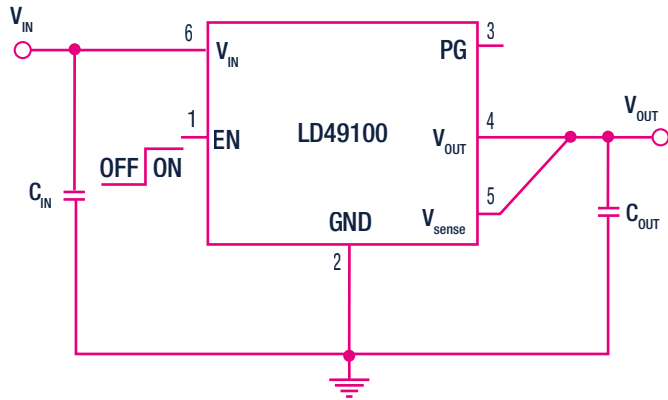

LD49100 application diagram (adjustable)

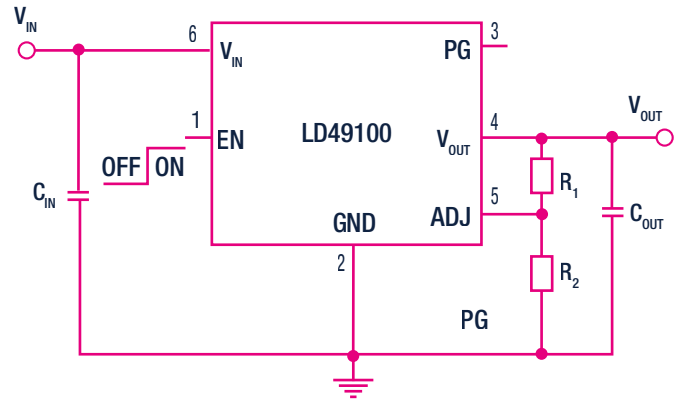

**LDK130: 300 mA SOT-23 cost effective, low noise voltage regulator**

The **LDK130** low-dropout voltage regulator delivers up to 300 mA of current from an input voltage range of 1.9 V to 5.5 V, featuring a typical dropout voltage of 100 mV. It achieves stability when used with a ceramic capacitor on the output. Its ultra-low dropout voltage, low quiescent current, and minimal noise make it ideal for low-power, battery-operated applications. An enable pin allows the device to enter shutdown mode, reducing current consumption to below 1  $\mu$ A.

The LDK130 also incorporates short-circuit constant current limiting and thermal protection for enhanced reliability.

**Dropout voltage vs. temperature**

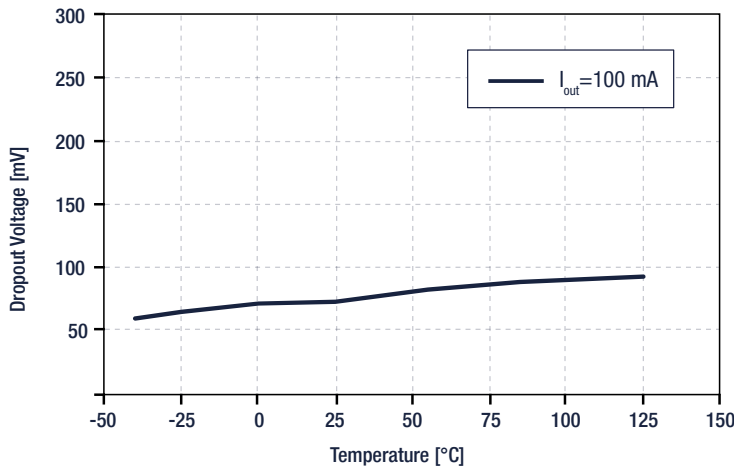

**MAIN FEATURES**

- AEC-Q100 qualified
- Input voltage: 1.9 to 5.5 V
- Very-low dropout voltage: 100 mV (typ.) at 100 mA load
- Low quiescent current: 30  $\mu$ A (typ.) at no load, 1  $\mu$ A (max.) in off mode
- Low-noise
- Output voltage tolerance:  $\pm 2.0$  % at 25 °C
- 300 mA guaranteed output current
- Stable with ceramic capacitors  $C_{OUT} = 1 \mu$ F
- Overcurrent (OC) and thermal protection
- Package: SOT23-5L

**Supply voltage rejection vs freq.  $V_{OUT} = 2.5$  V**

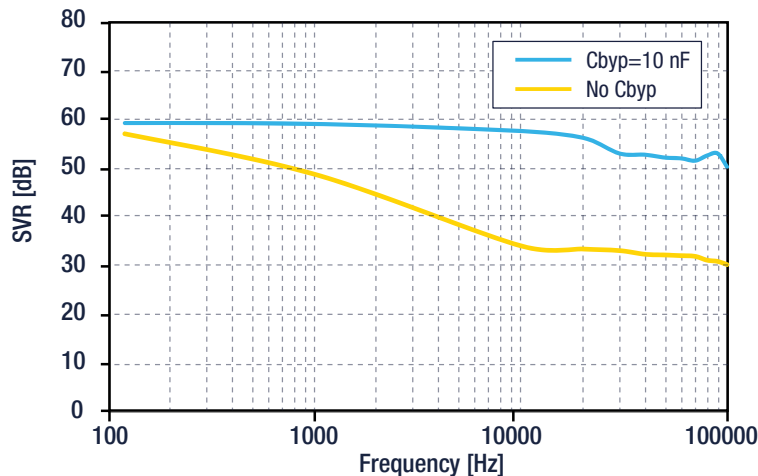

## LDK130 typical application diagram

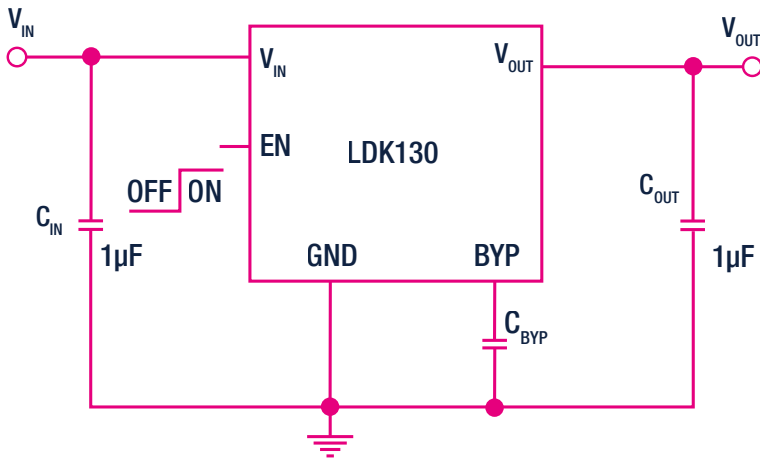

## Linear voltage regulators for post-regulation

Part number	Operating $V_{IN}$ (V)	AMR $V_{IN}$ (V)	$V_{OUT}$ (V)	$I_{OUT}$ (A)	Dropout voltage	$I_q$ ( $\mu$ A)	PSRR @1 kHz (dB)	Output noise 10 Hz-100 kHz ( $\mu$ V)	Other features	Package
<b>LDK130</b>	1.9 to 5.5	7	Fixed (1.1, 1.5, 1.8, 2.2, 2.8, 3.3)	0.3	100 mV at 100 mA	30	60	50	Enable, bypass for NR, OC and thermal protection	SOT23-5L
<b>LD39100</b>	1.5 to 5.5	7	Adj. (0.8 to 4.5) Fixed (1.2, 1.8, 2.5, 3.3)	1	200 mV at 1 A	20	70	30	Enable, PGOOD, OC and thermal protection	DFN6 (3x3 WF)
<b>LD49100</b>	1.5 to 5.5	7	Adj. (0.8 to 4.5) Fixed (1.0, 1.2, 1.8, 2.5, 3.3)	1	200 mV at 1 A	20	70	30	Enable, PGOOD, soft-start, remote sensing, OC and thermal protection	DFN6 (3x3 WF)
<b>LD59150</b>	$V_{IN}$ 0.8 to 5.5, $V_{bias}$ 2.7 to 5.5	6	Adj. (0.8 to 3.6)	1.5	65 mV at 1.5 A	880	70	25	Bias pin, Enable, program. soft-start, PGOOD, OC and thermal protection	DFN10 (3x3 WF)

# LED / OLED Drivers

## SWITCHING LED DRIVERS

### ALED6000: automotive 3 A single channel LED driver with integrated DC-DC converter

The **ALED6000** is a monolithic step-down switching regulator designed to deliver up to 3 A of DC current for driving high-power LEDs. Its wide input voltage range makes it an excellent choice for automotive applications.

The adjustable current limit allows selecting the inductor RMS current in accordance with the nominal output LED current, while the switching frequency can be tuned to enable a more compact application design. Pulse-by-pulse current sensing, enhanced by digital frequency scaling, provides reliable constant current protection across various operating conditions. The integrated switch-over functionality on the VBIAS pin optimizes efficiency. Additionally, multiple devices can be synchronized via the SYNCH pin to eliminate beating noise in low-noise environments and to reduce the RMS value of the input current.



### MAIN FEATURES

- AEC-Q100 qualified
- Operating supply voltage range 4.5 V – 60 V
- Single channel LED driver with integrated DC-DC converter
- Max. output LED current 3 A
- Supported topologies: buck, positive/inverting buck-boost and floating boost
- Adjustable  $F_{sw}$  (250 kHz – 1.5 MHz)
- Adjustable soft-start time
- Digital dimming capability
- Enable and dimming dedicated pins
- Adjustable current limitation
- Very low shutdown current:  $I_o < 11 \mu A$
- $\pm 3\%$  LED output current reference accuracy
- OCP and auto-recovery thermal shutdown
- SYNCH pin for multi-device applications
- Package: HTSSOP16

## ALED6000 application circuit

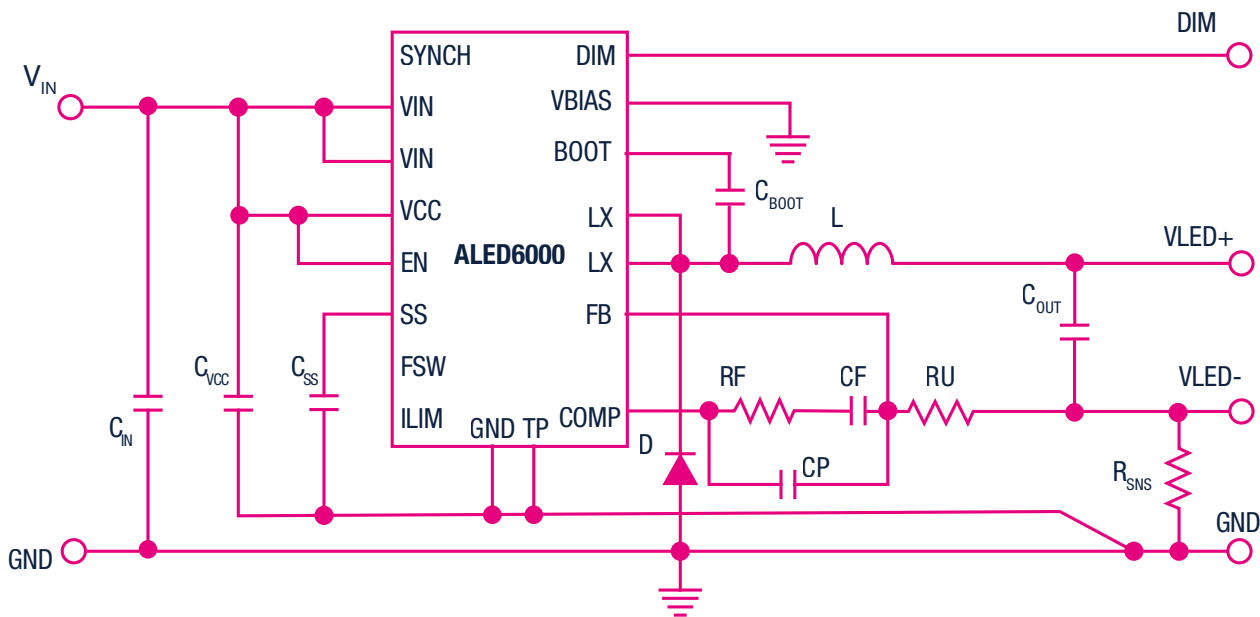

## Switching LED drivers

Part number	V <sub>in</sub> (V)	Channels	I <sub>LED_MAX_CH</sub> (A)	V <sub>LED_MAX_CH</sub> (V)	Supported topology	Special features	Package
ALED6000	4.5 to 60	1	3	60	Buck	Adjustable f <sub>sw</sub> (250 kHz - 1.5 MHz), OC and thermal protection with auto recovery, adjustable soft-start time, dimming function with dedicated pin, adjustable current limitation, external synchronization for multi-device applications, very low shutdown current (10 μA typ.), 3% output current accuracy over temperature	HTSSOP16
ALED6001	5.5 to 36	1	I <sub>ex_mosfet</sub>	60	Boost/ SEPIC/ floating Buck-boost	Adjustable f <sub>sw</sub> (100 kHz - 1 MHz), PWM-dimming, very low shutdown current: I <sub>SHDN</sub> < 10 μA, external synchronization for multi-device applications, overcurrent protection, thermal shutdown with auto restart, output short detection, LED constant current control loop	HTSSOP16

## Switching LED drivers evaluation boards

Part number	Description	Documentation
STEVAL-ILL072V1	Single-channel, 1 A LED driver with boost controller for interior/exterior lights based on the ALED6001	DB2608
STEVAL-ILL089V1	1 A buck LED driver board based on the ALED6000 automotive-grade dimmable LED driver	DB4070

## Switching LED drivers application examples



Front lighting  
(daily running light, high/low beam light)

ALED6000, ALED6001

## LINEAR LED DRIVERS

### LDLL16EN: 16-channel linear LED driver with CAN FD light interface

The **LDLL16EN** is a monolithic 16-channel LED driver designed for automotive exterior and interior LED lighting applications.

It supports output voltages up to 20 V, enabling multiple LEDs to be connected in series. The device features 16 regulated current sink channels, each programmable to deliver currents ranging from 6.3 mA to 100 mA for precise LED control. The LDLL16EN integrates a robust CAN FD light-compatible serial communication interface, supporting high-speed data transmission up to 1 Mbit/s and utilizing the CAN FD protocol for extended frame lengths. It includes an internal protocol handler, eliminating the need for additional external components to manage communication with the master ECU. Additionally, it provides a shared RX/TX interface for connection with an external transceiver, supporting up to six devices on the same bus. The device can operate either in bus mode via the CAN FD light-compatible interface or in standalone/ fail-safe mode using internal few-time programmable (FTP) memory registers.

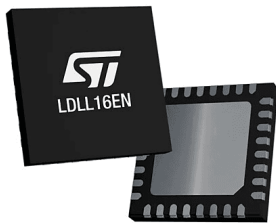

#### MAIN FEATURES

- AEC-Q100 qualified
- Basic information to support functional safety application available
- Supply voltage 5 to 28 V (40 V AMR)
- CAN FD light-compatible serial interface
- RX/TX interface
- Timeout watchdog with fail-safe operation
- Low standby current
- Standalone and bus mode operation
- Embedded non-volatile and volatile memories
- 16 low-side constant current output channels
- Iout\_max for channel 100 mA (parallelable outputs)
- Output voltage up to 20 V
- Current setting per channel by 8-bit DAC
- Analogue and PWM dimming
- Optimized turn-on/off time, gradual outputs delay and dithered clock
- Integrated 8-bit ADC for diagnostic
- 1 dedicated line for fault bus
- Temperature warning (one threshold)
- Overtemperature shutdown
- Short-circuit and open-load detection and protection
- Automatic LED current derating
- Package: QFN32 (5x5)

## LDLL16EN typical application

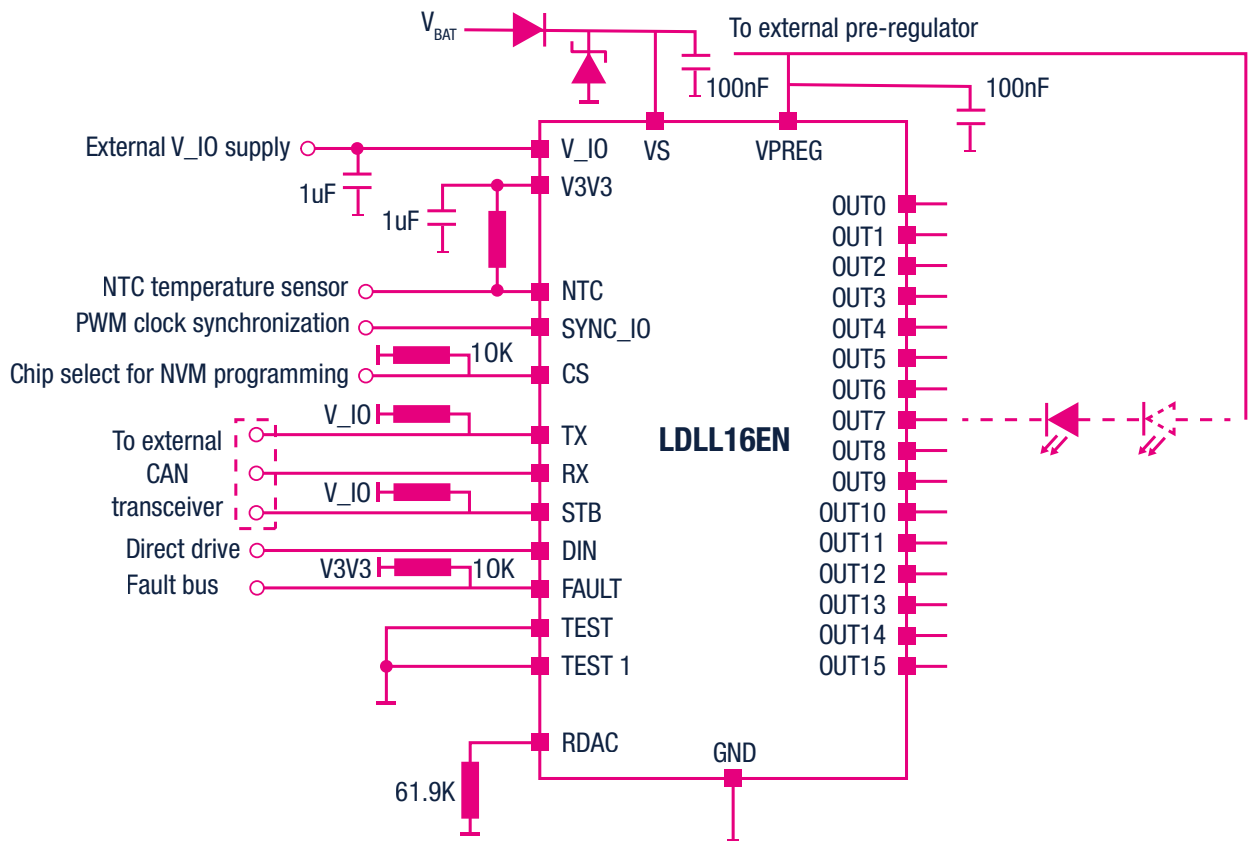

## ALED7709: 4-channel linear LED driver with integrated boost/SEPIC controller

The **ALED7709** is an automotive-grade LED driver (AEC-Q100 Grade 1 qualified) that integrates a boost/SEPIC controller with four low-side constant-current sink channels. It is designed to drive strings of high-brightness LEDs efficiently. The switching converter section provides the supply rail for the LED strings, continuously optimizing the voltage for maximum efficiency. The boost/SEPIC controller supports external synchronization and spread spectrum modulation.

Two versions are available: the ALED7709A, which operates in bus-driven mode (BDM) via an I2C serial interface, and the ALED7709B, which functions in standalone mode (SAM) controlled solely by a PWM signal. The device also supports an optional P-channel MOSFET in series with the input. This MOSFET protects the system, LED strings, and channels from fault conditions such as output short-to-ground or excessive input voltage transients, while also reducing power consumption during standby.



### MAIN FEATURES

- AEC-Q100 qualified
- Basic information to support functional safety application available
- Supply voltage 4.5 to 42 V (60 V load dump)
- 4 x 40 V rated constant current outputs
- Adjustable up to 200 mA per channel
- $\pm 2\%$  typ. output current accuracy
- Mixed PWM and analog dimming
- 100 Hz to 12.8 kHz dimming frequency
- Dimming ratio 10000:1 at 100 Hz
- Simultaneous or exclusive control by PWM and I2C interface
- Low shutdown current:  $I_{SHDN} < 15 \mu A$
- Current setting per channel by 8-bit DAC
- Fixed frequency peak current-mode controller
- Cycle-by-cycle power switch OCP
- Adj.  $f_{sw}$  (250 kHz to 2.2 MHz) with optional spread spectrum
- Synchronized boost and SEPIC topology support
- Line switch control for standby power saving and inrush current protection
- Input overvoltage and output short-circuit protection
- Package: QFN24 WF (5x5 mm)

# ALED7709 typical application circuit

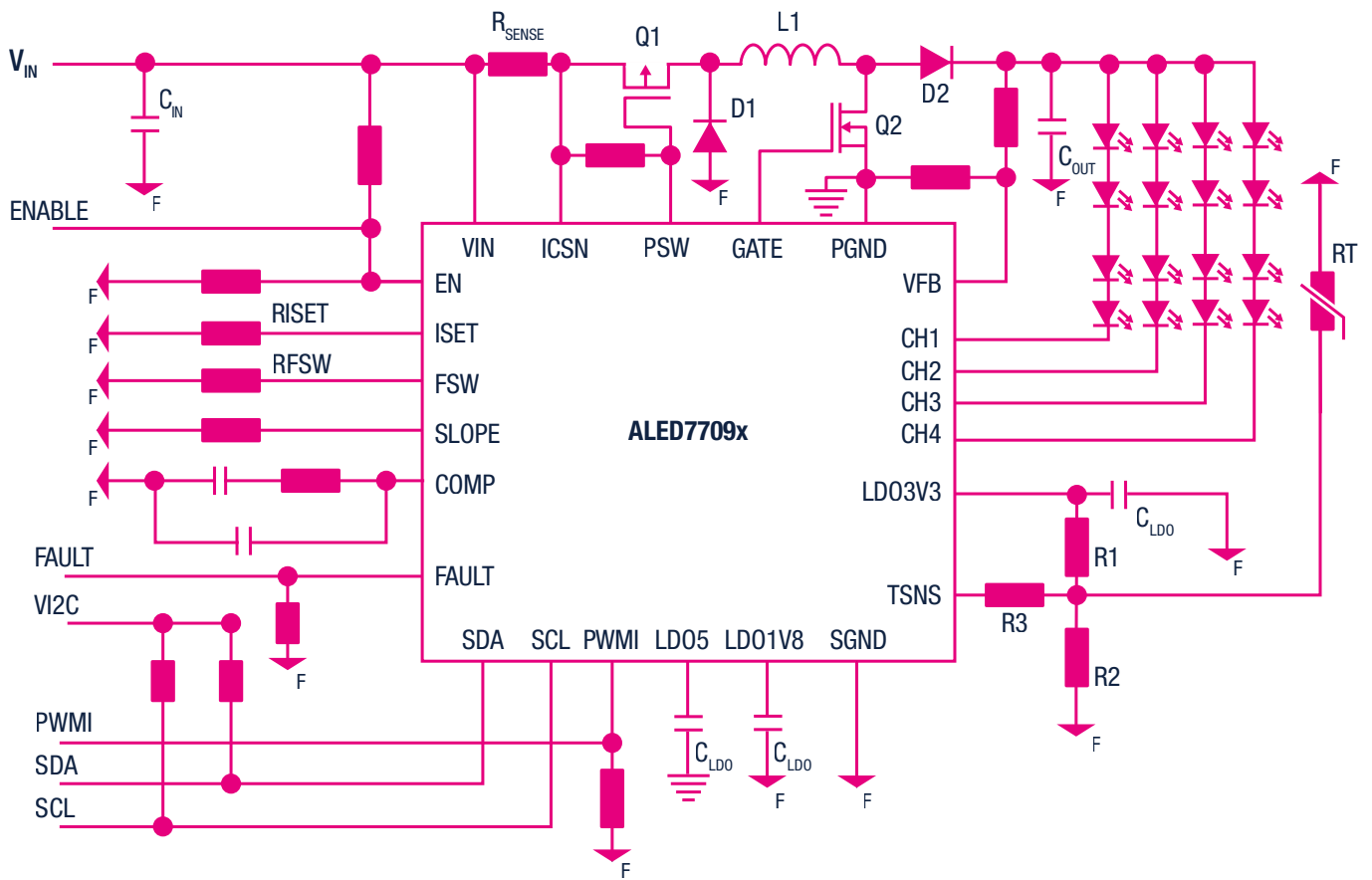

## Linear LED drivers

Part number	Channels	$I_{LED\_MAX\_CH}$ (mA)	$V_{IN}$ (V)	$V_{OUT\_MAX}$ (V)	Special features	Power stage	Package
ALED7709	4	200	4 to 42	40	Adjustable $f_{sw}$ (250 kHz – 2.2 MHz ) with optional spread spectrum, mixed PWM and analog dimming, selectable channels phase-shifting and adjustable rise/fall time for reducing EMI, cycle-by-cycle power switch OCP, input OVP and output SCP, thermal shutdown LED failure (open and short-circuit) detection	Boost and SEPIC	QFN24 (5x5 WF)
ALED7707	6	85	4.5 to 36	36	Adjustable $f_{sw}$ (250 kHz – 1 MHz) external synchronization for multidevice applications, pulse skip power-saving mode at light load, programmable soft-start, programmable OVP protection, thermal shutdown, row disable option, less than 10 $\mu$ s (min.) dimming on-time, 3% current matching between rows, LED failure (open and short-circuit) detection	Boost	QFN24 (5x5 WF)
ALED8102S	8	100	3 to 5.5	20	8 constant current output channels driven by 4 input control pins for local dimming, output enable input for global dimming, adjustable output current through external resistor	-	HTSSOP16
STAP08DP05	8	100	3 to 5.5	20	Short and open output error detection, thermal shutdown protection, adjustable output current through external resistor, serial data IN/ parallel data OUT	-	HTSSOP16
ALED1262ZT	12	60	5.5 to 38	19	LEDs OPEN detection, 7-bit local dimming brightness control, I <sup>2</sup> C interface bus-driven or standalone operation mode, custom configuration by OTP with redundancy and ECC	-	HTSSOP24
LDLL16EN	16	100	5 to 28	20	Bus mode through integrated serial interface “CAN FD light», standalone mode through integrated NVM, analogue and PWM dimming, integrated 8-bit ADC - for full and flexible diagnostic, automatic LED current derating, OT warning/shutdown, short-circuit and open-load detection and protection	-	QFN32L (5x5)
ALED1642GW	16	40	3 to 5.5	20	7-bit global current gain programmability, 12/16-bit local PWM grayscale brightness control, current setting through external resistor, programmable turn on/off, auto wake-up mode, error detection mode (both open and shorted-LEDs)	-	HTSSOP24

## Linear LED drivers evaluation boards

Part number	Description	Documentation
STEVAL-LLL014V1	Automotive LED driver 4-channel evaluation kit based on the ALED7709	UM3180
STEVAL-ILL067V1	6-channel ALED7707-based LED driver with embedded boost converter for automotive interior lighting and TFT backlighting	DB2607
STEVAL-LLL002V1	LED driver for automotive rear lights with animations based on ALED1262 and STM8A	DB3472
STEVAL-ILL073V1	RGB LED driver for automotive lighting based on ALED1642GW and STM8A	UM2017
STEVAL-ILL090V1	Evaluation kit based on the ALED8102S (8-channel LED driver with direct switch control)	DB4309

## Linear LED drivers application examples

				
Grill front lighting	Rear lighting	Ambient/interior lighting	Cluster backlighting	Head-up display
LDLL16EN	LDLL16EN, ALED1262ZT, STAP08DP05, ALED8102S	ALED1642GW, ALED7709, ALED7707		ALED7709

## LINEAR OLED DRIVERS

### L99LDLH32: 32-channel OLED driver with CAN FD light interface

The **L99LDLH32** is a monolithic 32-channel linear current regulator specifically designed for automotive OLED rear lighting applications. The L99LDLH32 addresses the automotive industry's new efficiency challenges with its low standby current absorption achieved with all-channel switchoff.

The device offers a wide range of configurability options, including the ability to operate in standalone, fail-safe, and bus modes, as well as the integration of both volatile and nonvolatile memories. The CAN FD light interface allows an easy integration of the device into the vehicle's architecture, making it an attractive option for automotive manufacturers. It also features an integrated 8-bit ADC, which enables full and flexible diagnostic capabilities. In addition, there is one dedicated line, which is connected to a physical pin for fault bus, allowing for various kinds of fault diagnostics on the OLEDs at the output channels. These channels can be put in parallel to address a higher current than the programmable one. For each channel, the current can be individually programmed by using an integrated 8-bit DAC.



#### MAIN FEATURES

- AEC-Q100 qualified
- Basic information to support functional safety application available
- Supply voltage 5.5 to 28 V (40 V AMR)
- CAN FD light compatible serial interface
- Integrated 8-bit ADC for full and flexible diagnostic
- Current setting per channel
- Standalone, fail-safe and bus mode operations
- Embedded volatile and non-volatile memories
- 32 high-side constant current output channels
- Output current from 1 mA to 15 mA (parallelable outputs)
- Output voltage up to 35 V
- Analog and PWM dimming
- Slow turn-on/off time, gradual outputs delay and dithered clock for better EMC performance
- Integrated 8-bit ADC
- Dedicated line for fault bus
- Automatic LED current derating
- Short-circuit and open load detection and protection
- Package: QFN48 (7x7)

### Linear OLED drivers

Part number	Channels	$I_{LED\_MAX\_CH}$ (mA)	$V_{OUT\_MAX\_CH}$ (V)	$V_{IN}$ (V)	Package
L99LDLH32	32	15	35	5 to 40	QFN48 (7x7)

## L99LDLH32 application diagram

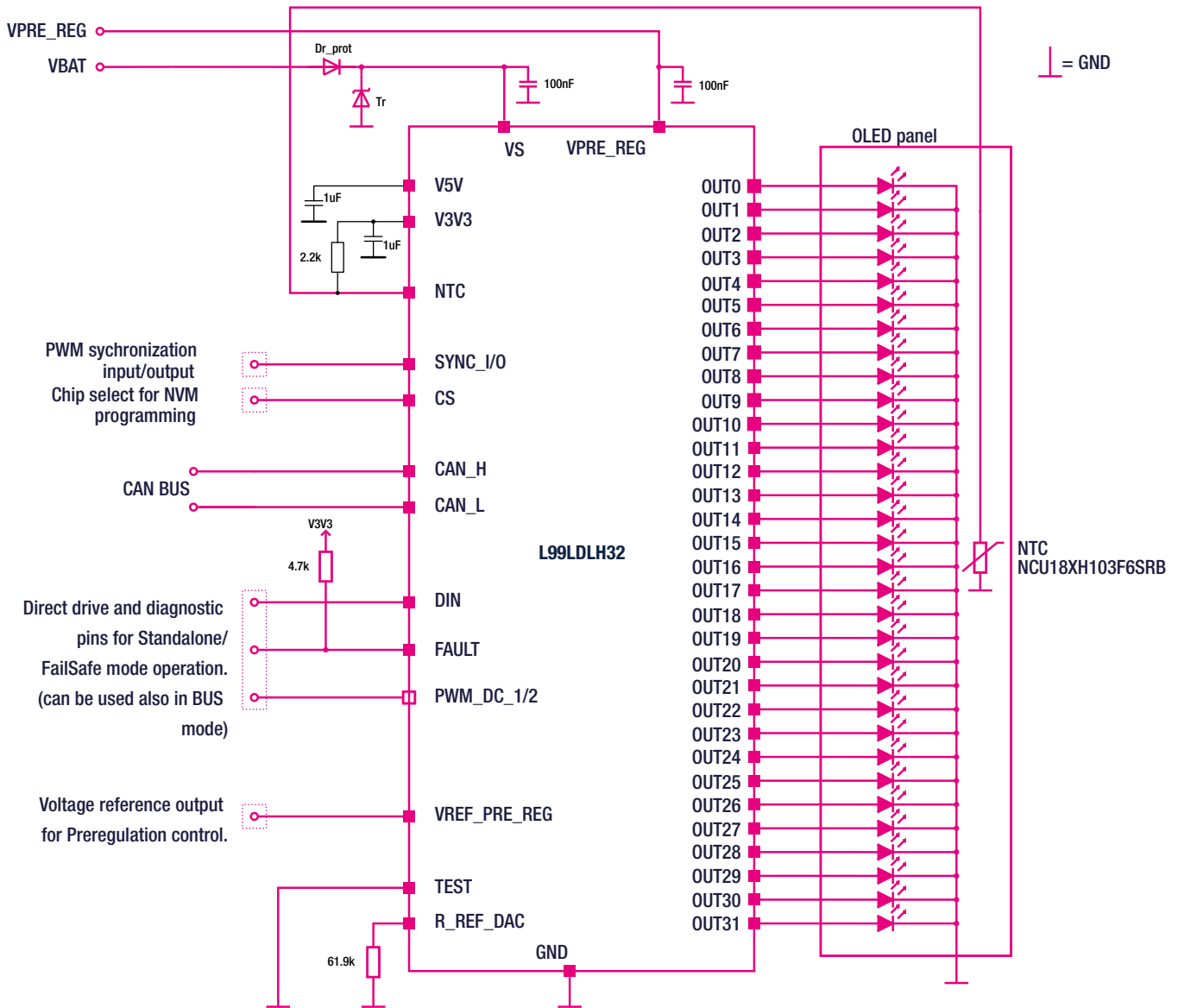

## Linear OLED driver applications examples



## Linear OLED evaluation boards

Part number	Description	Documentation
EV-L99LDLH32G	L99LDLH32 evaluation board	AN5803, AN5712, UM2996

# Operational amplifiers & Comparators

## LOW-POWER OPERATIONAL AMPLIFIERS

**TSU111Y/112Y: nanopower (920 nA), high accuracy (150  $\mu$ V), 5 V CMOS operational amplifier**

The **TSU111Y** and **TSU112Y** operational amplifiers (op amps) feature ultra-low power consumption, with a typical current of 920 nA per channel and a maximum of 1.3  $\mu$ A when powered at 3.3 V. Their wide supply voltage range from 1.5 V to 5.5 V enables efficient operation from coin-type lithium batteries or regulated power supplies in low-power applications. With a maximum input offset voltage of 150  $\mu$ V and a gain bandwidth of 9 kHz, the TSU111Y and TSU112Y are well-suited for sensor signal conditioning, battery management systems, on-board chargers (OBC), and wireless charging solutions.



### MAIN FEATURES

- AEC-Q100 qualified
- Nano power consumption: 920 nA
- Low offset voltage 150  $\mu$ V max. at 25°C
- Supply voltage: 1.5 to 5.5 V
- Rail-to-rail input and output
- Gain bandwidth product: 9 kHz
- Low input bias current: 10 nA (max.)
- High tolerance to ESD: 4 kV (HBM)
- Packages: SOT23-5L/SC70-5 (single), MiniSO8/DFN8(2x2 WF) (dual)

Supply current vs. supply voltage at high VICM

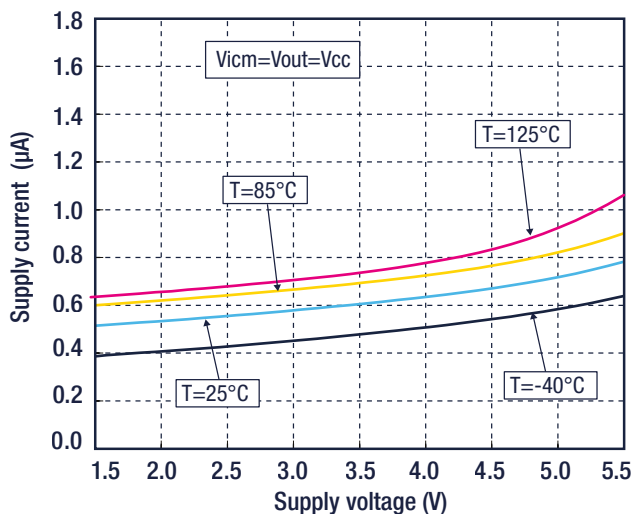

Input offset voltage vs. temperature at 3.3V

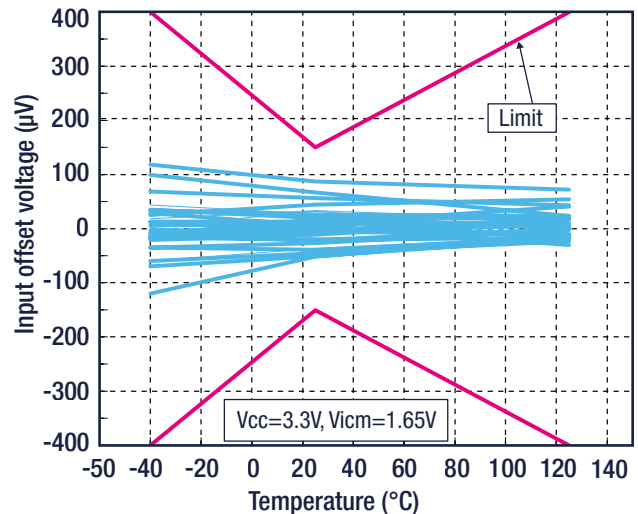

## Low power operational amplifiers

Part number	Typ. $I_{CC}$ per channel ( $\mu$ A)	Min. $V_{CC}$ (V)	Max. $V_{CC}$ (V)	Typ. GBP (MHz)	Typ. SR (V/ $\mu$ s)	Max. $V_{IO}$ @ 25 °C ( $\mu$ V)	Typ. $I_{OUT}$ (mA)	Rail-to-rail		Package		
								In	Out	Single	Dual	Quad
TSU1111Y/21Y	0.920	1.5	5.5	0.009	0.0017	150	41	Yes	Yes	SOT23-5 SC70-5	MiniS08, DFN8 (2x2 WF)	NA
TS934	20	2.7	10	0.1	0.05	10 000	5	No	Yes	NA	NA	S014
TSZ121/2/4	31	1.8	5.5	0.4	0.19	5	17	Yes	Yes	SOT23-5	S08, MiniS08	TSSOP14
TSV521A/2A/4A	45	2.7	5.5	1.15	0.89	600	55	Yes	Yes		MiniS08	
TSX631A/2A/4A	45	3.3	16	0.2	0.12	500	90	Yes	Yes		MiniS08	
TSV631/2/4	60	1.5	5.5	0.88	0.34	500	69	Yes	Yes		S08	
TSB611/2	103	2.7	36	0.56	0.18	1 000	60	No	Yes		S08, MiniS08	NA
TSV851A/2A/4A	180	2.3	5.5	1.3	0.7	800	70	No	Yes		S08, MiniS08	TSSOP14
TSZ151/2	210	1.8	5.5	1.6	0.8	7	30	Yes	Yes		SOT23-5 SC70-5	S08, MiniS08 DFN8 (2x2 WF)
TSX561A/2A/4A	250	3	16	0.9	1.1	600	90	Yes	Yes	SOT23-5	MiniS08	TSSOP14
TSB621/2/4	310	2.7	36	1.7	0.6	1 000	45	No	Yes	SOT23-5	DFN8 (3X3 WF), S08, MiniS08	S014, TSSOP14
TSB571/2	380	4.0	36.0	2.5	0.88	1 500	65	Yes	Yes	SOT23-5	MiniS08, DFN8 (3x3 WF)	NA
TS912B/14A	400	2.7	16	1.4	1	2 000	70	Yes	Yes	NA	S08	S014
TS1871A/2A/4A	400	1.8	6	1.8	0.6	1 000	72	Yes	Yes	SOT23-5	S08, TSSOP8	S014, TSSOP14
TSV321A/358A/324A	500	2.5	6	1.4	0.6	1 000	80	Yes	Yes		S08, TSSOP8	S014, TSSOP14
TS512A	500	6	30	3	1.5	500	23	No	No	NA	S08	NA
TS321	600	3	30	0.8	0.4	2 000	40	No	No	SOT23-5	NA	NA
TSX711A/12	660	2.7	16	2.7	1.2	100	54	Yes	Yes		S08, MiniS08	
TSX7191A/92	660	2.7	16	8.5	2.4	100	70	Yes	Yes			
TSZ181/2	700	2.2	5.5	3	4.7	25	27	Yes	Yes	SOT23-5, S08	S08, MiniS08	S014, TSSOP14
TSV911A/2A/4A	780	2.5	5.5	8	4.5	1 500	35	Yes	Yes		NA	
TS507	850	2.7	5.5	1.9	0.6	100	115	Yes	Yes	SOT23-5	NA	
TS9222/9224	900	2.7	12	4	1.3	500	80	Yes	Yes	NA	S08, TSSOP8	S014, TSSOP14
TS951/2/4	950	2.7	12	3	1	6 000	22	Yes	Yes	SOT23-5	S08, MiniS08	S014, TSSOP14

# PRECISION OPERATIONAL AMPLIFIERS

**TSB181/2: very high accuracy (20  $\mu$ V) zero-drift, rail-to rail output, 3 MHz, 36 V op amp**

The **TSB181** and **TSB182** are high-precision operational amplifiers featuring a maximum input offset voltage of 20  $\mu$ V. They support a wide supply voltage range and provide rail-to-rail output capability. These amplifiers deliver an excellent balance between speed and power consumption, with a gain bandwidth product of 3 MHz while typically drawing 650  $\mu$ A per amplifier across the broad supply voltage range.



Input offset voltage vs. temperature for  $V_{cc} = 36$  V

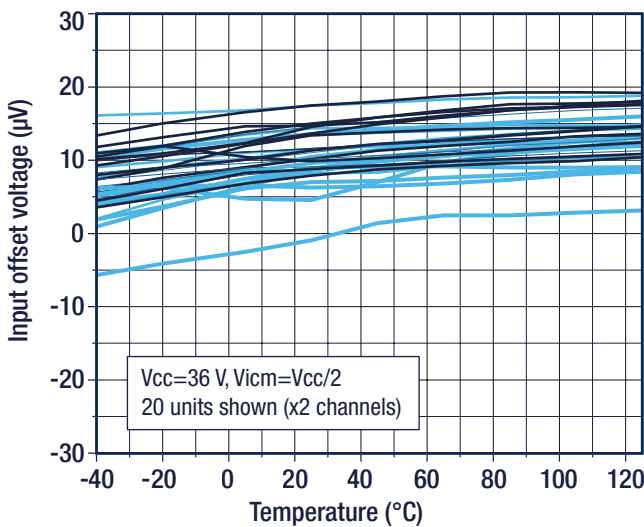

## MAIN FEATURES

- AEC-Q100 qualified
- Wide supply voltage: 4 to 36 V
- Very low offset voltage: 20  $\mu$ V max.
- Slew rate: 2 V/ $\mu$ s
- Gain bandwidth product: 3 MHz
- Rail-to-rail output
- High ESD tolerance: 4 kV HBM
- Packages: S08/SOT23-5 (single), MiniS08/S08 (dual)



Slew rate vs. input common mode voltage at  $V_{cc}=5$  V

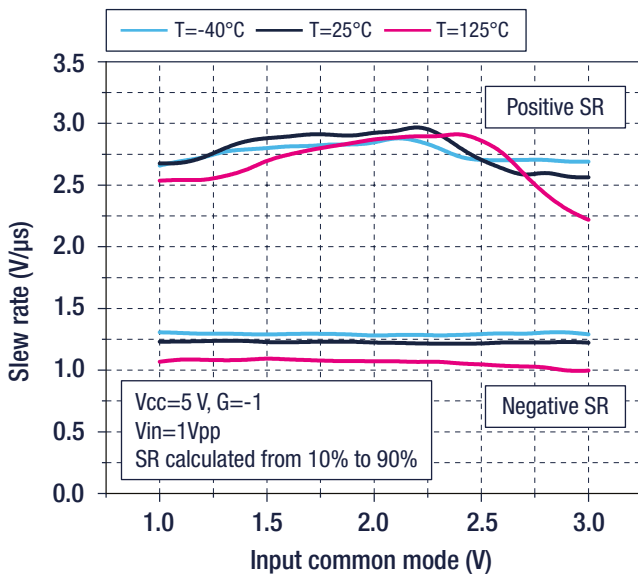

**TSZ901: very high accuracy (5  $\mu\text{V}$ ) high bandwidth (10 MHz) zero-drift 5 V op amp**

The **TSZ901** is a single operational amplifier characterized by extremely low offset voltages with virtually no drift across temperature variations. It provides rail-to-rail input and output, an excellent speed-to-power consumption ratio, and a gain bandwidth product of 10 MHz, while drawing only 1.5 mA at 5 V supply. Additionally, the TSZ901 features ultra-low input bias current, making it an ideal choice for high-accuracy sensor interface applications.



Input offset voltage vs. temperature at  $V_{CC} = 5\text{ V}$

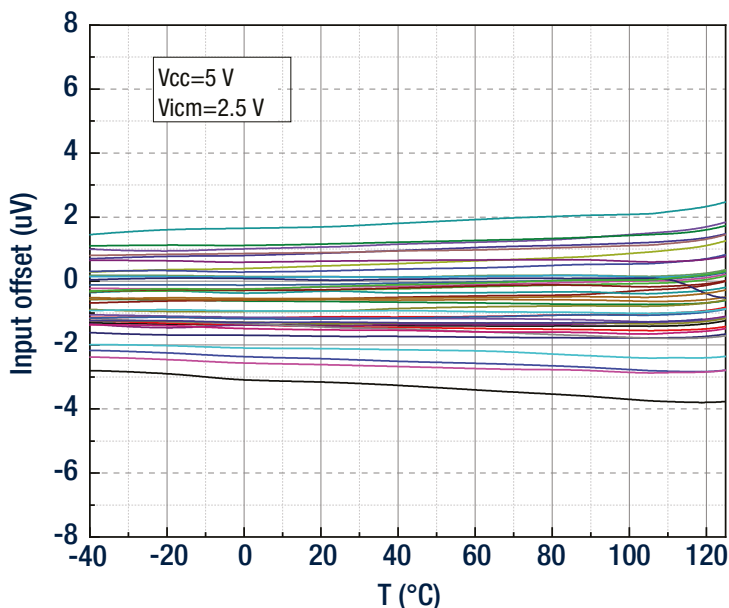

**MAIN FEATURES**

- AEC-Q100 qualified
- Very high accuracy and stability
  - $V_{io} = 5\ \mu\text{V}$  max. at  $25^\circ\text{C}$
  - $V_{io} = 8\ \mu\text{V}$  over the full temperature range ( $-40^\circ\text{C}$  to  $125^\circ\text{C}$ )
- Gain bandwidth product: 10 MHz
- Rail-to-rail input and output
- Low supply voltage: 2.5 to 5.5 V
- Low power consumption: 1.5 mA at 5 V
- Extended temperature range:  $-40$  to  $125^\circ\text{C}$
- Package: SOT23-5

Slew rate vs. temperature

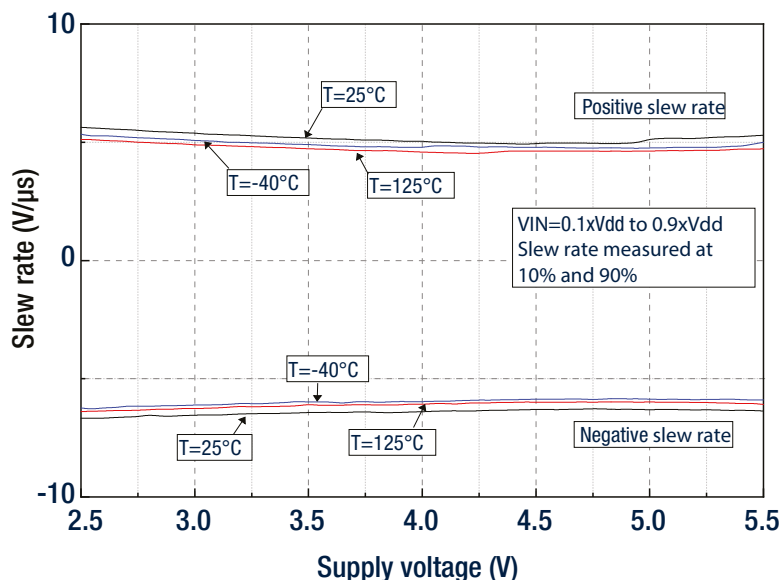

## Precision operational amplifiers

Part number	Max. $V_{IO}$ @ 25 °C ( $\mu$ V)	Typ. $V_{IO}$ drift ( $\mu$ V/°C)	Max. $I_{IB}$ @ 25 °C (pA)	Min. $V_{CC}$ (V)	Max. $V_{CC}$ (V)	Typ. GBP (MHz)	Typ. SR (V/ $\mu$ s)	Typ. $I_{CC}$ per channel (mA)	Typ. 1kHz noise (nV/ $\sqrt$ Hz)	Rail-to-rail		Package		
										In	Out	Single	Dual	Quad
TSZ121/2/4	5	0.01	200	1.8	5.5	0.4	0.19	0.031	37	Yes	Yes	SOT23-5, SC70-5	S08, MiniS08	TSSOP14
TSZ901	5	0.01	200	2.5	5.5	10	6	1.5	9	Yes	Yes	SOT23-5	NA	NA
TSZ151/2	7	0.036	200	1.8	5.5	1.6	0.8	210	27	Yes	Yes	SOT23-5 SC70-5	S08, DFN8, MiniS08	NA
TSB181/2	20	0.03	400	4	36	3	2	650	27	No	Yes	S08 SOT23-5	S08, MiniS08	NA
TSZ181/2	25	0.01	200	2.2	5.5	3	4.7	0.7	37	Yes	Yes	SOT23-5		NA
TSX711A/12	100	0.8	50	2.7	16	2.7	1.2	0.66	22	Yes	Yes			
TS507	100	1	70 000	2.7	5.5	1.9	0.6	0.85	12	Yes	Yes			
TSX7191A/2	100	0.8	50	2.7	16	8.5	2.4	0.66	22	Yes	Yes		S08, MiniS08	
TSU1111Y/21Y	150	0.5	10	1.5	5.5	0.012	0.0017	0.001	200	Yes	Yes	SOT23-5, SC70-5	DFN8, MiniS08	NA
TSV7721/2	200	1.7	300	1.8	5.5	22	11	1.7	7	No	Yes	SOT23-5	S08, MiniS08	NA
TSV771/2/4	200	1.7	300	2.0	5.5	20	13	1.9	7	Yes	Yes	SOT23-5	S08, MiniS08	QFN16, TSSOP14
TSV781/2	200	1.7	300	2.0	5.5	30	19	3.3	14	Yes	Yes	SOT23-5	S08, MiniS08	NA
TSV791/2/4	200	1.7	300	2.2	5.5	50	30	5.5	6.5	Yes	Yes	SOT23-5	S08, MiniS08	S014, TSSOP14
TSB711A/12A	300	2.8	300 000	2.7	36.0	6.0	3.00	1.800	12	Yes	Yes	SOT23-5	S08, MiniS08	NA
TSB7191A/92A	300	2.8	300 000	2.7	36.0	22	12.0	1.8	12	Yes	Yes			NA
TSV631A/2A/4A	500	2	10	1.5	5.5	0.88	0.34	0.06	60	Yes	Yes	SOT23-5	S08	TSSOP14
TS9222/4	500	2	55 000	2.7	12	4	1.3	0.9	9	Yes	Yes	NA	S08, TSSOP8	S014, TSSOP14
TS512A/4A	500	2	150 000	6	30	3	1.5	0.5	8	No	No	NA	S08	NA
TSX561A/2A/4A	600	2	100	3	16	0.9	1.1	0.25	48	Yes	Yes	SOT23-5	MiniS08	TSSOP14
TSX631A/2A/4A	700	1	100	3.3	16	0.2	0.12	0.045	60	Yes	Yes			
TS9511	800	2	70 000	2.7	12	3	1	0.95	25	Yes	Yes		NA	
TSV851A/2A/4A	800	1	60 000	2.3	5.5	1.3	0.7	0.13	30	No	Yes		S08, MiniS08	TSSOP14
LMV821A/2A/4A	800	1	120 000	2.5	5.5	5.5	1.9	0.4	16	No	Yes		S08, TSSOP8	S014, TSSOP14

## HIGH OUTPUT CURRENT OPERATIONAL AMPLIFIERS

### TSB582: high output current 36 V, 3.1 MHz with thermal shutdown and current limiter

The **TSB582** is a high performance dual operational amplifier featuring high supply voltages and high output current capability while being protected through internal current limiting and thermal shutdown. Enhanced ESD and RF immunity facilitate the use in harsh automotive environments. The two high output current amplifiers of the TSB582 allow for driving loads directly in bridge tied mode or, connected in parallel, make it possible to double the output sink/source current. Additionally, the TSB582 is available in the two space-saving packages SO8 with exposed pad and DFN8 with wettable flanks.



### Output current vs. output voltage and temperature

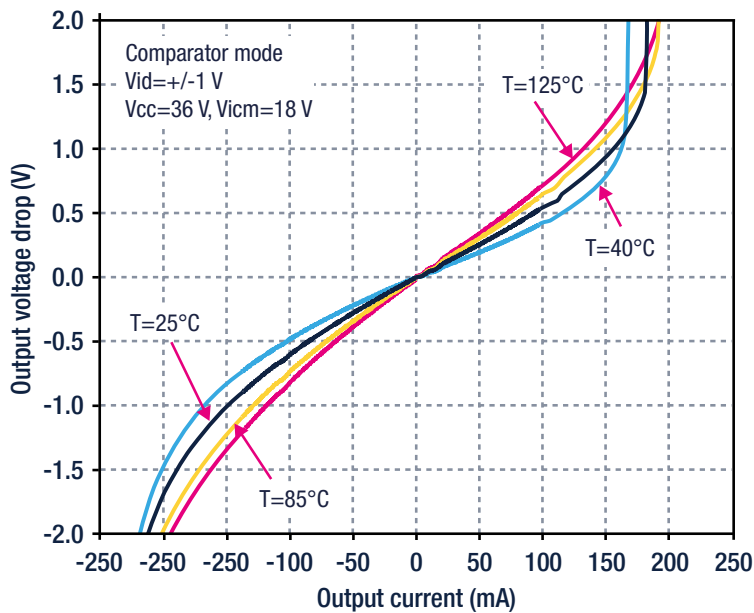

### Input offset distribution

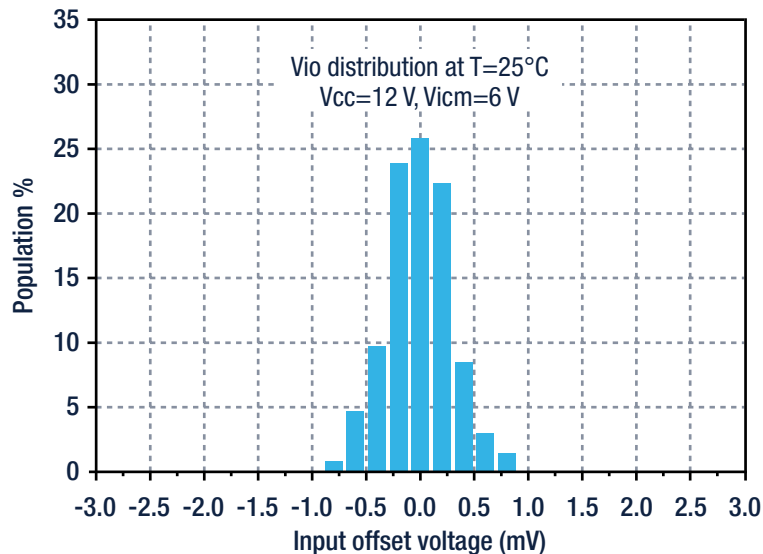

### MAIN FEATURES

- AEC-Q100 qualified
- Wide supply voltage 4 V to 36 V
- High output current 2 x 200 mA
- Gain bandwidth product: 3.1 MHz
- Rail-to-rail output, low rail input
- Internal thermal shutdown and output current limiter
- High tolerance to ESD: 4 kV HBM
- Enhanced RF noise immunity
- Extended temperature range: -40°C to 125°C
- Package: DFN8, SO8

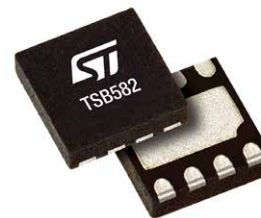

## High output current operational amplifiers

Part number	Typ. $I_{OUT}$ (mA)	Min. $V_{CC}$ (V)	Max. $V_{CC}$ (V)	Typ. GBP (MHz)	Typ. SR (V/ $\mu$ s)	Typ. $I_{CC}$ per channel (mA)	Rail-to-rail		Package		
							In	Out	Single	Dual	Quad
TSV321A/358A/324A	80	2.5	6	1.4	0.6	0.5	Yes	Yes	SOT23-5	S08, TSSOP8	S014, TSSOP14
TS9222/4	80	2.7	12	4	1.3	0.9	Yes	Yes	NA	S08, TSSOP8	S014, TSSOP14
TS921/2/4	80	2.7	12	4	1.3	1	Yes	Yes	NA	S08, TSSOP8	S08, TSSOP14
TSX561A/2A/4A	90	3	16	0.9	1.1	0.25	Yes	Yes	SOT23-5	MiniS08	TSSOP14
TSX631A/2A/4A	90	3.3	16	0.2	0.12	0.045	Yes	Yes			TSSOP14
TS507	115	2.7	5.5	1.9	0.6	0.85	Yes	Yes		NA	
TS982	200	2.5	5.5	2.2	0.7	5.5	Yes	Yes	NA	S08	NA
TSB582	200	4.0	36	3.1	2.0	2.4	No	Yes	NA	DFN8 (3x3 WF), S08	NA

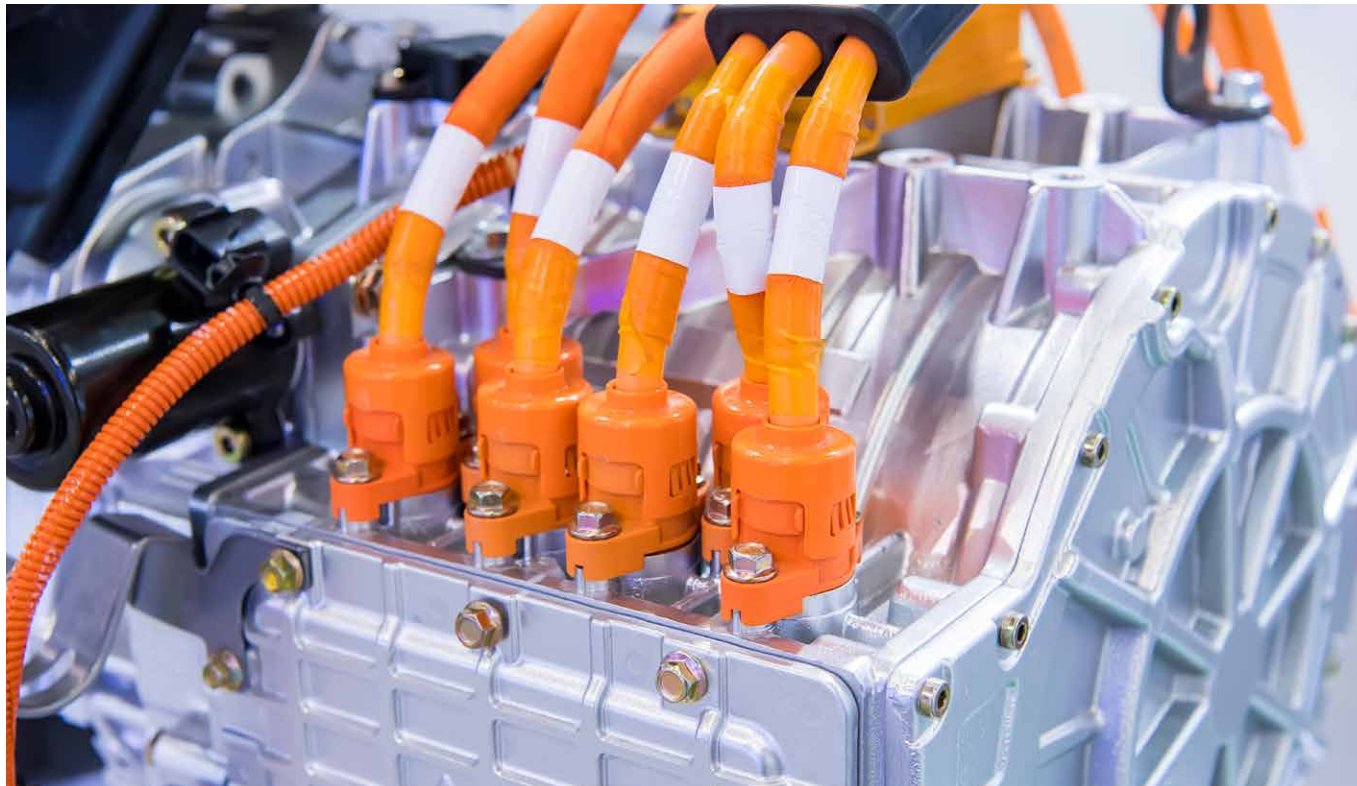

## HIGH BANDWIDTH OPERATIONAL AMPLIFIERS

### TSB951/TSB952: high bandwidth (52 MHz) rail-to-rail output, 36 V

The **TSB951** and **TSB952** are high-speed operational amplifiers that support an extended supply voltage range and feature rail-to-rail output stages. They offer an excellent balance between speed and current consumption, boasting a gain bandwidth product of 52 MHz while drawing less than 3.3 mA per channel at a 36 V supply voltage.



### Open loop Bode diagram at $V_{cc}=5\text{ V}$

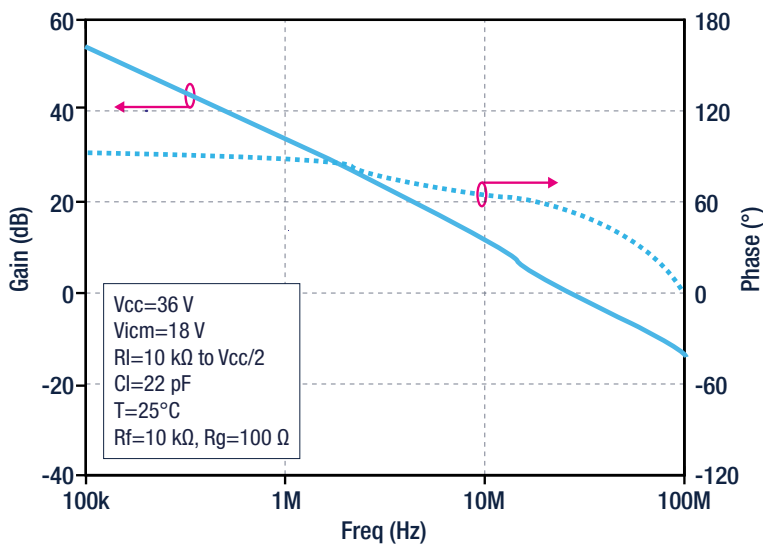

### MAIN FEATURES

- AEC-Q100 qualified
- Wide input voltage range: 4.5 to 36 V
- Gain bandwidth product 52 MHz
- Output current: 40 mA
- Low offset voltage: 3 mV
- Rail-to-rail output
- Extended temperature range:  $-40$  to  $+125^\circ\text{C}$
- Packages: S08/SOT23-5 (single), S08/DFN8 (dual)

### Slew rate vs $V_{cc}$

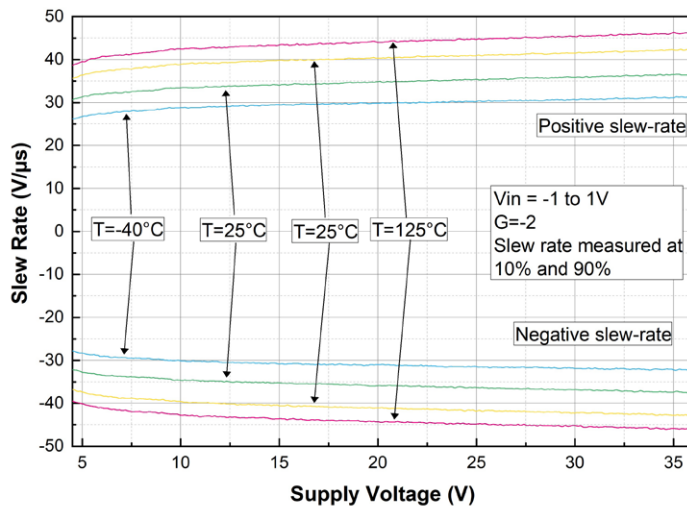

## High bandwidth operational amplifiers

Part number	Typ. GBP (MHz)	Typ. SR (V/ $\mu$ s)	Min. $V_{CC}$ (V)	Max. $V_{CC}$ (V)	Typ. $I_{CC}$ per channel (mA)	Max. $V_{IO}$ @25 °C ( $\mu$ V)	Typ. 1 kHz noise (nV/ $\sqrt$ Hz)	Typ. $I_{OUT}$ (mA)	Rail-to-rail		Package		
									In	Out	Single	Dual	Quad
TSB711A/12A	6	3	2.7	36	1.8	300	12	50	Yes	Yes	SOT23-5	S08, MiniS08	NA
TSB511/12/14	6	3	2.7	36	1.8	1500	12	50	Yes	Yes	SOT23-5	S08, MiniS08	S014, TSSOP14
TSV911A/2A/4A	8	4.5	2.5	5.5	0.78	1 500	27	35	Yes	Yes	SOT23-5, S08	S08, MiniS08	S014, TSSOP14
TSX7191/2	8.5	2.4	2.7	16	0.66	200	22	70	Yes	Yes	SOT23-5		NA
TSZ901	10	6	2.5	5.5	1.5	5	9	50	Yes	Yes	SOT23-5	NA	NA
TSX921/2	10	17.2	4	16	2.8	4 000	16.5	62	Yes	Yes	SOT23-5	S08, MiniS08	NA
TS971/2/4	12	4	2.7	10	2	5 000	4	100	No	Yes	SOT23-5	S08, TSSOP8, DFN8 (3x3)	TSSOP14
MC33078/9	15	7	5	30	2	2 000	4.5	30	No	No	NA	S08	S014
TSX9291/2	16	26	4	16	2.8	4 000	16.5	62	Yes	Yes	SOT23-5	S08, MiniS08	NA
TSV771/2/4	20	13	2.0	5.5	1.9	200	7	65	Yes	Yes	SOT23-5	S08, MiniS08	TSSOP14, QFN16
TSV991A/2A/4A	20	10	2.5	5.5	0.82	1 500	27	35	Yes	Yes	SOT23-5	S08, MiniS08	S014, TSSOP14
TSB7191A/92A	22	12	2.7	36	1.8	300	12	50	Yes	Yes	SOT23-5	S08, MiniS08	NA
TSV7721/2	22	11	1.8	5.5	1.7	200	13	65	No	Yes	SOT23-5	S08, MiniS08	NA
TSV781/2	30	19	2.5	5.5	3.3	200	14	65	Yes	Yes	SOT23-5	S08, MiniS08	NA
TSV791/2/4	50	30	2.2	5.5	5.5	200	6.5	60	Yes	Yes	SOT23-5	S08, MiniS08	S014, TSSOP14
TSB951/2	52	30	4.5	36	2.6	3000	16	40	No	Yes	SOT23-5, S08	S08, DFN8 (3x3 WF)	NA



## HIGH TEMPERATURE OPERATIONAL AMPLIFIERS

**TSZ181H/H1, TSZ182H/H1:** very high accuracy, high bandwidth (3 MHz), high temperature, zero-drift

The **TSZ181H/H1** and **TSZ182H/H1** series include single- and dual-channel operational amplifiers characterized by very good low offset voltage and minimal temperature-induced drift. These amplifiers feature rail-to-rail input and output stages, offering an outstanding balance between speed and current consumption. With a gain bandwidth product of 3 MHz, they operate efficiently at just 1 mA when powered at 5 V. Designed to function reliably across a broad temperature range from -40°C to 150/175°C (H/H1 version), they also exhibit extremely low input bias currents. Such attributes make these devices ideal for sensor interface applications requiring high precision and wide bandwidth within automotive environments.



Input offset voltage distribution at  $V_{CC} = 5\text{ V}$ ,  $T=175^\circ\text{C}$

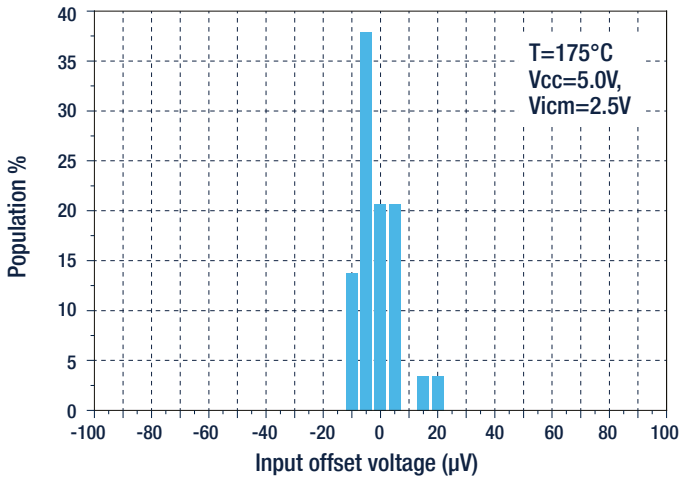

Input offset voltage vs temperature

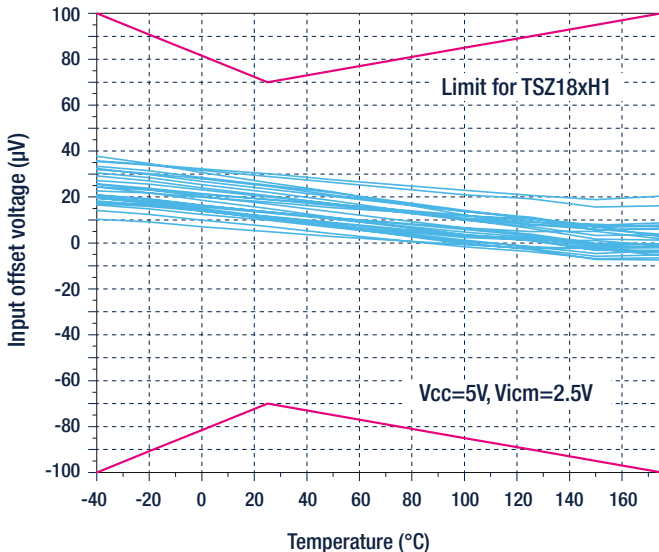

### MAIN FEATURES

- AEC-Q100 qualified
- Very high accuracy and stability
  - $V_{io} = 70\ \mu\text{V}$  max. at  $25^\circ\text{C}$  (H/H1 version)
  - $V_{io} = 44/100\ \mu\text{V}$  over full temperature (H/H1 version)
- Rail-to-rail input and output
- Low supply voltage: 2.2 to 5.5 V
- Low power consumption: 1 mA max. at 5 V
- Gain bandwidth product: 3 MHz
- Extended temperature range
  - -40 to 150/175°C (H/H1 version)
- Packages: SOT23-5 (single), SO8 (dual)



## High-temperature operational amplifiers

Part number	Max. operating Temperature (°C)	Typ. GBP (MHz)	Typ. SR (V/μs)	Min. V <sub>cc</sub> (V)	Max. V <sub>cc</sub> (V)	Typ. I <sub>cc</sub> per channel (mA)	Rail-to-rail		Package	
							In	Out	Single	Dual
LM2904AH/WH	150	1.1	0.6	3	30	0.5	GND	No	NA	TSSOP8, S08, Mini-S08
TSV912H	150	8	4.5	2.5	5.5	0.82	Yes	Yes	NA	S08
TSZ181H TSZ182H	150	3	4.7	2.2	5.5	0.70	Yes	Yes	SOT23-5	S08
TSZ181H1 TSZ182H1	175	3	4.7	2.2	5.5	0.70	Yes	Yes	SOT23-5	S08

## HIGH SPEED COMPARATORS

### TS3121/TS3121A/TS3121P: rail-to-rail, open-drain comparator with embedded power-on reset

The **TS3121** and **TS3121A**, **TS3121P** single comparators permit high-speed response time at low power consumption over specified supply voltage range of 1.7 V to 5.5 V. An embedded power-on reset circuit in the TS3121P version ensures a known output conditions while activating the supply rail.

#### Propagation delay vs supply voltage at $V_{icm}=V_{cc}/2$

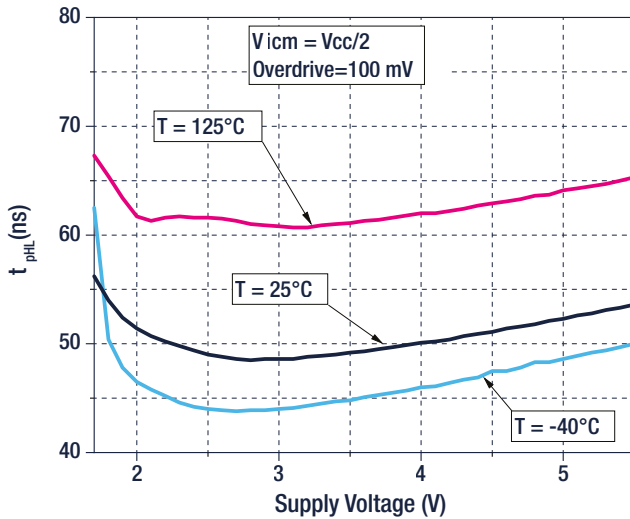

#### MAIN FEATURES

- AEC-Q100 qualified
- Wide supply voltage: 1.7 to 5.5 V
- Propagation delay: 60 ns
- Rail-to-rail input
- Open-drain output
- Embedded PoR for TS3121P (P version)
- Low offset voltage: 2 mV (A version)
- High ESD tolerance: 4 kV HBM
- Extended temperature range: -40 to +125°C
- Packages: SC70-5, SOT23-5



### High speed comparators

Part number	Typ. response time (ns)	Min. $V_{cc}$ (V)	Max. $V_{cc}$ (V)	Typ. $I_{cc}$ per channel	Rail-to-rail In	Output type	Input type	Package		
								Single	Dual	Quad
TS3011	8	2.2	5	470	Yes	Push-pull	CMOS	SOT23-5, DFN8 (2x2 WF), SC70-5	NA	
TS3021/2	42	1.8	5	73	Yes	Push-pull	BIP	SOT23-5, SC70-5	S08, MiniS08	NA
TS3121P (*)	60	1.7	5.5	90	Yes	Open drain	CMOS	SOT23-5, SC70-5	NA	
TS3121/A	60	1.7	5.5	70	Yes	Open drain	CMOS	SOT23-5, SC70-5	NA	

Note: \* Embedded Power-on reset feature

## LOW POWER AND HIGH TEMPERATURE COMPARATORS

### TS882: nano power (220 nA) rail-to-rail 1.1 V dual comparator

The **TS882** is a dual comparator characterized by an ultra-low supply current, typically 220 nA per channel when the output is high, at a supply voltage of 1.2 V and no load. It features rail-to-rail input and output capabilities, making it suitable for a broad range of portable applications. This device is designed to minimize battery leakage current, thereby extending battery life. It operates across a supply voltage range from 1.1 V to 5.5 V and supports a wide temperature range from -40°C to +125°C, all while maintaining exceptionally low current consumption.

#### Current consumption per operator vs. supply voltage - output high

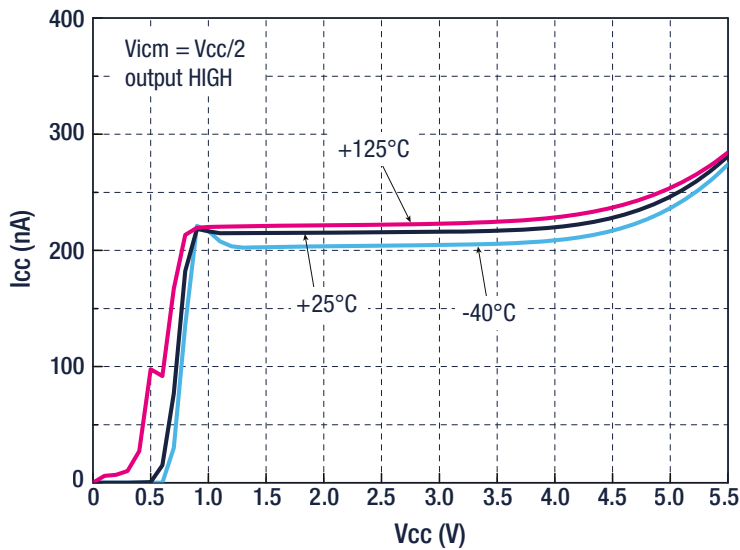

#### MAIN FEATURES

- AEC-Q100 qualified
- Supply voltage: 1.1 to 5.5 V
- Ultra-low current consumption: 220 nA
- Propagation delay: 2 μs
- Rail-to-rail input
- Push-pull outputs
- ESD tolerance: 8 kV HBM / 300 V MM
- Wide temperature range: -40 to +125°C
- Package: MiniSO8



#### Current consumption per operator vs. temperature

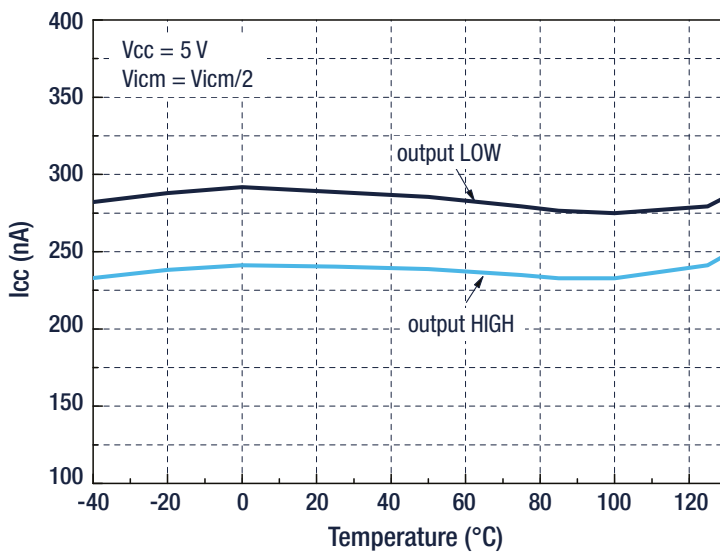

## Low power comparators

Part number	Typ. $I_{cc}$ per channel ( $\mu$ A)	Min. $V_{cc}$ (V)	Max. $V_{cc}$ (V)	Typ. response time (ns) 100 mV	Rail-to-rail In	Output type	Input type	Package		
								Single	Dual	Quad
TS882	0.21	1.1	6	2600	Yes	Push-pull	CMOS	NA	MiniSO8	NA
TSX3702/4	5	2.7	16	340	GND	Push-pull	CMOS	NA	S08	TSSOP14
TSX393/339	5	2.7	16	550	GND	Open drain	CMOS	NA	S08	TSSOP14
TS393	9	2.7	16	1500	GND	Open drain	CMOS	NA	S08	NA
TS331/2/4	20	1.6	5	270	Yes	Open drain	BIP	SOT23-5	S08	S014, TSSOP14
TS391	200	2	36	300	GND	Open collector	BIP	SOT23-5, DFN8 (2x2 WF)	NA	NA
LM2901/3	200	2	32	1300	GND	Open collector	BIP	NA	S08, TSSOP8, MiniSO8, DFN8 (2x2 WF)	QFN16 (3x3 WF), S014, TSSOP14
LM2903W	200	2	36	1300	GND	Open collector	BIP	NA	S08, TSSOP8	NA

## High temperature comparators

Part number	Max. operating temperature ( $^{\circ}$ C)	Typ. $I_{cc}$ per channel	Min. $V_{cc}$ (V)	Max. $V_{cc}$ (V)	Typ. response time (ns) 100 mV	Rail-to-rail In	Output type	Package		
								Single	Dual	Quad
TS3021H	150	73	1.8	5	42	Yes	Push-pull	SOT23-5	NA	
LM2901H/3H	150	200	2	36	300	GND	Open collector	NA	S08, TSSOP8	S014
LM2903WH	150	200	2	36	500	GND	Open collector	NA	S08, TSSOP8	NA

# Current sense amplifiers

## HIGH-SIDE AND HIGH TEMPERATURE CURRENT SENSE AMPLIFIERS

**TSC240: high-side, 100 V common mode, bidirectional, zero-drift current sense amplifier with enhanced PWM rejection**

The **TSC240** is a highly accurate current sense amplifier with an input offset voltage of  $\pm 20 \mu\text{V}$  and improved PWM noise rejection. It is capable of measuring current through a shunt resistor across a wide common-mode voltage range, spanning from  $-4 \text{ V}$  to  $+100 \text{ V}$ , independently of the supply voltage. The device comes with a fixed gain of  $20 \text{ V/V}$ . Its high precision allows it to detect very small voltage drops, thereby reducing measurement errors. The TSC240 is suitable for a variety of applications, including precise current measurement, overcurrent protection, current monitoring, and control feedback loops. It operates reliably over a wide supply voltage range from  $2.7 \text{ V}$  to  $5.5 \text{ V}$ .



### Input offset voltage vs. temperature

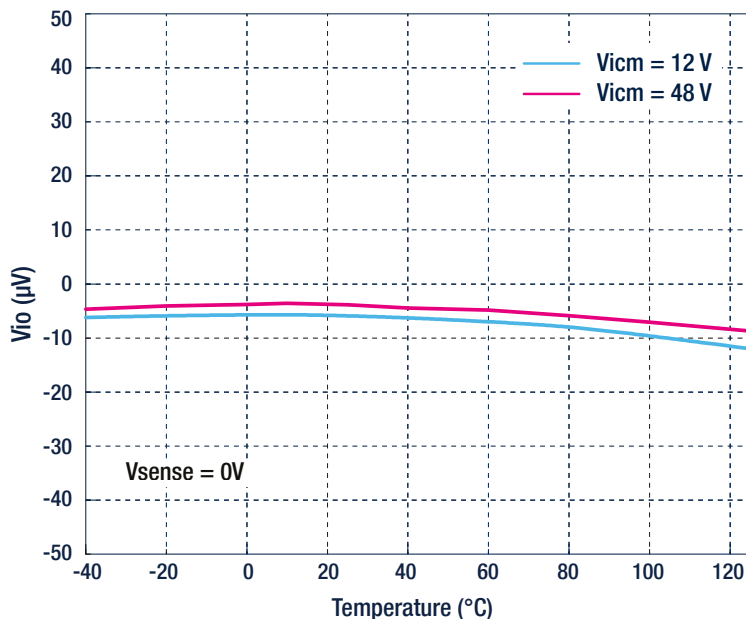

### MAIN FEATURES

- AEC-Q100 qualified
- Wide common mode voltage:  $-4$  to  $100 \text{ V}$
- High common mode rejection CMR:  $100 \text{ dB min.}$
- Offset voltage:  $\pm 20 \mu\text{V max.}$
- Offset drift:  $150 \text{ nV/}^\circ\text{C max.}$
- Enhanced PWM rejection
- $2.7$  to  $5.5 \text{ V}$  supply voltage
- Internal fixed gain:  $20 \text{ V/V}$
- Gain error:  $0.2\% \text{ max.}$
- Gain drift:  $2.5 \text{ ppm/}^\circ\text{C max.}$
- Packages: S08, TSSOP8

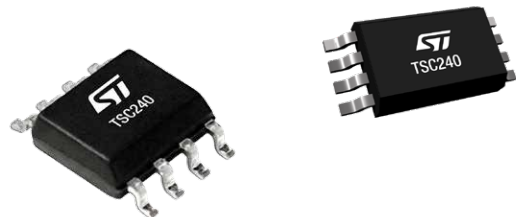

## High-side current sense amplifiers

Part number	Type	$V_{CM}$ (V)	$I_{CC}$ ( $\mu$ A)	$V_{supply}$ (V)	$V_{offset}^{max.}$ ( $\mu$ V)	Gain (V/V)	Package
TSC240	Bidirectional	-4 to 100	1900	2.7 to 5.5	20	20	S08, TSSOP8
TSC2020/2021/2022	Bidirectional	-4 to 100	1700	2.7 to 5.5	150	20 / 50 / 100	MiniS08, S08, TSSOP8
TSC2010/2011/2012	Bidirectional	-20 to 70	1500	2.7 to 5.5	200	20 / 60 / 100	MiniS08, S08
TSC210/211/212 TSC213/214/215	Bidirectional	-0.3 to 26	100	2.7 to 26	35 / 35 / 35 100 / 60 / 60	200 / 500 / 1000 50 / 100 / 75	QFN10, SC70-6
TSC200/201/202 (*)	Unidirectional	-16 to 80	840	2.7 to 18	2500	20 / 50 / 100	MiniS08, S08
TSC103	Unidirectional	2.9 to 70	200	2.7 to 5.5	500	20 / 25 / 50 / 100	S08, TSSOP8
TSC1031	Unidirectional	2.9 to 70	200	2.7 to 5.5	500	50 / 100	S08, TSSOP8
TSC102 (**)	Unidirectional	2.8 to 30	420	3.3 to 5.5	1500	20	S08, TSSOP8
TSC1021	Unidirectional	2.8 to 30	300	3.3 to 5.5	1500	20 / 50	TSSOP8
TSC101	Unidirectional	2.8 to 30	300	4 to 24	200	20 / 50 / 100	SOT23-5

Note \* TSC family with integrated comparator and Vref, \*\* TSC with integrated signal conditioning amplifier

## High temperature current sense amplifiers

Part number	Type	$V_{CM}$ (V)	$I_{CC}$ ( $\mu$ A)	$V_{supply}$ (V)	$V_{offset}^{max.}$ ( $\mu$ V)	Operating temp ( $^{\circ}$ C)	Gain (V/V)	Package
TSC2010H/2011H/2012H	Bidirectional	-20 to 70	1500	2.7 to 5.5	200	-40 to 150	20 / 60 / 100	S08, TSSOP8

## Evaluation boards

Part number	Description	Documentation Ref.
STEVAL-ISQ007V1	High-side current-sense amplifier demonstration board based on TSC101	AN2727
STEVAL-ISQ010V1	High-side current-sense amplifier demonstration board based on TSC102	DB0982
STEVAL-ISQ014V1	Low-side current sensing based on TSZ121	UM1737
STEVAL-AETKT1V2	High-side current-sense amplifier demonstration board based on TSC2010/2011/2012	DB4135
STEVAL-AETKT2V1	Evaluation kit for high precision bidirectional current sense amplifiers	DB4471
STEVAL-AETKT3V1	Evaluation kit for high voltage current sense amplifier with comparator based on the TSC200/201/202	DB5190
STEVAL-AETKT4V1	Evaluation kit for high voltage, precision current sense amplifier based on the TSC2020/21/22	DB5336

## LOW-SIDE CURRENT SENSE AMPLIFIERS

### TSC1801: low-side, very high accuracy (0.5%), high bandwidth (2.1 MHz) bidirectional current sense amplifier

The **TSC1801** is a low-side current sensing amplifier designed to measure voltage drops across shunt resistors at low common-mode voltages. It features a fixed gain of 20 V/V, selectable by part number. Low-side current measurement offers several advantages, including a simple circuit configuration, high measurement accuracy due to the ground-referenced design which improves noise immunity, and a cost-effective overall solution by utilizing inexpensive resistors and operational amplifiers.



#### Internal schematic

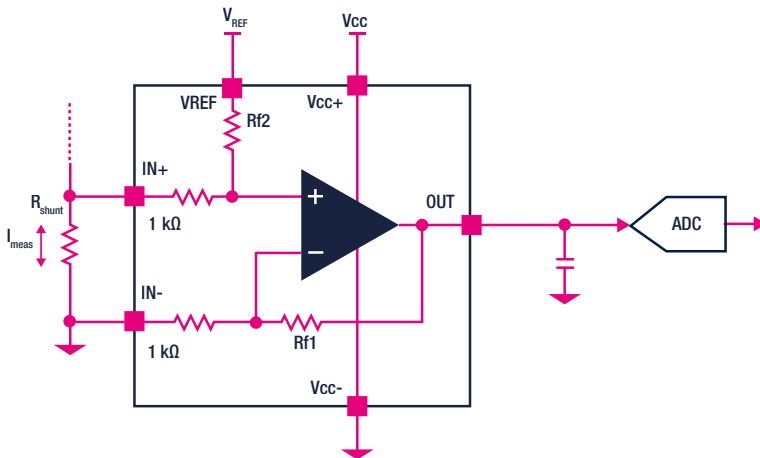

#### MAIN FEATURES

- AEC-Q100 qualified
- Supply voltage range: 2.0 V to 5.5 V
- Fixed gain: 20 V/V
- Total output error < 0.5%
- Offset voltage:  $\pm 200 \mu\text{V}$  max.
- Gain error: 0.1% max.
- Bandwidth: 2.1 MHz
- Extended temperature range:  $-40^\circ\text{C}$  to  $+125^\circ\text{C}$
- Safety capable: documentation available to support functional safety system design
- Package: SOT23-6

#### Typical application schematic

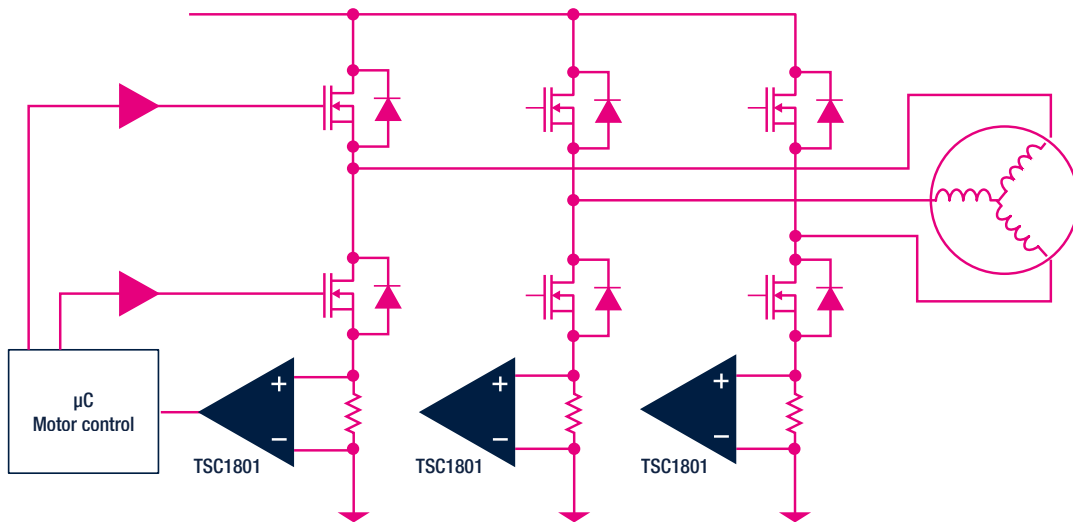

#### Low side current sense amplifiers

Part number	Type	$V_{CM}$ (V)	$I_{CC}$ ( $\mu\text{A}$ )	$V_{supply}$ (V)	$V_{offset\ max}$ ( $\mu\text{V}$ )	Gain (V/V)	Package
TSC1801	Bidirectional	-0.1 to 4	3300	2 to 5.5	200	20	SOT23-6

# Voltage references

## SHUNT VOLTAGE REFERENCES

### TL1431: adjustable precision voltage reference

The **TL1431** is a programmable shunt voltage reference with guaranteed stability over the entire operating temperature range. The output voltage may be set to any value between 2.5 and 36 V with two external resistors. The TL1431 operates throughout a wide current range from 1 to 100 mA with a typical dynamic impedance of 0.2  $\Omega$ .



### MAIN FEATURES

- AEC-Q100 qualified
- Adjustable output voltage: VREF to 36 V
- Sink current capability: 1 to 100 mA
- Typical output impedance: 0.22  $\Omega$
- 0.4 % and 0.25 % voltage precision
- Operating temperature range: -40 to +125°C
- Package: S08

Reference voltage vs. temperature

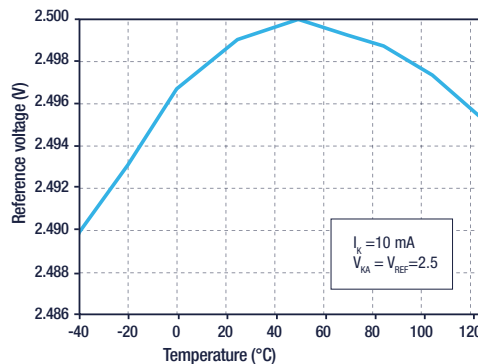

Pulse response for  $I_k = 1$  mA

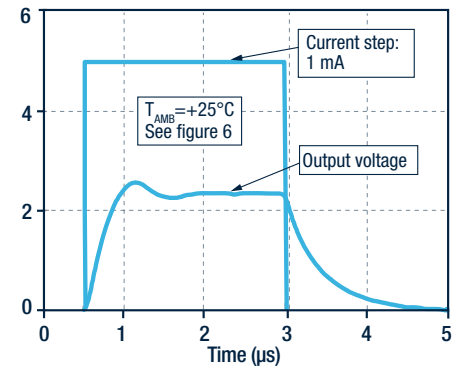

## Shunt voltage references

Part number	Adjustable	$V_{REF}$ (V)	Reference Input voltage (V)	Initial accuracy (%)	Temperature coefficient max (ppm /°C)	Sink current range	Operating temperature range (°C)	Package
TL431AIYDT	Yes	2.5 to 36	2.5	$\pm 1$	$\pm 30$	1 mA to 100 mA	-40 to 125	S08
TL431IYDT				$\pm 2$				
TL1431AIYDT				$\pm 0.25$				
TL1431IYDT				$\pm 0.4$				
TS431IYLT		1.24 to 6	1.24	$\pm 2$	$\pm 21$	60 $\mu$ A to 30 mA	-40 to 125	SOT23-5L
TS431AIYLT				$\pm 1$				
TS431BIYLT	$\pm 0.5$							

# Watchdog, reset and supervisor ICs

## STWD100: watchdog timer circuit for automotive applications

The **STWD100** watchdog timer circuits are self-contained devices which prevent system failures caused by certain types of hardware errors (including non-responding peripherals and bus contention) or software errors (such as a bad code jump or code stuck in loop). A watchdog input (WDI) signal periodically resets the internal watchdog timer within a specified timeout period. If the system fails, the watchdog timer is not reset, a system alert is generated and the watchdog output is asserted. The small SOT23-5 package ensures a small board impact area and has a low current consumption of only a few  $\mu\text{A}$ .



### MAIN FEATURES

- AEC-Q100 qualified
- Current consumption 13  $\mu\text{A}$  (typ.)
- Supply voltage: 2.7 to 5.5 V
- Available watchdog timeout periods are 3.4 ms, 6.3 ms, 102 ms, and 1.6 s
- Chip enable input
- Open-drain or push-pull WDO output
- Operating temperature range: - 40 to +125 °C
- ESD performance: 2 kV (HBM) and 1 kV (CDM)
- Package: SOT23-5

Part number	Watchdog	Supervisor	Manual reset input	V <sub>DD</sub> (V)	I <sub>CC</sub> ( $\mu\text{A}$ )	Watchdog Timeout Period	Output type	Reset Pulse width	Package
STWD100YNPWY3F	Yes	No	No	2.7 to 5.5	13	3.4 ms	Open-drain	NA	SOT23-5
STWD100YNWWY3F						6.3 ms			
STWD100YNXWY3F						102 ms			
STWD100YNYWY3F						1.6 s			

# Logic ICs

The automotive-grade logic ICs offer a range of products including counters / encoders / decoders, gates, flip-flop / registers and buffer drivers, that fulfill all test and quality requirements for AEC-Q100 qualification in both highly reliable standard SO and TSSOP packages.



## Logic ICs

Commercial Product	Function	Packages
74LCX125YMTR / 74LCX125YTTR	Quad Bus Buffer (3-State)	S014, TSSOP14
74VHC14YMTR / 74VHC14YTTR	Hex Schmitt Inverter	S014, TSSOP14
74LCX07YMTR / 74LCX07YTTR	Hex Buffer	S014, TSSOP14
74LCX00YMTR / 74LCX00YTTR	Quad 2-Input NAND Gate	S014, TSSOP14
HCF40106YM013TR	Hex Schmitt Trigger	S014
HCF4010YM013TR	Hex Buffer/Converters non Inverting	S016
HCF4013YM013TR	Dual D Flip-Flop	S014
HCF4021YM013TR	8-Stage Static Shift Register	S016
HCF4051YM013TR	Single 8-channel Analog Mux/Demux	S016
HCF4060YM013TR	14-stage counter/Driver AND Oscillator	S016
HCF4069YM013TR	Hex Inverter	S014
HCF4070YM013TR	Quad Exclusive OR Gate	S014
HCF4093YM013TR	Quad 2-Input NAND Schmitt Trigger	S014
HCF4094YM013TR	8-Stage Shift-AND-Store Bus Register	S016
M74HC4851YRM13TR / M74HC4851YTTR	Single 8-channel Analog Mux/Demux	S016, TSSOP16
M74HC4852YRM13TR	Dual 4-channel Analog Mux/Demux	S016
M74HC04YRM13TR / M74HC04YTTR	Hex Inverter	S014, TSSOP14
M74HC08YRM13TR / M74HC08YTTR	Quad 2-Input AND Gate	S014, TSSOP14
M74HC126YRM13TR / M74HC126YTTR	Quad Bus Buffer (3-State)	S014, TSSOP14
M74HC132YRM13TR / M74HC132YTTR	Quad 2-Input Schmitt NAND Gate	S014, TSSOP14
M74HC14YRM13TR / M74HC14YTTR	Hex Schmitt Inverter	S014, TSSOP14
M74HC151YRM13TR / M74HC151YTTR	8-channel Multiplexer	S016, TSSOP16
M74HC259YRM13TR / M74HC259YTTR	8-bit Addressable Latch	S016, TSSOP16
M74HC280YRM13TR	9-bit Parity Generator	S014
M74HC4060YRM13TR / M74HC4060YTTR	14-stage Binary Counter/Oscillator	S016, TSSOP16
M74HC4094YRM13TR / M74HC4094YTTR	8-bit SIPO Shift Register Latch (3-State)	S016, TSSOP16
M74HC595YRM13TR / M74HC595YTTR	8-bit Shift Register Output Latch (3-State)	S016, TSSOP16
M74HC365YRM13TR / M74HC365YTTR	Hex Bus Buffer (3-State)	S016, TSSOP16

# eDesignSuite

## THE SMART DESIGN TOOL

ST's eDesignSuite is a smart design and simulation tool that greatly simplifies the task of engineers working on various application types. This platform helps to select the best product for your application and speeds -up the design-in! To use the eDesignSuite, you must first register on MyST at

<https://eds.st.com/console/#/home>

Available modules

- Power management
- Thermo-electrical simulator
- Signal conditioning
- NFC/RFID calculators

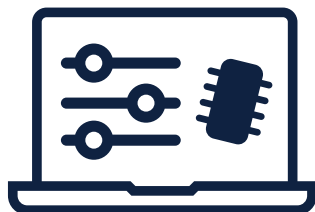
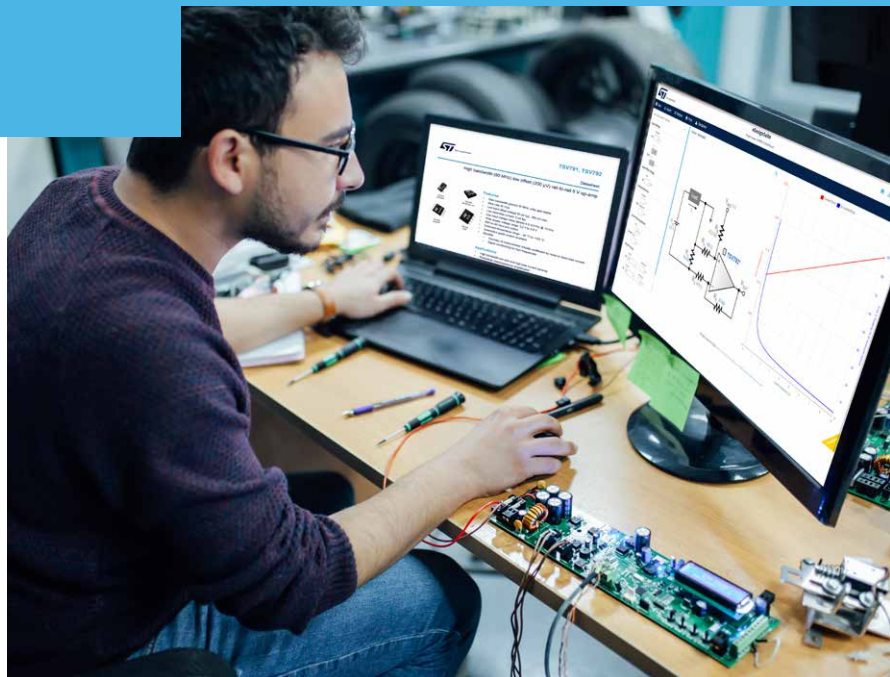

STEP 1

- Select the module

STEP 2

- Select the type of product family

STEP 3

- Adjust your choice with different parameters (stability, efficiency, center frequency, bandwidth...)

...you can then

- Get the suggested schematics
- Get the Bill Of Material (BOM)
- Get the different charts depending on the selected product (waveforms, efficiency, gain, phase...) in order to analyze your filter easily

- Access the Datasheet
- Access the Product folder
- Save and export a PSPICE model
- Export for eDSim





# At STMicroelectronics we create technology that starts with You



Order code: BR2605AUTOICS

For more information on ST products and solutions, visit [www.st.com](http://www.st.com)

© STMicroelectronics - May 2026 - Printed in the United Kingdom - All rights reserved  
ST and the ST logo are registered and/or unregistered trademarks of STMicroelectronics International NV or its affiliates in the EU and/or elsewhere. In particular, ST and the ST logo are Registered in the US Patent and Trademark Office. For additional information about ST trademarks, please refer to [www.st.com/trademarks](http://www.st.com/trademarks).  
All other product or service names are the property of their respective owners.

