

Configurable octal half-bridge DC motor driver board based on the L99MH98

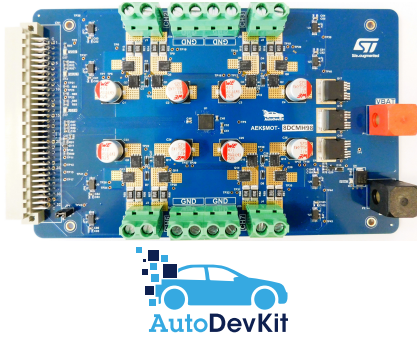

Features

- **L99MH98** octal half-bridge, or quad H-bridge, predriver for DC motors in automotive applications
- Independent channel driver up to 8 high-side or 8 low-side MOSFETs
- 15 A motor drive per single channel in half-bridge mode
- 30 A at $V_{bat} = 12\text{ V}$ motor drive per double channel in full bridge mode
- Adaptive MOSFET gate control
 - Three-step gate control of external high-side or low-side MOSFETs
 - Optimized electromagnetic interference (EMI)
 - Programmable gate current up to 120 mA
 - Reduced switching losses in PWM level mode
- Protection and diagnostic features
- Watchdog timeout by MCU control board
- Drain-source monitoring for short-circuit detection
- Undervoltage lockout
- Reverse battery protection dedicated circuit
- Overtemperature warning and shutdown
- Detailed off-state diagnostic via SPI
- Programmable diagnostic load on all channels
- Load channel direct current measurement via shunt resistors from 1.5 to 50 A
- Standardized 96-pin plug-and-play automotive unified connector to plug MCU boards (for example, AEK-MCU-C4M3 belonging to the AEK-MCU-C4MLIT3 evaluation kit)
- Compact size: 112 x 180 mm
- Included in the [AutoDevKit](#) ecosystem

Product summary	
Configurable octal half-bridge DC motor driver board based on the L99MH98	AEK-MOT-8DCMH98
Octal half-bridge pre-driver	L99MH98-TR
Cost-optimized and compact size MCU discovery kit for SPC58EC80E5 Chorus 4M automotive microcontroller with CAN-FD and unified automotive connector	AEK-MCU-C4MLIT3
AutoDevKit Studio for 32-bit power architecture MCUs	STSW-AUTODEVKIT
Applications	Automotive motor control Body and convenience Chassis and safety

Description

The key objective of the **AEK-MOT-8DCMH98** is to drive brushed DC motors for a wide range of body control and convenience applications, such as seat control, steering column adjustment, gas pedal adjustment, sunroof, sliding doors, window lift, and washer pump.

The board also supports safety applications, including seatbelt pretensioners and central door lock (crash unlock), as well as chassis and powertrain applications, such as engine vibration compensation systems.

This six-layer board, with 2 oz copper thickness on the top and bottom layers, features optimized current handling, thanks to some duplicated layers that shield signal traces.

The **AEK-MOT-8DCMH98** is based on the **L99MH98** octal half-bridge predriver for brushed DC motor control applications.

It is designed to drive eight configurable channels in half-bridge or four channels in full-bridge mode. It manages up to 30 A per channel in H-bridge configuration and 15 A per channel in half-bridge configuration.

In this application, the **AEK-MOT-8DCMH98** can drive four motors simultaneously. As the **L99MH98** integrates the control of eight external half-bridges in an independent and configurable way, it can also be used in several other application scenarios.

For example, the board can drive two resistive loads, such as a heater or fan, using a high-side and a low-side configuration, and control two motors with two H-bridges. Alternatively, the board can control and drive seven motors sequentially using eight half-bridges.

The [AEK-MOT-8DCMH98](#) supports two types of current measurement systems: the classical method, which is based on current measurement through a sensing resistor connected in series between the power source and the load, and an innovative indirect current measurement based on MOSFETs external to [L99MH98](#).

The indirect method allows cost savings and reduces system complexity by eliminating the need for shunt resistors and the related conditioning circuitry necessary for correct acquisition by the microcontroller unit (MCU).

The control board manages the [L99MH98](#) through a 24-bit serial peripheral interface (SPI).

Through SPI status registers, it provides high-level diagnostic information, such as supply voltage monitoring, charge pump voltage monitoring, temperature warning, and overtemperature shutdown.

Each gate driver monitors its external MOSFET drain-source voltage for fault conditions.

The innovative and efficient three-stage gate current drives the external MOSFETs and optimizes electromagnetic interference (EMI).

The [L99MH98](#) protection features, including drain-source monitoring for short-circuit detection, overtemperature warning and shutdown, timeout watchdog for microcontroller control, and detailed off-state diagnostics via SPI, ensure ASIL-B compliance according to the ISO 26262 standard.

By leveraging the [L99MH98](#) off-state diagnostic feature, the [AEK-MOT-8DCMH98](#) offers three diagnostic functions on the load output to detect potential short-to-ground, short-to-battery, and open-load conditions when the [L99MH98](#) is in the off state.

The off-state diagnostic can be performed for loads that are infrequently activated. The MOSFET short-circuit conditions are detected without the stress inherent to on-state diagnostic mode.

For example, the microcontroller can perform an off-state diagnostic immediately before the activation request of the load. Upon detection of a fault condition, the application software can report the failure and inhibit load activation, preventing any stress to the MOSFETs.

In case of failures, the [L99MH98](#) switches the gate drivers off to protect the device or application. At the same time, the DIAG pin immediately changes the logic level output and warns the external microcontroller unit (MCU), which reads the necessary registers to ensure prompt intervention in open-load, short-to-ground, short-to-battery, thermal warning, overtemperature shutdown, undervoltage, and overcurrent protection conditions.

To provide robust protection and prevent damage due to power supply polarity inversion, reverse polarity protection is implemented. For systems requiring a higher safety level, a watchdog with a configurable time window can be enabled.

The [AEK-MOT-8DCMH98](#) can be connected to a microcontroller board, such as the [AEK-MCU-C4M3](#) included in the [AEK-MCU-C4MLIT3](#) evaluation kit, using its 96-pin automotive unified connector for SPI communication and current sensing.

Finally, the board is a functional block of the AutoDevKit ecosystem. Release 2.7.0 (available at [STSW-AUTODEVKIT](#)) includes a dedicated demo to simplify board configuration and usage.

This demo shows how to control two motors using the [L99MH98](#) predriver in full-bridge configuration on channels 1 and 2 for bidirectional motor control or in half-bridge configuration on channel 3 for unidirectional motor control.

The demo changes the motor speed by adjusting the PWM duty cycle every 1.5 seconds.

Every 9 seconds, the direction of the full-bridge motor on channels 1 and 2 is reversed.

The demo also measures and logs voltages and load currents for all active channels.

1 System requirements, HW and SW resources

Figure 1. AEK-MOT-8DCMH98 connected to AEK-MCU-C4M3 MCU board: 4-bidirectional DC motors application diagram

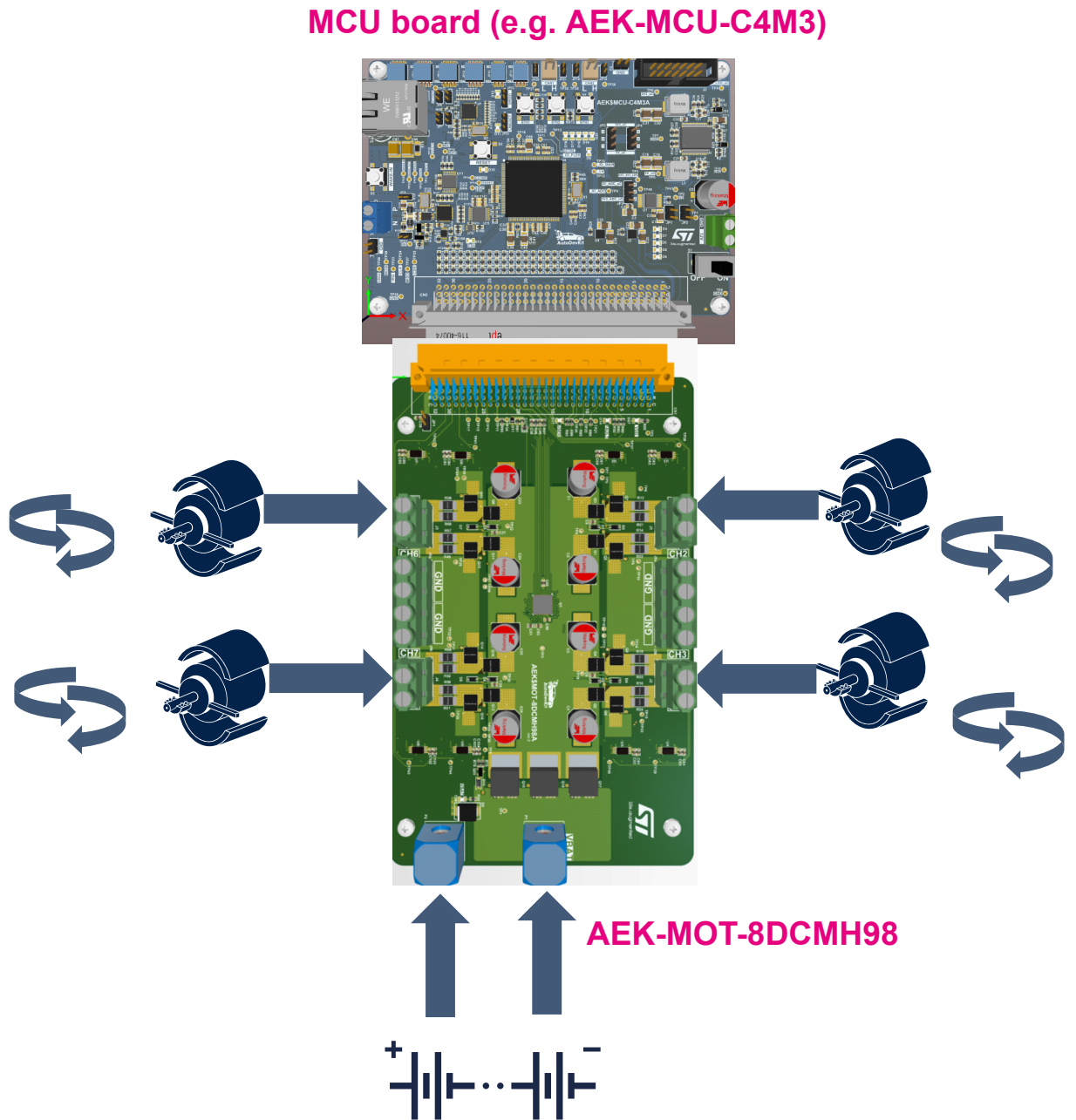

Figure 2. AEK-MOT-8DCMH98 connected to AEK-MCU-C4M3 MCU board: 8-unidirectional DC motors application diagram

MCU board (e.g. AEK-MCU-C4M3)

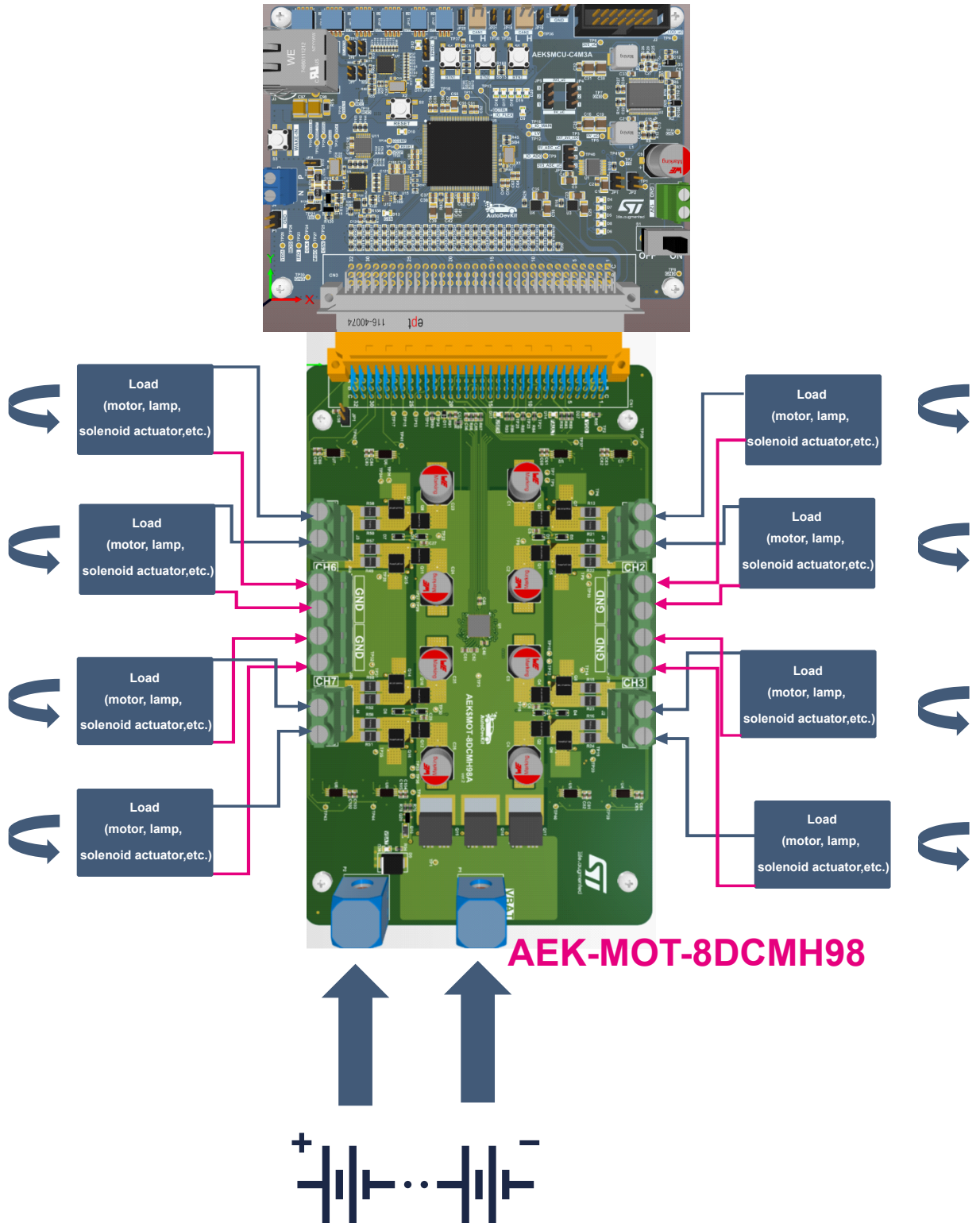
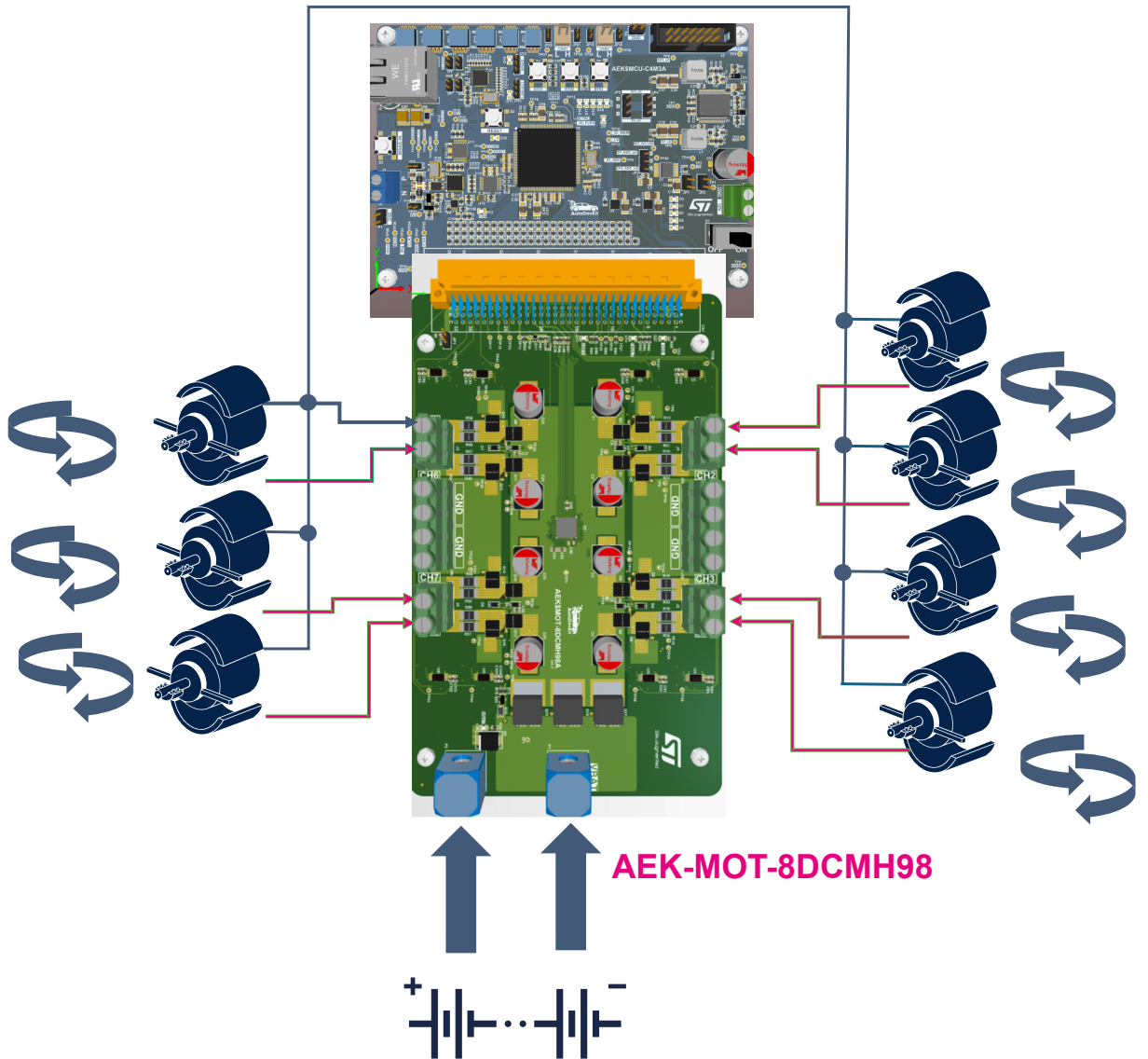

Figure 3. AEK-MOT-8DCMH98 connected to AEK-MCU-C4M3 MCU board: 7-bidirectional sequential DC motors application diagram

MCU board (e.g. AEK-MCU-C4M3)



2 Schematic diagrams

Figure 4. AEK-MOT-8DCMH98 circuit schematic (1 of 4)

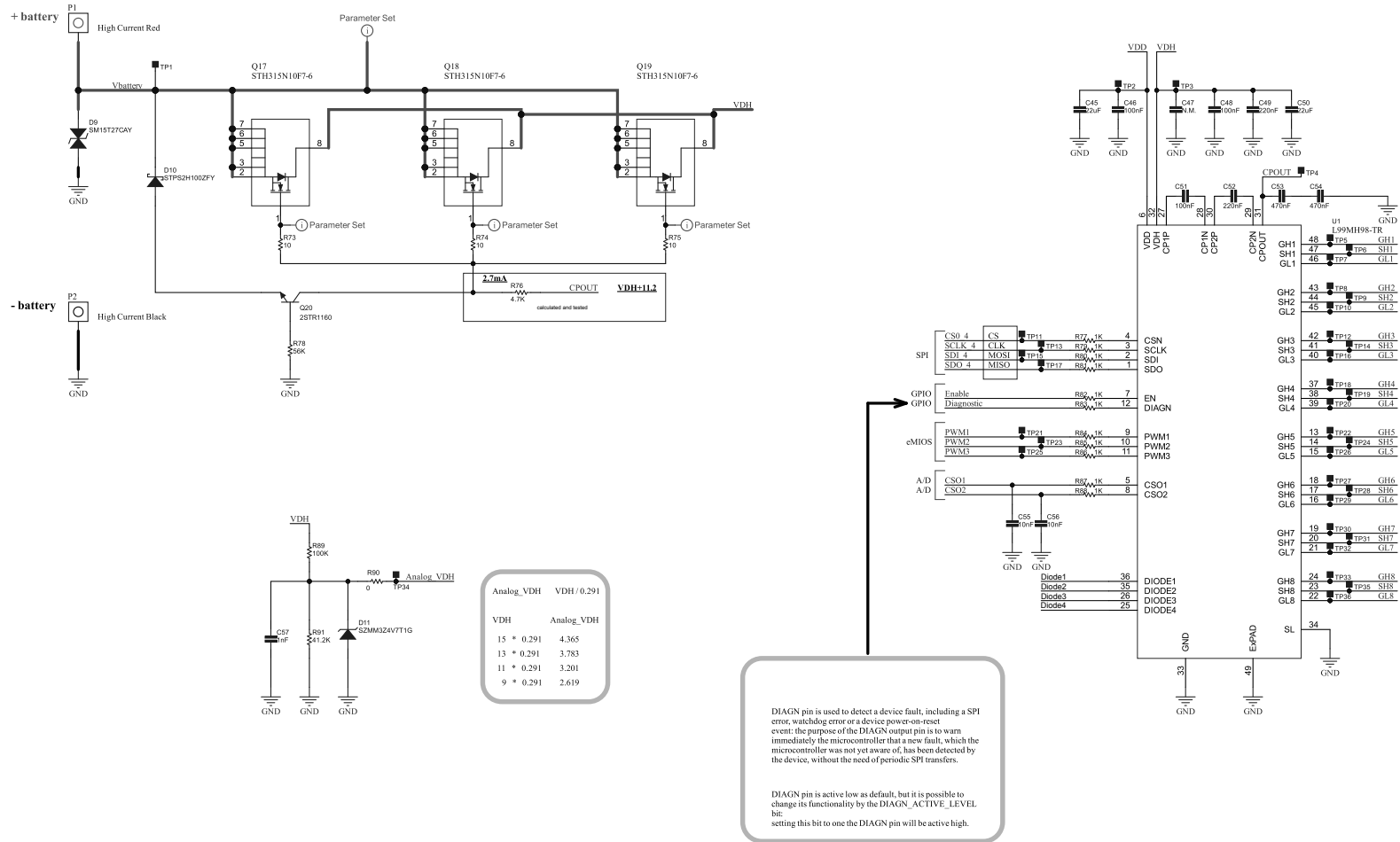
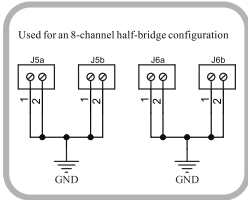
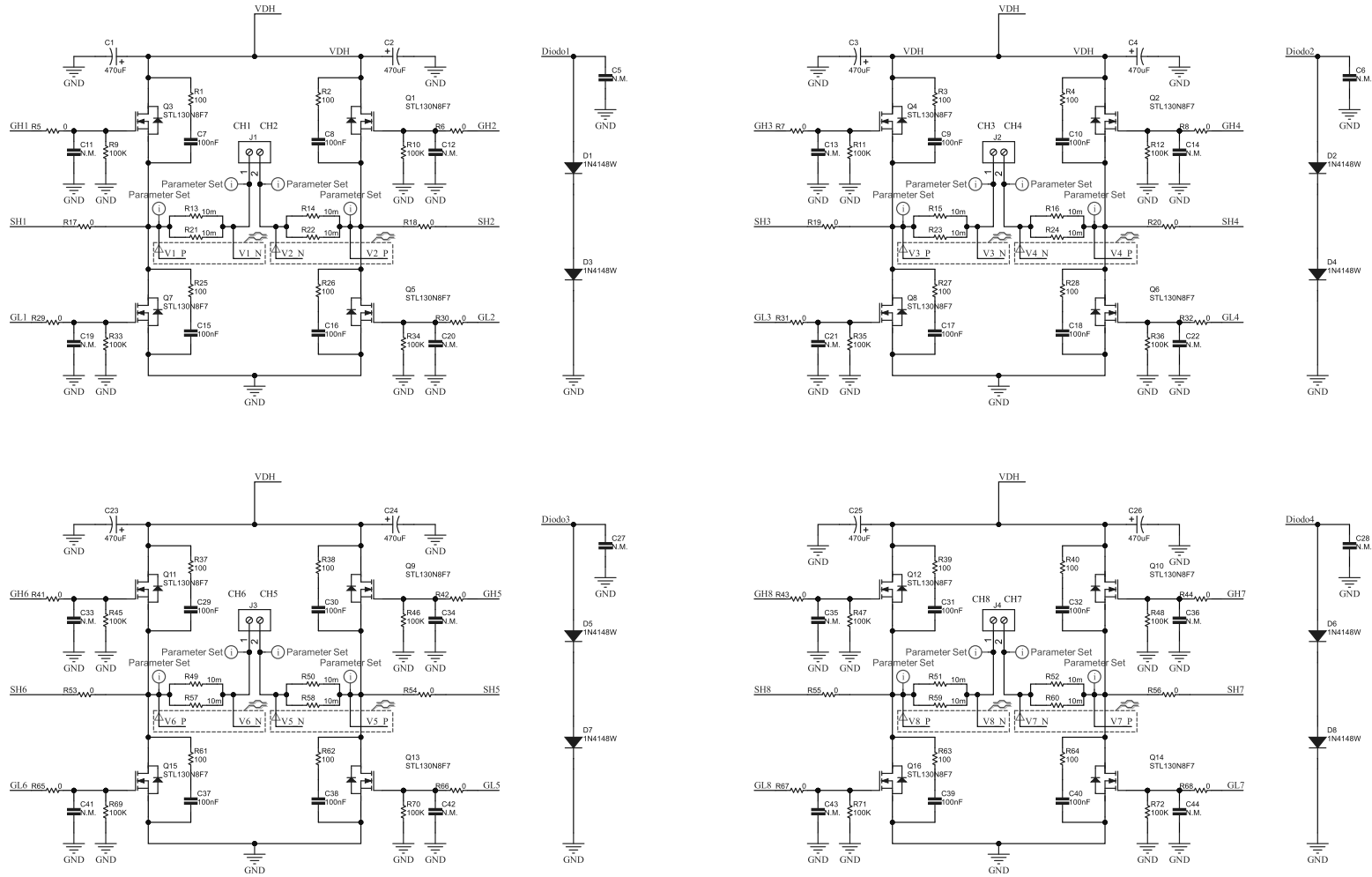

Figure 5. AEK-MOT-8DCMH98 circuit schematic (2 of 4)



Order code	V _{DS}	R _{DS(on)} max.	I _D	P _{TOT}
STL130N8F7	80 V	3.6 mΩ	120 A	135 W



Figure 6. AEK-MOT-8DCMH98 circuit schematic (3 of 4)

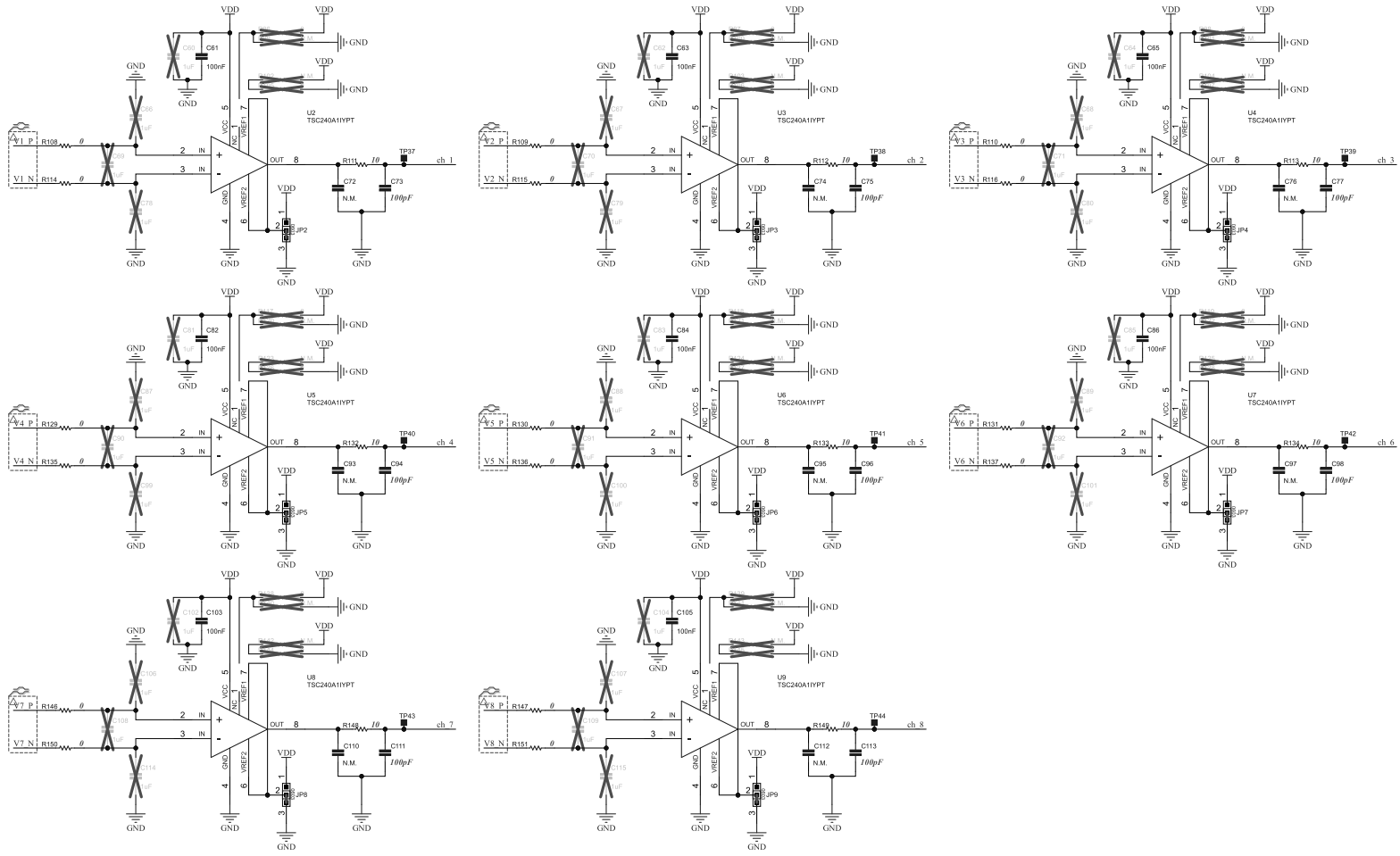
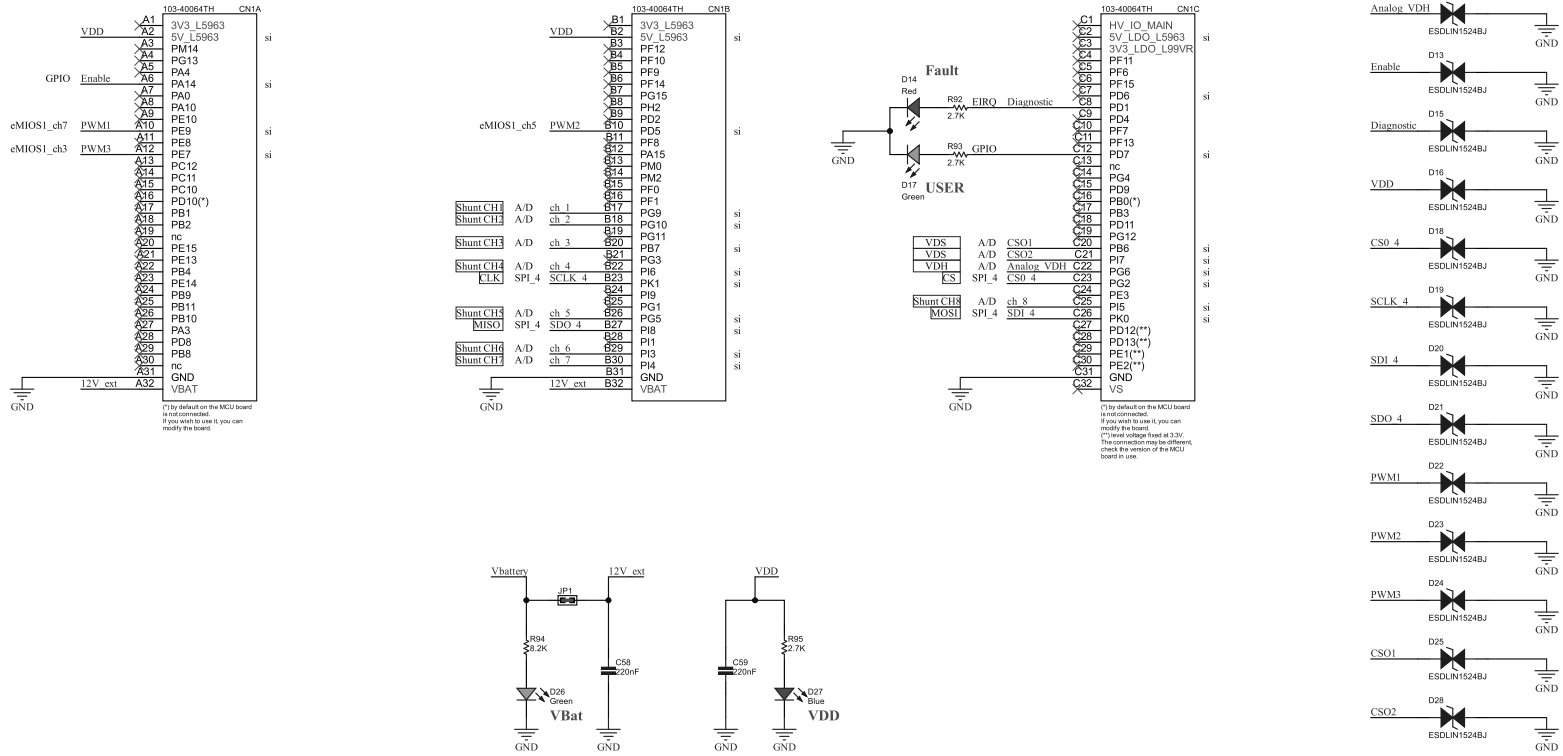

Figure 7. AEK-MOT-8DCMH98 circuit schematic (4 of 4)



3 Board versions

Table 1. AEK-MOT-8DCMH98 versions

Finished good	Schematic diagrams	Bill of materials
AEK\$MOT-8DCMH98A ⁽¹⁾	AEK\$MOT-8DCMH98A schematic diagrams	AEK\$MOT-8DCMH98A bill of materials

1. This code identifies the AEK-MOT-8DCMH98 evaluation board first version.

Revision history

Table 2. Document revision history

Date	Revision	Changes
12-Jun-2026	1	Initial release.

IMPORTANT NOTICE – READ CAREFULLY

STMicroelectronics NV and its subsidiaries (“ST”) reserve the right to make changes, corrections, enhancements, modifications, and improvements to ST products and/or to this document at any time without notice.

In the event of any conflict between the provisions of this document and the provisions of any contractual arrangement in force between the purchasers and ST, the provisions of such contractual arrangement shall prevail.

The purchasers should obtain the latest relevant information on ST products before placing orders. ST products are sold pursuant to ST’s terms and conditions of sale in place at the time of order acknowledgment.

The purchasers are solely responsible for the choice, selection, and use of ST products and ST assumes no liability for application assistance or the design of the purchasers’ products.

No license, express or implied, to any intellectual property right is granted by ST herein.

Resale of ST products with provisions different from the information set forth herein shall void any warranty granted by ST for such product.

If the purchasers identify an ST product that meets their functional and performance requirements but that is not designated for the purchasers’ market segment, the purchasers shall contact ST for more information.

ST and the ST logo are trademarks of ST. For additional information about ST trademarks, refer to www.st.com/trademarks. All other product or service names are the property of their respective owners.

Information in this document supersedes and replaces information previously supplied in any prior versions of this document.

© 2026 STMicroelectronics – All rights reserved