

## Adaptive Front Light testing and prototyping kit arranged on plexiglass panel

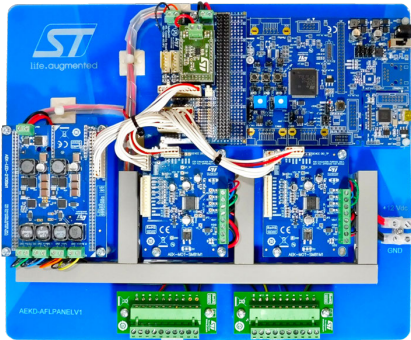

### Features

- Panel arrangement of boards forming an adaptive front light (AFL) system.
- Panel size: 330 x 270 x 40 mm (approx.).
- Designed for application development and testing, allowing rapid interchanging of function and control boards.
- Several evaluation boards mounted on panel provide independent control of:
  - two stepper motors for light projection angle adjustment (X and Y directions)
  - LED string currents for high beam, low beam, daytime running lights (DRL) and direction lights
  - a cooling fan
- All the above loads are included in the (AEKD-AFLLIGHT1) headlight assembly, available separately.
- Kit supplied complete with cables and connectors.
- Includes control board with SPC5 Chorus MCU to monitor entire system.
- Dedicated STSW-AFL001 firmware running on MCU includes sample code modules covering typical AFL functionality.
- Special connector board to easily link demo boards with MCU board.
- WEEE and RoHS compliant.
- All ST components are qualified Automotive grade.
- Part of the AutoDevKit initiative.

### Product summary

Plexiglass panel with AutoDevKit boards for vehicle adaptive front light systems	<a href="#">AEKD-AFLPANEL1</a>
Adaptive front lighting motor, light and fan loads for AutoDevKit	<a href="#">AEKD-AFLLIGHT1</a>
AutoDevKit adaptive front lighting kit firmware	<a href="#">STSW-AFL001</a>
Applications	Adaptive front lighting systems for vehicles Car chassis lighting

### Description

The [AEKD-AFLPANEL1](#) is a panel assembly of the driving hardware for an adaptive front light testing system featuring ST AutoDevKit boards on a specially designed perspex board that facilitates development and prototyping activities.

The panel provides a tidy arrangement of two stepper motor control boards, a four-channel LED driver board, a control board with SPC5 Chorus microcontroller for automotive applications, a connector board with a FAN switch board and further connector board for wiring configuration.

Used in conjunction with the [AEKD-AFLLIGHT1](#) demo automotive headlight assembly with LED lights, stepper motors and fan, these two kits provide a complete adaptive front lighting tool for application and solution development purposes.

## 1 Adaptive front lighting simulation tool overview

The set of AutoDevKit boards in this kit, together with the relevant firmware and sample application code in the [STSW-AFL001](#) software package, form a system that is able to control and drive an automotive adaptive front loading system for development purposes.

To build a complete physical simulation tool, the system must be complemented with appropriate loads, feedback sensors and communication ports.

**Figure 1. AutoDevKit adaptive front lighting system block diagram**

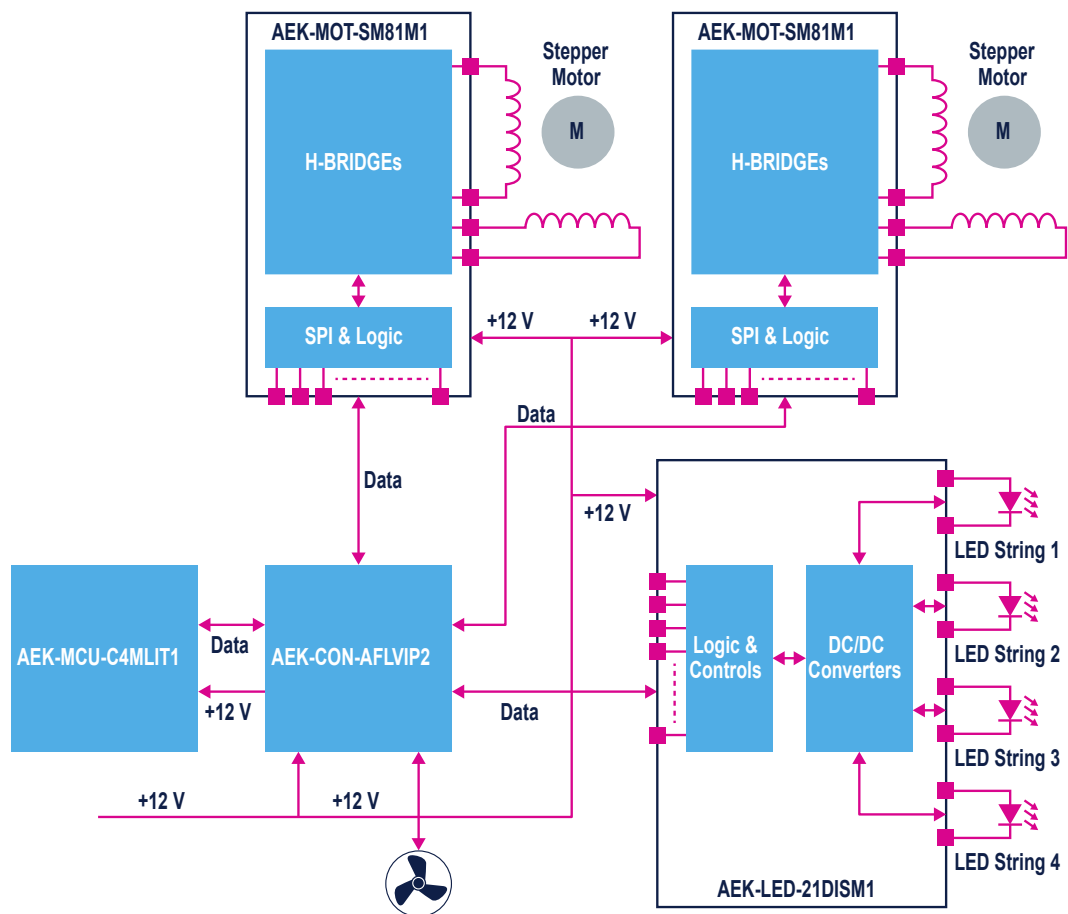

In the block diagram above, the loads are clearly indicated by the following elements:

- two stepper motors: one for up-down and one for lateral angular displacement of a light
- four LED lighting strings: high beam, low beam, DRL, direction light
- a cooling fan

ST conveniently supplies all of the above items in a single [AEKD-AFLLIGHT1](#) assembly inside a specially designed acrylic shroud with appropriate cabling and connectors.

**Figure 2. Adaptive front lighting headlight assembly**

1. Perspex headlight housing
2. turn indicator LED string
3. high beam LED light
4. low beam LED light
5. daytime running light LED string
6. adaptive X-axis position stepper motor
7. adaptive Y-axis position stepper motor
8. cooling fan
9. JPX2 connector
10. JPX3 connector

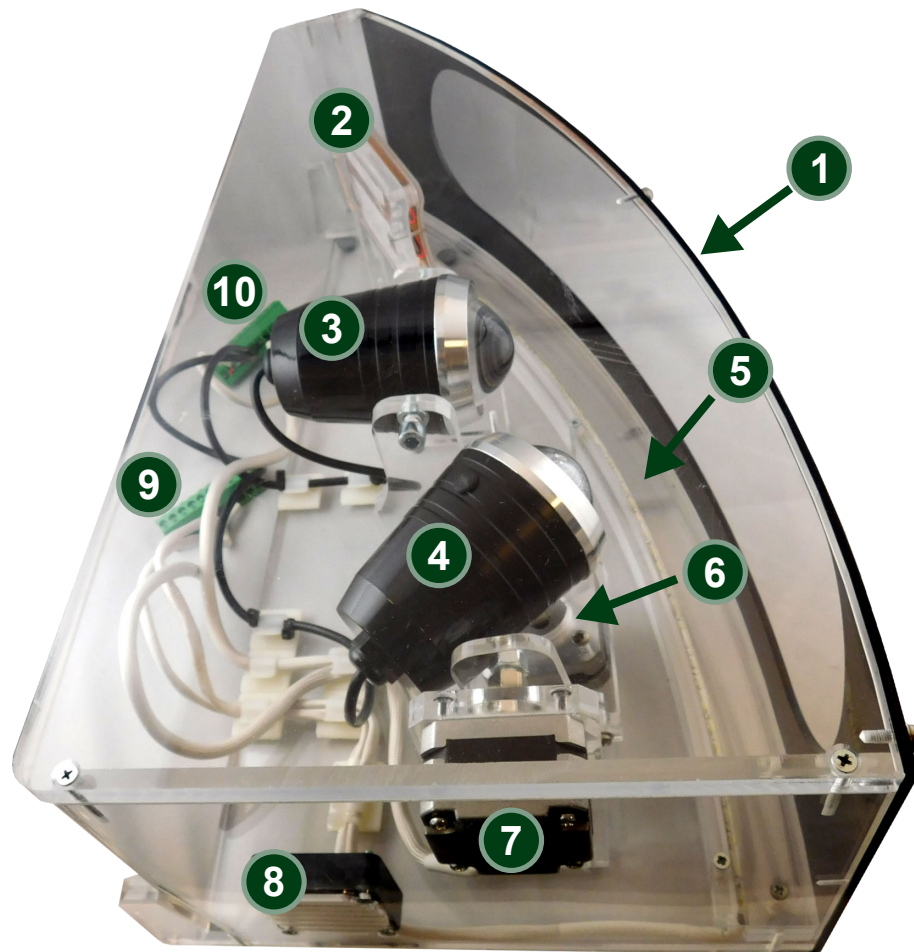

A real adaptive front lighting system would receive feedback data from sensors indicating the position or orientation of the motor vehicle steering wheel. This feedback information can be emulated with a potentiometer signal plugged to connector J5 (labeled ST.WHEEL) on the [AEK-CON-AFLVIP2](#) connector board, where different voltages will represent different steering wheel positions.

**Important:**

In order to enable manual steering wheel control, you must open the AutoDevKit library AFL demo project in [SPC5-STUDIO](#) and change the `#DEFINE AFLDemo_ManualMode` to `true` in the `AFL.h` file.

To ensure that manual operation does not remain the default mode when the system starts, short pins 5 and 6 of the J5 connector.

**Figure 3. AEK-CON-AFLVIP2 J4 (ST.WHEEL) and J5 (CAN) connectors**

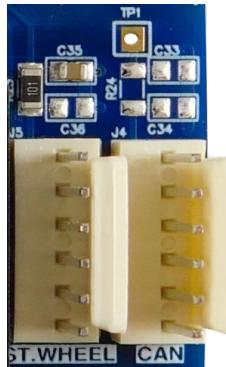

To connect the electronic control unit (ECU) with other ECUs such as the body control module (BCM) and/or cluster (to signal the actuation being performed on the dashboard), you can connect a CAN bus analyzer to connector J4 (labeled CAN) on the [AEK-CON-AFLVIP2](#) connector board. The analyzer shows the basic CAN messages that are transmitted when a single actuation in the headlight is performed. The CAN messages and periodicity can be customized using [SPC5-STUDIO](#) to edit the AFL demo available in the AutoDevKit library.

---

**RELATED LINKS**

[AutoDevKit: Adaptive Front Lighting demonstration kit video on YouTube](#)

---

## 2 Schematic diagrams

Figure 4. AEKD-AFLPANEL1 schematic diagram

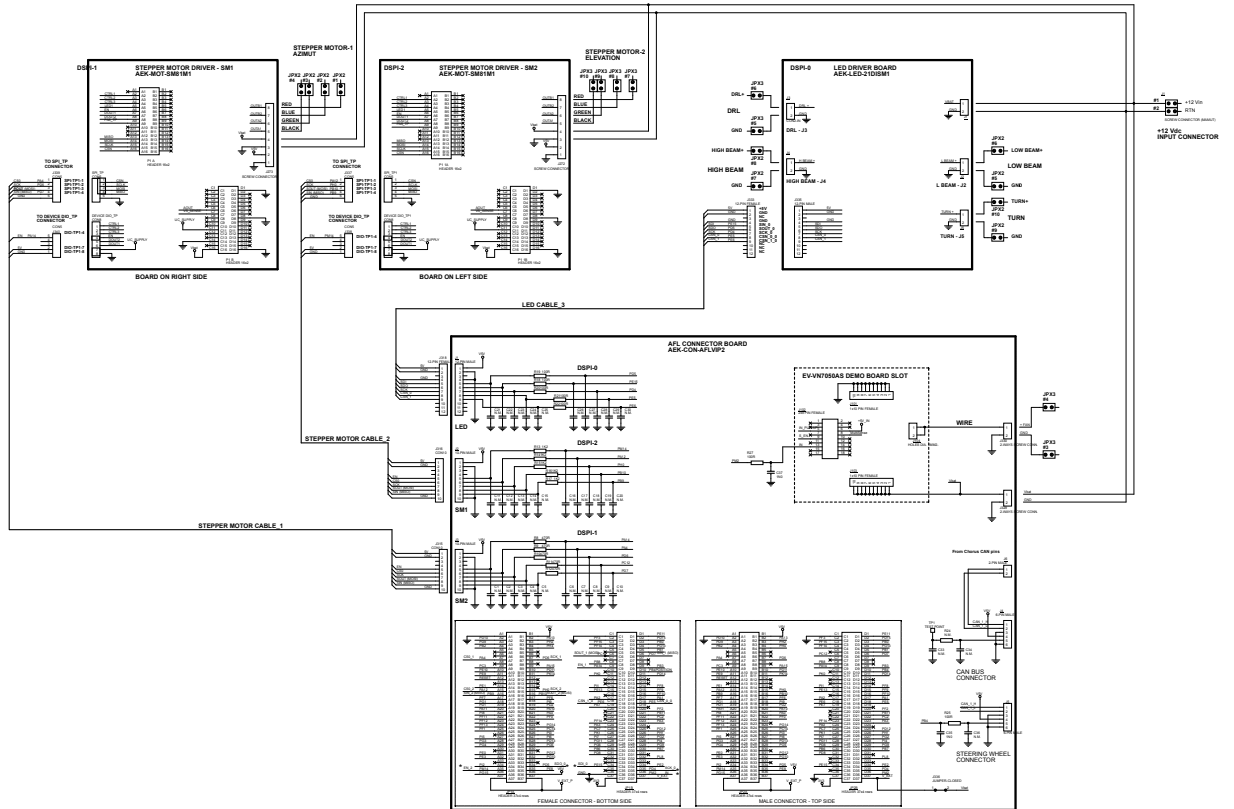

## Revision history

**Table 1. Document revision history**

Date	Version	Changes
26-Sep-2019	1	Initial release.

**IMPORTANT NOTICE – PLEASE READ CAREFULLY**

STMicroelectronics NV and its subsidiaries (“ST”) reserve the right to make changes, corrections, enhancements, modifications, and improvements to ST products and/or to this document at any time without notice. Purchasers should obtain the latest relevant information on ST products before placing orders. ST products are sold pursuant to ST’s terms and conditions of sale in place at the time of order acknowledgement.

Purchasers are solely responsible for the choice, selection, and use of ST products and ST assumes no liability for application assistance or the design of Purchasers’ products.

No license, express or implied, to any intellectual property right is granted by ST herein.

Resale of ST products with provisions different from the information set forth herein shall void any warranty granted by ST for such product.

ST and the ST logo are trademarks of ST. For additional information about ST trademarks, please refer to [www.st.com/trademarks](http://www.st.com/trademarks). All other product or service names are the property of their respective owners.

Information in this document supersedes and replaces information previously supplied in any prior versions of this document.

© 2019 STMicroelectronics – All rights reserved