

Features

- Mounted Engineering Model RHF350K1: Rad-hard, 550 MHz, operational amplifier (see RHF350 datasheet for further information)
- Mounted components (ready-to-use)
- Material: two-layered FR-4
- PCB thickness: 1.6 mm
- Copper thickness: 35 μm
- Analog connections: SMA
- Supply connections: banana 2 mm

Description

This data brief describes the EVAL-RHF350V1 evaluation board.

This evaluation board is a ready-to-use, configurable hardware which allows designers to efficiently test a target device. A unique PCB is used in different configurations to support the radiation-hardened (rad-hard), operational amplifier devices.

This document shows the components incorporated on the EVAL-RHF350V1 evaluation board and suggests several ways to use the board.

The EVAL-RHF350V1 evaluation board is intended only for evaluation purposes.



Table 1. Evaluation board summary

Evaluation board part number	Device part number	Operation amplifier
EVAL-RHF350V1	RHF350	550 MHz precision signal conditioning

Contents

1	Bill of material	3
2	Device pin connections and description	4
3	Evaluation board schematic	5
4	PCB print out	6
5	Evaluation board description	7
6	Revision history	9

1 Bill of material

Table 2. Bill of material

Designator	Footprint	Part type	Description
C1	1210	100 μ F	Bypass ceramic capacitor on V _{CC}
C3	0805		
C4			
C6	1210		
IC1	FLAT 8	RHF350	DUT
J1	Banana 2 mm	Red	Banana 2 mm supply connectors
J2		Black	
J3		Blue	
J4	SMA	SMA	SMA connector
J5			
J6			
J7			
J8			
R1	0603	50 Ω - 1 %	SMD resistor
R2			
R4		300 Ω - 1 %	
R6			
R8		NC	
R9		0 Ω	
C8		0805	
C2			
C5	0603		
C7			
R3			
R5			
R7			

1. NC = not connected

2 Device pin connections and description

Figure 1. RHF350 pin connections

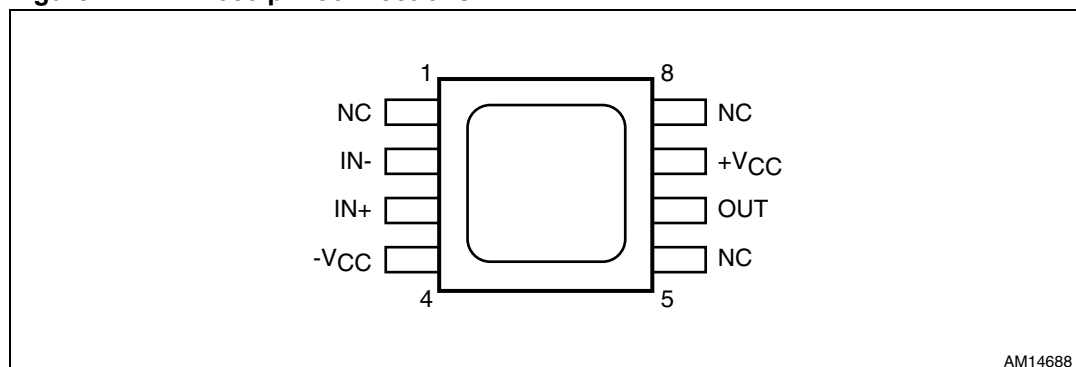
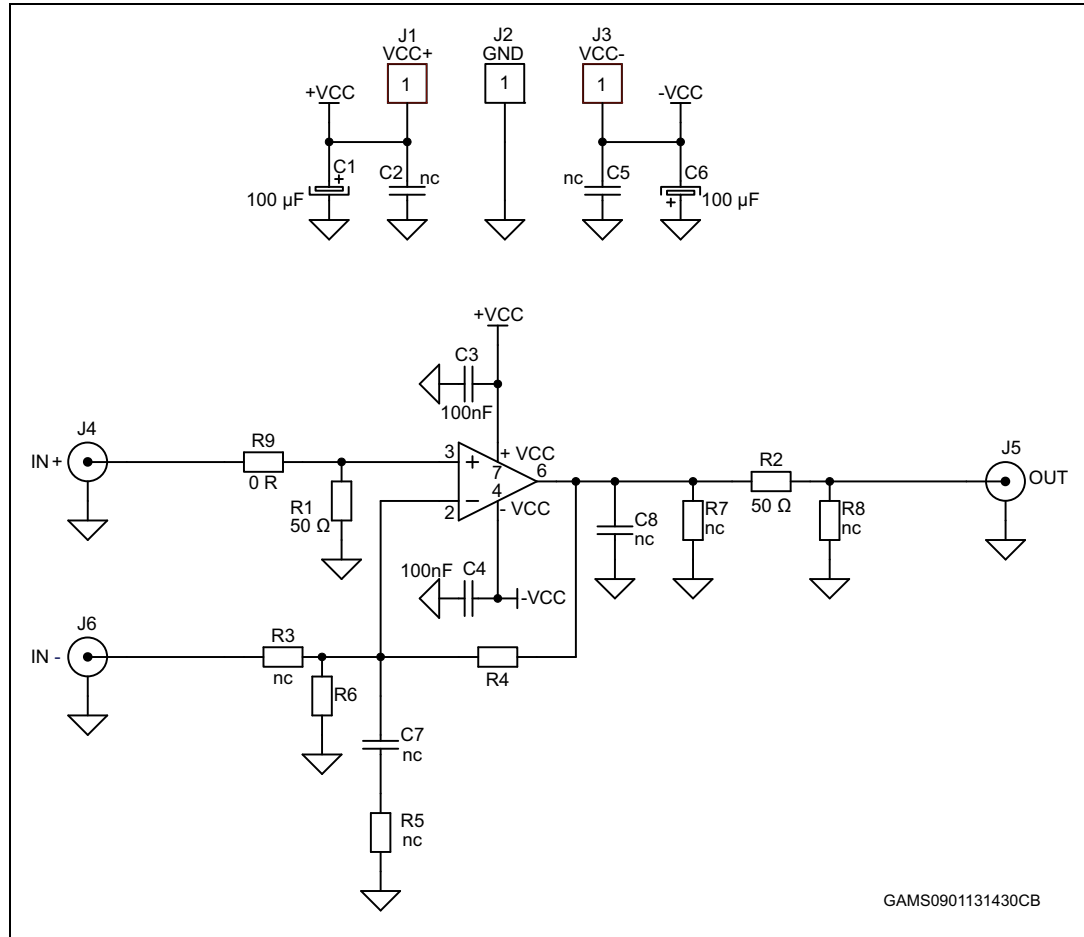

Table 3. RHF350 pin description

Name	Pin number	Description
NC	1, 5, 8	Non connected pins
IN-	2	Negative input pin
IN+	3	Positive input pin
-V _{CC}	4	Negative supply
OUT	6	Output pin
+V _{CC}	7	Positive supply

3 Evaluation board schematic

Figure 2. EVAL-RHF350V1 full layout schematic



GAMS0901131430CB

4 PCB print out

The PCB is a two-layered FR-4 material which is 1.6 mm thick. The copper thickness is 35 μm .

Figure 3. Front layer

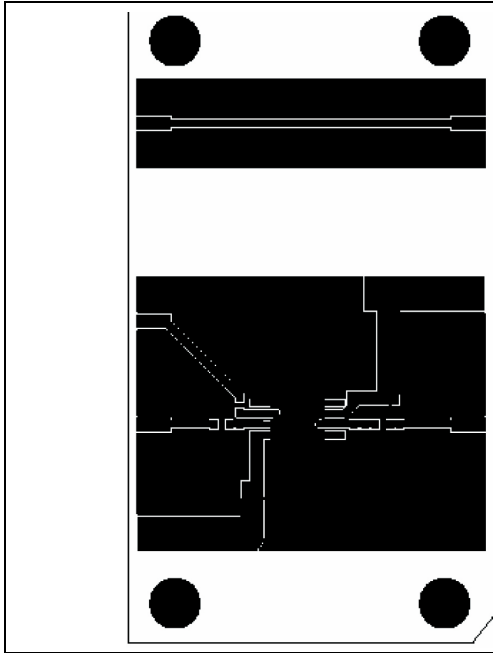

Figure 4. Front drawing

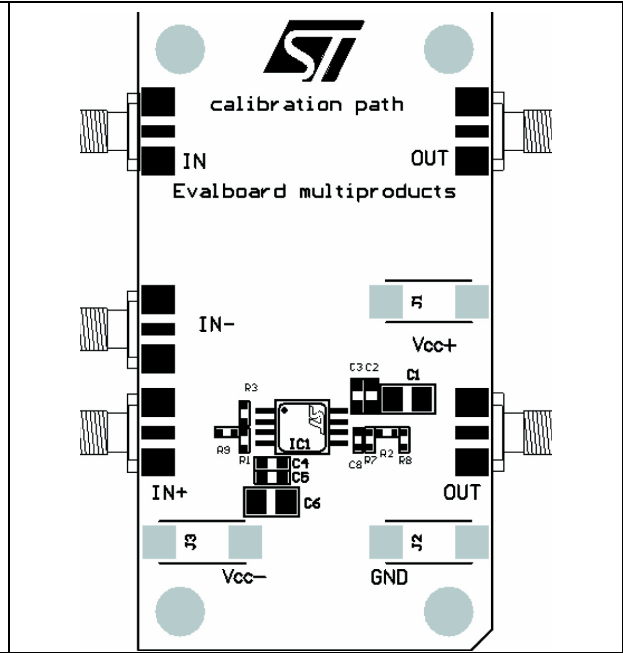

Figure 5. Bottom layer

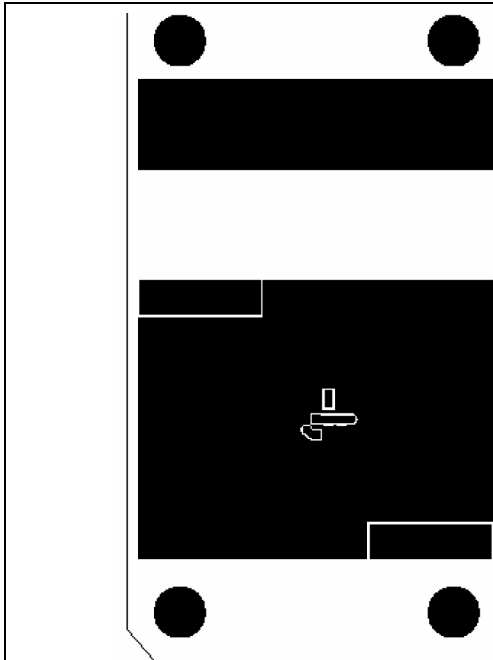
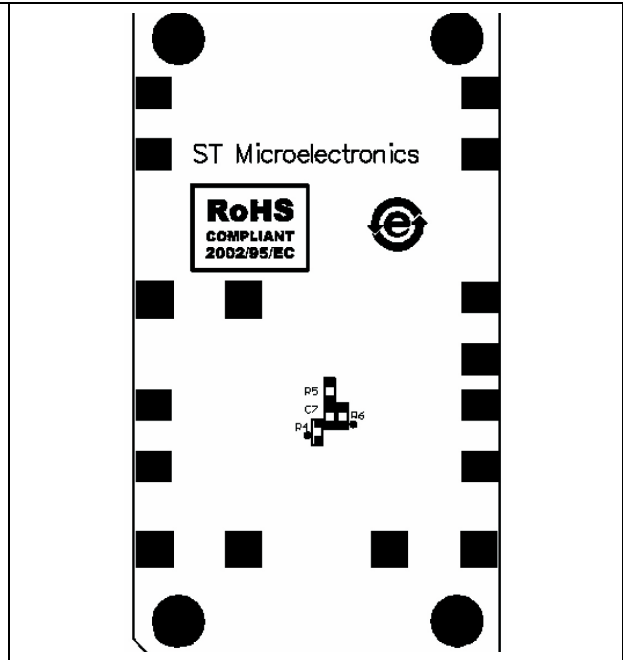

Figure 6. Bottom drawing



5 Evaluation board description

The PCB is designed for 50-ohm generators and receivers. A 50-ohm calibration path can be used for high speed products.

Capacitor C8 can be used to load the output. Capacitor C7 and resistor R5 can be used to stabilize the product.

Pi resistors R7, R2, and R8 are used to adapt impedance between the output load and the hardware tool. For example, to load the device under test (DUT) with 150 Ω when the analyzer is 50 Ω input impedance, use the following equations for each respective resistor:

- R7 = 2.2 k Ω
- R2 = 130 Ω
- R8 = 82 Ω

A 100-nF and a 100- μ F capacitor are soldered onto each supply. A third supply place is kept free in case an additional bypass capacitor is needed.

Resistors (R) mounted on the board are placed to get a positive gain of two by the DUT as shown in [Figure 7](#).

Figure 7. Positive gain of two schematic

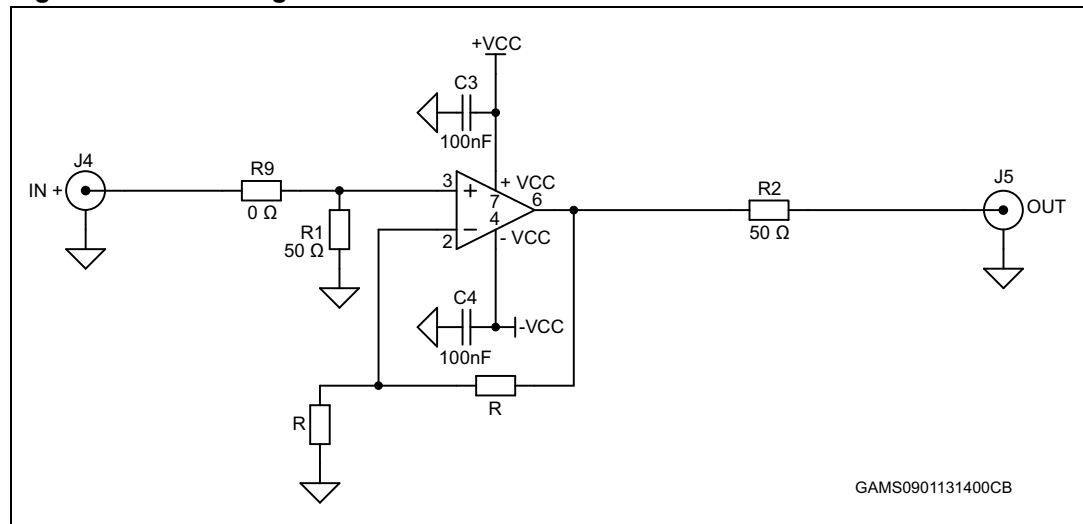

The layout in [Figure 8](#) allows the DUT to be tested with a negative gain.

Figure 8. Negative gain schematic

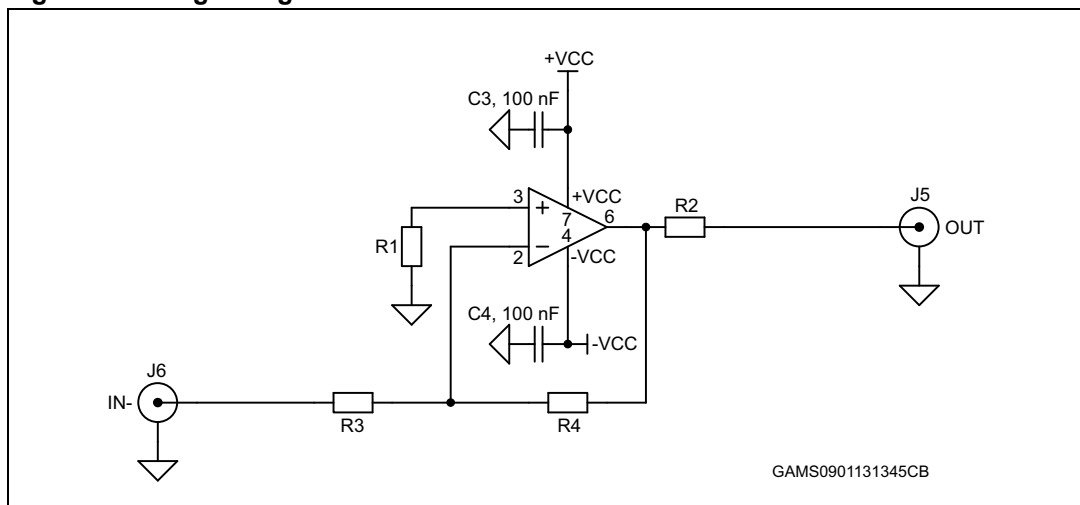

Other configurations such as an integrator or a differentiator can also be used.

6 Revision history

Table 4. Document revision history

Date	Revision	Changes
25-Jan-2013	1	Initial release.

Please Read Carefully:

Information in this document is provided solely in connection with ST products. STMicroelectronics NV and its subsidiaries ("ST") reserve the right to make changes, corrections, modifications or improvements, to this document, and the products and services described herein at any time, without notice.

All ST products are sold pursuant to ST's terms and conditions of sale.

Purchasers are solely responsible for the choice, selection and use of the ST products and services described herein, and ST assumes no liability whatsoever relating to the choice, selection or use of the ST products and services described herein.

No license, express or implied, by estoppel or otherwise, to any intellectual property rights is granted under this document. If any part of this document refers to any third party products or services it shall not be deemed a license grant by ST for the use of such third party products or services, or any intellectual property contained therein or considered as a warranty covering the use in any manner whatsoever of such third party products or services or any intellectual property contained therein.

UNLESS OTHERWISE SET FORTH IN ST'S TERMS AND CONDITIONS OF SALE ST DISCLAIMS ANY EXPRESS OR IMPLIED WARRANTY WITH RESPECT TO THE USE AND/OR SALE OF ST PRODUCTS INCLUDING WITHOUT LIMITATION IMPLIED WARRANTIES OF MERCHANTABILITY, FITNESS FOR A PARTICULAR PURPOSE (AND THEIR EQUIVALENTS UNDER THE LAWS OF ANY JURISDICTION), OR INFRINGEMENT OF ANY PATENT, COPYRIGHT OR OTHER INTELLECTUAL PROPERTY RIGHT.

UNLESS EXPRESSLY APPROVED IN WRITING BY TWO AUTHORIZED ST REPRESENTATIVES, ST PRODUCTS ARE NOT RECOMMENDED, AUTHORIZED OR WARRANTED FOR USE IN MILITARY, AIR CRAFT, SPACE, LIFE SAVING, OR LIFE SUSTAINING APPLICATIONS, NOR IN PRODUCTS OR SYSTEMS WHERE FAILURE OR MALFUNCTION MAY RESULT IN PERSONAL INJURY, DEATH, OR SEVERE PROPERTY OR ENVIRONMENTAL DAMAGE. ST PRODUCTS WHICH ARE NOT SPECIFIED AS "AUTOMOTIVE GRADE" MAY ONLY BE USED IN AUTOMOTIVE APPLICATIONS AT USER'S OWN RISK.

Resale of ST products with provisions different from the statements and/or technical features set forth in this document shall immediately void any warranty granted by ST for the ST product or service described herein and shall not create or extend in any manner whatsoever, any liability of ST.

ST and the ST logo are trademarks or registered trademarks of ST in various countries.

Information in this document supersedes and replaces all information previously supplied.

The ST logo is a registered trademark of STMicroelectronics. All other names are the property of their respective owners.

© 2013 STMicroelectronics - All rights reserved

STMicroelectronics group of companies

Australia - Belgium - Brazil - Canada - China - Czech Republic - Finland - France - Germany - Hong Kong - India - Israel - Italy - Japan - Malaysia - Malta - Morocco - Philippines - Singapore - Spain - Sweden - Switzerland - United Kingdom - United States of America

www.st.com