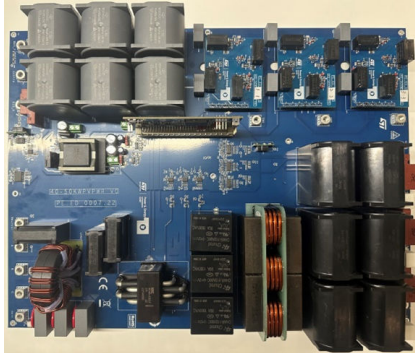


50 kW three-phase T-type DC/AC inverter reference design based on the STM32H743ZG MCU



Fully assembled board developed for performance evaluation only, **not available for sale**

Features

- DC/AC inverter with three-phase T-type topology
- Input range: DC voltage from 650 to 850 VDC
- Output range: AC voltage from 310 to 476 VAC
- Maximum power: 50 kW
- Peak efficiency >98.89% (rated 800 VDC)
- High switching frequency operation (40 kHz)
- Power factor (PF): 0.8 lead ~ 0.8 lag
- PQ/PF control
- THD lower than 3% at full load operation (rated 800 VDC)
- Overcurrent and overvoltage protection

Description

This 50 kW T-type DC/AC inverter reference design introduces a complete ST's digital power solution for high power three-phase DC/AC inverter applications based on the three levels T-type topology. This reference design topology is mostly used for industrial photovoltaic (PV) solar applications and commercial energy storage applications.

This reference design achieves larger than 98.89% peak efficiency by utilizing ST's 1200 V, 9.5 mΩ and 750 V, 6 mΩ T-type SiC module, which is in a ACEPACK2 package. It features fully digital control, with the [STM32H743ZG](#) mixed-signal high-performance microcontroller providing full control of the output power and the task to manage the grid connection procedure. It provides high bandwidth continuous conduction mode (CCM) current regulation for maximum power quality in terms of total harmonic distortion (THD) and power factor (PF).

Product summary	
50 kW T-type DC/AC inverter reference design based on the STM32H743ZG digital controller	STDES-50KWTTTPVI
Mainstream Arm Cortex®-M7 MCU 480 MHz with 1024 Kbytes of flash memory	STM32H743ZGT6
Silicon carbide module 1200 V, 9.5 mΩ and 750 V, 6 mΩ typ 100 A in ACEPACK2 package	A2U8M12W3-FC
Galvanically isolated 4 A single gate driver for SiC MOSFETs	STGAP2SICSC
Applications	Solar inverters (string and central) Battery storage systems for commercial

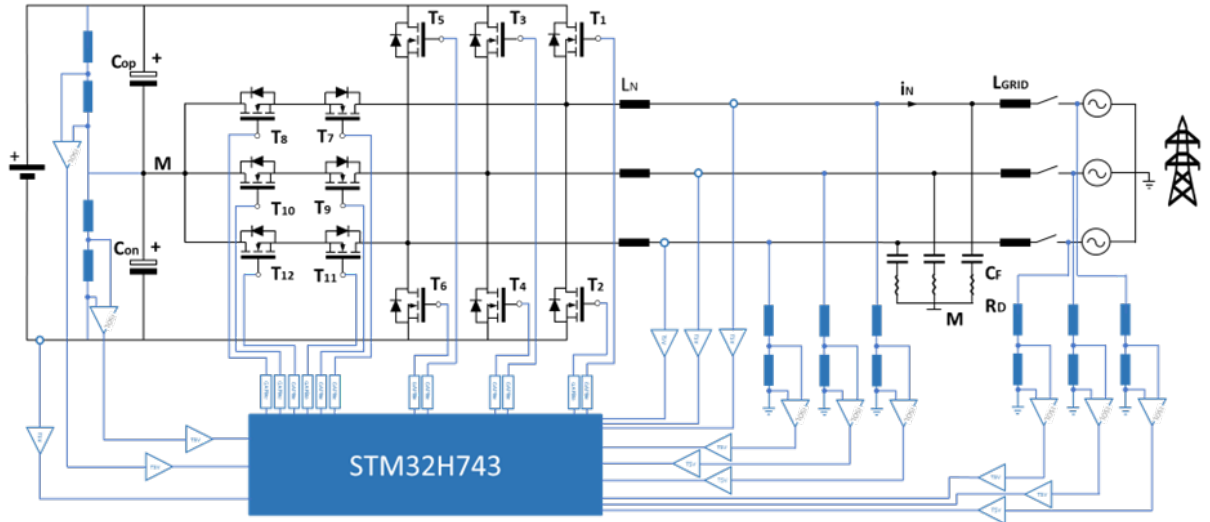
1 Electrical specifications

Table 1. Electrical characteristics

Symbol	Description	Min.	Typ.	Max.	Units	Comments
V _{in}	Input voltage	650	800	850	Vrms	-
f _{AC}	Output AC frequency	45	50	55	Hz	-
V _{out}	Output Line-Line AC voltage	310	380	476	V	-
P _{out}	Output power	-	-	50	kW	-
I _{out}	Output current	-	-	76	A	V _{AC(L-L)} = 380 V
η	Peak efficiency	-	-	98.89	%	V _{in} = 800 V V _{AC(L-L)} = 380 V
		-	-	99.1	%	V _{in} = 650 V V _{AC(L-L)} = 380 V
iTHD	Total harmonic distortion	-	<3	-	%	At full load (rated 800 Vdc)
PF	Power Factor	-	0.99	-	-	At full load
	Power Factor Range	-	0.8	-	-	0.8 lead ~ 0.8 lag
I _{out_OCP}	Output current protection	-	-	180	A	Hardware
BUSOVP	Input voltage protection	-	-	600	V	Half of the input voltage

2 Platform overview

Figure 1. System architecture of three phase T-type DC/AC inverter



3 Schematic diagrams

Figure 2. STDES-50KWPVDRV gate driver board - circuit schematic (1 of 2)

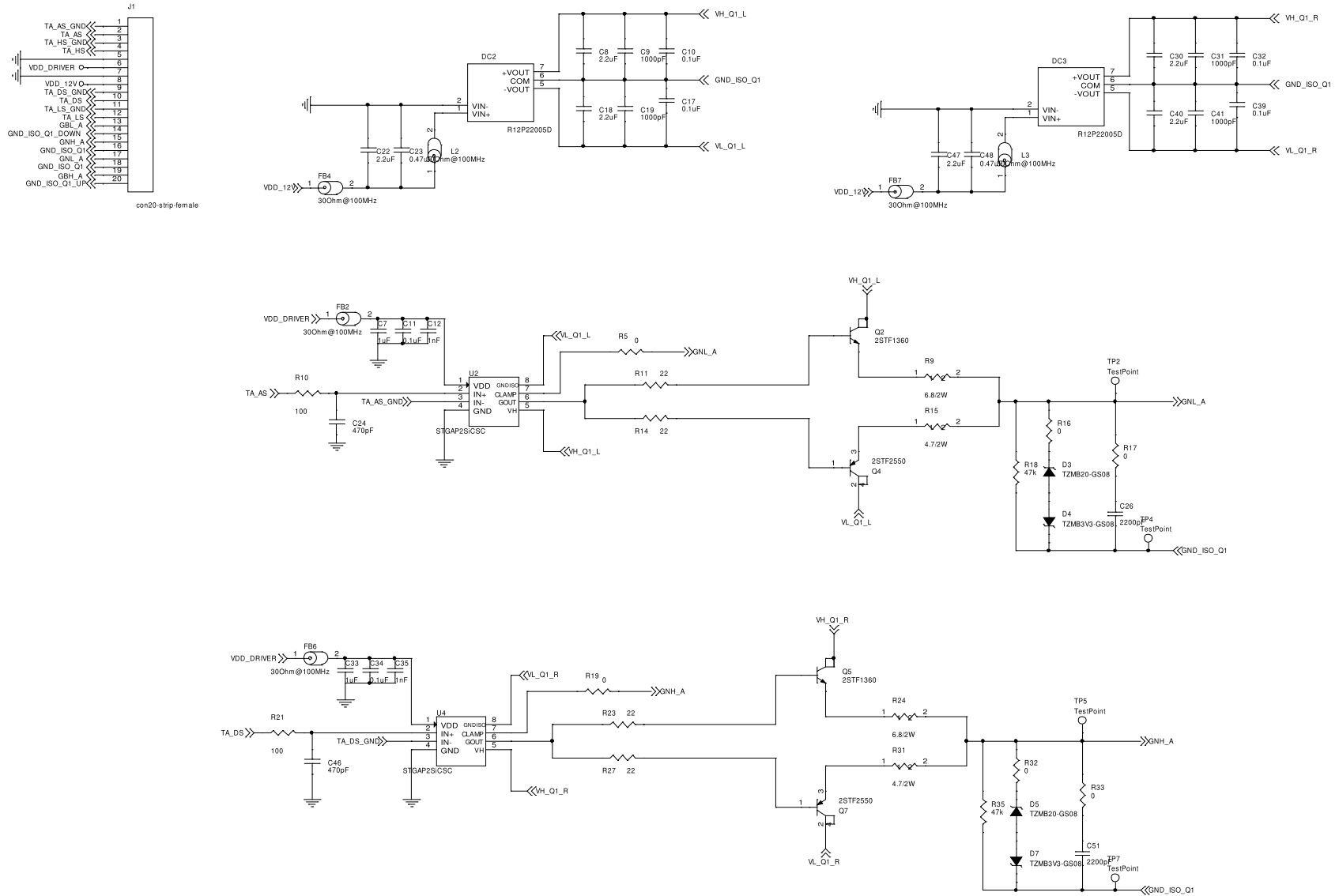


Figure 3. STDES-50KWPVDRV gate driver board - circuit schematic (2 of 2)

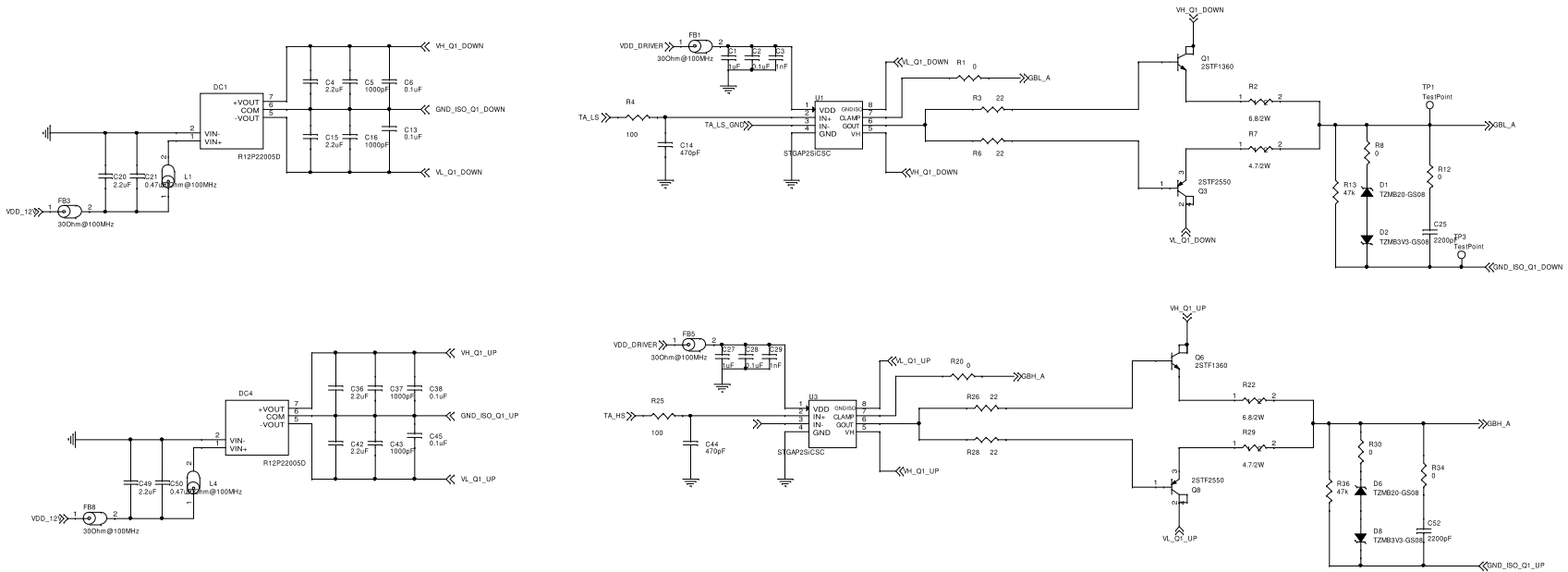


Figure 4. STDES-50KWPVWR main power board - circuit schematic (1 of 13)

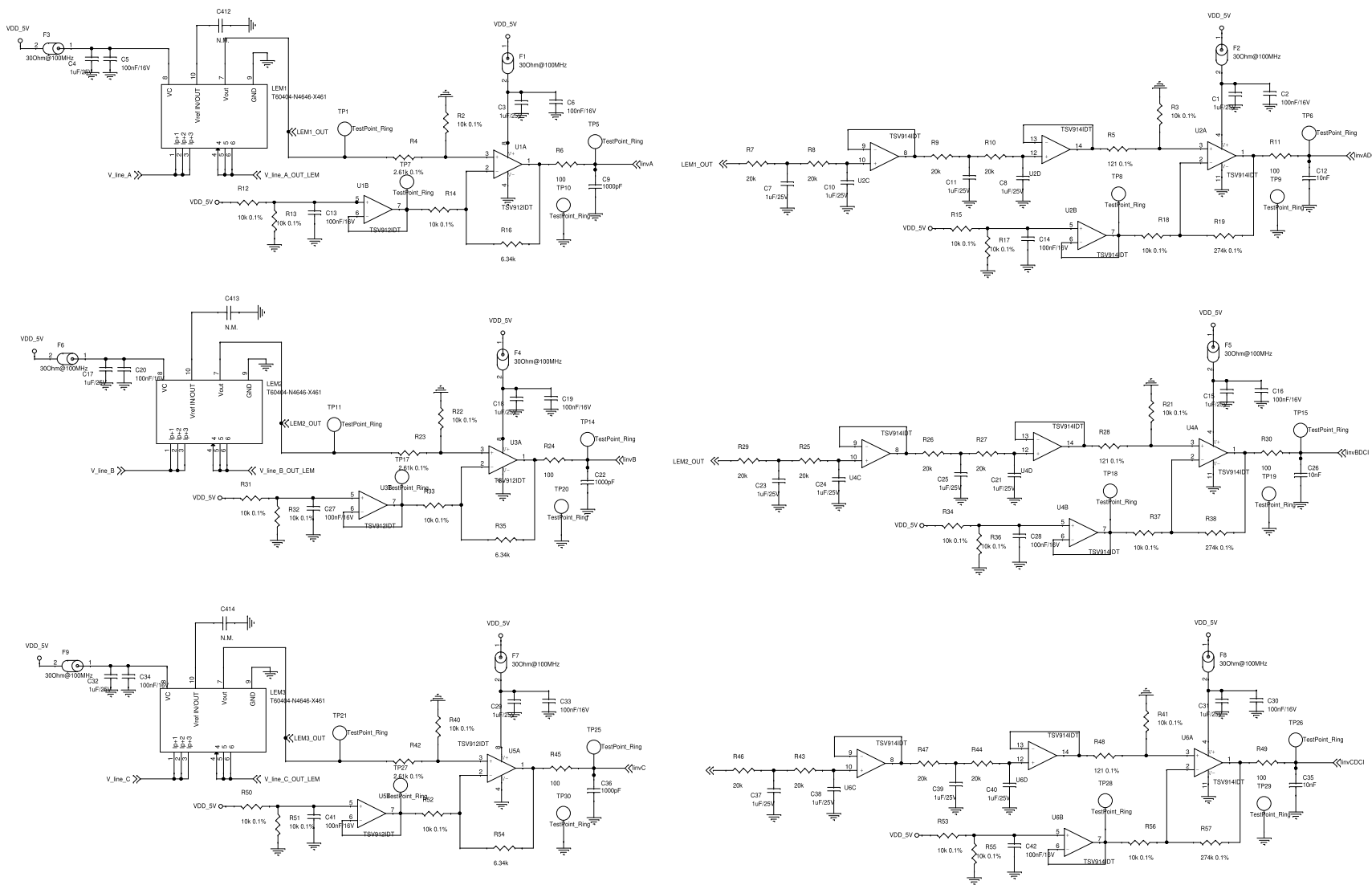


Figure 5. STDES-50KWPVWR main power board - circuit schematic (2 of 13)

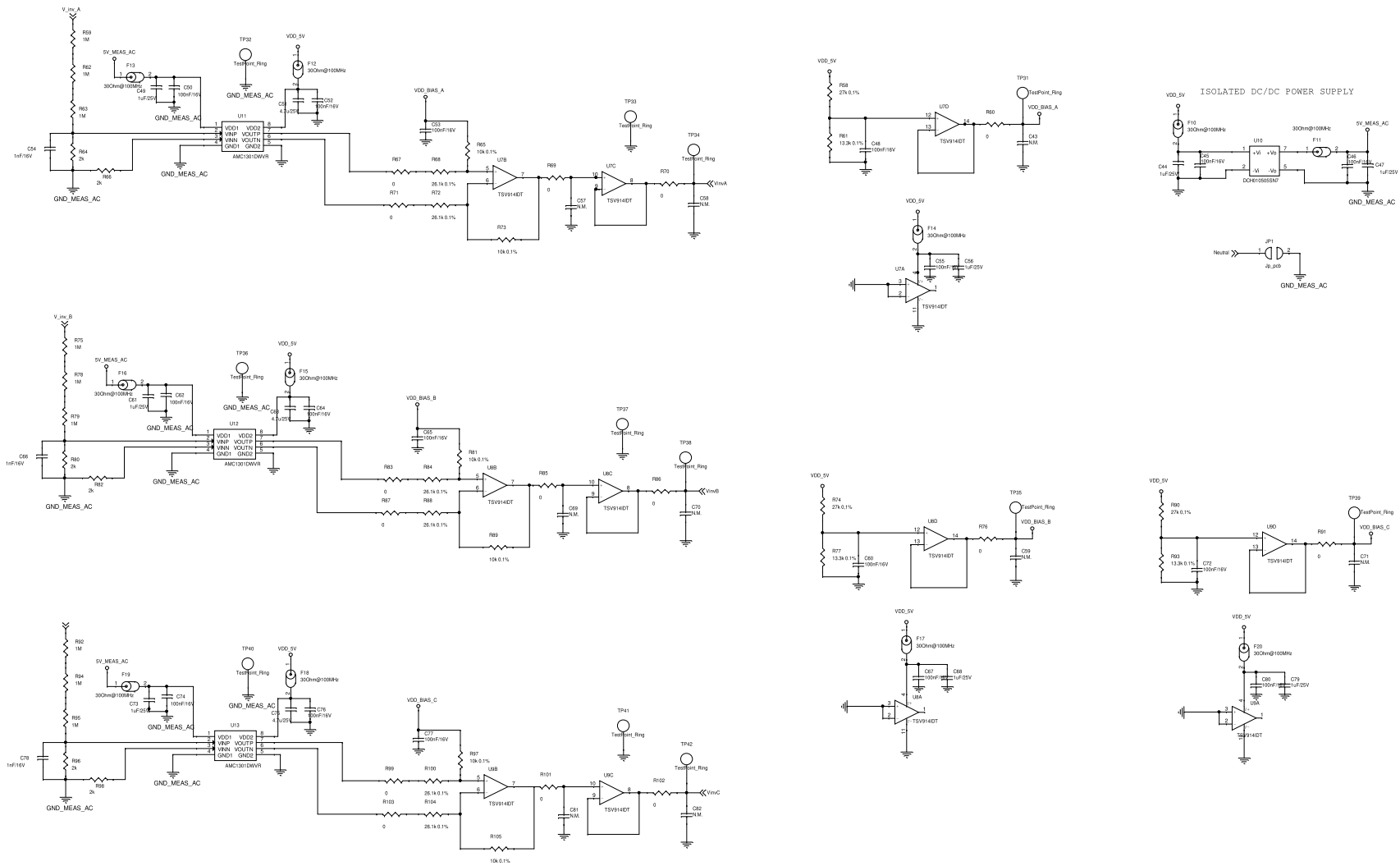


Figure 6. STDES-50KWPVWR main power board - circuit schematic (3 of 13)

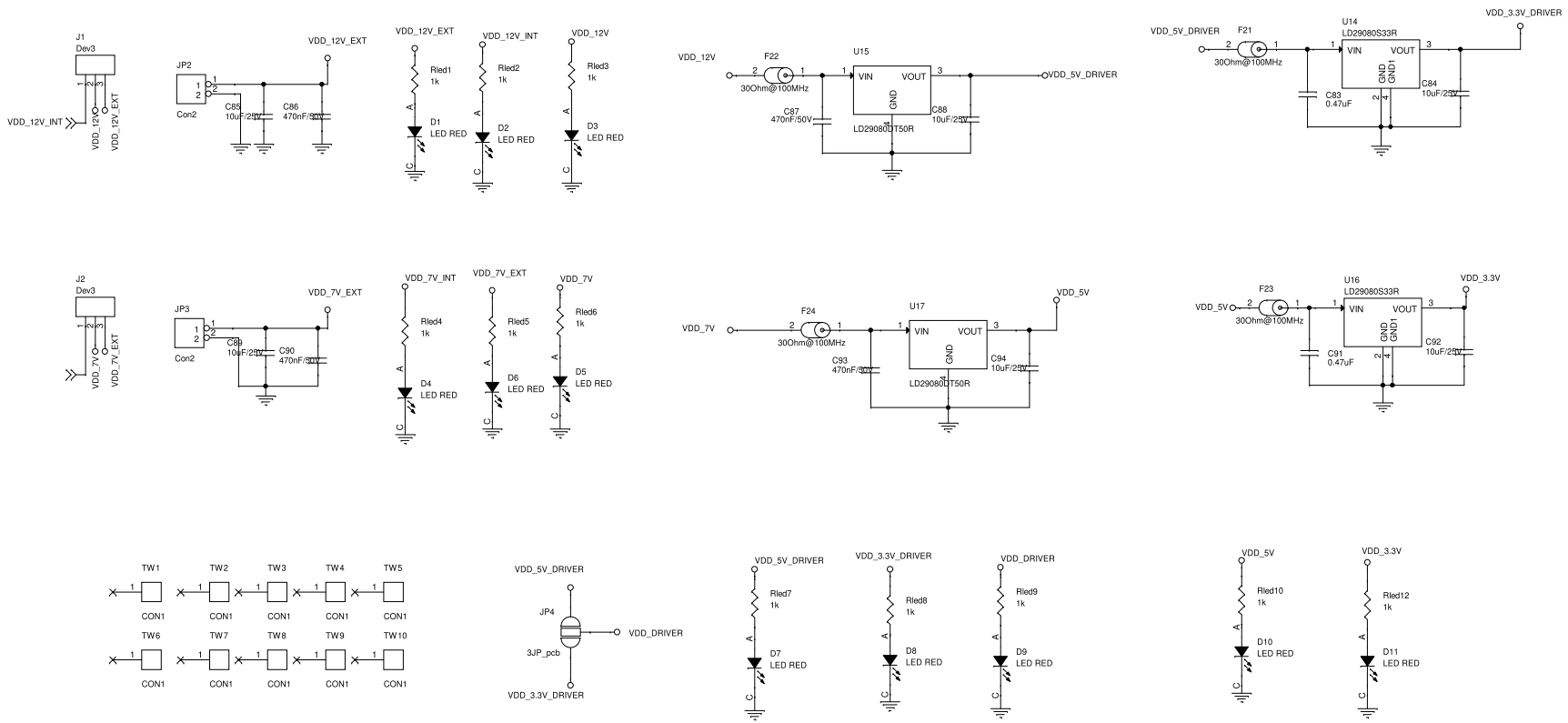


Figure 7. STDES-50KWPVWR main power board - circuit schematic (4 of 13)

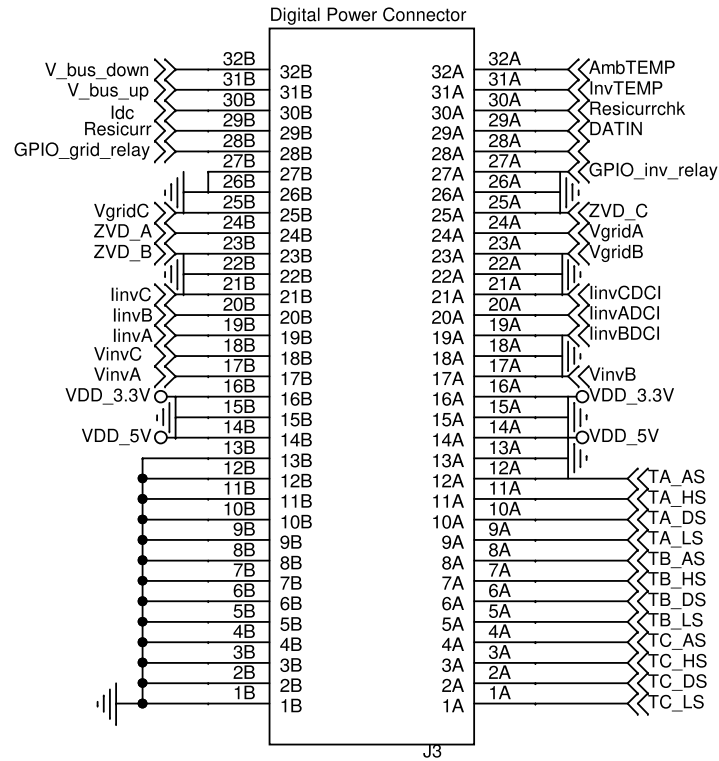


Figure 8. STDES-50KWPVWR main power board - circuit schematic (5 of 13)

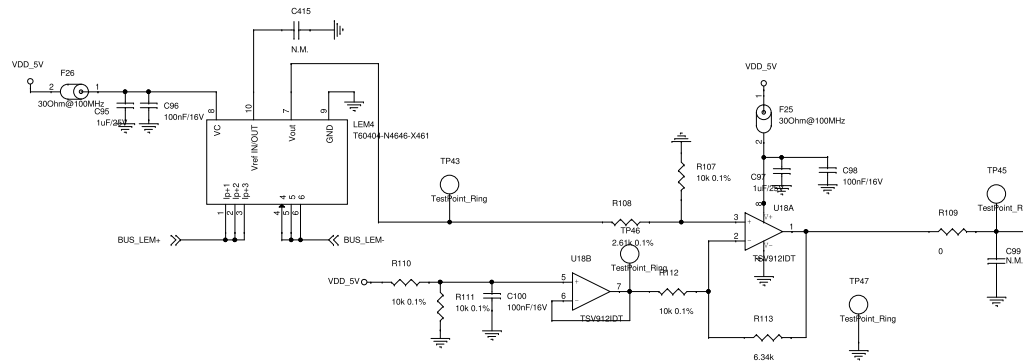


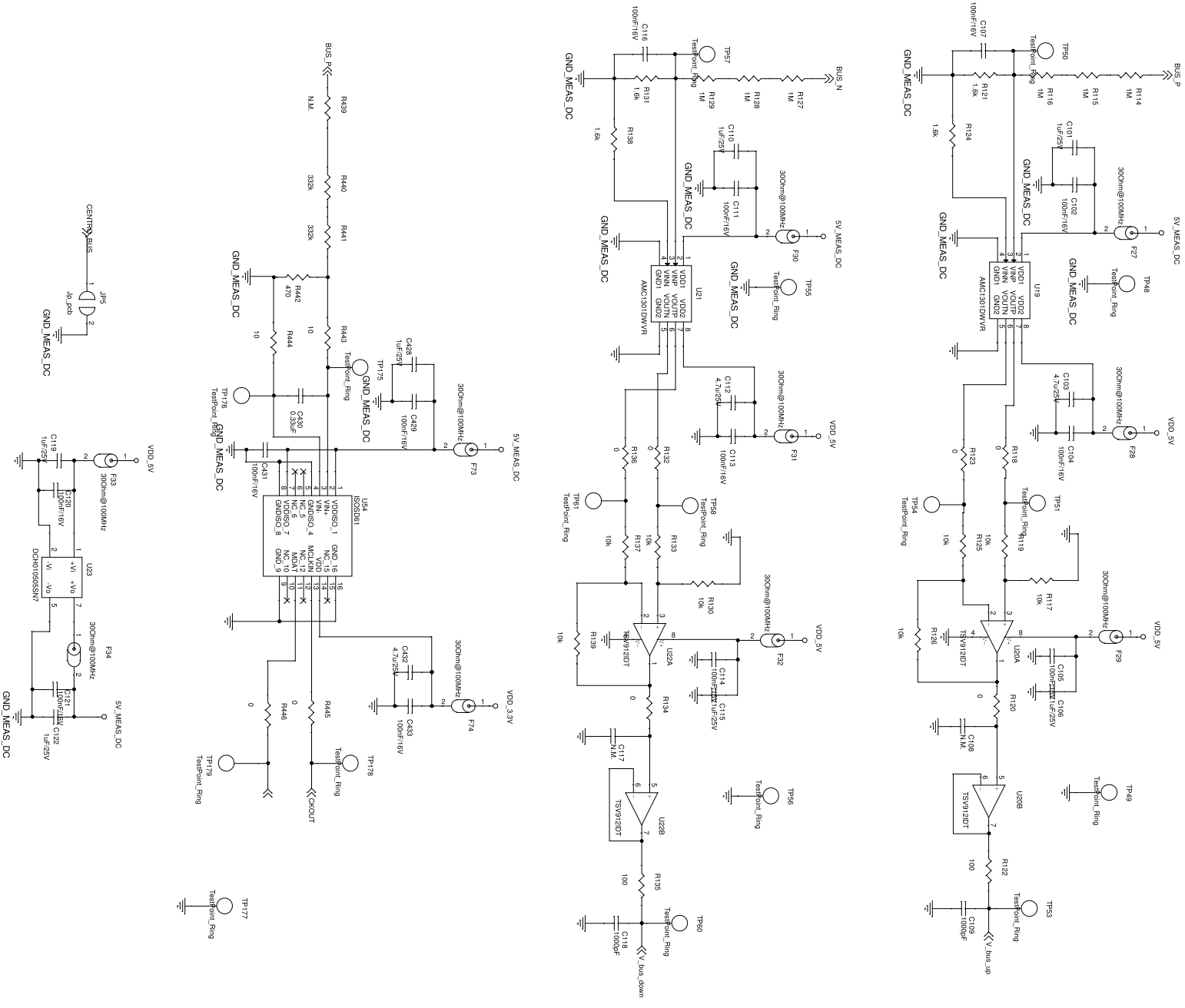
Figure 9. STDES-50KWVPWR main power board - circuit schematic (6 of 13)


Figure 10. STDES-50KWPVPWR main power board - circuit schematic (7 of 13)

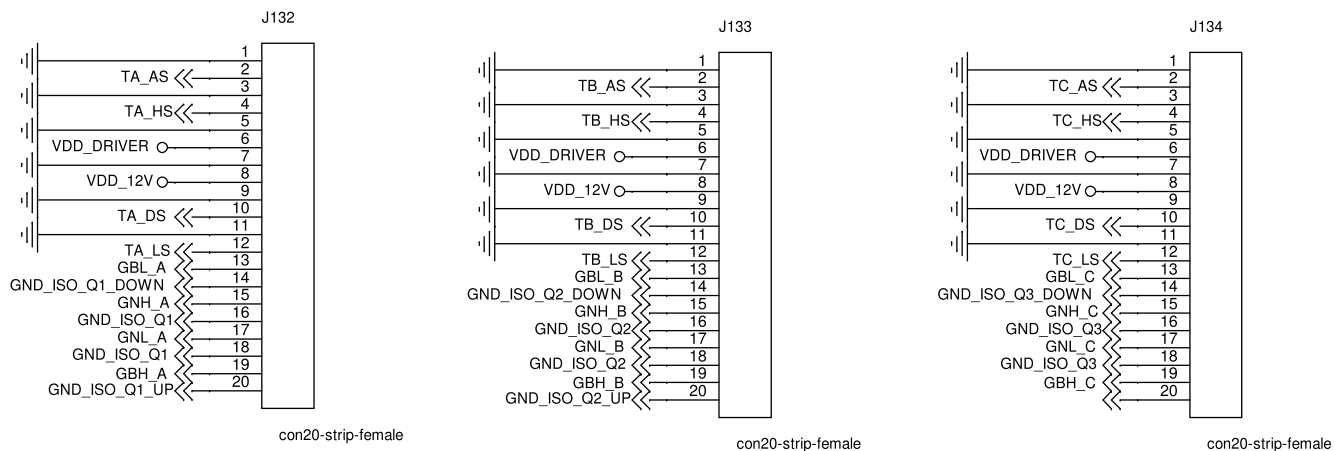


Figure 11. STDES-50KWPVPR main power board - circuit schematic (8 of 13)

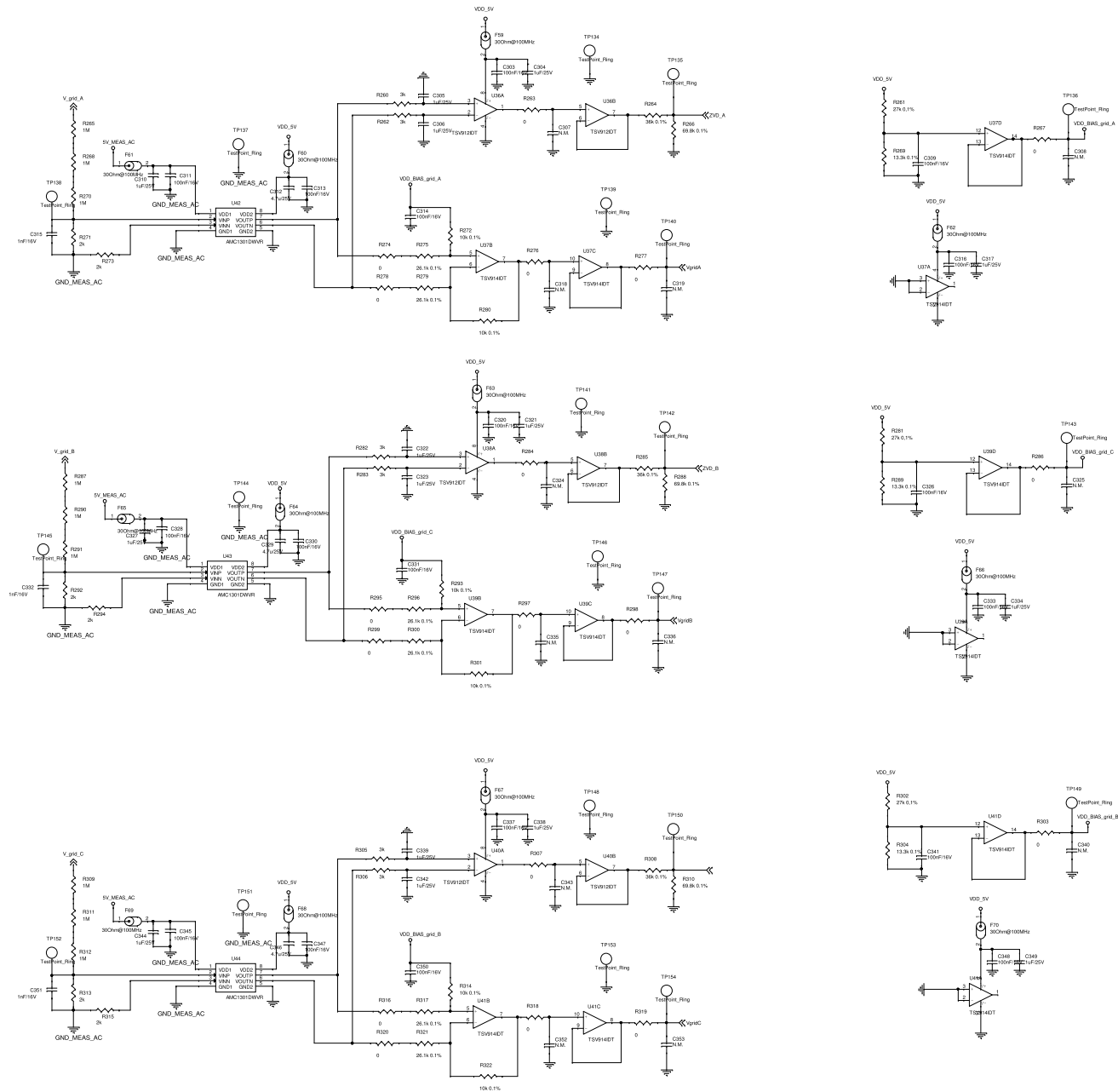


Figure 13. STDES-50KWPVWR main power board - circuit schematic (10 of 13)

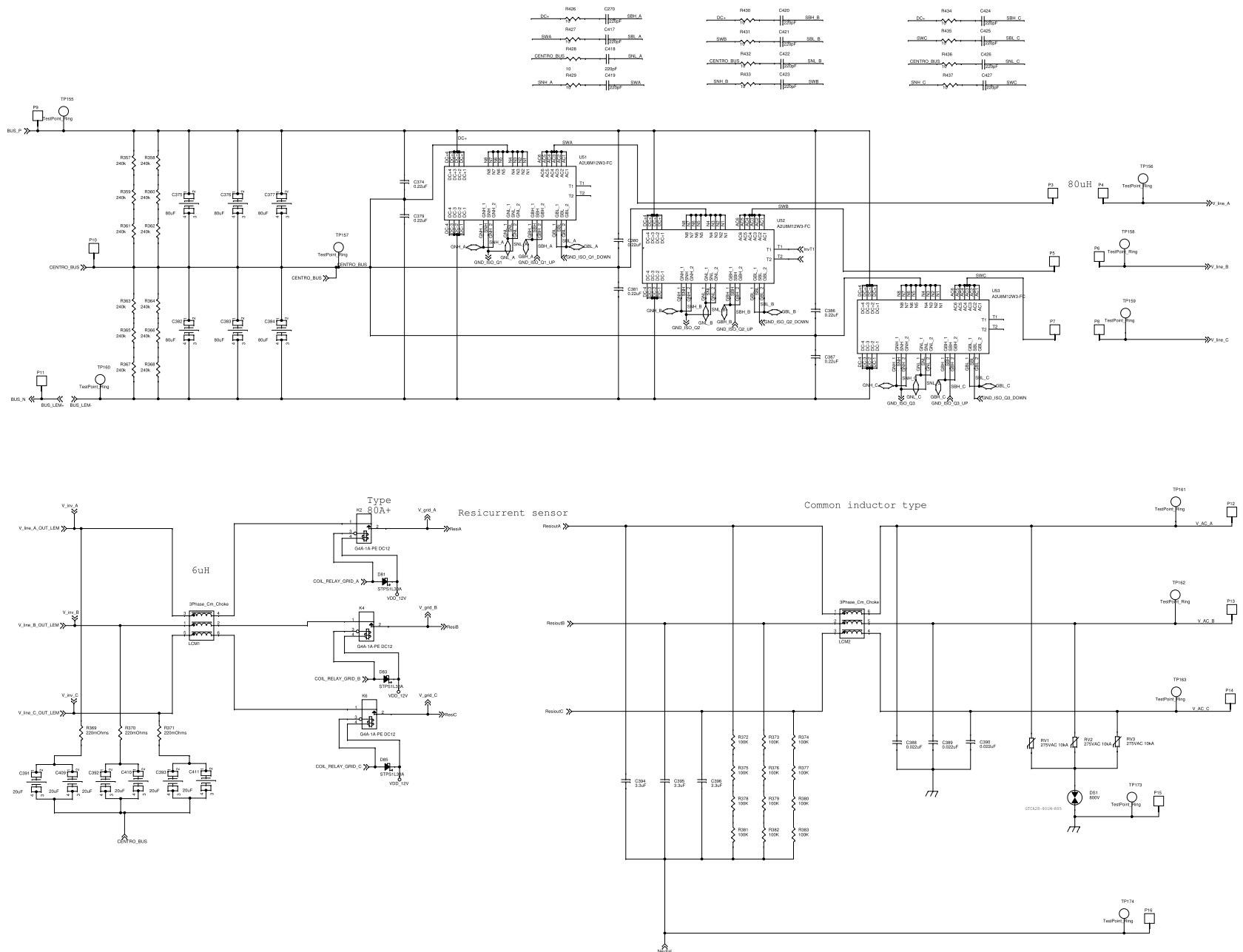


Figure 14. STDES-50KWPVWR main power board - circuit schematic (11 of 13)

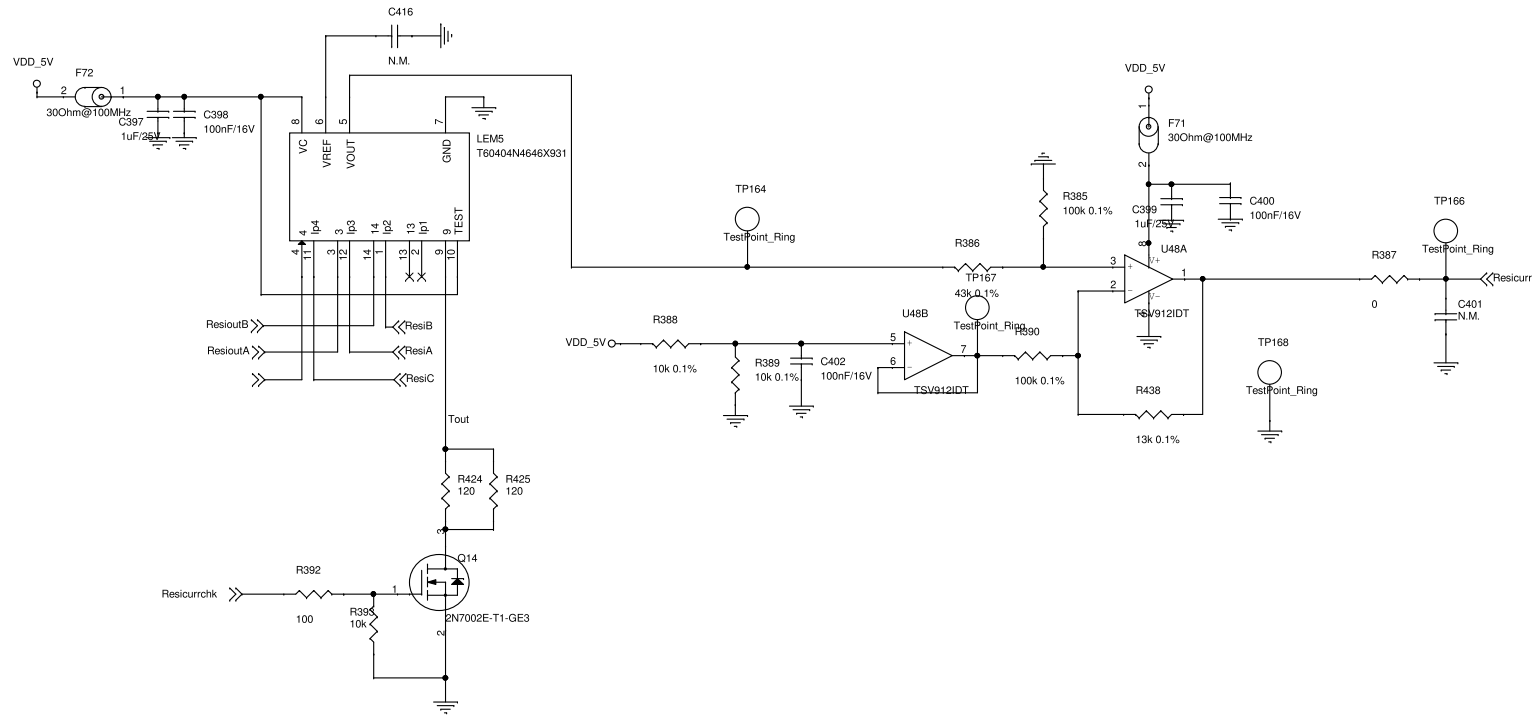


Figure 15. STDES-50KWPVWR main power board - circuit schematic (12 of 13)

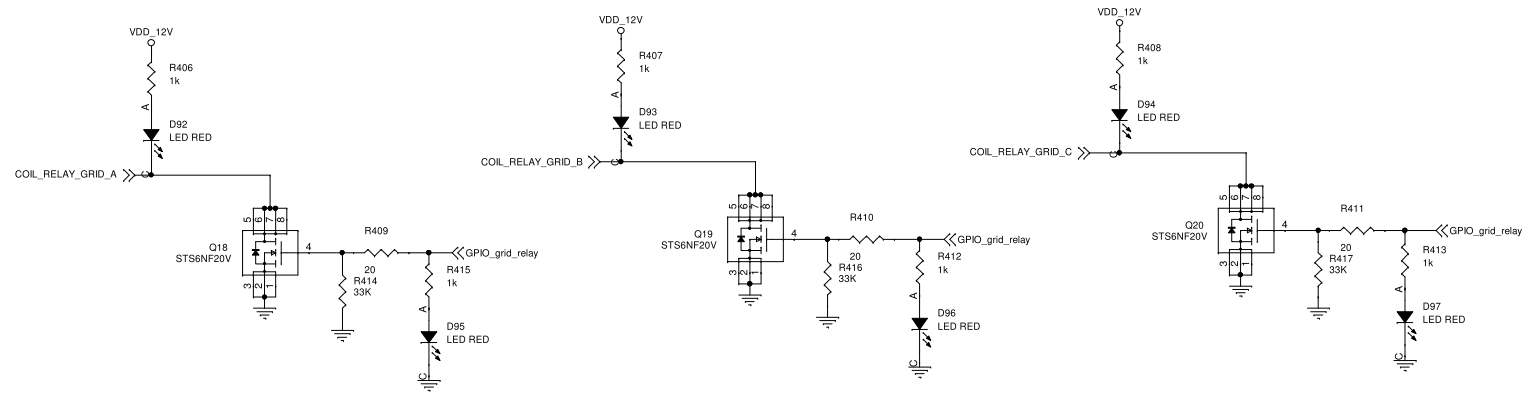


Figure 16. STDES-50KWPVWR main power board - circuit schematic (13 of 13)

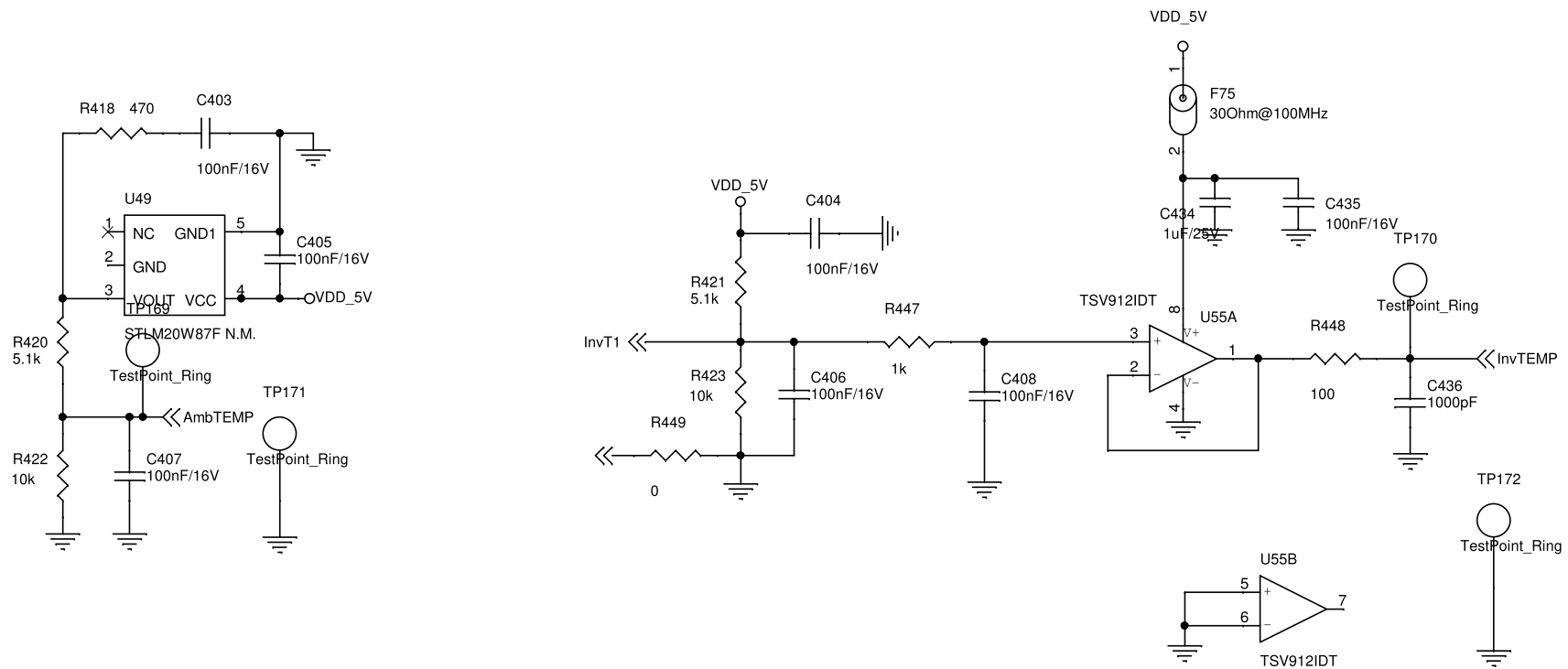


Figure 17. STDES-H743CTRL control board - circuit schematic (1 of 5)

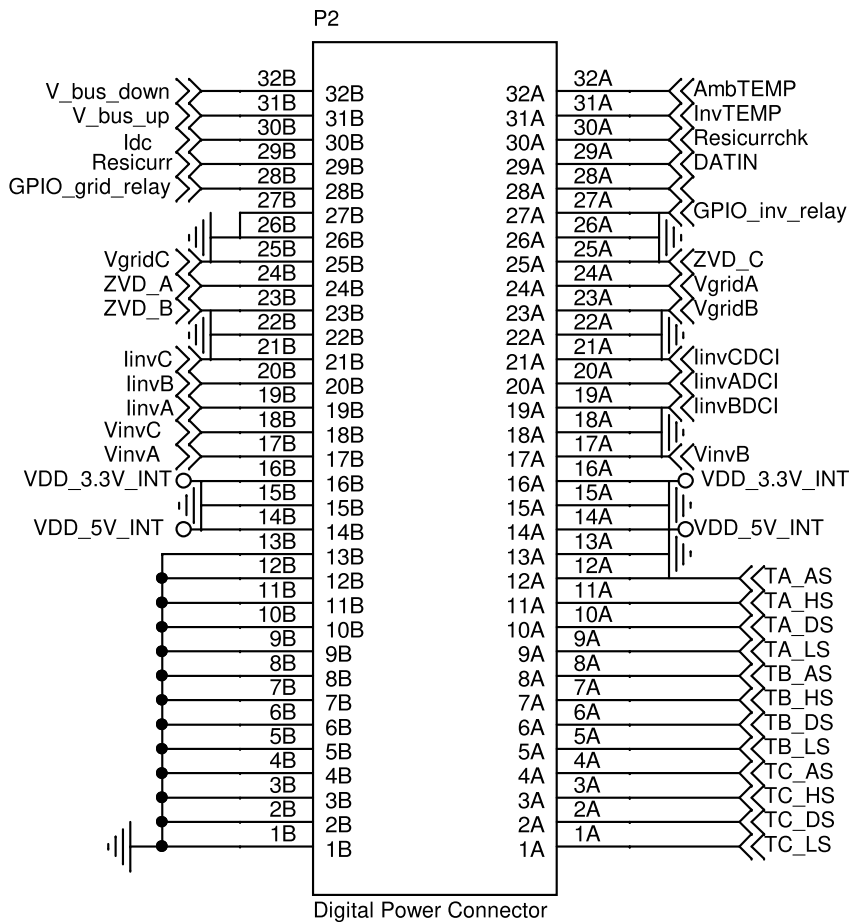


Figure 18. STDES-H743CTRL control board - circuit schematic (2 of 5)

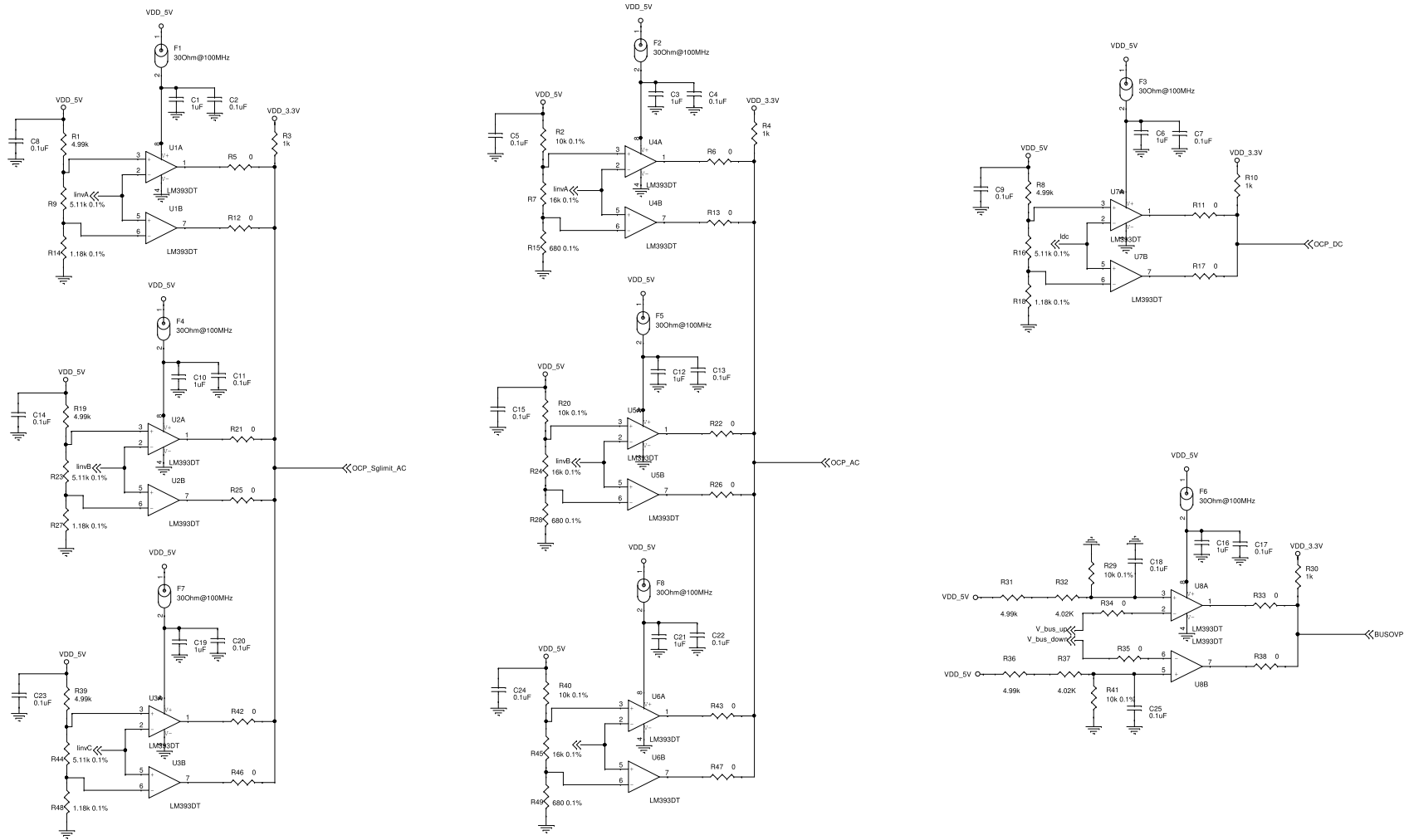


Figure 20. STDES-H743CTRL control board - circuit schematic (4 of 5)

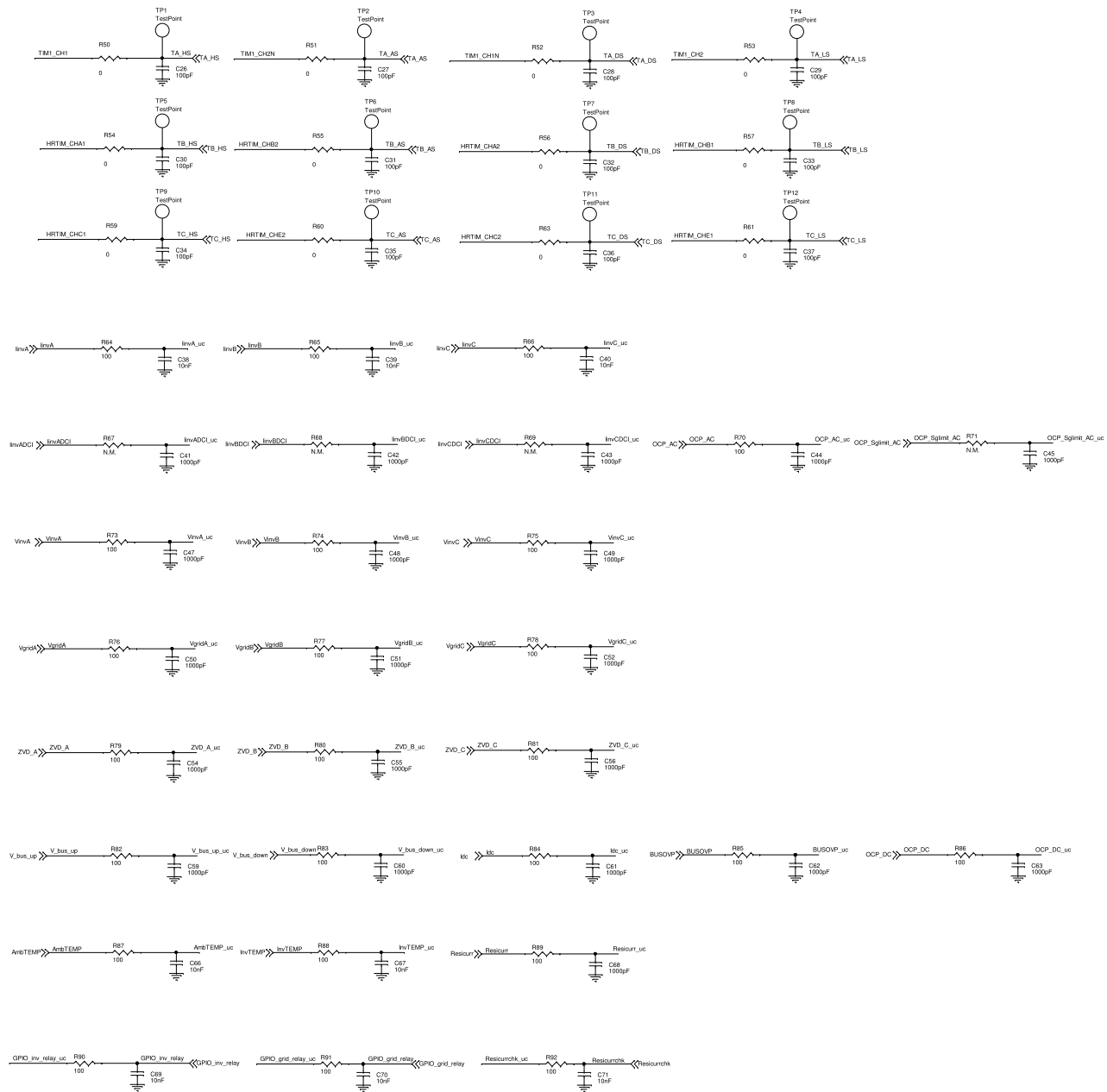
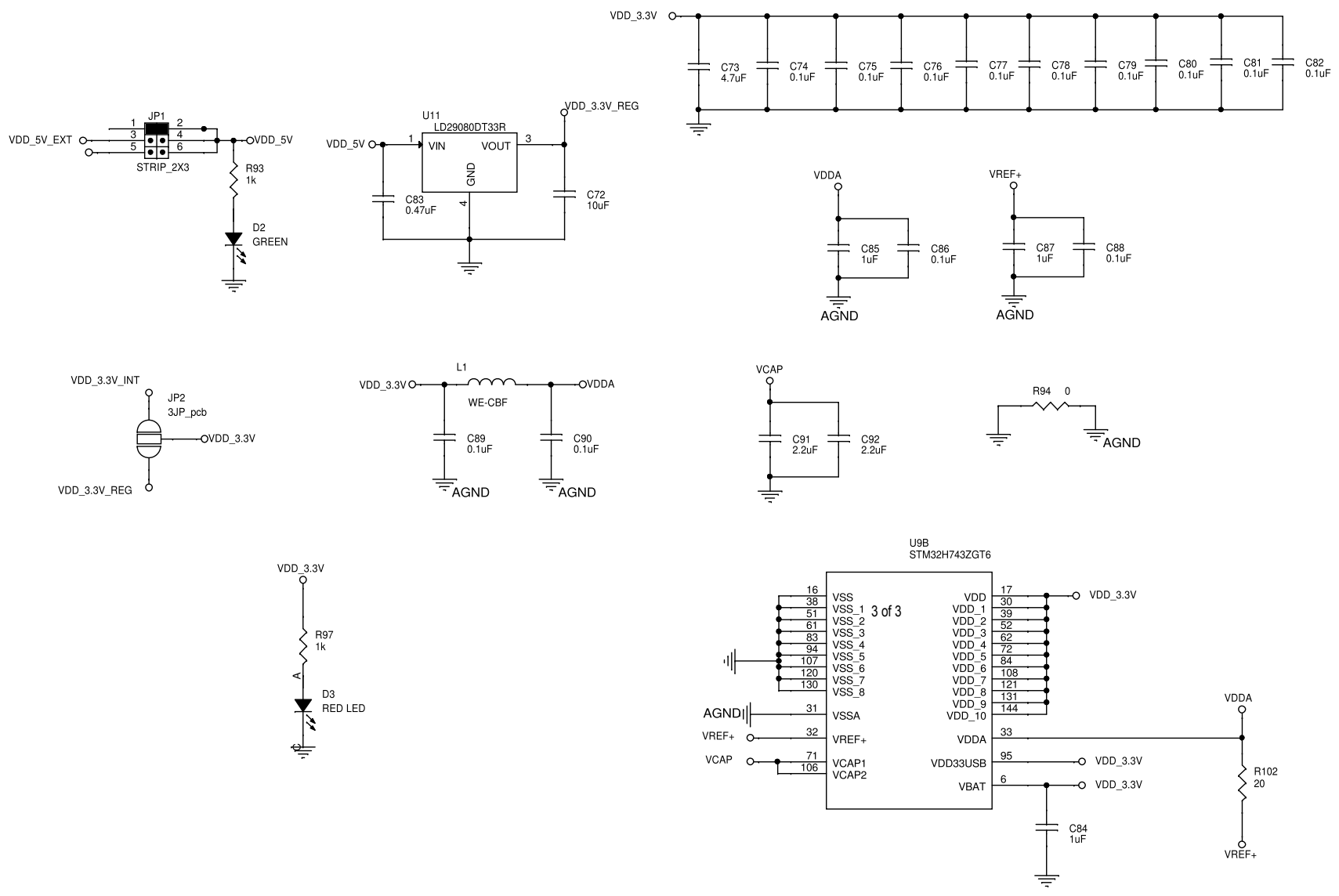


Figure 21. STDES-H743CTRL control board - circuit schematic (5 of 5)



Revision history

Table 2. Document revision history

Date	Revision	Changes
06-Mar-2026	1	Initial release.

IMPORTANT NOTICE – READ CAREFULLY

STMicroelectronics NV and its subsidiaries (“ST”) reserve the right to make changes, corrections, enhancements, modifications, and improvements to ST products and/or to this document at any time without notice.

In the event of any conflict between the provisions of this document and the provisions of any contractual arrangement in force between the purchasers and ST, the provisions of such contractual arrangement shall prevail.

The purchasers should obtain the latest relevant information on ST products before placing orders. ST products are sold pursuant to ST’s terms and conditions of sale in place at the time of order acknowledgment.

The purchasers are solely responsible for the choice, selection, and use of ST products and ST assumes no liability for application assistance or the design of the purchasers’ products.

No license, express or implied, to any intellectual property right is granted by ST herein.

Resale of ST products with provisions different from the information set forth herein shall void any warranty granted by ST for such product.

If the purchasers identify an ST product that meets their functional and performance requirements but that is not designated for the purchasers’ market segment, the purchasers shall contact ST for more information.

ST and the ST logo are trademarks of ST. For additional information about ST trademarks, refer to www.st.com/trademarks. All other product or service names are the property of their respective owners.

Information in this document supersedes and replaces information previously supplied in any prior versions of this document.

© 2026 STMicroelectronics – All rights reserved