

LSM6DSV320X adapter board for a standard DIL24 socket

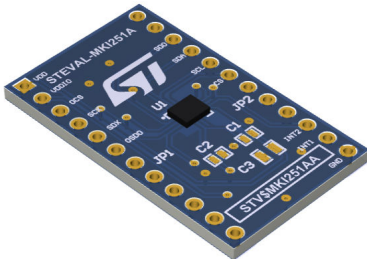

Features

- Complete [LSM6DSV320X](#) pinout for a standard DIL 24 socket
- Fully compatible with [STEVAL-MKI109D](#) evaluation platform
- RoHS compliant

Description

The [STEVAL-MKI251A](#) is an adapter board designed to facilitate the evaluation the [LSM6DSV320X](#) 6-axis IMU (inertial measurement unit).

The board offers an effective solution for fast system prototyping and device evaluation directly within the user's own application.

The [STEVAL-MKI251A](#) can be plugged into a standard DIL 24 socket. The adapter provides the complete [LSM6DSV320X](#) pinout and comes ready-to-use with the required decoupling capacitors on the VDD power supply line.

This adapter is supported by [STEVAL-MKI109D](#) evaluation platform which includes a high performance 32-bit microcontroller functioning as a bridge between the sensor and a PC, on which it is possible to use the downloadable [MEMS Studio](#) graphical user interface, or dedicated software routines for customized applications.

The adapter board can be also plugged in other boards like [STEVAL-MKBOXPRO](#) and [X-NUCLEO-IKS4A1](#).

Product summary	
LSM6DSV320X adapter board for a standard DIL24 socket	STEVAL-MKI251A
9-axis IMU (inertial measurement unit) with high-g accelerometer, embedded AI and sensor fusion	LSM6DSV320X
Professional MEMS tool: evaluation board for all ST MEMS sensors	STEVAL-MKI109D
SensorTile.box PRO with multi-sensors and wireless connectivity for any intelligent IoT node	STEVAL-MKBOXPRO
Application	Sensing

1 Schematic diagrams

Figure 1. STEVAL-MKI247A schematic

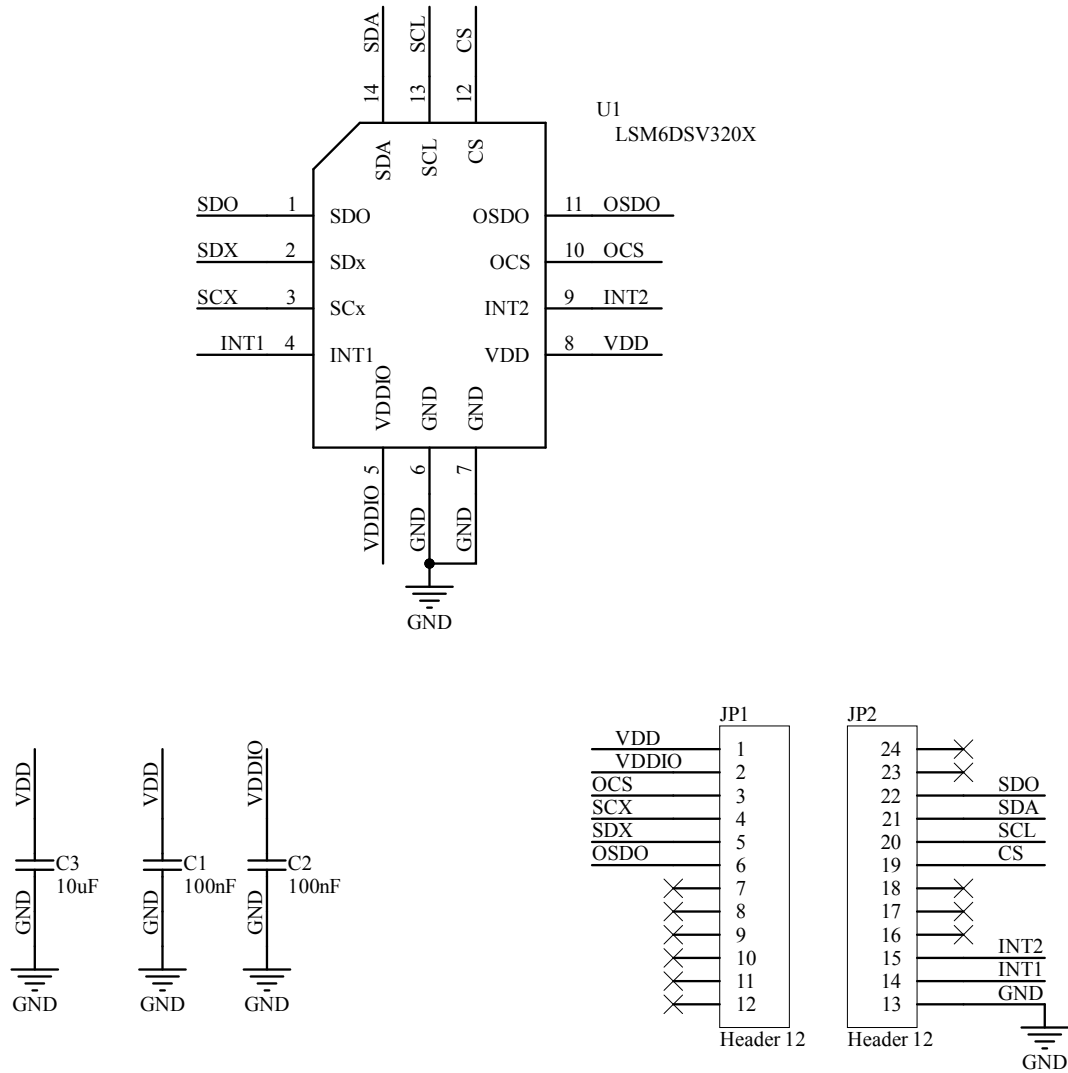

Revision history

Table 1. Document revision history

Date	Revision	Changes
13-Feb-2025	1	Initial release.

IMPORTANT NOTICE – READ CAREFULLY

STMicroelectronics NV and its subsidiaries (“ST”) reserve the right to make changes, corrections, enhancements, modifications, and improvements to ST products and/or to this document at any time without notice. Purchasers should obtain the latest relevant information on ST products before placing orders. ST products are sold pursuant to ST’s terms and conditions of sale in place at the time of order acknowledgment.

Purchasers are solely responsible for the choice, selection, and use of ST products and ST assumes no liability for application assistance or the design of purchasers’ products.

No license, express or implied, to any intellectual property right is granted by ST herein.

Resale of ST products with provisions different from the information set forth herein shall void any warranty granted by ST for such product.

ST and the ST logo are trademarks of ST. For additional information about ST trademarks, refer to www.st.com/trademarks. All other product or service names are the property of their respective owners.

Information in this document supersedes and replaces information previously supplied in any prior versions of this document.

© 2025 STMicroelectronics – All rights reserved