

## Evaluation board based on VL53L9CX Time of Flight sensor



### Features

- Evaluation board based on the VL53L9CX for STM32 Nucleo
  - VL53L9CX is a ToF 3D lidar all-in-one module with high resolution of 2.3 K zones
- Equipped with MIPI and I3C interfaces
- Compatible with various platforms (STM32 Discovery kits and Nucleo boards, RPI, Rockchip)

### Description

The [STEVAL-VL53L9](#) includes one board, which can be easily integrated into the customer devices.

The developer can use the [STEVAL-VL53L9](#) along with the camera flex connector, which enables MIPI-based readings and allows interfacing with [NUCLEO-N657X0-Q](#) and [STM32N6570-DK](#), Raspberry Pi, and Rockchip platforms.

We can also connect via flying wires on the header. This makes it easier to integrate the board into the development and evaluation devices, thanks to their small size.

The [STEVAL-VL53L9](#) board integrates the [VL53L9CX](#).

The [VL53L9CX](#) is a dToF 3D LiDAR all-in-one module, offering a high spatial resolution of 2.3 K zones. It features a 71° diagonal FoV, with 1° angular resolution across a 55 x 42° FoV. It also delivers accurate ranging from 5 cm to 9 m.

Product summary	
Evaluation board based on VL53L9CX Time of Flight sensor	<a href="#">STEVAL-VL53L9</a>
3D dToF LiDAR module	<a href="#">VL53L9CXV0VE/1</a>
Applications	Home, building, and city automation/Smart home/Smart glasses (AR)/Industrial/Robotics/Drones/Humanoid robots

# 1 Breakout boards

Figure 1. Connection via flying wires to NUCLEO-N657X0-Q

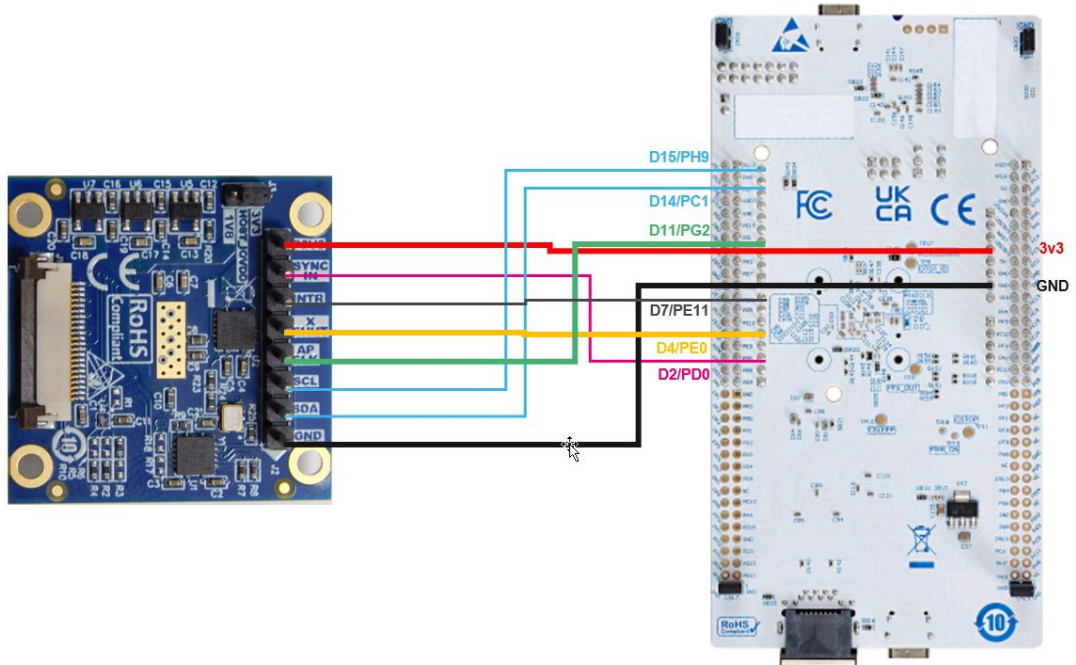

## 2 Schematic diagrams

Figure 2. STEVAL-VL53L9 circuit schematic (1 of 6)

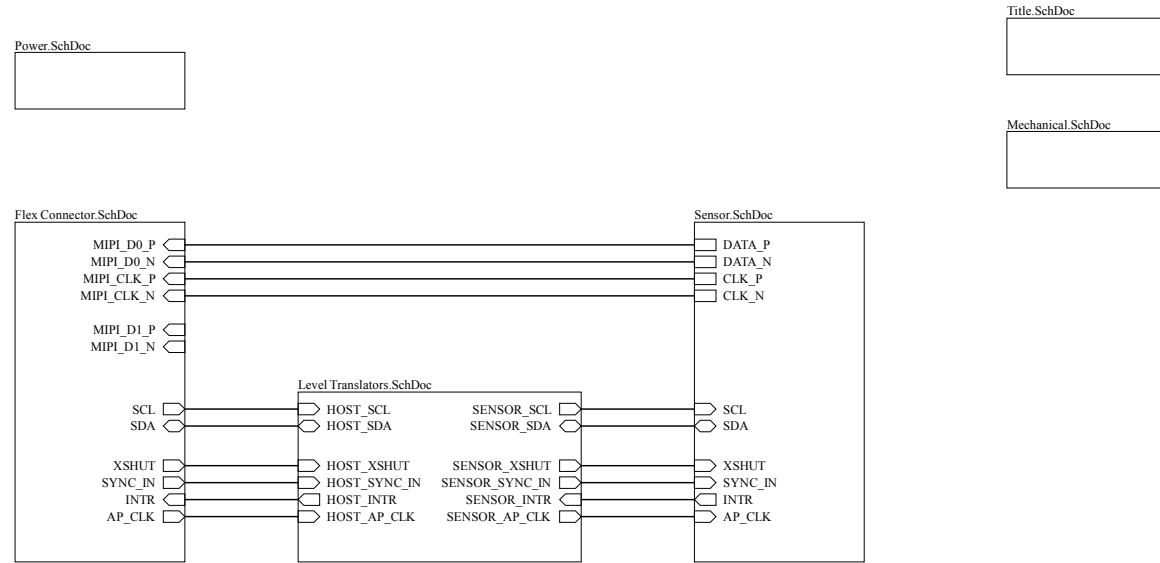
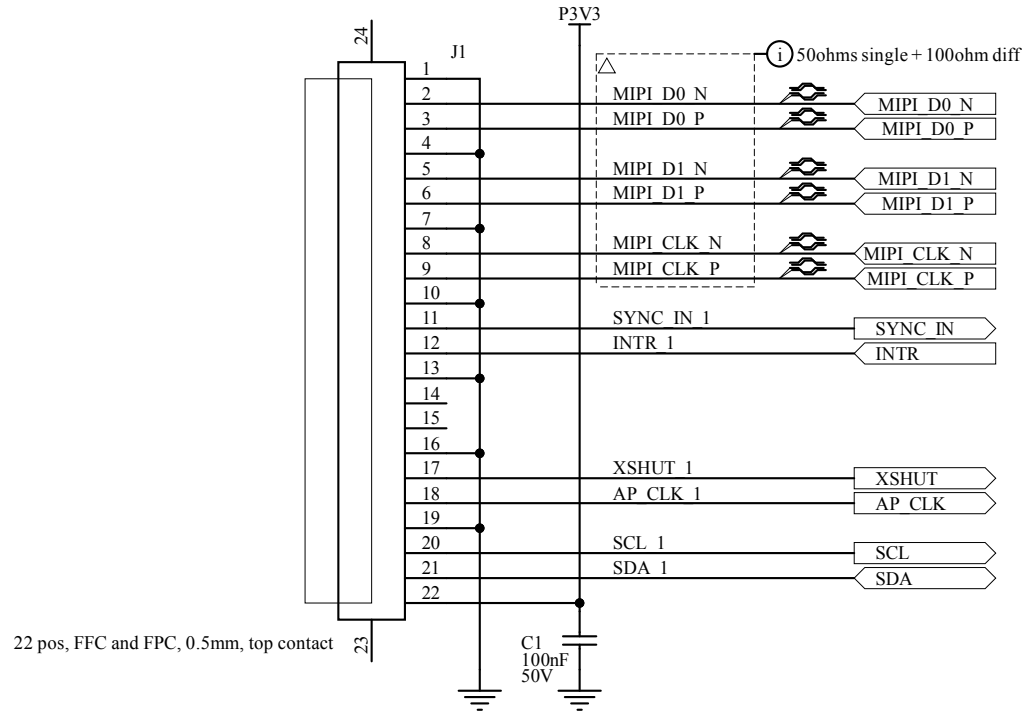
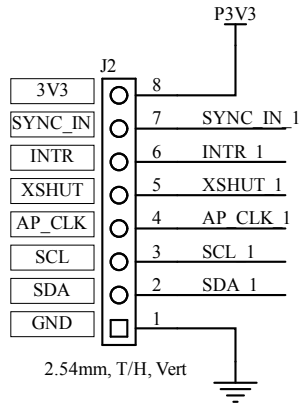

Figure 3. STEVAL-VL53L9 circuit schematic (2 of 6)

### Flex Connector

### Header



Note: Current rating per contact = 0.5 A

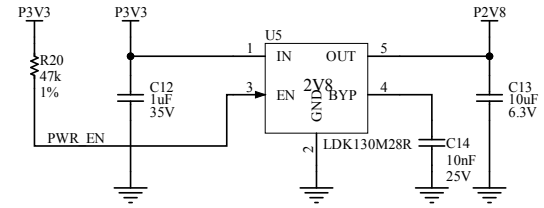

Figure 4. STEVAL-VL53L9 circuit schematic (3 of 6)

Power Supplies

2V8 Gen

3V3 supplied from flex connector.



1V8 Gen

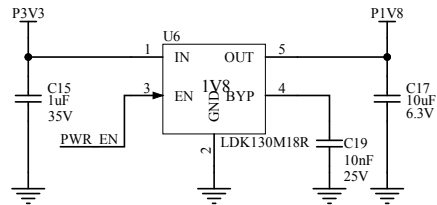

1V2 Gen

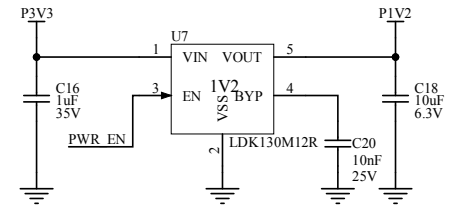
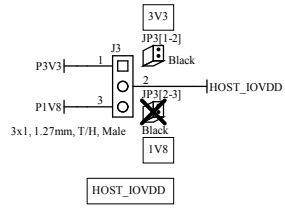
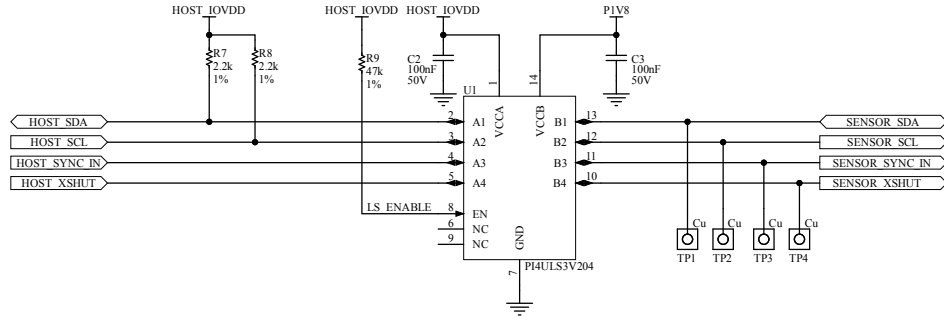

Figure 5. STEVAL-VL53L9 circuit schematic (4 of 6)

Host IO Select Header



Level Shifter  
HOST IOVDD <--> 1.8 V



Level Shifter  
HOST IOVDD <--> 1.8 V

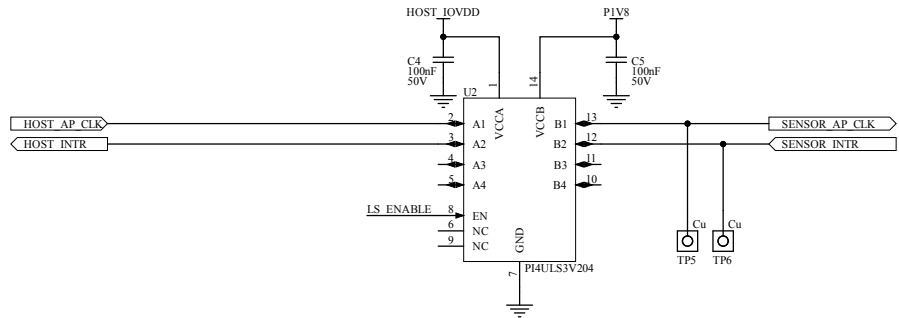

Figure 6. STEVAL-VL53L9 circuit schematic (5 of 6)

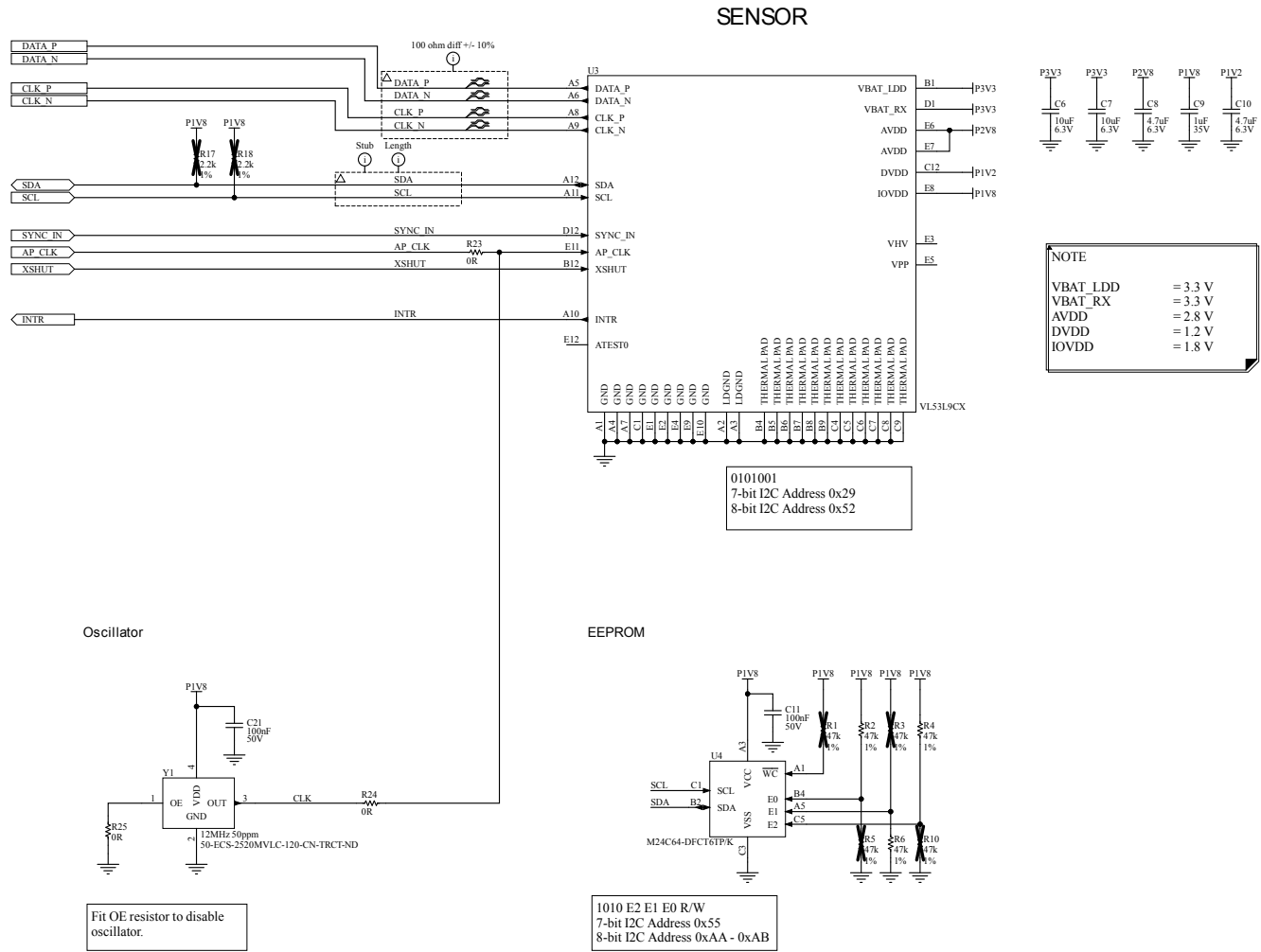
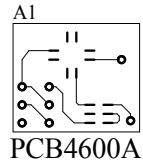

Figure 7. STEVAL-VL53L9 circuit schematic (6 of 6)

### Board Labels



MP1



### Mounting Holes

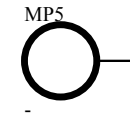
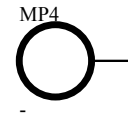
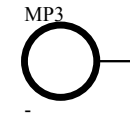
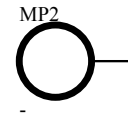

### 3 Board versions

**Table 1. STEVAL-VL53L9 versions**

Finished good	Schematic diagrams	Bill of materials	Core product
STV\$VL53L9A <sup>(1)</sup>	STV\$VL53L9A schematic diagrams	STV\$VL53L9A bill of materials	VL53L9CX

1. This code identifies the STEVAL-VL53L9 evaluation board first version.

## Revision history

**Table 2. Document revision history**

Date	Revision	Changes
30-Mar-2026	1	Initial release.
28-Apr-2026	2	Updated Features and Description.

**IMPORTANT NOTICE – READ CAREFULLY**

STMicroelectronics NV and its subsidiaries (“ST”) reserve the right to make changes, corrections, enhancements, modifications, and improvements to ST products and/or to this document at any time without notice.

In the event of any conflict between the provisions of this document and the provisions of any contractual arrangement in force between the purchasers and ST, the provisions of such contractual arrangement shall prevail.

The purchasers should obtain the latest relevant information on ST products before placing orders. ST products are sold pursuant to ST’s terms and conditions of sale in place at the time of order acknowledgment.

The purchasers are solely responsible for the choice, selection, and use of ST products and ST assumes no liability for application assistance or the design of the purchasers’ products.

No license, express or implied, to any intellectual property right is granted by ST herein.

Resale of ST products with provisions different from the information set forth herein shall void any warranty granted by ST for such product.

If the purchasers identify an ST product that meets their functional and performance requirements but that is not designated for the purchasers’ market segment, the purchasers shall contact ST for more information.

ST and the ST logo are trademarks of ST. For additional information about ST trademarks, refer to [www.st.com/trademarks](http://www.st.com/trademarks). All other product or service names are the property of their respective owners.

Information in this document supersedes and replaces information previously supplied in any prior versions of this document.

© 2026 STMicroelectronics – All rights reserved