



## STM32 audio engine – MP3 decoder library

Data brief

### Features

- MPEG-1, 2 or 2.5 formats
- Layers 1, 2 and 3
- Constant bit rate and variable bit rate
- Mono or stereo input streams
- PCM (Pulse Code Modulation) output
- Solution optimized for STM32
- MP3 decoder with built-in equalizer
- Audio utilities:
  - Channel mixer utility (for volume and mute control)
  - Standalone 5-band parametric equalizer utility
- Loudness control utility
- Object codes, accessed by the user application through an extensive API in C
- Full documentation included, demo software available
- Demo project available for IAR EWARM, Keil MDK-ARM and Raisonance RIDE

### Description

STMicroelectronics STM32 Audio Engine is a set of software libraries allowing customers to build audio applications with high-quality and professional results.

The popular MP3 format is part of the formats a professional application should support to ensure the best musical experience.

Therefore, the MP3 decoder library is a must. It removes the need for an external MP3 decoding component. Moreover, unlike many open-source solutions, it was written specifically for STM32, and is therefore highly optimized, leaving room for other application tasks to run concurrently with the audio decoding.

In addition, it comes with a set of impressive additions such as a channel mixer, a standalone 5-band parametric equalizer and loudness control to provide a complete plug-and-play solution for STM32 customers.

The MP3 decoder library is not available for all STM32 family members (see further).

# 1 Functional description

## 1.1 MP3 background

The popular MP3, short for MPEG-1/MPEG-2 Layer 3, is a format allowing to store digital audio using lossy compression algorithms. It was patented by Technicolor.

## 1.2 Royalties and part numbers

Some royalties are due to the patent owner. For the MP3 decoder, STMicroelectronics proposes to embed the royalties in the chip prices, in order to ease customers life, and to leverage royalty costs on high volumes.

In order to know the quantities of delivered ships, STMicroelectronics is therefore proposing specific part numbers. Please refer to the product datasheets for more information, or contact your local ST sales representative.

## 1.3 Operating principle

The delivered package contains four libraries, one per main feature:

- MP3 decoder
- Channel mixer
- Equalizer
- Loudness control

While the MP3 decoder is using a “Pull” mechanism, in which the decoding function calls a callback function to retrieve the data, the three other libraries use a “Push” mechanism, thus accepting one input buffer (or several) and generating an output buffer at the time of a call.

**Figure 1. MP3 decoder flow, in “Pull” mode: callback way**

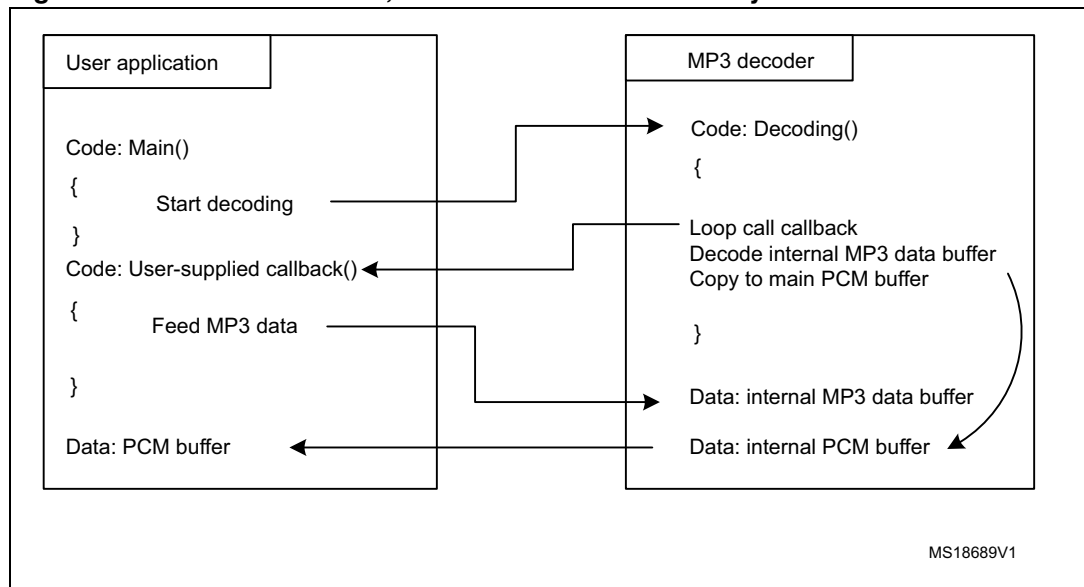

**Figure 2. “Push” mode: no callback**

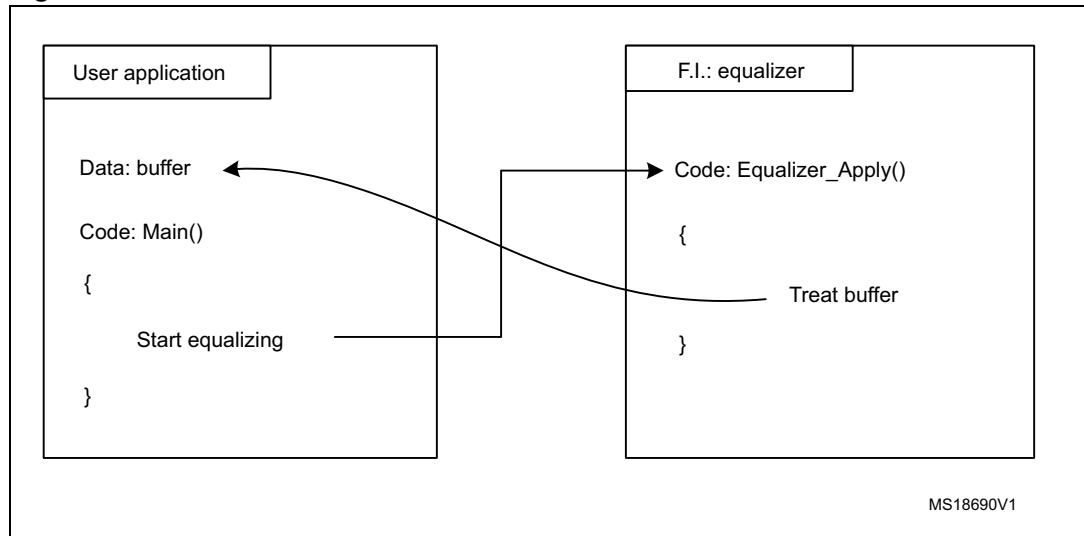

The developer is then free to use PCM buffers as needed by his application - streaming them out to I<sup>2</sup>S, for instance.

**Table 1. Performance and memory size**

STM32 audio engine	Average MIPS	Peak MIPS <sup>(1)</sup>	Flash memory size in bytes		RAM size in bytes
			Code	Constant	
MP3 decoder	20	22	15508	7108	12344
Channel mixer	2.9	2.9	584	0	16
Parametric equalizer	19	22 <sup>(2)</sup>	1560	124	300
Loudness control	5.3	5.5	1992	1256	632

1. Worst- case MIPS estimated for 320 kbps 48 KHz stereo audio, using STM32 with 0 wait-state flash access.
2. Worst-case MIPS estimated for 5-band peaking.

## 2 Ordering information

For any further information, or to order the product, please contact your nearest ST sales office.

## 3 Revision history

**Table 2. Document revision history**

Date	Revision	Changes
18-Apr-2011	1	Initial release.

**Please Read Carefully:**

Information in this document is provided solely in connection with ST products. STMicroelectronics NV and its subsidiaries ("ST") reserve the right to make changes, corrections, modifications or improvements, to this document, and the products and services described herein at any time, without notice.

All ST products are sold pursuant to ST's terms and conditions of sale.

Purchasers are solely responsible for the choice, selection and use of the ST products and services described herein, and ST assumes no liability whatsoever relating to the choice, selection or use of the ST products and services described herein.

No license, express or implied, by estoppel or otherwise, to any intellectual property rights is granted under this document. If any part of this document refers to any third party products or services it shall not be deemed a license grant by ST for the use of such third party products or services, or any intellectual property contained therein or considered as a warranty covering the use in any manner whatsoever of such third party products or services or any intellectual property contained therein.

**UNLESS OTHERWISE SET FORTH IN ST'S TERMS AND CONDITIONS OF SALE ST DISCLAIMS ANY EXPRESS OR IMPLIED WARRANTY WITH RESPECT TO THE USE AND/OR SALE OF ST PRODUCTS INCLUDING WITHOUT LIMITATION IMPLIED WARRANTIES OF MERCHANTABILITY, FITNESS FOR A PARTICULAR PURPOSE (AND THEIR EQUIVALENTS UNDER THE LAWS OF ANY JURISDICTION), OR INFRINGEMENT OF ANY PATENT, COPYRIGHT OR OTHER INTELLECTUAL PROPERTY RIGHT.**

**UNLESS EXPRESSLY APPROVED IN WRITING BY AN AUTHORIZED ST REPRESENTATIVE, ST PRODUCTS ARE NOT RECOMMENDED, AUTHORIZED OR WARRANTED FOR USE IN MILITARY, AIR CRAFT, SPACE, LIFE SAVING, OR LIFE SUSTAINING APPLICATIONS, NOR IN PRODUCTS OR SYSTEMS WHERE FAILURE OR MALFUNCTION MAY RESULT IN PERSONAL INJURY, DEATH, OR SEVERE PROPERTY OR ENVIRONMENTAL DAMAGE. ST PRODUCTS WHICH ARE NOT SPECIFIED AS "AUTOMOTIVE GRADE" MAY ONLY BE USED IN AUTOMOTIVE APPLICATIONS AT USER'S OWN RISK.**

Resale of ST products with provisions different from the statements and/or technical features set forth in this document shall immediately void any warranty granted by ST for the ST product or service described herein and shall not create or extend in any manner whatsoever, any liability of ST.

ST and the ST logo are trademarks or registered trademarks of ST in various countries.

Information in this document supersedes and replaces all information previously supplied.

The ST logo is a registered trademark of STMicroelectronics. All other names are the property of their respective owners.

© 2011 STMicroelectronics - All rights reserved

STMicroelectronics group of companies

Australia - Belgium - Brazil - Canada - China - Czech Republic - Finland - France - Germany - Hong Kong - India - Israel - Italy - Japan - Malaysia - Malta - Morocco - Philippines - Singapore - Spain - Sweden - Switzerland - United Kingdom - United States of America

[www.st.com](http://www.st.com)

