

Trench gate field-stop, 650 V, 75 A, high-speed HB2 series IGBT in a TO-247 long leads package

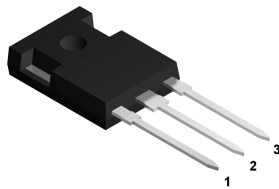

TO-247 long leads

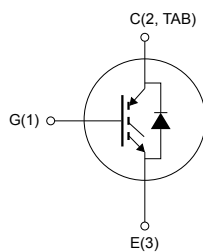

NG1E3C2T



Features

- Maximum junction temperature: $T_J = 175\text{ °C}$
- Low $V_{CE(sat)} = 1.55\text{ V (typ.) @ } I_C = 75\text{ A}$
- Co-packed with high ruggedness rectifier diode
- Minimized tail current
- Tight parameter distribution
- Low thermal resistance
- Positive $V_{CE(sat)}$ temperature coefficient

Applications

- Welding
- PFC converters - single phase input
- Solar inverters (string and central)
- Uninterruptable power supplies (UPS)
- EV charging - DC fast charging stations

Description

The newest IGBT 650 V HB2 series represents an evolution of the advanced proprietary trench gate field-stop structure. The performances are optimized both in conduction and switching energies for hard switching application. In this configuration, it has been co-packed with a high ruggedness rectifier diode.

Product status link

[GWA75H65DRFB2](#)

Product summary

Order code	GWA75H65DRFB2
Marking	G75H65DRFB2
Package	TO-247 long leads
Packing	Tube

1 Electrical ratings

Table 1. Absolute maximum ratings

Symbol	Parameter	Value	Unit
V_{CES}	Collector-emitter voltage ($V_{GE} = 0$ V)	650	V
I_C	Continuous collector current at $T_C = 25$ °C	123	A
	Continuous collector current at $T_C = 100$ °C	75	
$I_{CP}^{(1)}$	Pulsed collector current ($t_p \leq 1$ ms, $T_J < 175$ °C)	240	A
V_{GE}	Gate-emitter voltage	± 20	V
	Transient gate-emitter voltage ($t_p \leq 10$ μ s, $D < 0.01$)	± 30	
I_F	Continuous forward current at $T_C = 25$ °C	195	A
	Continuous forward current at $T_C = 100$ °C	75	
$I_{FP}^{(1)}$	Pulsed forward current ($t_p \leq 1$ ms, $T_J < 175$ °C)	240	A
P_{TOT}	Total power dissipation at $T_C = 25$ °C	395	W
T_{STG}	Storage temperature range	-55 to 150	°C
T_J	Operating junction temperature range	-55 to 175	°C

1. Specified by design, not tested in production.

Table 2. Thermal data

Symbol	Parameter	Value	Unit
R_{thJC}	Thermal resistance, junction-to-case, IGBT	0.38	°C/W
	Thermal resistance, junction-to-case, diode	0.38	
R_{thJA}	Thermal resistance, junction-to-ambient	50	°C/W

2 Electrical characteristics

$T_C = 25\text{ °C}$ unless otherwise specified

Table 3. Static characteristics

Symbol	Parameter	Test conditions	Min.	Typ.	Max.	Unit
$V_{(BR)CES}$	Collector-emitter breakdown voltage	$V_{GE} = 0\text{ V}$, $I_C = 1\text{ mA}$	650			V
$V_{CE(sat)}$	Collector-emitter saturation voltage	$V_{GE} = 15\text{ V}$, $I_C = 75\text{ A}$		1.6	2	V
		$V_{GE} = 15\text{ V}$, $I_C = 75\text{ A}$, $T_J = 125\text{ °C}$		1.8		
		$V_{GE} = 15\text{ V}$, $I_C = 75\text{ A}$, $T_J = 175\text{ °C}$		1.9		
V_F	Forward on-voltage	$I_F = 75\text{ A}$		1.15	1.5	V
		$I_F = 75\text{ A}$, $T_J = 125\text{ °C}$		1.1		
		$I_F = 75\text{ A}$, $T_J = 175\text{ °C}$		1.07		
$V_{GE(th)}$	Gate threshold voltage	$V_{CE} = V_{GE}$, $I_C = 1\text{ mA}$	5	6	7	V
I_{CES}	Collector cut-off current	$V_{GE} = 0\text{ V}$, $V_{CE} = 650\text{ V}$			25	μA
I_{GES}	Gate-emitter leakage current	$V_{CE} = 0\text{ V}$, $V_{GE} = \pm 20\text{ V}$			± 250	nA

Table 4. Dynamic characteristics

Symbol	Parameter	Test conditions	Min.	Typ.	Max.	Unit
C_{ies}	Input capacitance	$V_{CE} = 25\text{ V}$, $f = 1\text{ MHz}$, $V_{GE} = 0\text{ V}$	-	4400	-	pF
C_{oes}	Output capacitance		-	209	-	pF
C_{res}	Reverse transfer capacitance		-	120	-	pF
Q_g	Total gate charge	$V_{CC} = 520\text{ V}$, $I_C = 75\text{ A}$, $V_{GE} = 0\text{ to }15\text{ V}$ (see Figure 28. Gate charge test circuit)	-	253	-	nC
Q_{ge}	Gate-emitter charge		-	33	-	nC
Q_{gc}	Gate-collector charge		-	126	-	nC

Table 5. Switching characteristics (inductive load)

Symbol	Parameter	Test conditions	Min.	Typ.	Max.	Unit
$t_{d(on)}$	Turn-on delay time	$V_{CC} = 400\text{ V}$, $I_C = 75\text{ A}$, $V_{GE} = 15\text{ V}$, $R_G = 2.2\ \Omega$ (see Figure 27. Test circuit for inductive load switching)	-	28	-	ns
t_r	Current rise time		-	46.7	-	ns
$E_{on}^{(1)}$	Turn-on switching energy		-	12.9	-	mJ
$t_{d(off)}$	Turn-off delay time		-	103	-	ns
t_f	Current fall time		-	29	-	ns
$E_{off}^{(2)}$	Turn-off switching energy		-	0.9	-	mJ
$t_{d(on)}$	Turn-on delay time	$V_{CC} = 400\text{ V}$, $I_C = 75\text{ A}$, $V_{GE} = 15\text{ V}$, $R_G = 2.2\ \Omega$, $T_J = 175\text{ }^\circ\text{C}$ (see Figure 27. Test circuit for inductive load switching)	-	28	-	ns
t_r	Current rise time		-	44	-	ns
$E_{on}^{(1)}$	Turn-on switching energy		-	14.2	-	mJ
$t_{d(off)}$	Turn-off delay time		-	122	-	ns
t_f	Current fall time		-	70	-	ns
$E_{off}^{(2)}$	Turn-off switching energy		-	14.7	-	mJ

1. Including the reverse recovery of the diode.
2. Including the tail of the collector current.

Table 6. Diode switching characteristics (inductive load)

Symbol	Parameter	Test conditions	Min.	Typ.	Max.	Unit
t_{rr}	Reverse recovery time	$I_F = 75\text{ A}$, $V_R = 400\text{ V}$, $V_{GE} = 15\text{ V}$, $di/dt = 400\text{ A}/\mu\text{s}$ (see Figure 30. Diode reverse recovery waveform)	-	710	-	ns
Q_{rr}	Reverse recovery charge		-	44.6	-	μC
I_{rrm}	Reverse recovery current		-	120	-	A
di_{rr}/dt	Peak rate of fall of reverse recovery current during t_b		-	290	-	$\text{A}/\mu\text{s}$
E_{rr}	Reverse recovery energy		-	7.45	-	mJ
t_{rr}	Reverse recovery time	$I_F = 75\text{ A}$, $V_R = 400\text{ V}$, $V_{GE} = 15\text{ V}$, $di/dt = 400\text{ A}/\mu\text{s}$, $T_J = 175\text{ }^\circ\text{C}$ (see Figure 30. Diode reverse recovery waveform)	-	870	-	ns
Q_{rr}	Reverse recovery charge		-	54.5	-	μC
I_{rrm}	Reverse recovery current		-	122	-	A
di_{rr}/dt	Peak rate of fall of reverse recovery current during t_b		-	223	-	$\text{A}/\mu\text{s}$
E_{rr}	Reverse recovery energy		-	9.2	-	mJ

2.1 Electrical characteristics (curves)

Figure 1. Total power dissipation vs temperature

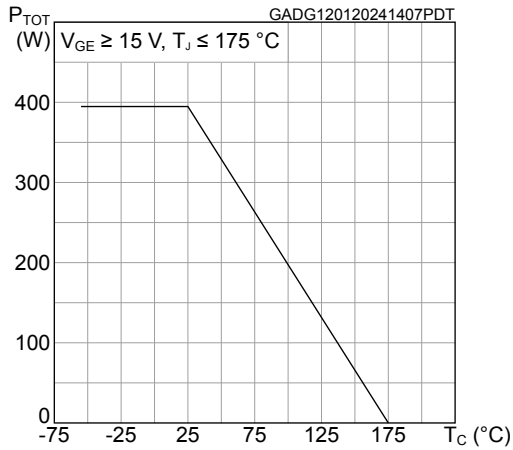

Figure 2. Collector current vs temperature

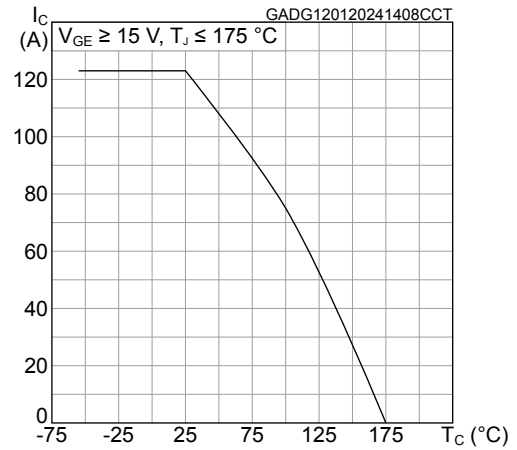

Figure 3. Typical output characteristics ($T_J = 25\text{ °C}$)

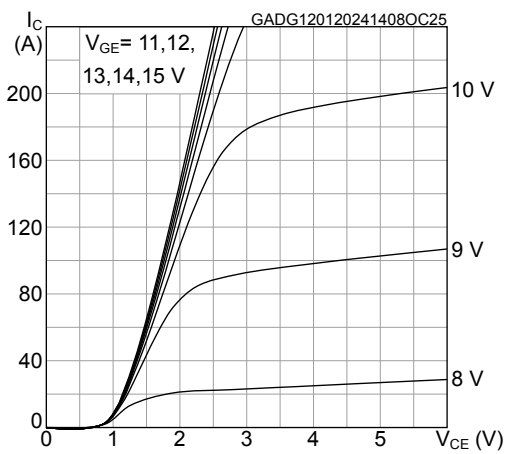

Figure 4. Typical output characteristics ($T_J = 175\text{ °C}$)

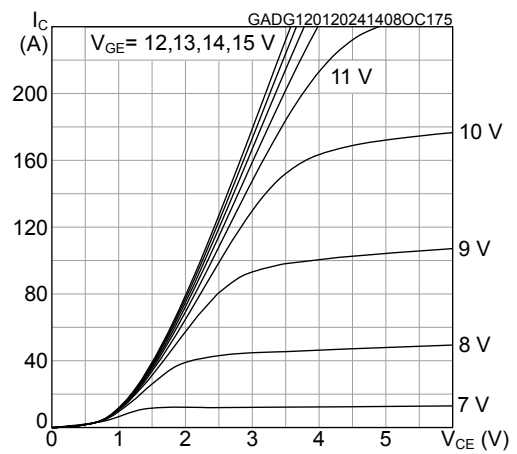

Figure 5. Typical transfer characteristics

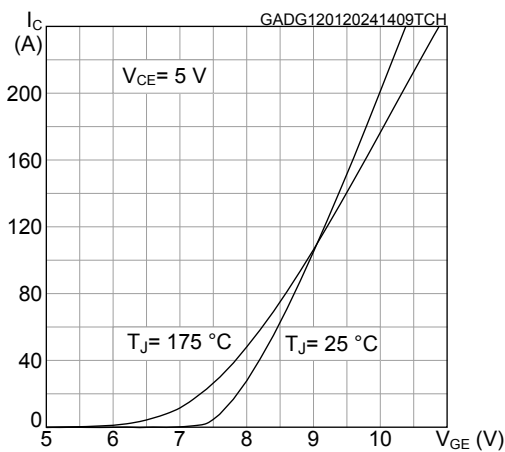

Figure 6. Typical $V_{CE(sat)}$ vs temperature

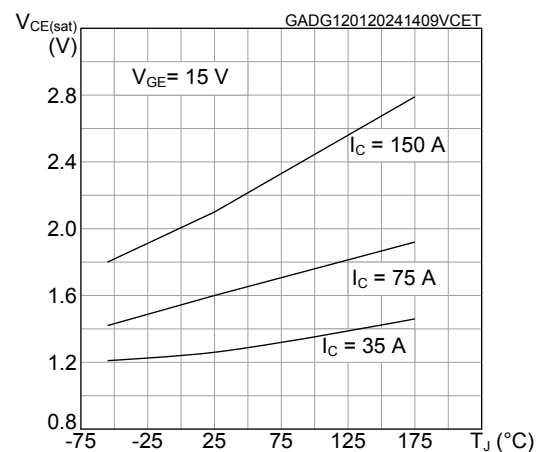

Figure 7. Typical $V_{CE(sat)}$ vs collector current

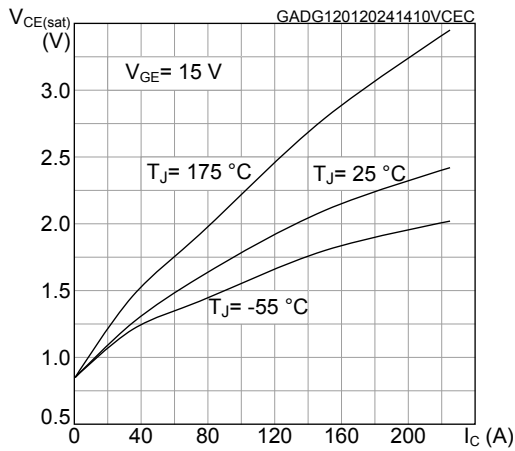

Figure 8. Forward bias safe operating area

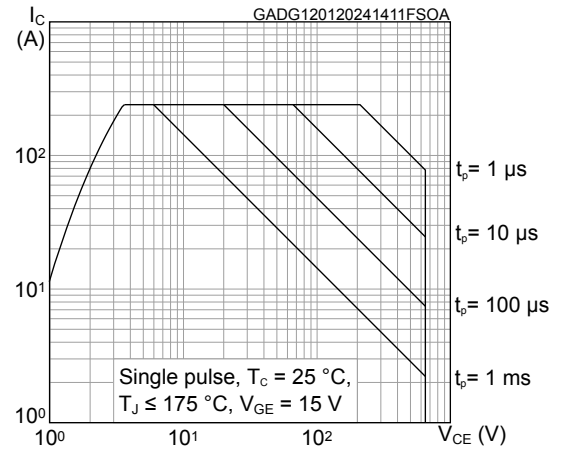

Figure 9. Diode typical V_F vs forward current

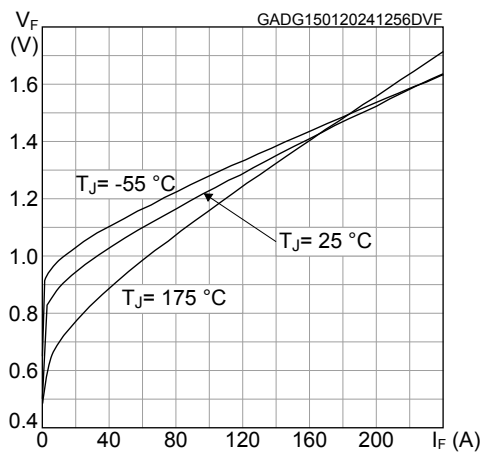

Figure 10. Typical I_C vs switching frequency

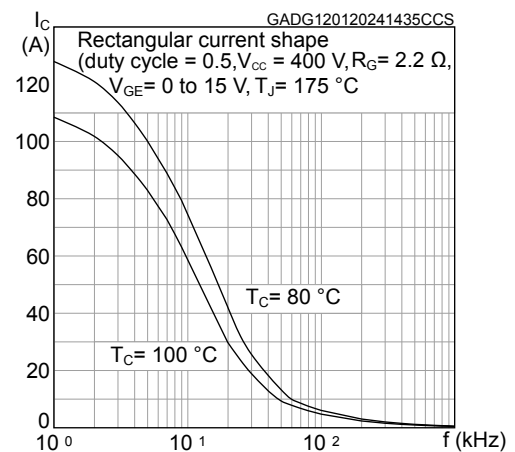

Figure 11. Normalized $V_{GE(th)}$ vs junction temperature

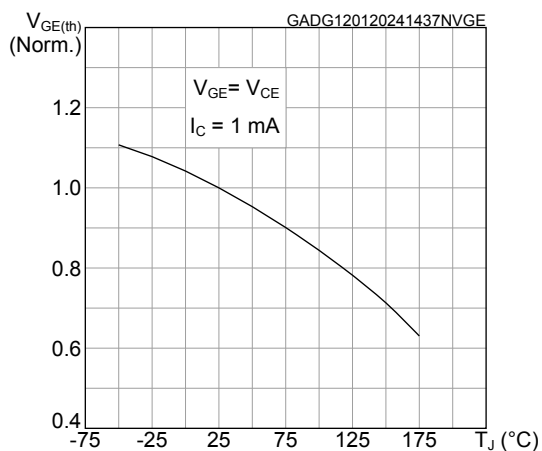

Figure 12. Normalized $V_{(BR)CES}$ vs junction temperature

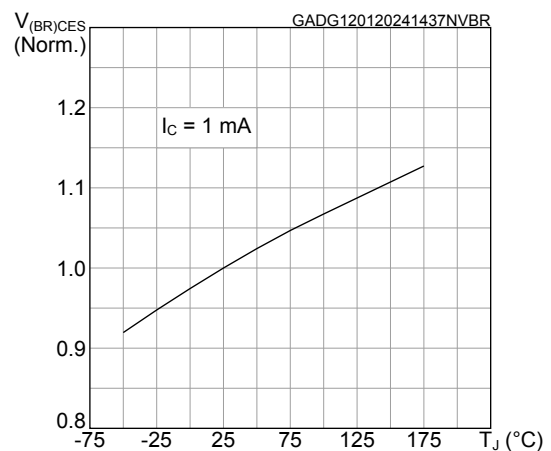

Figure 13. Typical capacitance characteristics

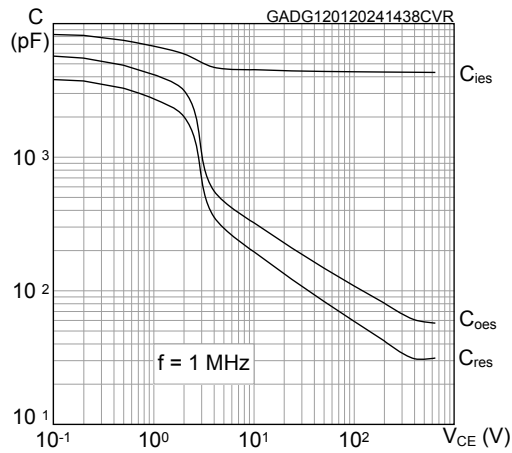

Figure 14. Typical gate charge characteristics

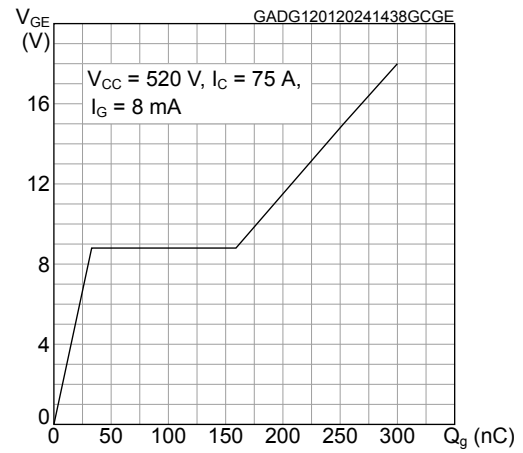

Figure 15. Typical switching energy vs collector current

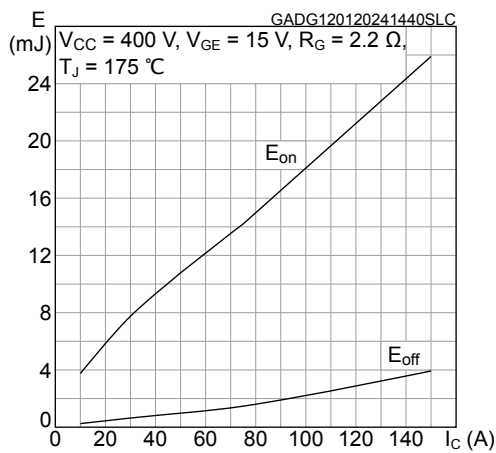

Figure 16. Typical switching energy vs temperature

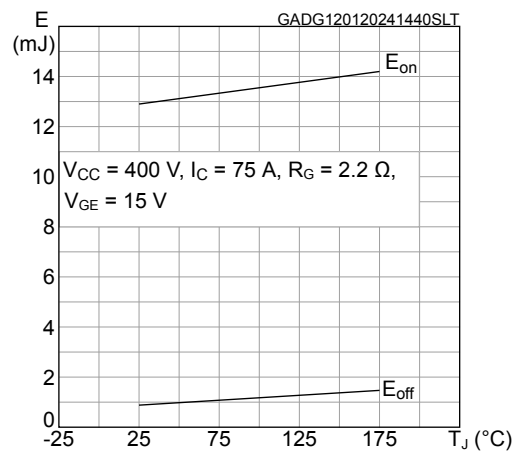

Figure 17. Typical switching energy vs VCE

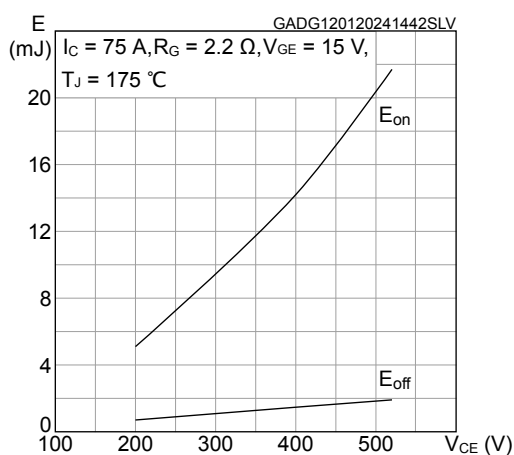

Figure 18. Typical switching energy vs gate resistance

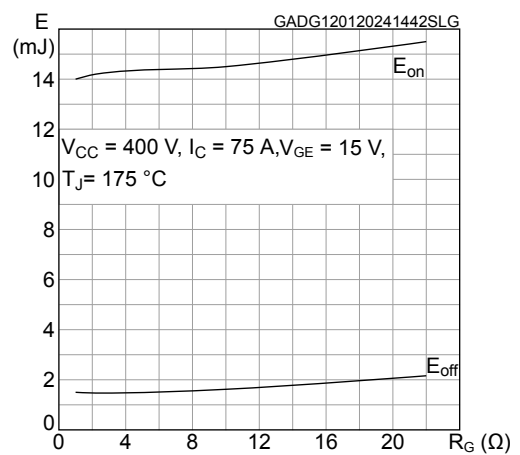

Figure 19. Typical switching times vs collector current

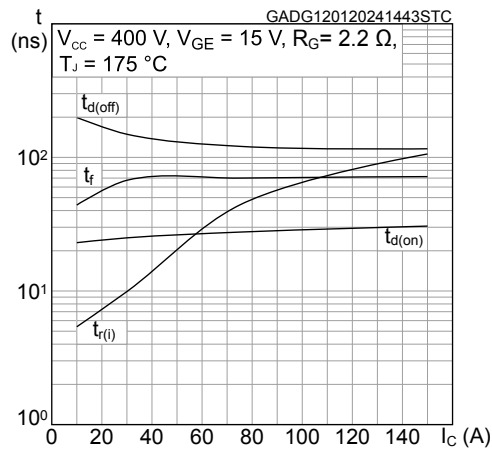

Figure 20. Typical switching times vs gate resistance

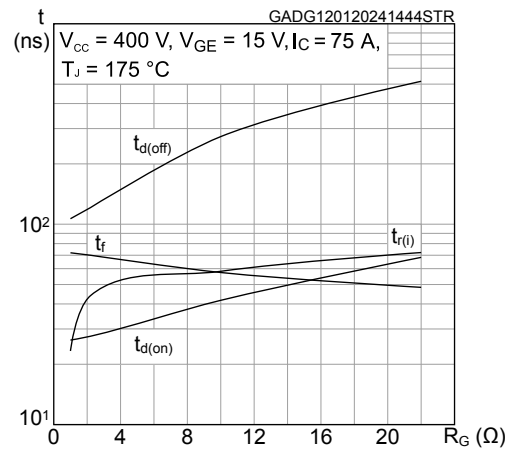

Figure 21. Typical reverse recovery current vs diode current slope

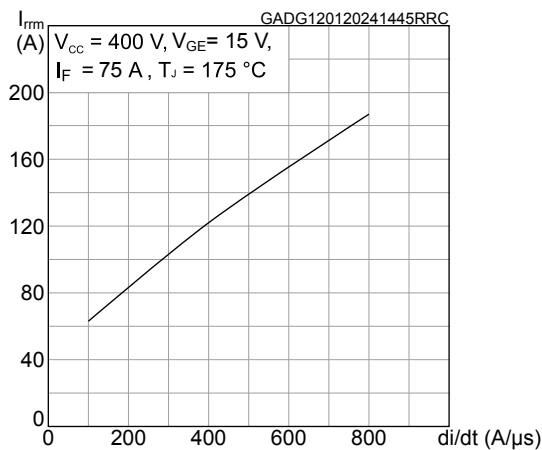

Figure 22. Typical reverse recovery time vs diode current slope

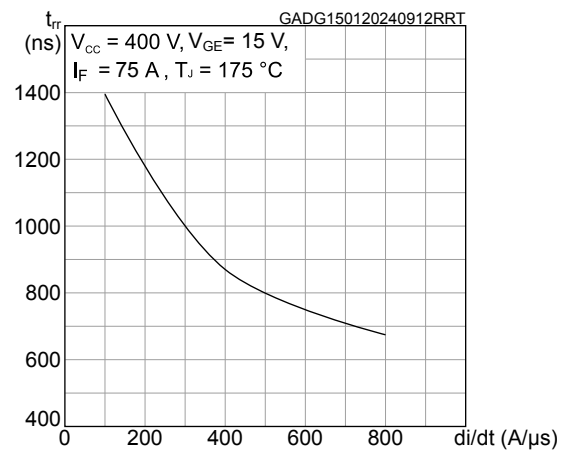

Figure 23. Typical reverse recovery charge vs diode current slope

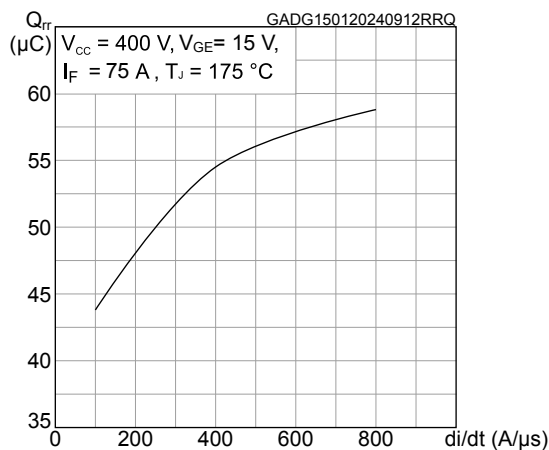

Figure 24. Typical reverse recovery energy vs diode current slope

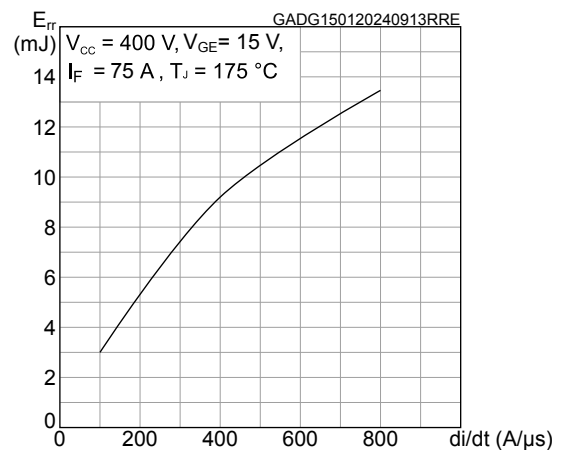

Figure 25. IGBT maximum transient thermal impedance

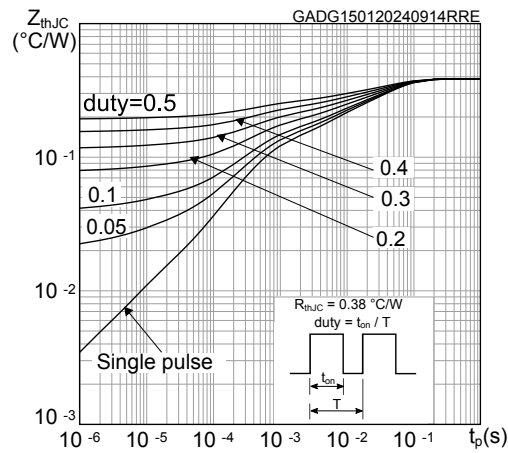
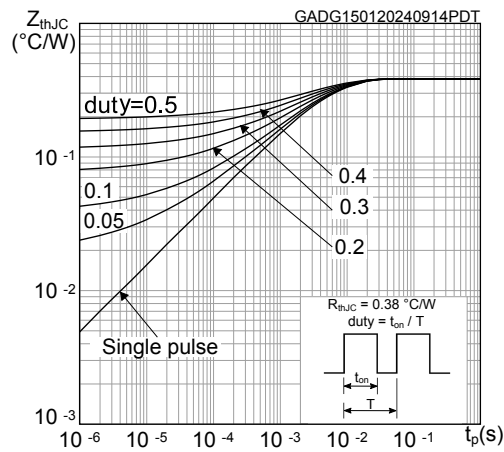
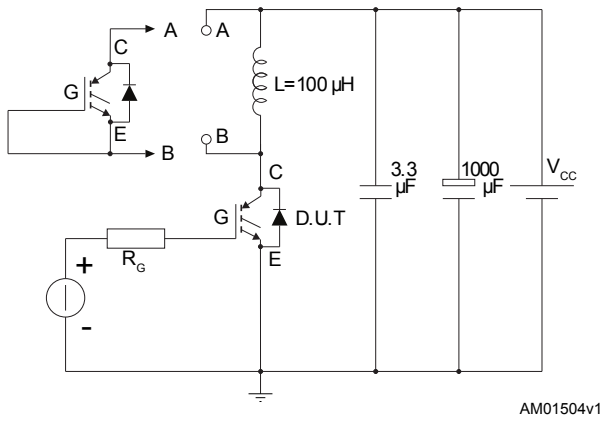
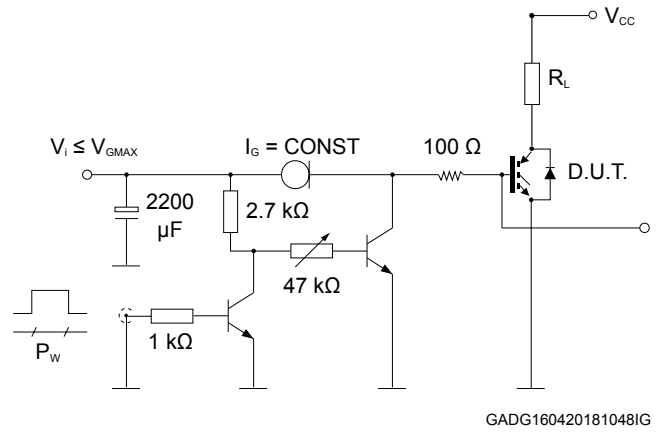
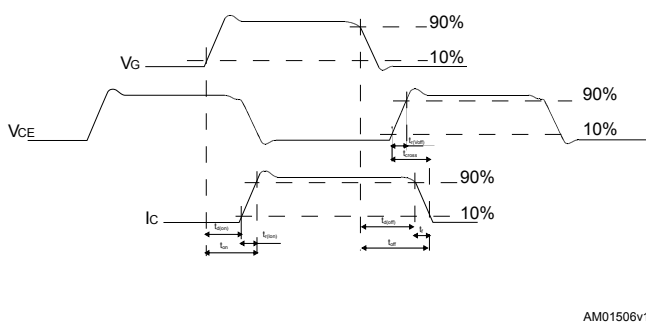
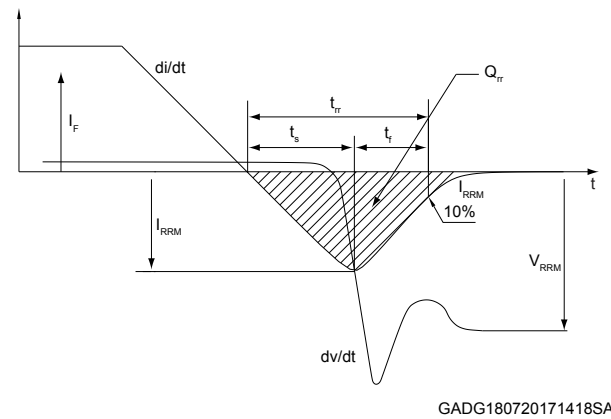

Figure 26. Diode maximum transient thermal impedance



3 Test circuits

Figure 27. Test circuit for inductive load switching

Figure 28. Gate charge test circuit

Figure 29. Switching waveform

Figure 30. Diode reverse recovery waveform

4 Package information

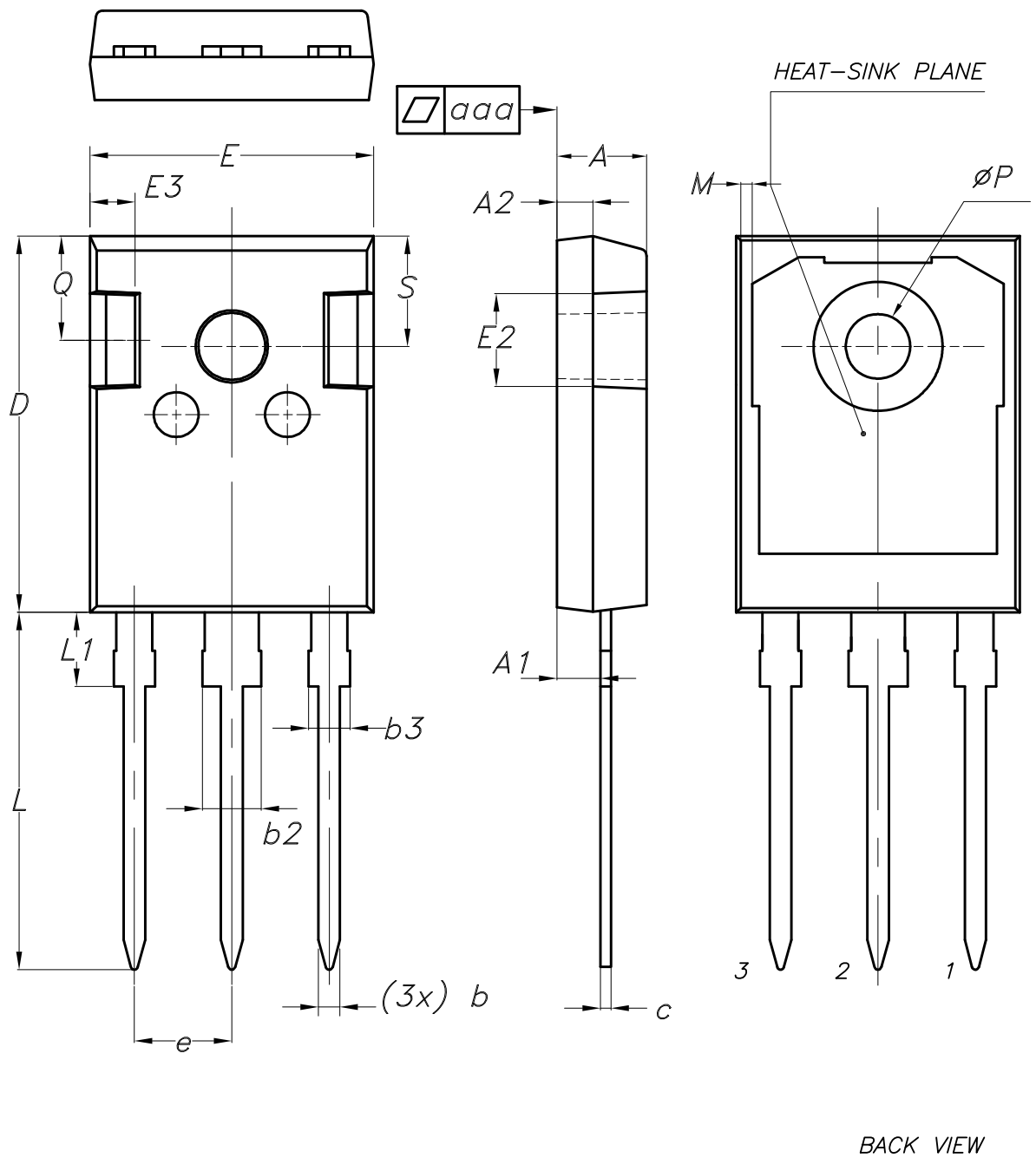
In order to meet environmental requirements, ST offers these devices in different grades of **ECOPACK** packages, depending on their level of environmental compliance. ECOPACK specifications, grade definitions and product status are available at: www.st.com. ECOPACK is an ST trademark.

4.1 TO-247 long leads package information

Figure 31. TO-247 long leads package outline



8463846_5

Table 7. TO-247 long leads package mechanical data

Dim.	mm		
	Min.	Typ.	Max.
A	4.90	5.00	5.10
A1	2.31	2.41	2.51
A2	1.90	2.00	2.10
b	1.16		1.26
b2			3.25
b3			2.25
c	0.59		0.66
D	20.90	21.00	21.10
E	15.70	15.80	15.90
E2	4.90	5.00	5.10
E3	2.40	2.50	2.60
e	5.34	5.44	5.54
L	19.80	19.92	20.10
L1			4.30
M	0.35		0.95
P	3.50	3.60	3.70
Q	5.60		6.00
S	6.05	6.15	6.25
aaa		0.04	0.10

Revision history

Table 8. Document revision history

Date	Revision	Changes
19-Feb-2024	1	First release.

Contents

1	Electrical ratings	2
2	Electrical characteristics	3
2.1	Electrical characteristics (curves)	5
3	Test circuits	10
4	Package information	11
4.1	TO-247 long leads package information	11
	Revision history	13

IMPORTANT NOTICE – READ CAREFULLY

STMicroelectronics NV and its subsidiaries (“ST”) reserve the right to make changes, corrections, enhancements, modifications, and improvements to ST products and/or to this document at any time without notice. Purchasers should obtain the latest relevant information on ST products before placing orders. ST products are sold pursuant to ST’s terms and conditions of sale in place at the time of order acknowledgment.

Purchasers are solely responsible for the choice, selection, and use of ST products and ST assumes no liability for application assistance or the design of purchasers’ products.

No license, express or implied, to any intellectual property right is granted by ST herein.

Resale of ST products with provisions different from the information set forth herein shall void any warranty granted by ST for such product.

ST and the ST logo are trademarks of ST. For additional information about ST trademarks, refer to www.st.com/trademarks. All other product or service names are the property of their respective owners.

Information in this document supersedes and replaces information previously supplied in any prior versions of this document.

© 2024 STMicroelectronics – All rights reserved