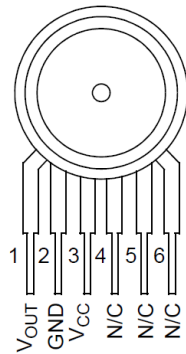
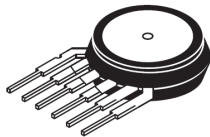

Integrated silicon pressure sensor on-chip signal conditioned, temperature compensated and calibrated

Top view

Pinout

**Unibody package
Case 867**

Features

- Temperature Compensated Over 0 °C to 85 °C
- Ideally Suited for Microprocessor or Microcontroller-Based Systems
- Patented Silicon Shear Stress Strain Gauge
- Durable Epoxy Unibody Element

Description

The MPX5999D piezoresistive transducer is a state-of-the-art pressure sensor designed for a wide range of applications, but particularly for those employing a microcontroller or microprocessor with A/D inputs. This patented, single element transducer combines advanced micromachining techniques, thin-film metallization and bipolar semiconductor processing to provide an accurate, high level analog output signal that is proportional to applied pressure.

1 Ordering information

Table 1. Ordering Information

Device Name	Case No.	# of Ports			Pressure Type			Device Marking
		None	Single	Dual	Gauge	Differential	Absolute	
Unibody Package								
MPX5999D	867	•				•		MPX5999D

2 Operating Characteristics

Table 2. Table 1. Operating Characteristics ($V_S = 5.0$ Vdc, $T_A = 25^\circ\text{C}$ unless otherwise noted, $P1 > P2$. Decoupling circuit shown in Figure 4 required to meet electrical specifications.)

Characteristic		Symbol	Min	Typ	Max	Unit
Pressure Range ⁽¹⁾		P_{OP}	0	—	1000	kPa
Supply Voltage ⁽²⁾		V_S	4.75	5.0	5.25	Vdc
Supply Current		I_O	—	7.0	10	mAdc
Zero Pressure Offset ⁽³⁾	(0 to 85 °C)	V_{off}	0.088	0.2	0.313	Vdc
Full Scale Output ⁽⁴⁾	(0 to 85 °C)	V_{FSO}	4.587	4.7	4.813	Vdc
Full Scale Span ⁽⁵⁾	(0 to 85 °C)	V_{FSS}	—	4.5	—	Vdc
Sensitivity		V/P	—	4.5	—	mV/kPa
Accuracy ⁽⁶⁾	(0 to 85 °C)	—	—	—	±2.5	% V_{FSS}
Response Time ⁽⁷⁾		t_R	—	1.0	—	ms
Output Source Current at Full Scale Output		I_{O+}	—	0.1	—	mAdc
Warm-Up Time ⁽⁸⁾		—	—	20	—	ms

1. 1.0 kPa (kiloPascal) equals 0.145 psi.

2. Device is ratiometric within this specified excitation range.

3. Offset (V_{off}) is defined as the output voltage at the minimum rated pressure.

4. Full Scale Output (V_{FSO}) is defined as the output voltage at the maximum or full rated pressure.

5. Full Scale Span (V_{FSS}) is defined as the algebraic difference between the output voltage at full rated pressure and the output voltage at the minimum rated pressure.

6. Accuracy (error budget) consists of the following:

Linearity: Output deviation from a straight line relationship with pressure over the specified pressure range.

Temperature Hysteresis: Output deviation at any temperature within the operating temperature range, after the temperature is cycled to and from the minimum or maximum operating temperature points, with zero differential pressure applied.

Pressure Hysteresis: Output deviation at any pressure within the specified range, when this pressure is cycled to and from the minimum or maximum rated pressure, at 25°C.

TcSpan: Output deviation over the temperature range of 0° to 85°C, relative to 25°C.

TcOffset: Output deviation with minimum rated pressure applied, over the temperature range of 0° to 85°C, relative to 25°C. Variation from Nominal: The variation from nominal values, for Offset or Full Scale Span, as a percent of V_{FSS} , at 25°C.

7. Response Time is defined as the time for the incremental change in the output to go from 10% to 90% of its final value when subjected to a specified step change in pressure.

8. Warm-up Time is defined as the time required for the device to meet the specified output voltage after the pressure has been stabilized.

3 Maximum ratings

Table 3. Table 2. Maximum Ratings⁽¹⁾

Rating	Symbol	Value	Unit
Maximum Pressure ⁽²⁾ ($P2 \leq 1$ Atmosphere)	P1max	4000	kPa
Storage Temperature	Tstg	-40 to +125	°C
Operating Temperature	TA	-40 to +125	°C

1. Extended exposure at the specified limits may cause permanent damage or degradation to the device.

2. This sensor is designed for applications where P1 is always greater than, or equal to P2. P2 maximum is 500 kPa.

Figure 1 shows a block diagram of the internal circuitry integrated on the stand-alone sensing chip.

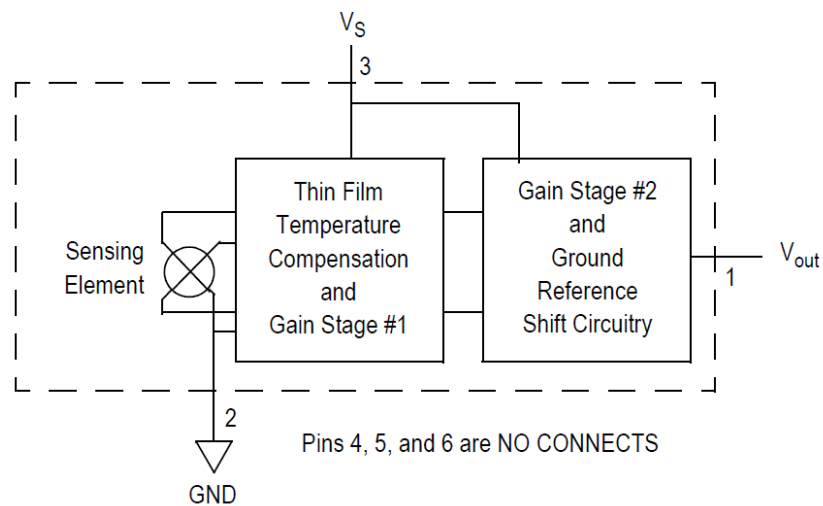
Figure 1. Figure 1. Fully Integrated Pressure Sensor Schematic

4 On-chip temperature compensation and calibration

Figure 2 shows the sensor output signal relative to pressure input. Typical, minimum, and maximum output curves are shown for operation over a temperature range of 0 °C to 85 °C using the decoupling circuit shown in Figure 4. The output will saturate outside of the specified pressure range.

The performance over temperature is achieved by integrating the shear-stress strain gauge, temperature compensation, calibration and signal conditioning circuitry onto a single monolithic chip.

Figure 3 illustrates the differential or gauge configuration in the basic chip carrier (Case 867). A fluorosilicone gel isolates the die surface and wire bonds from harsh environments, while allowing the pressure signal to be transmitted to the silicon diaphragm.

The MPX5999D pressure sensor operating characteristics, and internal reliability and qualification tests are based on use of dry air as the pressure media. Media other than dry air may have adverse effects on sensor performance and long-term reliability. Contact the factory for information regarding media compatibility in your application.

Figure 4 shows the recommended decoupling circuit for interfacing the output of the integrated sensor to the A/D input of a microprocessor or microcontroller. Proper decoupling of the power supply is recommended.

Figure 2. Output vs. Pressure Differential

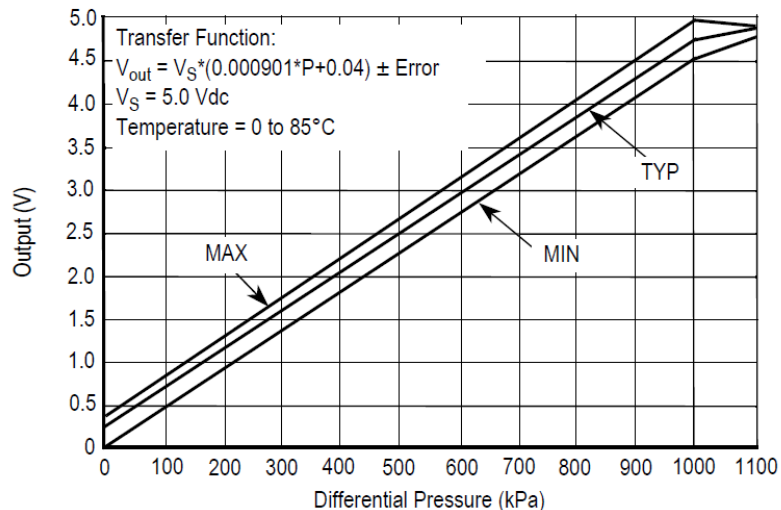

Figure 3. Cross-Sectional Diagrams (not to scale)

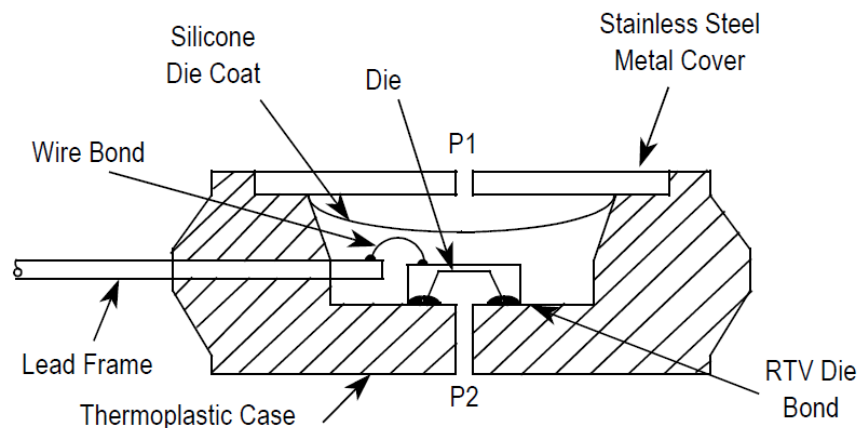
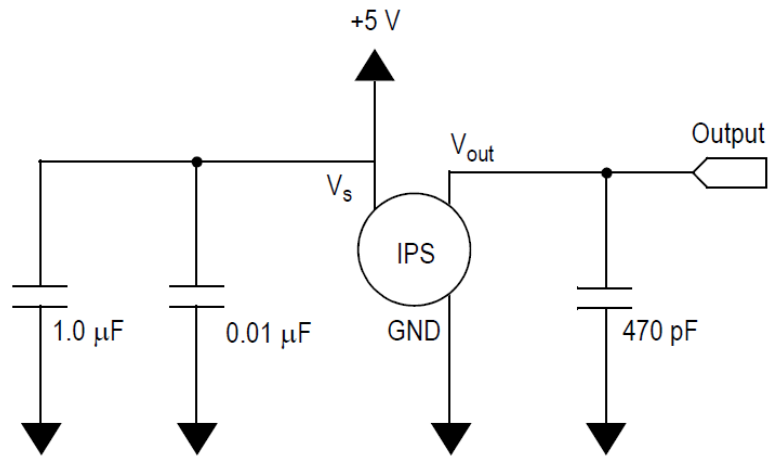

Figure 4. Recommended Power Supply Decoupling and Output Filtering (For additional output filtering, please refer to Application Note AN1646)



5 Pressure (p1)/vacuum (p2) side identification table

Freescale designates the two sides of the pressure sensor as the Pressure (P1) side and the Vacuum (P2) side. The Pressure (P1) side is the side containing fluorosilicone gel which protects the die from harsh media. The Freescale MPX pressure sensor is designed to operate with positive differential pressure applied, $P1 > P2$. The Pressure (P1) side may be identified by using the following table.

Part Number	Case Type	Pressure (P1) Side Identifier
MPX5999D	867	Stainless Steel Cap

6 Package Dimensions

Figure 5. BASIC ELEMENT

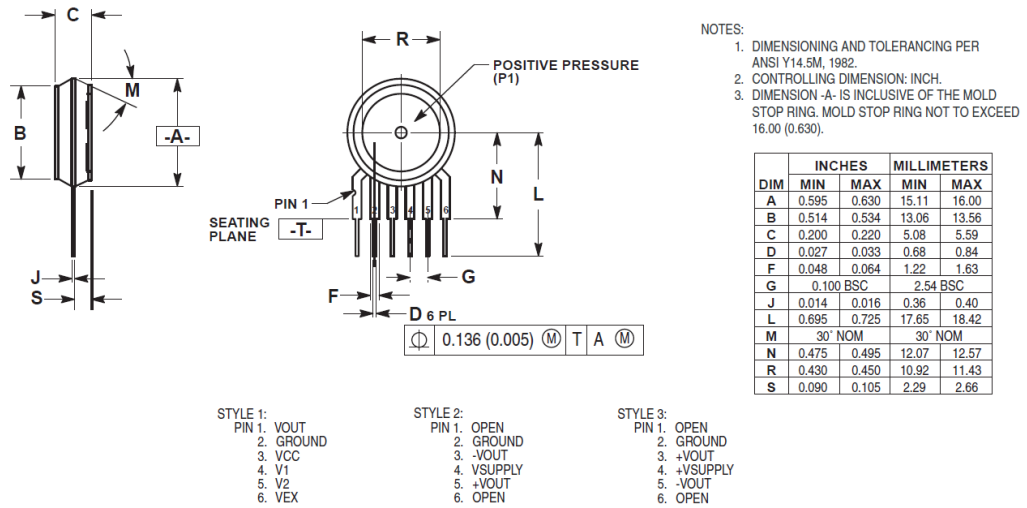

NOTE

Style 1, Style 2, and Style 3 pinouts listed in the figure above do not apply to the MPXV5999D. For the correct pinout, see the pin connection diagram located on [Page 1](#).

Revision history

Table 4. Document revision history

Date	Revision	Changes
20-May-2026	1	Initial release from ST, rebranded NXP document

Contents

1	Ordering information	2
2	Operating Characteristics	3
3	Maximum ratings	4
4	On-chip temperature compensation and calibration	5
5	Pressure (p1)/vacuum (p2) side identification table	7
6	Package Dimensions	8
	Revision history	9

IMPORTANT NOTICE – READ CAREFULLY

STMicroelectronics NV and its subsidiaries (“ST”) reserve the right to make changes, corrections, enhancements, modifications, and improvements to ST products and/or to this document at any time without notice.

In the event of any conflict between the provisions of this document and the provisions of any contractual arrangement in force between the purchasers and ST, the provisions of such contractual arrangement shall prevail.

The purchasers should obtain the latest relevant information on ST products before placing orders. ST products are sold pursuant to ST’s terms and conditions of sale in place at the time of order acknowledgment.

The purchasers are solely responsible for the choice, selection, and use of ST products and ST assumes no liability for application assistance or the design of the purchasers’ products.

No license, express or implied, to any intellectual property right is granted by ST herein.

Resale of ST products with provisions different from the information set forth herein shall void any warranty granted by ST for such product.

If the purchasers identify an ST product that meets their functional and performance requirements but that is not designated for the purchasers’ market segment, the purchasers shall contact ST for more information.

ST and the ST logo are trademarks of ST. For additional information about ST trademarks, refer to www.st.com/trademarks. All other product or service names are the property of their respective owners.

Information in this document supersedes and replaces information previously supplied in any prior versions of this document.

© 2026 STMicroelectronics – All rights reserved