

High efficiency solar battery charger with embedded MPPT



Features

- 0.3 V to 5.5 V operating input voltage
- 140 mΩ internal synchronous rectifier
- 120 mΩ internal power active switch
- 100 kHz fixed PWM frequency
- Duty cycle controlled by MPPT algorithm
- Output voltage regulation, overcurrent and overtemperature protection
- Input source reverse polarity protection
- Built-in soft-start
- Up to 95% efficiency
- TSSOP8 package 3x4.4 mm

Applications

- Smart phones and GPS systems
- Wireless headsets
- Small appliances, sensors
- Portable media players
- Digital still cameras
- Toys and portable healthcare

Description

The SPV1040 device is a low power, low voltage, monolithic step-up converter with an input voltage range from 0.3 V to 5.5 V, capable of maximizing the energy generated by solar cells (or fuel cells), where low input voltage handling capability is extremely important. Thanks to the embedded MPPT algorithm, even under varying environmental conditions (such as irradiation, dirt, temperature) the SPV1040 offers maximum efficiency in terms of power harvested from the cells and transferred to the output. The device employs a voltage regulation loop, which fixes the charging battery voltage via a resistor divider.

It is possible to set the maximum output current according to charging requirements by a sense resistor .

The SPV1040 protects itself and other application devices by stopping the PWM switching if either the maximum current threshold (up to 1.8 A_{pk}) is reached or the maximum temperature limit (up to 155 °C) is exceeded. An additional built-in feature of the SPV1040 is the input source reverse polarity protection, which prevents damage in case of reverse connection of the solar panel on the input.

Product status link

[SPV1040](#)

Product summary

Order code	SPV1040T
Package	TSSOP8
Packing	Tube
Order code	SPV1040TR
Package	TSSOP8
Packing	Tape and reel

Product label



1 Block diagram

Figure 1. Block diagram

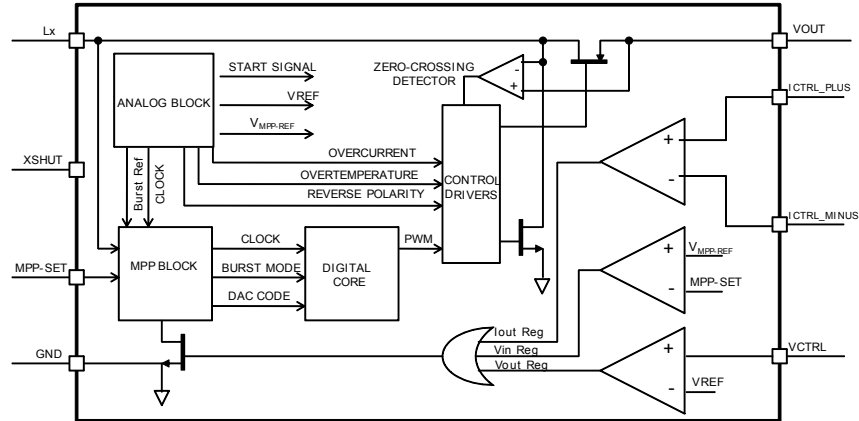
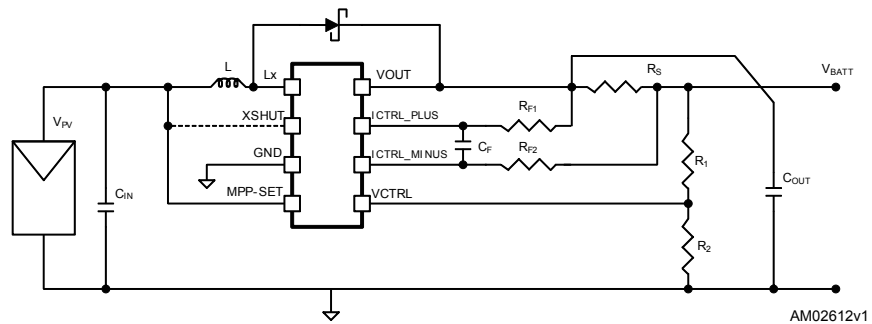

Figure 2. Simplified application circuit



In order to set up the application and simulate the related test results please go to www.st.com.

2 Pin description

Table 1. Pin description

Pin	Name	Type	Description
1	MPP-SET	I	Non-inverting input to sense the PV cell voltage. It cannot be left floating.
2	GND	Ground	Power ground reference.
8	XSHUT	I	Shutdown input pin: XSHUT = low, the device in power off mode. XSHUT = high, the device is enabled for operating mode. This pin cannot be left floating.
3	LX	I	Booster inductor connection.
7	ICTRL_PLUS	I	Non-inverting input of constant current control loop. Connect to GND if not used: cannot be left floating.
6	ICTRL_MINUS	I	Inverting input of constant current control loop. Connect to GND if not used: cannot be left floating.
5	VCTRL	I	Inverting input of constant current control loop. It cannot be left floating.
4	VOUT	O	Booster output voltage.

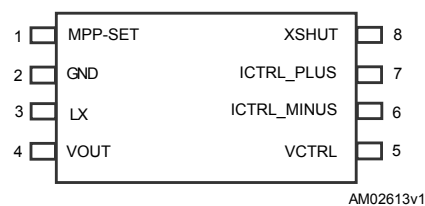
Figure 3. Pin connection top view

3 Electrical ratings

Table 2. Absolute maximum ratings

Symbol	Parameter	Value	Unit
MPP-SET	Analog input	[-5.5, VOUT]	V
GND	Ground	0	
XSHUT	Analog input	[-5.5, VOUT]	
LX	Analog input	[-5.5, VOUT]	
ICTRL_PLUS	Analog input	[-0.3, VOUT]	
ICTRL_MINUS	Analog input	[-0.3, VOUT]	
VCTRL	Analog input	[-0.3, VOUT]	
VOUT	Analog output	[-0.3, 5.5]	

Table 3. Thermal data

Symbol	Parameter	Value	Unit
$R_{thj-amb}$	Thermal resistance, junction-to-ambient	135	°C/W
T_{jop}	Junction operating temperature	-40 to 125	°C
T_{stg}	Storage temperature	-40 to 150	°C

Note: R_{thJA} has been measured on a 2-layer PCB: FR4, 35 μ m Cu thickness, 2.8 cm²

4 Electrical characteristics

$V_{MPP-SET} = 0.5\text{ V}$, $V_{CTRL} = I_{ctrl+} = I_{ctrl-} = \text{GND}$, $XSHUT = 0.5\text{ V}$, $T_J = -40\text{ }^\circ\text{C}$ to $125\text{ }^\circ\text{C}$, unless otherwise specified.

Table 4. Electrical characteristics

Symbol	Parameter	Test conditions	Min.	Typ.	Max.	Unit
Input source section						
$V_{MPP-SET}$	Low boost voltage threshold	$V_{OUT} = 3.3\text{ V}$	0.4	0.45	0.50	V
I_q	Quiescent current	$I_{LOAD} = 0\text{ mA}$, $V_{CTRL} = 2\text{ V}$, $V_{OUT} = 3.3\text{ V}$		60	80	μA
I_{SD}	Shutdown current	$V_{OUT} = 3.3\text{ V}$, $V_{CTRL} = 2\text{ V}$, $I_{LOAD} = 0\text{ mA}$, $XSHUT = \text{GND}$		0.7	5	
I_{rev}	Reverse input source current	$V_{MPP-SET} = -4\text{ V}$, $V_{OUT} = 1.5\text{ V}$		1	5	
V_{UVLO}	Undervoltage lockout threshold for turn ON @ $V_{OUT} = 3.3\text{ V}$	$V_{MPP-SET}$ increasing		0.27	0.34	V
	Undervoltage lockout threshold for turn OFF @ $V_{OUT} = 3.3\text{ V}$	$V_{MPP-SET}$ decreasing	0.14	0.24		
Power section						
$R_{DS(on)-N}$	N-channel power switch ON resistance				120	$\text{m}\Omega$
$R_{DS(on)-P}$	P-channel synchronous rectifier ON resistance	$V_{CTRL} = 2\text{ V}$			140	
Control section						
$V_{MPPT-THR}$	MPPT-mode threshold	V_{OUT} increasing, $V_{MPP-SET} = 1.5\text{ V}$	1.7	1.8	2	V
V_{OUT}	Output voltage range	$V_{MPP-SET} \geq 1.5\text{ V}$	2		5.2 ⁽¹⁾	V
P_{OUT} ⁽²⁾	Maximum output power	$V_{MPP-SET} \geq 1.5\text{ V}$			3	W
I_{LX}	Maximum inductor current peak		1.5	1.65	1.8	A

Symbol	Parameter	Test conditions	Min.	Typ.	Max.	Unit
F _{PWM}	PWM signal frequency		70	100	130	kHz
V _{REF}	Internal V _{CTRL} reference voltage	V _{OUT} ≥ 1.8 V, V _{CTRL} increasing	1.2	1.25	1.3	V
V _{CTRL}	Sensing current offset	I _{CTRL+} - I _{CTRL-} decreasing	40	50	60	mV
XSHUT	XSHUT logic low	XSHUT increasing		0.27	0.34	V
	XSHUT logic High	XSHUT decreasing	0.14	0.24		
Thermal shutdown						
T _{shutdown}	Overtemperature threshold for turn OFF	Temperature increasing		155		°C
	Overtemperature threshold for turn ON	Temperature decreasing		130		

1. According to the absolute maximum ratings the output charge voltage cannot be above 4.8 V but if a higher V_{OUT} up to 5.2 V is needed, a Schottky diode must be placed between the L_x and V_{OUT} pins as shown in [Figure 1](#). In such way the Schottky diode in parallel to the embedded P-channel MOSFET reduces the voltage drop between the VLX pin and the V_{OUT} pin determined by the body diode when the internal PMOS is OFF from 0.7 V down to 0.3 V.
2. Given $T_j = T_a + R_{thJA} \times P_D$, and assuming $R_{thJA} = 135 \text{ }^\circ\text{C/W}$, and that in order to avoid device destruction T_{jmax} must be ≤ 125 °C, and that in the worst conditions $T_A = 85 \text{ }^\circ\text{C}$, the power dissipated inside the device is given by: $P_D \leq (T_j - T_A) / R_{thJA} = 295 \text{ mW}$. Therefore, if in the worst case the efficiency is assumed to be 90%, then $P_{IN-MAX} = 3.3 \text{ W}$ and $P_{OUT-MAX} = 3 \text{ W}$.

5 Typical characteristics

Table 5. Typical Conversion Efficiency

$V_{IN}[V]$	$P_{IN}[W]$	$P_{OUT}/P_{IN}[\%]$
1.50	0.25 to 2.0	80% to 90%
2.00	0.25 to 2.5	80% to 95%
2.50	0.25 to 3.0	80% to 95%

Test conditions (ref to Figure 1):
 $10\mu H \leq L \leq 100\mu H$ ($L_{DCR} \leq 0.3\Omega$);
 $R_S = 0\Omega$; RF1, RF2 and CF unmounted;
 $ICTRL+ = ICTRL- = GND$

Figure 4. V_{LX} and I_{LX} waveforms - D = 39%

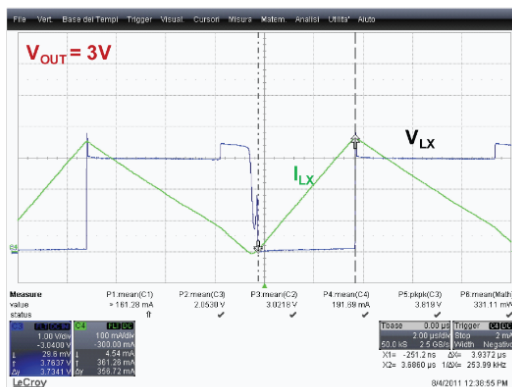
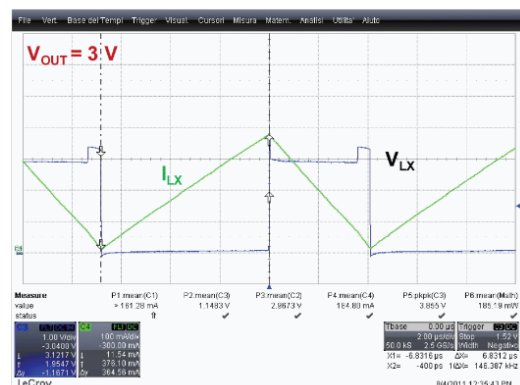

Figure 5. V_{LX} and I_{LX} waveforms - D = 68%



6 Detailed description

The SPV1040 is a monolithic, high efficiency, low voltage, self-powered DC-DC converter that operates over a 0.3 V to 5.5 V DC input voltage range and provides a single output voltage. The device provides regulated output voltage and current by sensing the VCTRL feedback of the external resistor divider and the voltage drop on the external sense resistor R_s , respectively. High efficiency is ensured by low power consumption in any working mode and by the embedded perturb and observe MPPT algorithm. The SPV1040 guarantees its own safety and application safety by stopping the N-channel power switch in case of overcurrent or overtemperature conditions.

6.1 Soft-start

In order to guarantee the power-up even when VOUT is very low (battery completely discharged), a proper start-up strategy has been implemented. Taking into account that the device is powered by the VOUT voltage, if VOUT is lower than 0.8 V, the device moves from power off to soft-start mode and the current flows from the input to output through the intrinsic body diode of the synchronous rectifier. In this condition VOUT follows the LX voltage. The IC exits start-up mode when VOUT reaches 0.8 V.

6.2 Start-up mode

When VOUT goes above 0.8 V but it is still lower than 2 V, a proper biasing of both MOSFETs is not guaranteed yet. In such conditions, the N-channel power switch is forced ON with a fixed duty cycle and the energy is transferred to the load via the intrinsic body diode of the P-channel synchronous switch. If the shutdown overcurrent limit is exceeded, the power switch is immediately turned OFF. The SPV1040 leaves start-up mode as soon as VOUT goes above 2 V.

6.3 MPPT mode

Once the device has exited start-up mode, the SPV1040 enters MPPT mode to search for the maximum power point. The perturb and observe algorithm is based on monitoring either the voltage or the current supplied by the DC power source unit so that the PWM signal duty cycle is increased or decreased step-by-step according to the input power trend. Refer to [Figure 6](#), which illustrates the MPPT working principle.

6.4 Constant voltage regulation

The constant voltage control loop consists of an internal voltage reference, an op-amp and an external resistor divider that senses the battery voltage and fixes the voltage regulation set-point at the value specified by the user.

6.5 Constant current regulation

The constant current control loop consists of an op-amp and an external sense resistor that feeds the current sensing circuit with a voltage proportional to the DC output current. This resistor determines the current regulation set-point and must be adequately rated in terms of power dissipation. It provides the capability to fix the maximum output current to protect the battery.

6.6 Overcurrent protection (OVC)

When the current that flows through the inductor reaches 1.8 A (overcurrent shutdown limit), the N-channel power switch is immediately forced OFF and the P-channel synchronous rectifier is switched ON. Once the overcurrent condition has expired (the inductor current goes below 1.8 A_{pk}) the N-channel power switch is turned back ON.

6.7 Overtemperature protection

When the temperature sensed at silicon level reaches 155 °C (overtemperature shutdown limit), the N-channel power switch is immediately forced OFF and the P-channel synchronous rectifier is switched ON. The device becomes operative again as soon as the silicon temperature goes below 130 °C.

6.8 Shutdown mode

The XSHUT pin low shuts OFF all internal circuitry, achieving the lowest power consumption mode.

6.9 Undervoltage lockout

In order to prevent batteries from over-discharging, the device turns OFF in case of MPPSET voltage is lower than 0.24 V (no irradiation). A hysteresis has been implemented to avoid unpredictable ON-OFF switching.

6.10 Reverse polarity

In order to avoid damage to the device and battery discharge when the solar panel connection is reverse-inserted, a dedicated protection circuit has been implemented. In such condition, the SPV1040 stays OFF until the panel is inserted correctly.

Figure 6. MPPT working principle

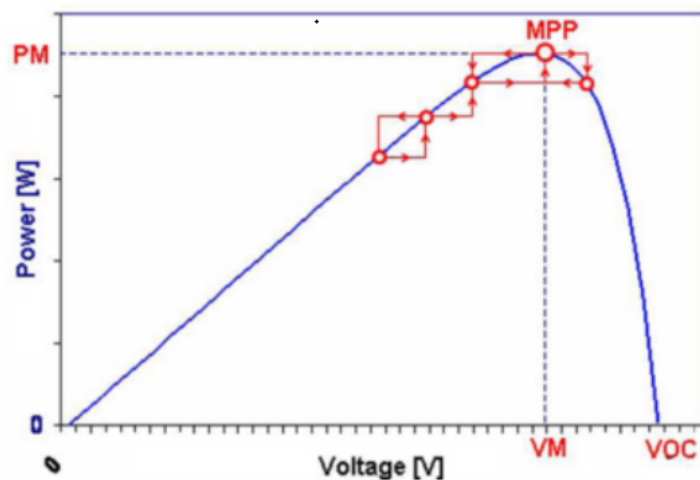

6.11 Burst mode

When the output voltage reaches the battery charge voltage, the MPP-SET voltage drops below 450 mV, or the output current reaches the output maximum current limit, the duty cycle D drops down to 10% and the device evolves from operating mode to burst mode. The converter no longer works at constant frequency, but at frequencies gradually lower (1 T_{ON} over 1 PWM cycle, 1 T_{ON} over 2 PWM cycles, ..., 1 T_{ON} over 16 PWM cycles) prior to entering sleep-in mode.

6.12 Sleep-in mode

Once sleep-in mode has been entered, no current is provided to the load. The device exits this mode once the cause, which forced it into this state, is no longer present.

7 Package information

In order to meet environmental requirements, ST offers these devices in different grades of ECOPACK[®] packages, depending on their level of environmental compliance. ECOPACK[®] specifications, grade definitions and product status are available at: www.st.com.

ECOPACK[®] is an ST trademark.

7.1 TSSOP8 package information

Figure 7. TSSOP8 package outline

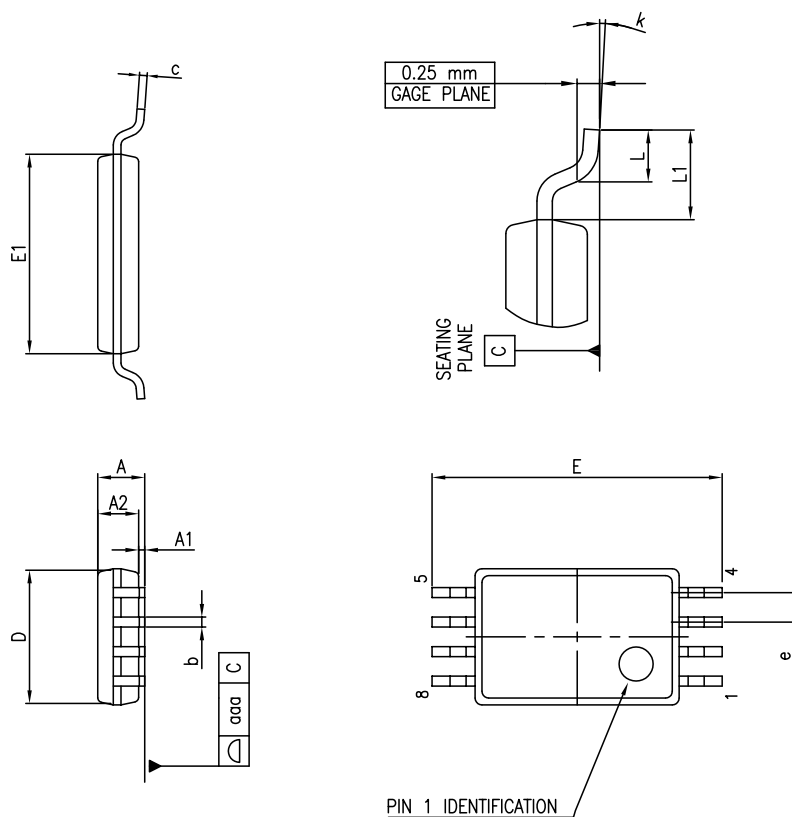

Table 6. TSSOP8 package mechanical data

Dim.	mm		
	Min.	Typ.	Max.
A			1.20
A1	0.05		0.15
A2	0.80	1.00	1.05
b	0.19		0.30
c	0.09		0.20
D	2.90	3.00	3.10
E	6.20	6.40	6.60
E1	4.30	4.40	4.50

Dim.	mm		
	Min.	Typ.	Max.
e		0.65	
L	0.45	0.60	0.75
L1		1.00	
L2		0.25	
k	0		8
aaa			0.10

Note: Dimensions D does not include mold flash or protrusions. Mold flash or protrusions do not exceed 0.15 mm per side.

Dimension E1 does not include interlead flash or protrusions. Interlead flash or protrusions do not exceed 0.25 mm per side.

7.2 TSSOP8 packing information

Figure 8. TSSOP8 carrier tape outline

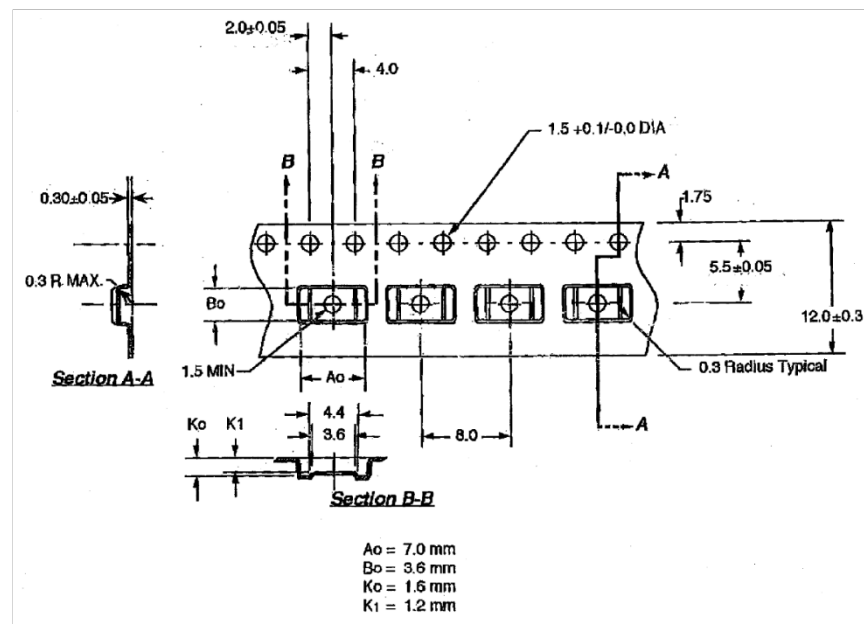
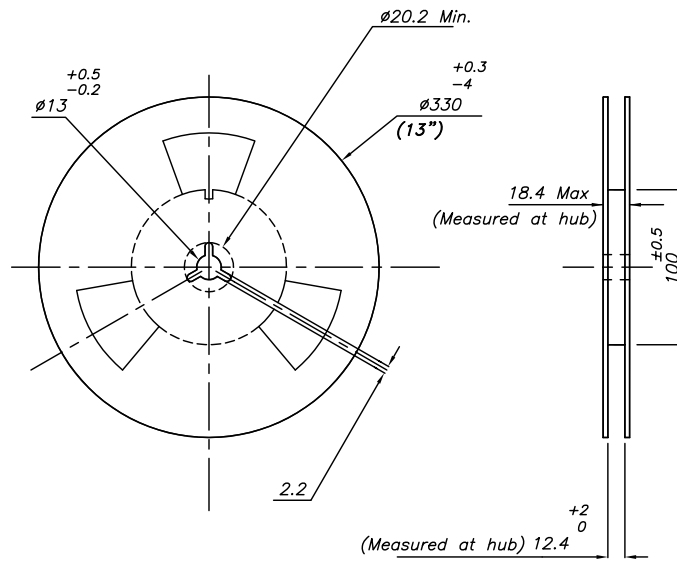

Figure 9. TSSOP8 reel outline



Revision history

Table 7. Document revision history

Date	Revision	Changes
08-Oct-2010	1	First release.
06-Apr-2011	2	Updated the cover page, DFN8 information deleted, <i>Chapter 3</i> , <i>Chapter 4</i> and <i>Chapter 6</i> .
04-Oct-2011	3	– Updated <i>Figure 1</i> , <i>Figure 2</i> , <i>Table 2</i> and <i>Table 5</i> – Minor text changes.
25-Jul-2012	4	Updated <i>Figure 4</i> , <i>Figure 5</i> , <i>Figure 6</i> , <i>Figure 7</i> , <i>Figure 8</i> , and <i>Figure 9</i> .
21-Mar-2013	5	Updated <i>Figure 1</i> and <i>note 1</i> in <i>Table 5</i> .
26-Sep-2016	6	Added <i>Section 7.2</i> : " <i>Packing information</i> ".
06-Feb-2017	7	Update TSSOP8 package information.
17-Jan-2020	8	Figures from 4 to 9 replaced by Table 5 ; minor text changes.

Contents

1	Block diagram	2
2	Pin description	3
3	Electrical ratings	4
4	Electrical characteristics	5
5	Typical characteristics	7
6	Detailed description	8
6.1	Soft-start	8
6.2	Start-up mode	8
6.3	MPPT mode	8
6.4	Constant voltage regulation	8
6.5	Constant current regulation	8
6.6	Overcurrent protection (OVC)	8
6.7	Overtemperature protection	8
6.8	Shutdown mode	8
6.9	Undervoltage lockout	9
6.10	Reverse polarity	9
6.11	Burst mode	9
6.12	Sleep-in mode	9
7	Package information	10
7.1	TSSOP8 package information	10
7.2	TSSOP8 packing information	11
	Revision history	13
	Contents	14
	List of tables	15
	List of figures	16

List of tables

Table 1.	Pin description	3
Table 2.	Absolute maximum ratings	4
Table 3.	Thermal data	4
Table 4.	Electrical characteristics	5
Table 5.	Typical Conversion Efficiency	7
Table 6.	TSSOP8 package mechanical data	10
Table 7.	Document revision history	13

List of figures

Figure 1.	Block diagram	2
Figure 2.	Simplified application circuit	2
Figure 3.	Pin connection top view	3
Figure 4.	V_{LX} and I_{LX} waveforms - $D = 39\%$	7
Figure 5.	V_{LX} and I_{LX} waveforms - $D = 68\%$	7
Figure 6.	MPPT working principle	9
Figure 7.	TSSOP8 package outline	10
Figure 8.	TSSOP8 carrier tape outline	11
Figure 9.	TSSOP8 reel outline	12

IMPORTANT NOTICE – PLEASE READ CAREFULLY

STMicroelectronics NV and its subsidiaries (“ST”) reserve the right to make changes, corrections, enhancements, modifications, and improvements to ST products and/or to this document at any time without notice. Purchasers should obtain the latest relevant information on ST products before placing orders. ST products are sold pursuant to ST’s terms and conditions of sale in place at the time of order acknowledgement.

Purchasers are solely responsible for the choice, selection, and use of ST products and ST assumes no liability for application assistance or the design of Purchasers’ products.

No license, express or implied, to any intellectual property right is granted by ST herein.

Resale of ST products with provisions different from the information set forth herein shall void any warranty granted by ST for such product.

ST and the ST logo are trademarks of ST. For additional information about ST trademarks, please refer to www.st.com/trademarks. All other product or service names are the property of their respective owners.

Information in this document supersedes and replaces information previously supplied in any prior versions of this document.

© 2020 STMicroelectronics – All rights reserved