



STA323WQS

2.1-channel high-efficiency digital audio system with QSound QHD[®]

Features

- Wide supply voltage range (10 V - 36 V)
- Three power output configurations
 - 2 x 10 W + 1 x 20 W
 - 2 x 20 W
 - 1 x 40 W
- Thermal protection
- Under-voltage protection
- Short-circuit protection
- PowerSO-36 slug down package
- 2.1 channels of 24-bit DDX[®]
- 100-dB SNR and dynamic range
- 32 kHz to 192 kHz input sample rates
- Digital gain/attenuation +48 dB to -80 dB in 0.5-dB steps
- Four 28-bit user programmable bi-quads (EQ) per channel
- I²C control
- 2-channel I²S input data interface
- Individual channel and master gain/attenuation
- Individual channel and master soft and hard mute
- Individual channel volume and EQ bypass
- DDX[®] POP free operation
- Bass/treble tone control
- Dual independent programmable limiters/compressors
- AutoModes
 - 32 preset EQ curves
 - 15 preset crossover settings
 - Auto volume controlled loudness
 - 3 preset volume curves
 - 2 preset anti-clipping modes
 - Preset night-time listening mode
 - Preset TV AGC

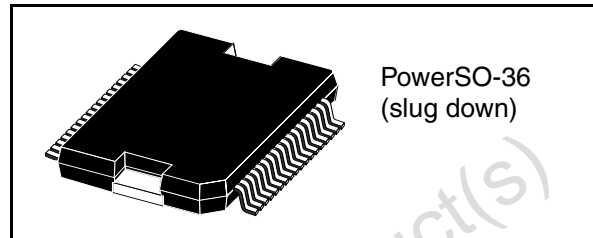

- Input and output channel mapping
- AM noise-reduction and PWM frequency shifting modes
- Soft volume update and muting
- Auto zero detect and invalid input detect muting selectable DDX[®] ternary or binary PWM output plus variable PWM speeds
- Selectable de-emphasis
- Post-EQ user programmable mix with default 2.1 bass-management settings
- Variable max power correction for lower full-power THD
- Four output routing configurations
- Selectable clock input ratio
- 96 kHz internal processing sample rate, 24 to 28-bit precision
- Video application supports 576 * fs input mode
- QSound QHD[®]
 - Field proven stereo soundfield enhancement technology
 - Provides improved audio image width, separation and depth for stereo signals
 - Synthesizes a 3-D stereo soundfield

Table 1. Device summary

Order code	Package
STA323WQS	PowerSO-36 (slug down)
STA323WQS13TR	PowerSO-36 in tape & reel

Contents

1	Description	10
1.1	Block diagram and configurations	11
1.2	EQ processing	11
1.3	Output options	12
2	Applications	13
3	Pin out	15
3.1	Pin numbering	15
3.2	Pin description	16
4	Electrical specifications	18
4.1	General interface specifications	18
4.2	DC electrical specifications (3.3 V buffers)	19
4.3	Power electrical specifications	19
4.4	Timing specifications	20
4.5	Power supply and control sequencing	21
5	Electrical characteristics curves	22
5.1	Output power against supply voltage	22
5.2	Audio performance	24
5.2.1	Stereo mode, operation with $V_{CC} = 26\text{ V}$, $8\ \Omega$ load	24
5.2.2	Stereo mode, operation with $V_{CC} = 18.5\text{ V}$	25
5.2.3	Half-bridge binary mode, operation with $V_{CC} = 18.5\text{ V}$	29
6	I²C bus specification	34
6.1	Communication protocol	34
6.2	Device addressing	34
6.3	Write operation	35
6.4	Read operation	35
7	Register descriptions	37
7.1	Configuration register A (address 0x00)	38

7.1.1	Master clock select	38
7.1.2	Interpolation ratio select	39
7.1.3	Thermal warning recovery bypass	40
7.1.4	Thermal warning adjustment bypass	40
7.1.5	Fault detect recovery bypass	40
7.2	Configuration register B (address 0x01)	41
7.2.1	Serial audio input interface format	41
7.2.2	Serial data interface	41
7.2.3	Delay serial clock enable	43
7.3	Configuration register C (address 0x02)	44
7.3.1	DDX® power-output mode	44
7.3.2	DDX® variable compensating pulse size	44
7.4	Configuration register D (address 0x03)	45
7.4.1	High-pass filter bypass	45
7.4.2	De-emphasis	45
7.4.3	DSP bypass	45
7.4.4	Post-scale link	46
7.4.5	Biquad coefficient link	46
7.4.6	Dynamic range compression/anti-clipping bit	46
7.4.7	Zero-detect mute enable	46
7.5	Configuration register E (address 0x04)	47
7.5.1	Max power correction variable	47
7.5.2	Max power correction	47
7.5.3	AM mode enable	47
7.5.4	PWM speed mode	47
7.5.5	Zero-crossing volume enable	48
7.5.6	Soft volume update enable	48
7.6	Configuration register F (address 0x05)	48
7.6.1	Output configuration selection	48
7.7	Volume control	50
7.7.1	Master controls	50
7.7.2	Channel controls	50
7.7.3	Volume description	50
7.8	AutoMode registers	52
7.8.1	AutoModes EQ, volume, GC (address 0x0B)	52
7.8.2	AutoMode AM/pre-scale/bass management scale (address 0x0C)	53

7.8.3	Preset EQ settings (address 0x0D)	54
7.9	Channel configuration registers	55
7.9.1	Channel 1 configuration (address 0x0E)	55
7.9.2	Channel 2 configuration (address 0x0F)	55
7.9.3	Channel 3 configuration (address 0x10)	55
7.10	Tone control (address 0x11)	57
7.11	Dynamics control	57
7.11.1	Limiter 1 attack/release threshold (address 0x12)	57
7.11.2	Limiter 1 attack/release threshold (address 0x13)	57
7.11.3	Limiter 2 attack/release rate (address 0x14)	57
7.11.4	Limiter 2 attack/release threshold (address 0x15)	58
7.11.5	Dynamics control description	58
7.11.6	Anti-clipping mode	60
7.11.7	Dynamic range compression mode	61
8	User-programmable settings	63
8.1	EQ - biquad equation	63
8.2	Pre-scale	63
8.3	Post-scale	63
8.4	Mix/bass management	64
8.5	Calculating 24-bit signed fractional numbers from a dB value	65
8.6	User defined coefficient RAM	65
8.6.1	Coefficient address register 1 (address 0x16)	65
8.6.2	Coefficient b1 data register bits 23:16 (address 0x17)	65
8.6.3	Coefficient b1 data register bits 15:8 (address 0x18)	65
8.6.4	Coefficient b1 data register bits 7:0 (address 0x19)	65
8.6.5	Coefficient b2 data register bits 23:16 (address 0x1A)	65
8.6.6	Coefficient b2 data register bits 15:8 (address 0x1B)	66
8.6.7	Coefficient b2 data register bits 7:0 (address 0x1C)	66
8.6.8	Coefficient a1 data register bits 23:16 (address 0x1D)	66
8.6.9	Coefficient a1 data register bits 15:8 (address 0x1E)	66
8.6.10	Coefficient a1 data register bits 7:0 (address 0x1F)	66
8.6.11	Coefficient a2 data register bits 23:16 (address 0x20)	66
8.6.12	Coefficient a2 data register bits 15:8 (address 0x21)	66
8.6.13	Coefficient a2 data register bits 7:0 (address 0x22)	67
8.6.14	Coefficient b0 data register bits 23:16 (address 0x23)	67

8.6.15	Coefficient b0 data register bits 15:8 (address 0x24)	67
8.6.16	Coefficient b0 data register bits 7:0 (address 0x25)	67
8.6.17	Coefficient write control register (address 0x26)	67
8.7	Reading and writing coefficients	68
8.7.1	Reading a coefficient from RAM	68
8.7.2	Reading a set of coefficients from RAM	68
8.7.3	Writing a single coefficient to RAM	68
8.7.4	Writing a set of coefficients to RAM	69
8.8	Variable max power correction (address 0x27-0x28)	70
8.9	Fault detect recovery (address 0x2B - 0x2C)	71
8.10	Status indicator register (address 0x2D)	71
8.10.1	Thermal warning indicator	71
8.10.2	Fault detect indicator	71
8.10.3	PLL unlock indicator	72
9	Package information	73
10	License information	75
11	Trademarks and other acknowledgements	76
12	Revision history	77

Obsolete Product(s) - Obsolete Product(s)
 Obsolete Product(s) - Obsolete Product(s)

List of tables

Table 1.	Device summary	1
Table 2.	Component selection "Table A" - full-bridge operation	13
Table 3.	Component selection "Table B" - binary half-bridge operation	13
Table 4.	Component selection "Table C" - mono operation	13
Table 5.	Pin list	15
Table 6.	Absolute maximum ratings	18
Table 7.	Thermal data	18
Table 8.	Recommended DC operating conditions	18
Table 9.	General interface electrical characteristics	18
Table 10.	DC electrical characteristics	19
Table 11.	Power electrical characteristics	19
Table 12.	Timing characteristics	20
Table 13.	Register summary	37
Table 14.	Master clock select	38
Table 15.	IR and MCS settings for input sample rate and clock rate	39
Table 16.	Interpolation ratio select	39
Table 17.	IR bit settings as a function of input sample rate	39
Table 18.	Thermal warning recovery bypass	40
Table 19.	Thermal warning adjustment bypass	40
Table 20.	Fault detect recovery bypass	40
Table 21.	Serial audio input interface format	41
Table 22.	Supported serial audio input formats	42
Table 23.	Serial input data timing characteristics ($f_s = 32$ to 192 kHz)	43
Table 24.	Delay serial clock enable	43
Table 25.	Channel input mapping	43
Table 26.	DDX® power-output mode	44
Table 27.	DDX® output modes	44
Table 28.	DDX® compensating pulse	44
Table 29.	High-pass filter bypass	45
Table 30.	De-emphasis	45
Table 31.	DSF bypass	45
Table 32.	Post-scale link	46
Table 33.	Biquad coefficient link	46
Table 34.	Dynamic range compression/anti-clipping bit	46
Table 35.	Zero-detect mute enable	46
Table 36.	Max power correction variable	47
Table 37.	Max power correction	47
Table 38.	AM mode enable	47
Table 39.	PWM speed mode	47
Table 40.	PWM output speed selections	48
Table 41.	Zero-crossing volume enable	48
Table 42.	Soft volume update enable	48
Table 43.	Output configuration selection	48
Table 44.	Output configuration selections	49
Table 45.	Invalid input detect mute enable	49
Table 46.	Binary clock loss detection enable	49
Table 47.	Auto-EAPD on clock loss enable	49
Table 48.	External amplifier power down	49

Table 49.	Master volume offset as a function of MV[7:0]	51
Table 50.	Channel volume as a function of CxV[7:0]	51
Table 51.	Automode EQ	52
Table 52.	Automode volume	52
Table 53.	Automode gain compression/limiters	52
Table 54.	AMPS - automode auto pre scale	52
Table 55.	Automode AM switching enable	53
Table 56.	Automode AM switching frequency selection	53
Table 57.	Automode crossover setting	53
Table 58.	Crossover frequency selection	53
Table 59.	Preset EQ selection	54
Table 60.	Channel Limiter Mapping Selection	56
Table 61.	Channel PWM output mapping	56
Table 62.	Tone control boost/cut selection	57
Table 63.	Limiter attack rate selection	59
Table 64.	Limiter release rate selection	59
Table 65.	Limiter attack - threshold selection (AC-mode)	60
Table 66.	Limiter release threshold selection (AC-mode)	60
Table 67.	Limiter attack - threshold selection (DRC-mode)	61
Table 68.	Limiter release threshold selection (DRC-mode)	62
Table 69.	RAM block for biquads, mixing, and scaling	69
Table 70.	Thermal warning indicator	71
Table 71.	Fault detect indicator	71
Table 72.	PLL unlock indicator	72
Table 73.	PowerSO-36 slug down dimensions	74
Table 74.	Document revision history	77

Obsolete Product(s) - Obsolete Product(s)
 Obsolete Product(s) - Obsolete Product(s)

List of figures

Figure 1.	Block diagram	11
Figure 2.	Channel signal flow diagram through the digital core	11
Figure 3.	Channel signal flow diagram through the EQ block	11
Figure 4.	2-channel (full-bridge) power, OCFG[1:0] = 00	12
Figure 5.	2.1-channel power configuration, OCFG[1:0] = 01	12
Figure 6.	1-channel mono-parallel configuration, OCFG[1:0] = 11	12
Figure 7.	Schematic for 2 (half-bridge) channels + 1 (full-bridge) channel	13
Figure 8.	Power schematic for 2 (full-bridge) channels	14
Figure 9.	Power schematic for 1 mono parallel channel	14
Figure 10.	Package pins (viewed from top of device)	15
Figure 11.	Test circuit 1	20
Figure 12.	Test circuit 2	21
Figure 13.	Recommended power up and power down sequence	21
Figure 14.	Stereo mode - output power vs. supply voltage, THD+N = 10%	22
Figure 15.	Output power vs. supply for stereo bridge, THD+N=1%	22
Figure 16.	Half-bridge binary mode output power vs. supply, THD+N=10%	23
Figure 17.	Half-bridge binary mode output power vs. supply voltage THD+N=1%	23
Figure 18.	Typical efficiency	24
Figure 19.	Typical frequency response	24
Figure 20.	FFT -60 dB, 1 kHz output	24
Figure 21.	FFT inter-modulation distortion 19 kHz and 20 kHz	25
Figure 22.	Frequency response, 1 W, BTL, 8 Ω	25
Figure 23.	Channel separation, 1 W, BTL stereo mode.	25
Figure 24.	THD vs. output power, BTL, 1 kHz	26
Figure 25.	THD vs. frequency, 1 W output, stereo mode.	26
Figure 26.	THD vs. frequency, BTL, 16 W output	26
Figure 27.	FFT 0 dBFS 1 kHz, 8 Ω	27
Figure 28.	FFT 0 dBFS 1 kHz, 1 kHz 6 Ω	27
Figure 29.	FFT 0 dBFS 1 kHz, 1 kHz 4 Ω	27
Figure 30.	FFT -60 dBFS 1 kHz, 8 Ω	28
Figure 31.	FFT -60 dBFS 1 kHz, 6 Ω	28
Figure 32.	FFT -60 dBFS 1 kHz, 4 Ω	28
Figure 33.	PSRR BTL, 500 mV ripple	29
Figure 34.	Frequency response, 1 W, binary half-bridge mode	29
Figure 35.	Channel separation, 1 W, half bridge binary.	29
Figure 36.	THD+N vs. output power, single ended, 1 kHz, half-bridge binary.	30
Figure 37.	THD vs. frequency, single ended, 1 W	30
Figure 38.	THD vs. frequency, single ended, 8 W	30
Figure 39.	FFT 0 dB, 1 kHz, single ended, 2 Ω	31
Figure 40.	FFT 0 dB, 1 kHz, single ended, 3 Ω	31
Figure 41.	FFT 0 dB, 1 kHz, single ended, 4 Ω	31
Figure 42.	FFT -60 dB, single ended, 1 kHz, 2 Ω	32
Figure 43.	FFT -60 dB, single ended, 1 kHz, 4 Ω	32
Figure 44.	FFT -60 dB, single ended, 1 kHz, 3 Ω	32
Figure 45.	PSRR single ended, 500 mV ripple	33
Figure 46.	I ² C write procedure	35
Figure 47.	I ² C read procedure	35
Figure 48.	General serial input and output formats	41

Figure 49.	Serial input and data timing	43
Figure 50.	Basic limiter and volume flow diagram	58
Figure 51.	Biquad filter	63
Figure 52.	Mix/bass management block diagram	64
Figure 53.	PowerSO-36 slug down outline drawing	73

Obsolete Product(s) - Obsolete Product(s)
Obsolete Product(s) - Obsolete Product(s)

1 Description

The STA323WQS is a single-chip audio system comprising digital audio processing, digital amplifier control, a DDX[®] power-output stage and QSound QHD[®]. The STA323WQS uses all-digital amplification to provide high-power, high-quality and high-efficiency.

The STA323WQS power section consists of four independent half-bridges. These can be configured, by digital control, to operate in the following modes.

- Two channels, provided by two half-bridges, and a single full-bridge giving up to 2 x 10 W + 1 x 20 W of power output.
- Two channels, provided by two full-bridges, giving up to 2 x 20 W of power.
- A single, parallel, full-bridge channel capable of high-current operation and giving 1 x 40W output.

The STA323WQS also provides a full set of digital processing features. This includes up to four programmable 28-bit biquads (EQ) per channel, and bass and treble tone control. AutoModes enable a time-to-market advantage by substantially reducing the amount of software development needed for specific functions. These include auto volume loudness, preset volume curves and preset EQ settings. New advanced AM radio-interference reduction modes are also provided.

The serial audio data input interface accepts all existing formats, including the I²S.

Three channels of DDX[®] processing are provided. This high-quality conversion from PCM audio to DDX patented 3-state PWM switching provides over 100 dB of SNR and dynamic range.

QSound QHD[®]

Normally, reduced audio clarity is experienced due to the digital compression of music (and video-sound) combined with various audio processing techniques used in broadcast transmission. This is most apparent in products such as digital televisions and audio players. These devices are faced with a multitude of audio challenges, primarily associated with the small speakers, that are limited in location and cabinet housing, plus economized speaker drivers and components. As such, digital televisions and audio players are ideal candidates to benefit from stereo soundfield enhancement in order to deliver a full surround-like experience.

QSound QHD[®] and its industry recognized QXpander[®] technology is a field-proven stereo soundfield enhancement technology that provides a broader stereo image width with greater separation and depth for stereo signals and synthesizes a 3-D stereo soundfield. QHD[®] removes the small centralized audio sweet spot by creating a very wide stereo image with full surrounding audio. QHD[®] and its QXpander[®] technology have been incorporated into hundreds of QSound and third party hardware and software products, with total shipments in the millions.

1.1 Block diagram and configurations

Figure 1. Block diagram

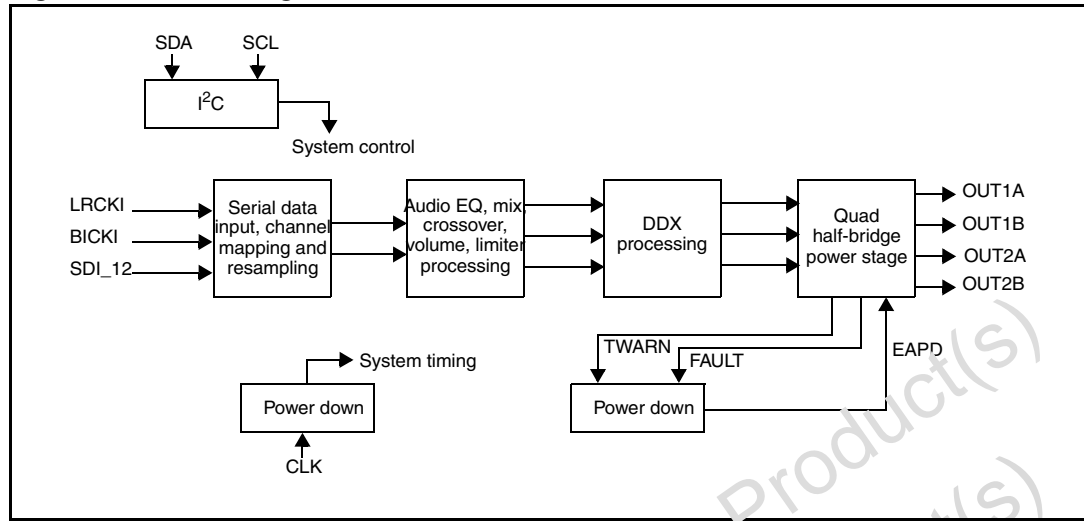
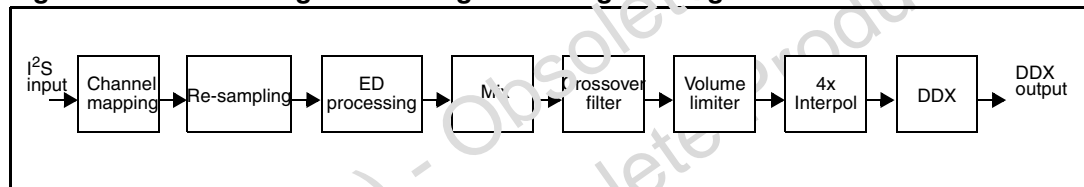

Figure 2. Channel signal flow diagram through the digital core



1.2 EQ processing

Two channels of input data (re-sampled if necessary) at 96 kHz are provided to the EQ processing block. In these blocks, up to four user-defined Biquads can be applied to each of the two channels.

Pre-scaling, DC-blocking high-pass, de-emphasis, bass, and tone control filters can also be implemented by means of configuration parameter settings.

The entire EQ block can be bypassed for all channels simultaneously by setting the DSPB bit to '1'. The CxEQBP bits can also be used to bypass the EQ functionality on a per channel basis. [Figure 3](#) shows the internal signal flow through the EQ block.

Figure 3. Channel signal flow diagram through the EQ block

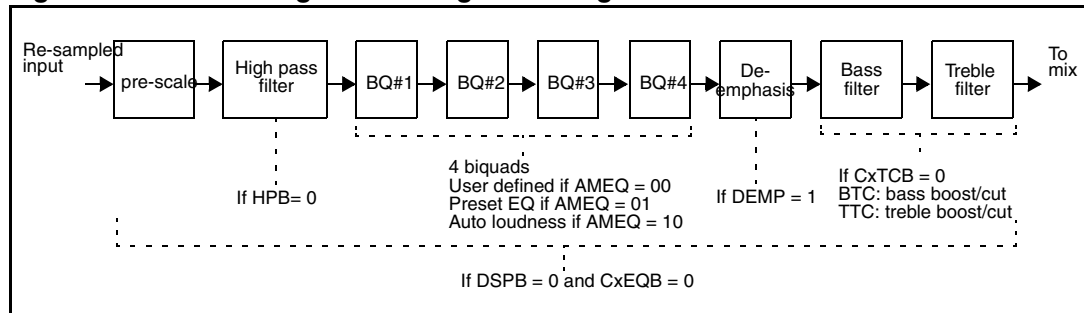

1.3 Output options

Figure 4. 2-channel (full-bridge) power, OCFG[1:0] = 00

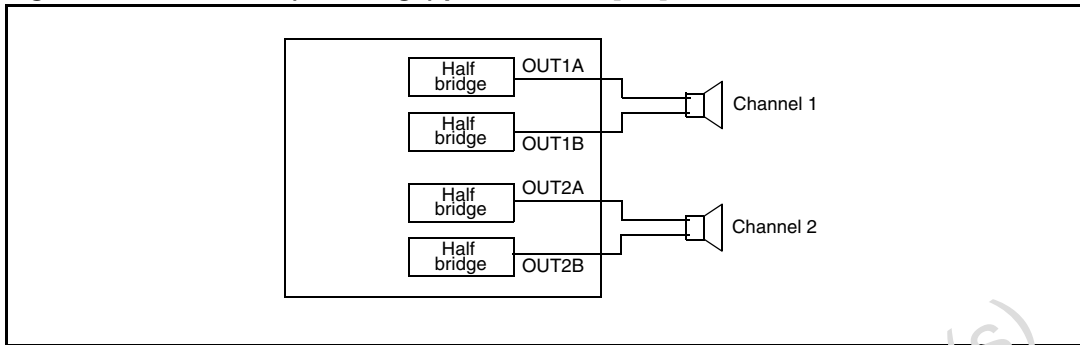

Figure 5. 2.1-channel power configuration, OCFG[1:0] = 01

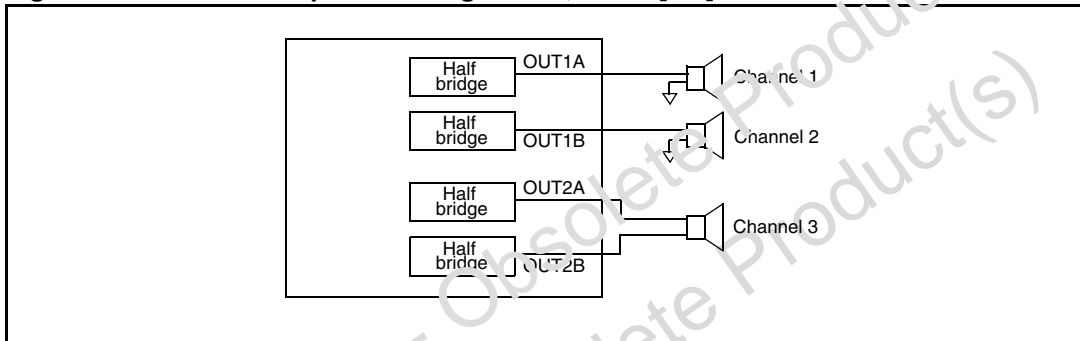
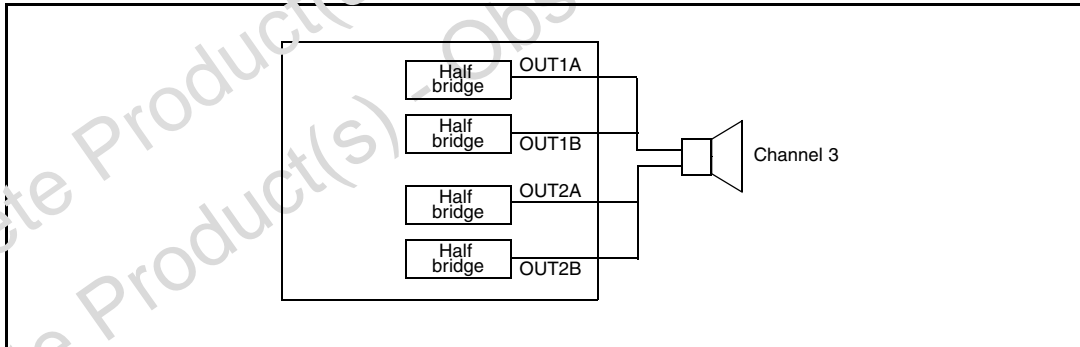

Figure 6. 1-channel mono-parallel configuration, OCFG[1:0] = 11



2 Applications

Table 2. Component selection "Table A" - full-bridge operation

Load	Inductor	Capacitor
4 Ω	10 μH	1.0 μF
6 Ω	15 μH	470 nF
8 Ω	22 μH	470 nF

Table 3. Component selection "Table B" - binary half-bridge operation

Load	Inductor	Capacitor
4 Ω	22 μH	680 nF
6 Ω	33 μH	470 nF
8 Ω	47 μH	390 nF

Table 4. Component selection "Table C" - mono operation

Load	Inductor	Capacitor
2 Ω	4.7 μH	2.0 μF
3 Ω	3.3 μH	1.0 μF
4 Ω	10 μH	1.0 μF

Figure 7. Schematic for 2 (half-bridge) channels + 1 (full-bridge) channel

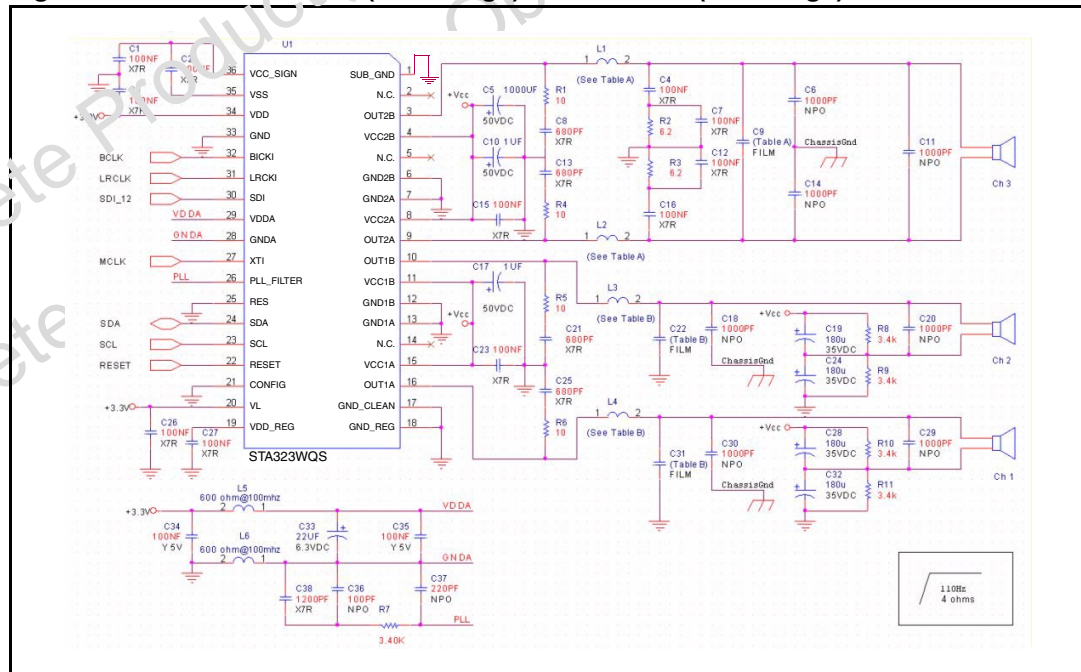

Figure 8. Power schematic for 2 (full-bridge) channels

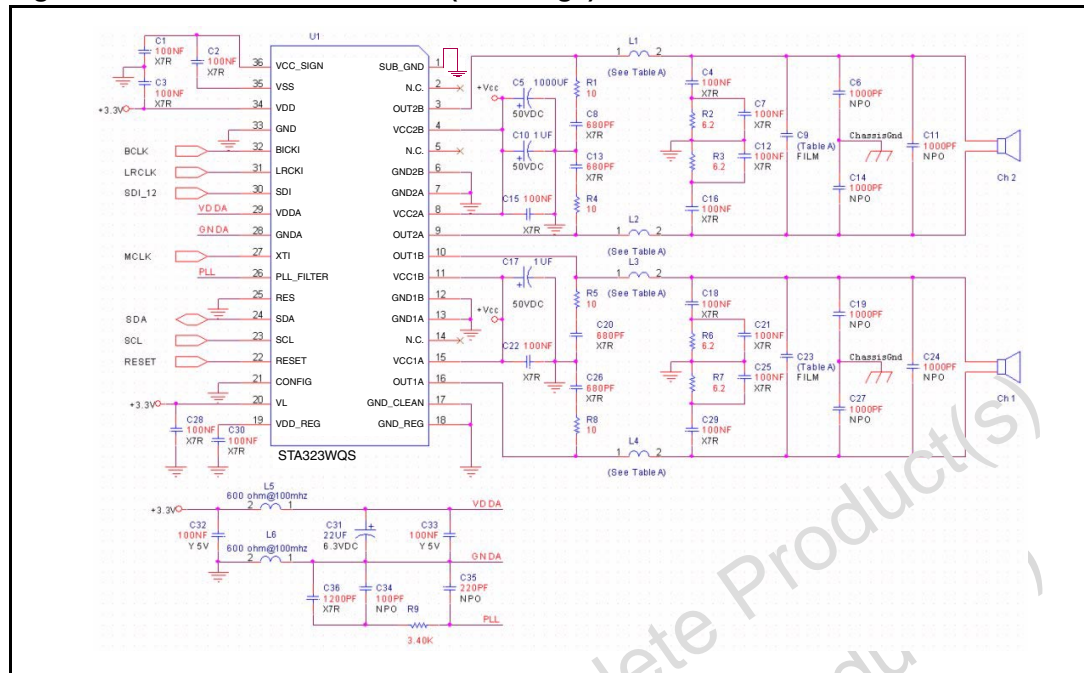
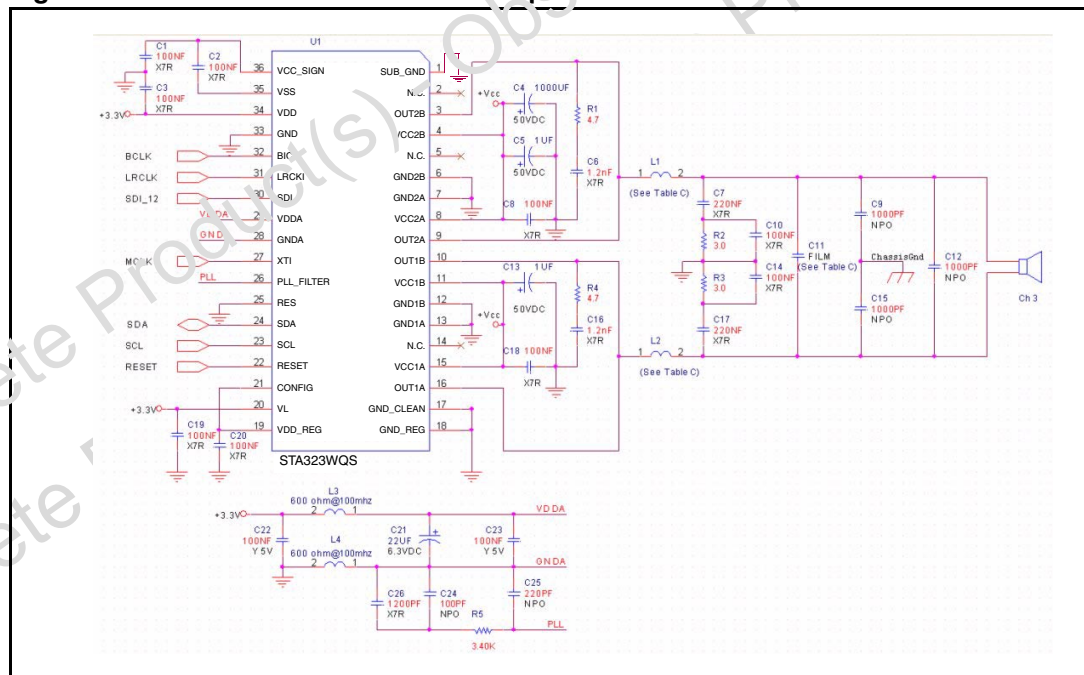

Figure 9. Power schematic for 1 mono parallel channel



3 Pin out

3.1 Pin numbering

Figure 10. Package pins (viewed from top of device)

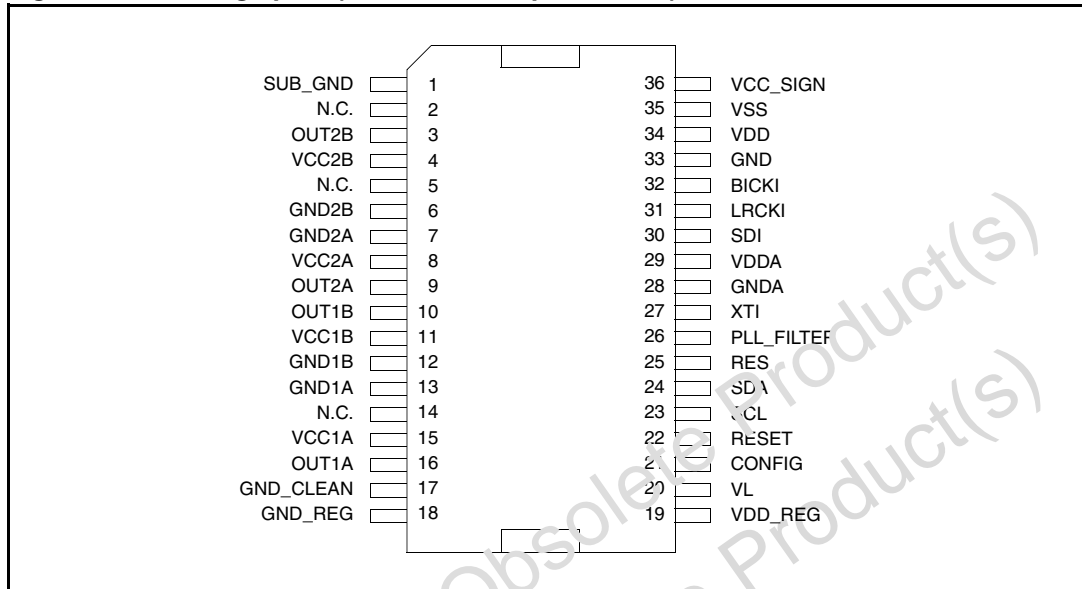

Table 5. Pin list

Pin	Type	Name	Description
1	I/O	SUB_GND	Ground
2	N.C.	N.C.	Not connected
3	O	OUT2B	Output half bridge 2B
4	I/O	VCC2B	Positive supply
5	N.C.	N.C.	Not connected
6	I/O	GND2B	Negative supply
7	I/O	GND2A	Negative supply
8	I/O	VCC2A	Positive supply
9	O	OUT2A	Output half bridge 2A
10	O	OUT1B	Output half bridge 1B
11	I/O	VCC1B	Positive supply
12	I/O	GND1B	Negative supply
13	I/O	GND1A	Negative supply
14	N.C.	N.C.	Not connected
15	I/O	VCC1A	Positive supply
16	O	OUT1A	Output half bridge 1A

Table 5. Pin list (continued)

Pin	Type	Name	Description
17	I/O	GND_CLEAN	Reference ground
18	I/O	GND_REG	Substrate ground
19	I/O	VDD_REG	Logic supply
20	I/O	VL	Logic supply to power section
21	I	CONFIG	Logic levels
22	I	RESET	Reset
23	I	SCL	I ² C serial clock
24	I/O	SDA	I ² C serial data
25	-	RES	Reserved test pin must be connected to ground
26	I	PLL_FILTER	Connection to PLL filter
27	I	XTI	PLL input clock
28	I/O	GNDA	Analog ground
29	I/O	VDDA	Analog supply 3.3
30	I	SDI_12	I ² S serial data channels 1 and 2
31	I/O	LRCKI	I ² S left/right clock
32	I	BICKI	I ² S serial clock
33	I/O	GND	Digital ground
34	I/O	VDD	Digital supply 3.3 V
35	I/O	VSS	5 V regulator referred to Vcc
36	I/O	VCC_SIGN	5 V regulator referred to ground

3.2 Pin description

OUT1A, 1B, 2A and 2B (pins 16, 10, 9 and 3)

The half-bridge PWM outputs 1A, 1B, 2A and 2B provide the inputs signals to the speakers.

RESET (pin 22)

Driving RESET low sets all outputs low and returns all register settings to their default (reset) values. The reset is asynchronous to the internal clock.

SDA, SCL (pins 24, 23)

The SDA (I²C Data) and SCL (I²C Clock) pins operate according to the I²C specification (See [Chapter 6 on page 34](#).) Fast-mode (400 kB/s) I²C communication is supported.

VDDA, GNDA (pins 29,28)

The phase locked loop power is applied here. This +3.3V supply must be well decoupled and filtered for good noise immunity since the audio performance of the device depends upon the PLL circuit.

CLK (pin 27)

This is the master clock input used by the digital core. The master clock must be an integer multiple of the LR clock frequency. Typically, the master clock frequency is 12.288 MHz ($256 * f_s$) for a 48kHz sample rate; it is the default setting at power-up. Care must be taken to provide the device with the nominal system clock frequency; over-clocking the device may result in anomalous operation, such as inability to communicate.

PLL_FILTER (pin 26)

This is the connection for the external filter components for the PLL loop compensation. Refer to the schematic diagram [Figure 9: Power schematic for 1 mono parallel channel on page 14](#) for the recommended circuit.

BICKI (pin 32)

The serial or bit clock input is for framing each data bit. The bit clock frequency is typically $64 * f_s$ using I²S serial format.

SDI (pin 30)

This is the serial data input where PCM audio information enters the device. Six format choices are available including I²S, left or right justified, LSE or MSB first, with word widths of 16, 18, 20 and 24 bits.

LRCKI (pin 31)

The left/right clock input is for data word framing. The clock frequency is at the input sample rate, f_s .

4 Electrical specifications

Table 6. Absolute maximum ratings

Symbol	Parameter	Value	Unit
V _{DD_3.3}	3.3 V I/O power supply	-0.5 to 4	V
V _i	Voltage on input pins	-0.5 to (V _{DD} +0.5)	V
V _o	Voltage on output pins	-0.5 to (V _{DD} +0.5)	V
T _{stg}	Storage temperature	-40 to +150	°C
T _{amb}	Ambient operating temperature	-40 to +85	°C
V _{CC}	DC supply voltage	40	V
V _{MAX}	Maximum voltage on pin 20	5.5	V

Table 7. Thermal data

Symbol	Parameter	Min	Typ	Max	Unit
R _{thj-case}	Thermal resistance junction to case (thermal pad)			2.5	°C/W
T _{j-SD}	Thermal shut-down junction temperature		150		°C
T _{WARN}	Thermal warning temperature		130		°C
T _{h-SD}	Thermal shut-down hysteresis		25		°C

Table 8. Recommended DC operating conditions

Symbol	Parameter	Value	Unit
V _{DD_3.3}	I/O power supply	3.0 to 3.6	V
T _j	Operating junction temperature	-40 to +125	°C

4.1 General interface specifications

Operating conditions V_{DD33} = 3.3 V ±0.3 V, T_{amb} = 25° C unless otherwise specified.

Table 9. General interface electrical characteristics

Symbol	Parameter	Test Condition	Min.	Typ.	Max.	Unit
I _{il}	Leakage current: low level input, no pull-up	V _i = 0 V ⁽¹⁾			1	μA
I _{ih}	Leakage current: high level input, no pull-down	V _i = V _{DD33} ⁽¹⁾			2	μA
I _{oZ}	Leakage current: 3-state output without pull-up/down	V _i = V _{DD33} ⁽¹⁾			2	μA
V _{esd}	Electrostatic protection (human body model)	Leakage < 1μA	2000			V

1. The leakage currents are generally very small < 1 nA. The values given here are maximum after an electrostatic stress on the pin.

4.2 DC electrical specifications (3.3 V buffers)

Operating conditions $V_{DD33} = 3.3\text{ V} \pm 0.3\text{ V}$, $T_{amb} = 25^\circ\text{ C}$ unless otherwise specified

Table 10. DC electrical characteristics

Symbol	Parameter	Test condition	Min.	Typ.	Max.	Unit
V_{IL}	Low level Input voltage				0.8	V
V_{IH}	High level Input voltage		2.0			V
V_{hyst}	Schmitt trigger hysteresis		0.4			V
V_{ol}	Low level output	$I_{ol} = 2\text{mA}$			0.15	V
V_{oh}	High level output	$I_{oh} = -2\text{mA}$	$V_{DD} - 0.15$			V

4.3 Power electrical specifications

Operating conditions $V_{DD33} = 3.3\text{ V} \pm 0.3\text{ V}$, $V_L = 3.3\text{ V}$, $V_{CC} = 30\text{ V}$, $T_{amb} = 25^\circ\text{ C}$ unless otherwise specified.

Table 11. Power electrical characteristics

Symbol	Parameter	Test conditions	Min.	Typ.	Max.	Unit
R_{dsON}	Power Pchannel/Nchannel MOSFET R_{dsON}	$I_d = 1\text{ A}$		200	270	$m\Omega$
I_{dss}	Power Pchannel/Nchannel leakage I_{dss}	$V_{CC} = 35\text{ V}$			50	μA
g_N	Power Pchannel R_{dsON} matching	$I_d = 1\text{ A}$	95			%
g_P	Power Nchannel R_{dsON} matching	$I_d = 1\text{ A}$	95			%
t_{dLs}	Low current dead time (static)	See test circuits , Figure 11 and Figure 12		10	20	ns
t_{dON}	Turn-on delay time	Resistive load			100	ns
t_{dOFF}	Turn-off delay time	Resistive load			100	ns
t_r	Rise time	Resistive load, Figure 11 and Figure 12			25	ns
t_f	Fall time	Resistive load, Figure 11 and Figure 12			25	ns
V_{CC}	Supply voltage		8		36	V
V_L	Low logical state voltage	$V_L = 3.3\text{ V}$	0.8			V
V_H	High logical state voltage	$V_L = 3.3\text{ V}$			1.7	V
$I_{VCC-PWRDN}$	Supply current from V_{CC} in PWRDN	$PWRDN = 0$			3	mA
$I_{VCC-hiz}$	Supply current from V_{CC} in 3-state	$V_{CC} = 30\text{ V}$, 3-state		22		mA

Table 11. Power electrical characteristics (continued)

Symbol	Parameter	Test conditions	Min.	Typ.	Max.	Unit
I_{VCC}	Supply current from V_{CC} in operation (both channel switching)	Input pulse width = 50% duty, switching frequency = 384 kHz, no LC filters;		80		mA
I_{out-sh}	Overcurrent protection threshold (short circuit current limit)		4	6		A
V_{UV}	Under voltage protection threshold			7		V
t_{pw-min}	Output minimum pulse width	No Load	70		150	ns
P_o	Output power	THD = 10%, $R_L = 8 \Omega$, $V_{CC} = 18 V$		20		W
P_o	Output power	THD = 1%, $R_L = 8 \Omega$, $V_{CC} = 18 V$		16		W

4.4 Timing specifications

Table 12. Timing characteristics

Symbol	Parameter	Test condition	Min.	Typ.	Max.	Unit
t_{RESET}	Hold time for RESET (pin 22)	Active low rest	100			ns
f_{VCO}	VCO free run frequency	No clock applied to XT1	18	28		MHz

Figure 11. Test circuit 1

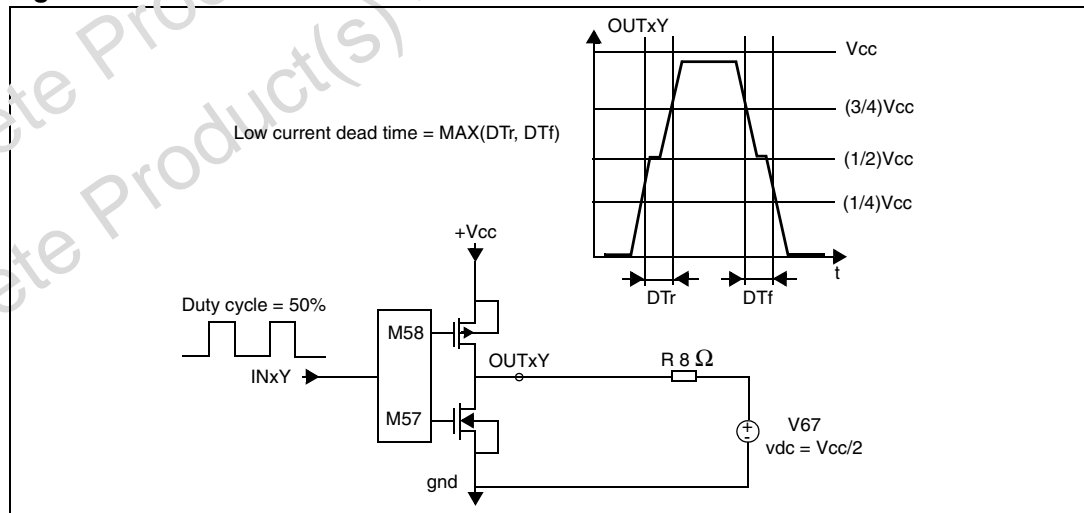
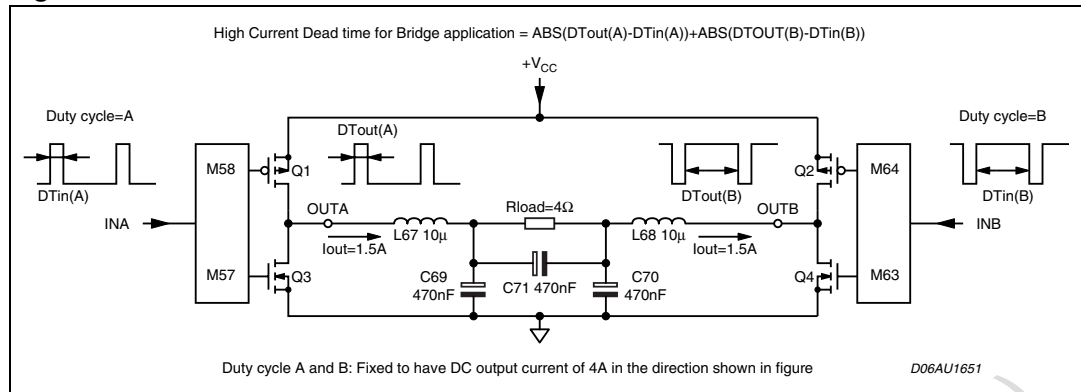

Figure 12. Test circuit 2



4.5 Power supply and control sequencing

Figure 13 shows the recommended power-up and power-down sequencing. The "time zero" reference point is taken where V_{CC} crosses the under voltage lock out threshold.

Figure 13. Recommended power up and power down sequence

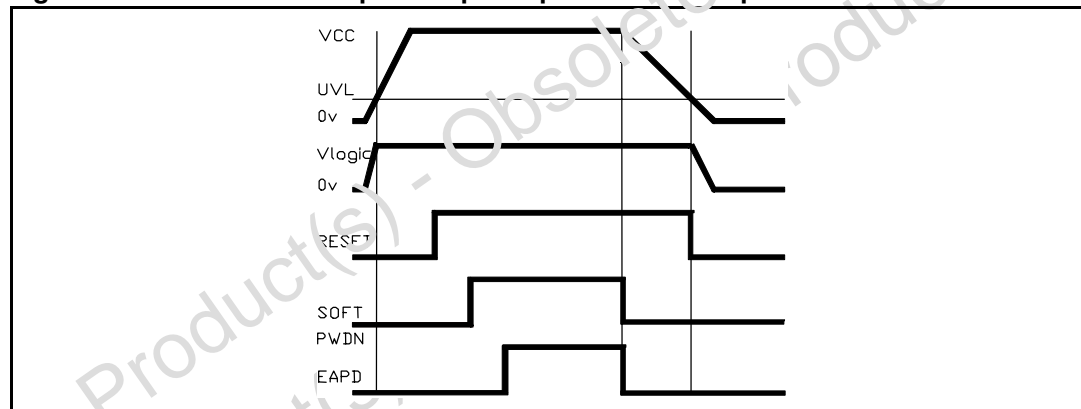

5 Electrical characteristics curves

5.1 Output power against supply voltage

Figure 14. Stereo mode - output power vs. supply voltage, THD+N = 10%

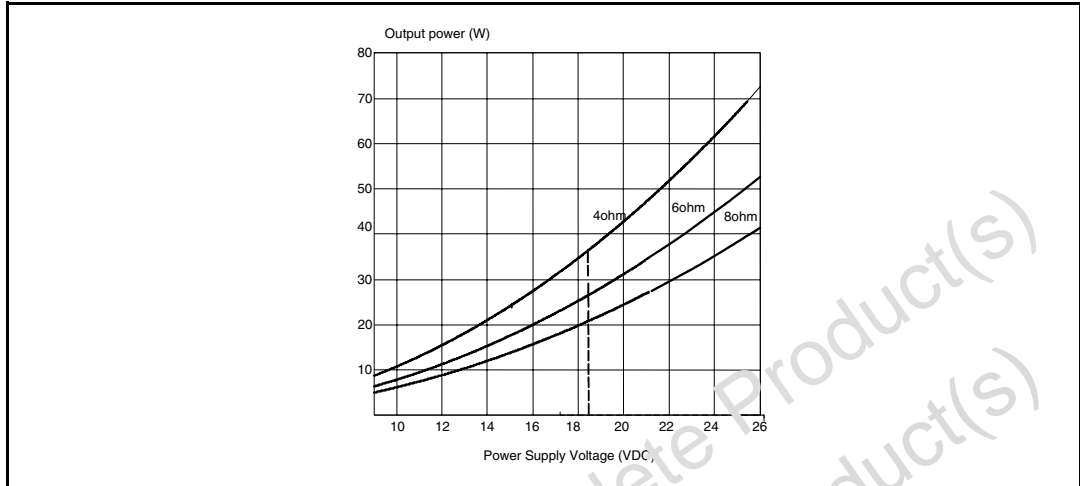

Figure 14 shows the full-scale output power (0 cBFS digital input with unity amplifier gain) as a function of power supply voltage for 4, 6, and 8 Ω loads in either DDX[®] mode or binary full bridge mode. Output power is constrained for higher impedance loads by the maximum voltage limit of the STA323WQS and by the over-current protection limit for lower impedance loads. The minimum threshold for the over-current protection circuit of the STA323WQS is 4 A (at 25° C) but the typical threshold is 6 A for the device. The solid curves shows the typical output power capability of the device. The dotted curves shows the output power capability constrained to the minimum current specification of the STA323WQS. The output power curves assume proper thermal management of the power device's internal dissipation.

Figure 15. Output power vs. supply for stereo bridge, THD+N=1%

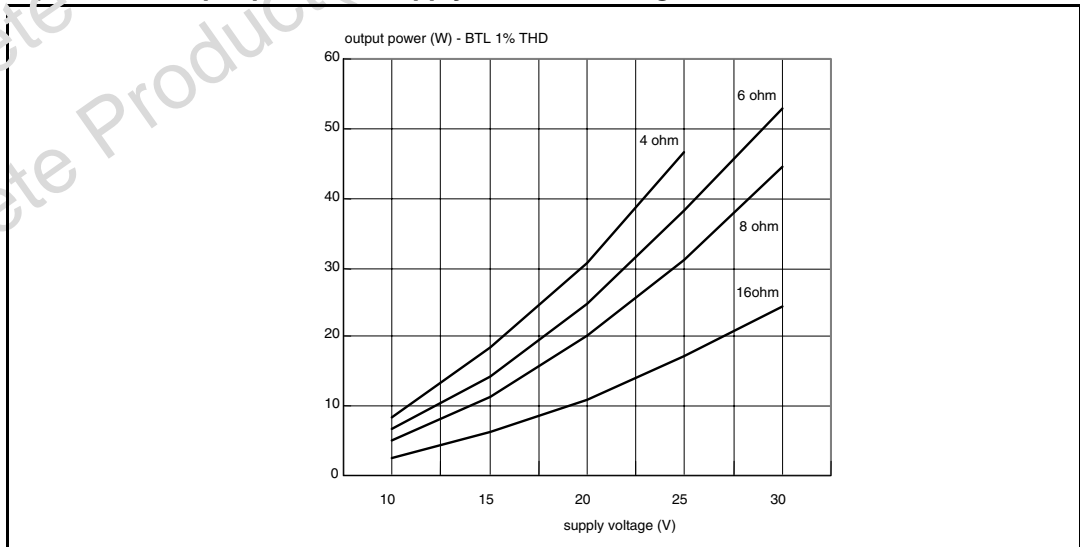

Figure 15 shows the mono mode output power as a function of power supply voltages for loads of 4, 6, 8 and 16 Ω. The same current limits as those given for Figure 14 apply, except output current is 8 A minimum, with 12 A typical in the mono-bridge configuration. The solid curves show typical performance and dashed curves depict the minimum current limit. The output power curves assume proper thermal management of the power device internal dissipation.

Figure 16. Half-bridge binary mode output power vs. supply, THD+N=10%

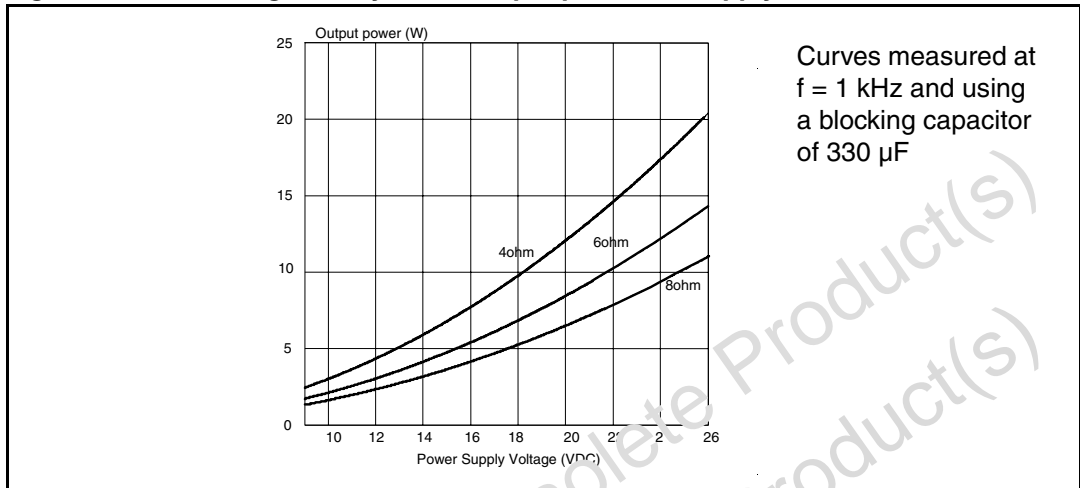
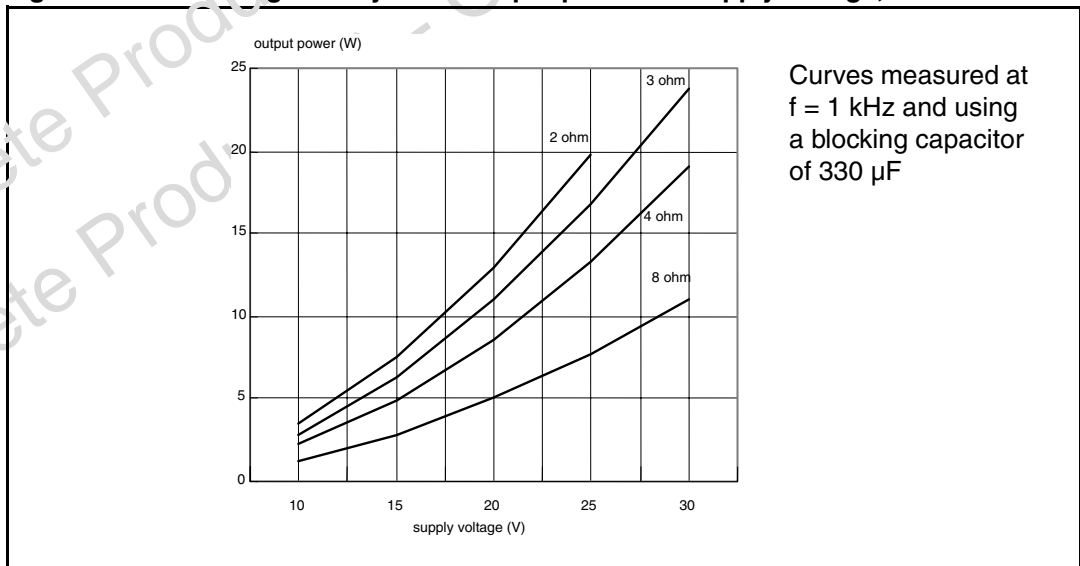

Figure 16 shows the output power as a function of power supply voltages for loads of 4, 6, and 8 Ω when the STA323WQS is operated in a half-bridge binary mode. The curves depict typical performance. Minimum current limit is not reached for these combinations of voltage and load impedance. The output power curves assume proper thermal management of the power device internal dissipation.

Figure 17. Half-bridge binary mode output power vs. supply voltage, THD+N=1%



5.2 Audio performance

5.2.1 Stereo mode, operation with $V_{CC} = 26\text{ V}$, $8\ \Omega$ load

Figure 18. Typical efficiency

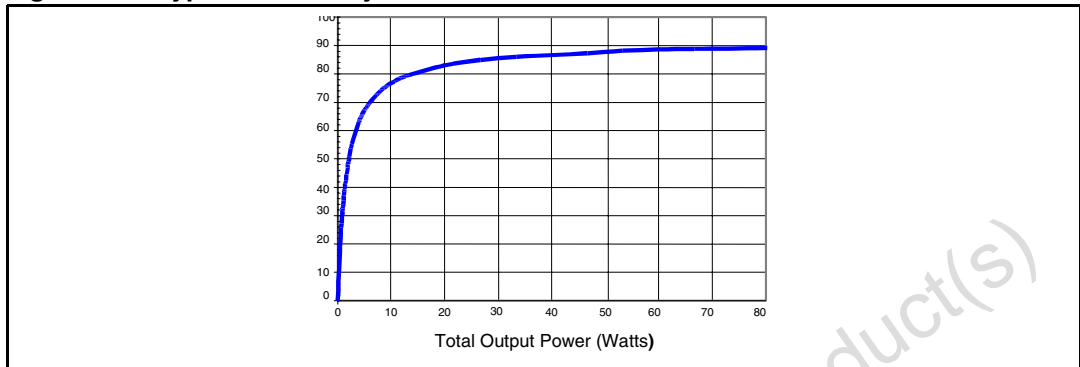

Figure 19. Typical frequency response

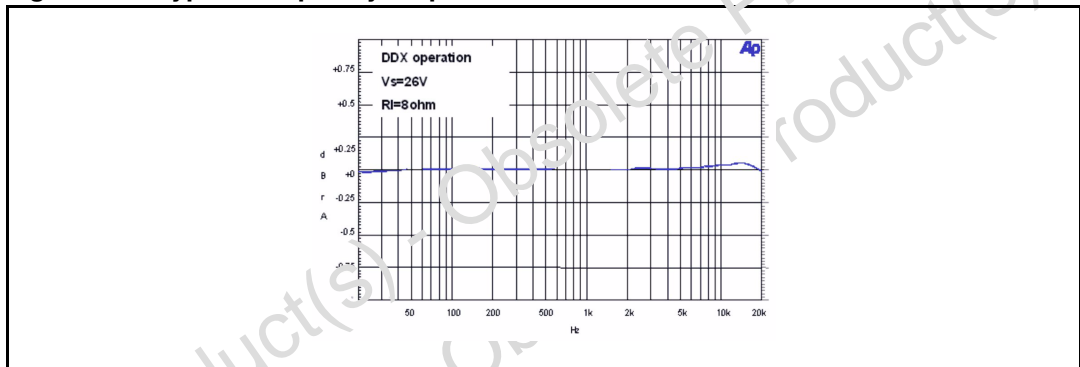

Figure 20. FFT -60 dB, 1 kHz output

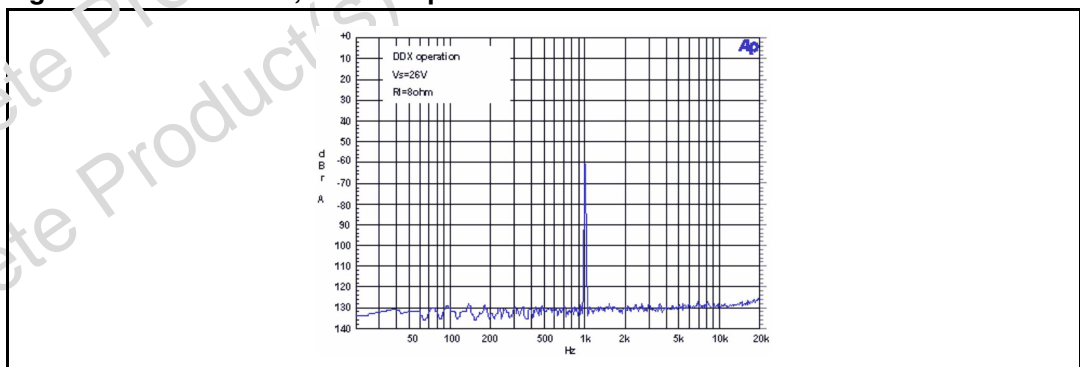
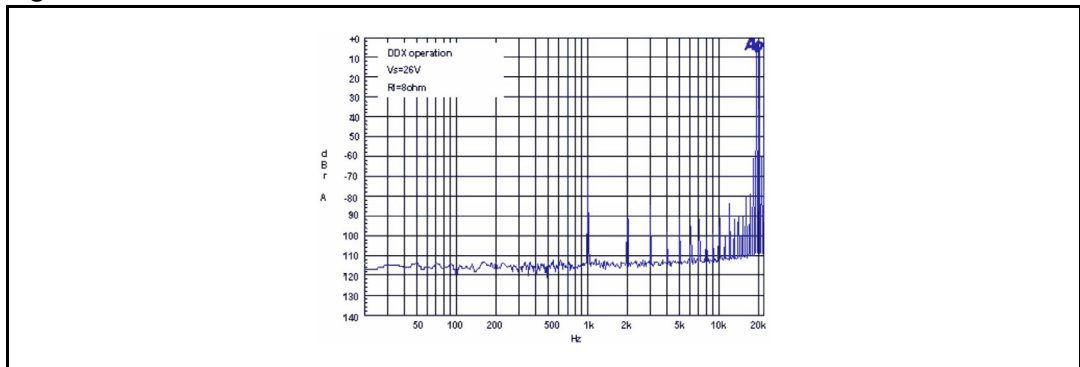

Figure 21. FFT inter-modulation distortion 19 kHz and 20 kHz



5.2.2 Stereo mode, operation with $V_{CC} = 18.5 V$

Figure 22. Frequency response, 1 W, BTL, 8 Ω

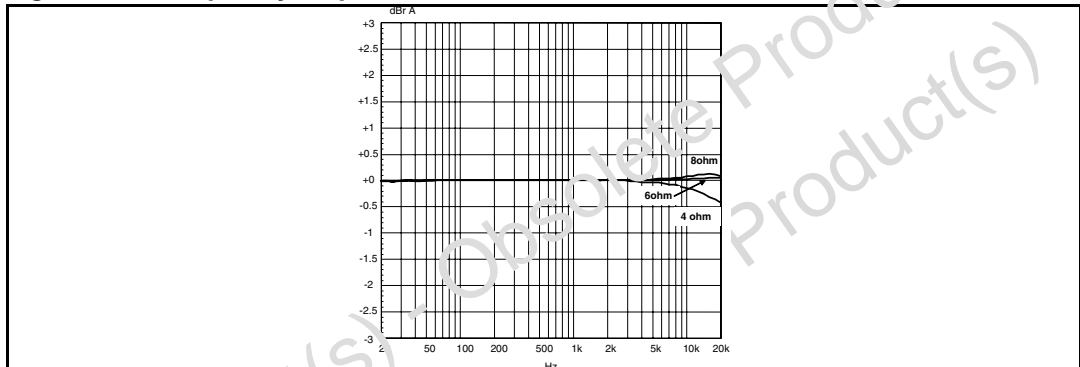

Figure 23. Channel separation, 1 W, BTL stereo mode

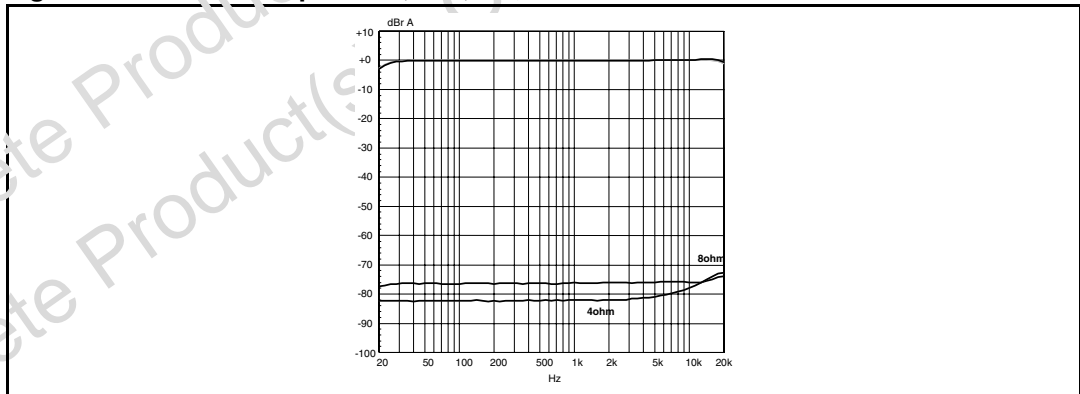

Figure 24. THD vs. output power, BTL, 1 kHz

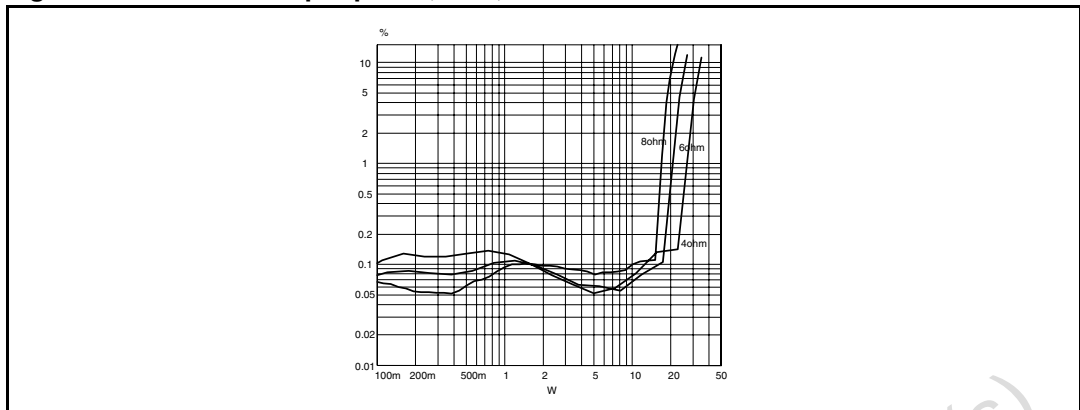

Figure 25. THD vs. frequency, 1 W output, stereo mode

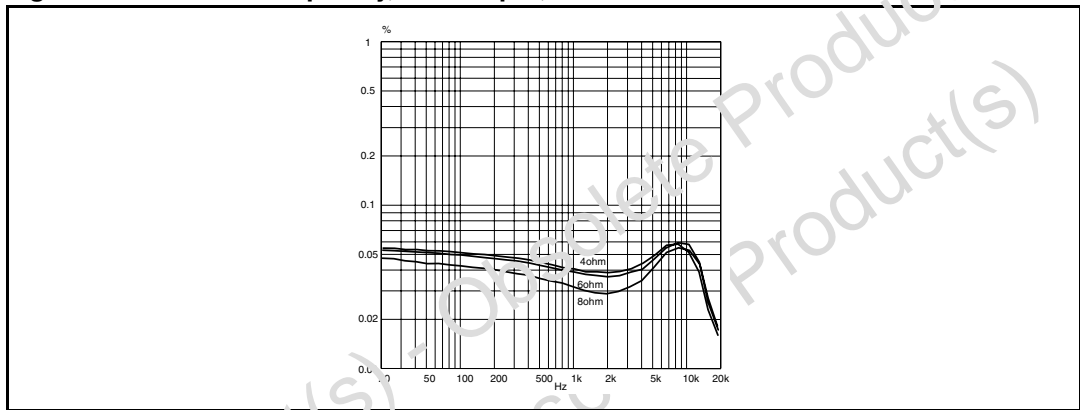

Figure 26. THD vs. frequency, BTL, 16 W output

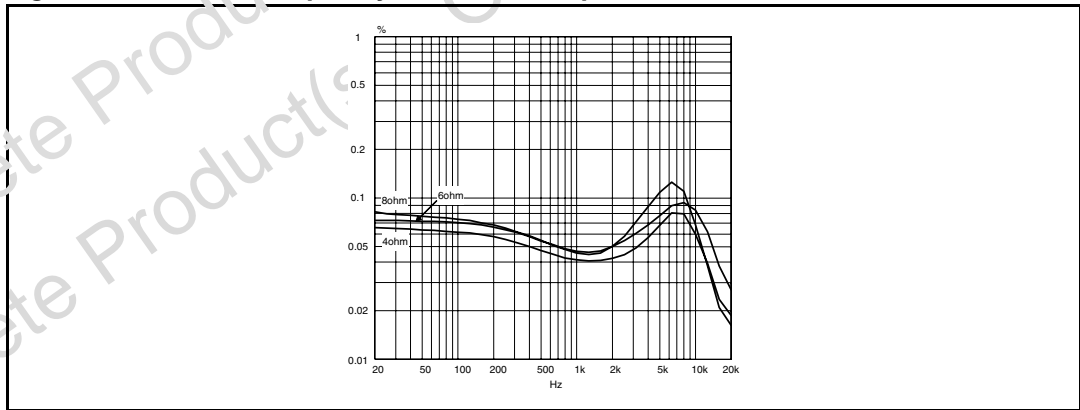

Figure 27. FFT 0 dBFS 1 kHz, 8 Ω

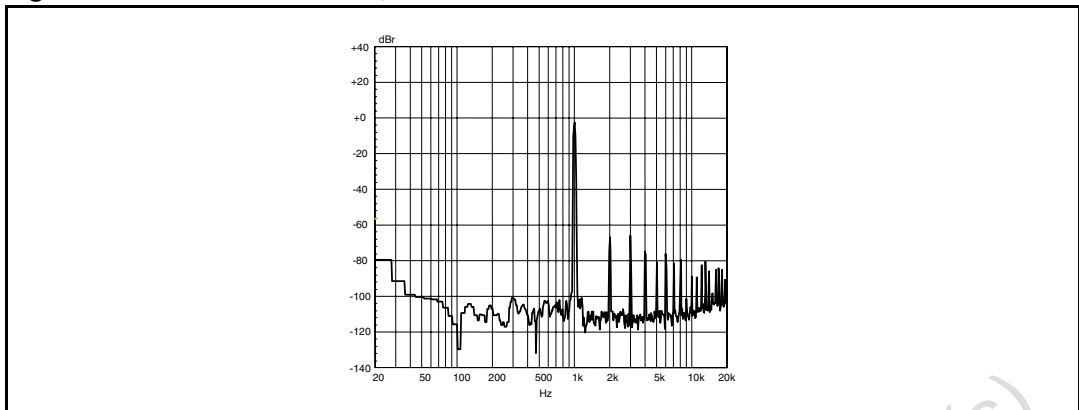

Figure 28. FFT 0 dBFS 1 kHz, 1 kHz 6 Ω

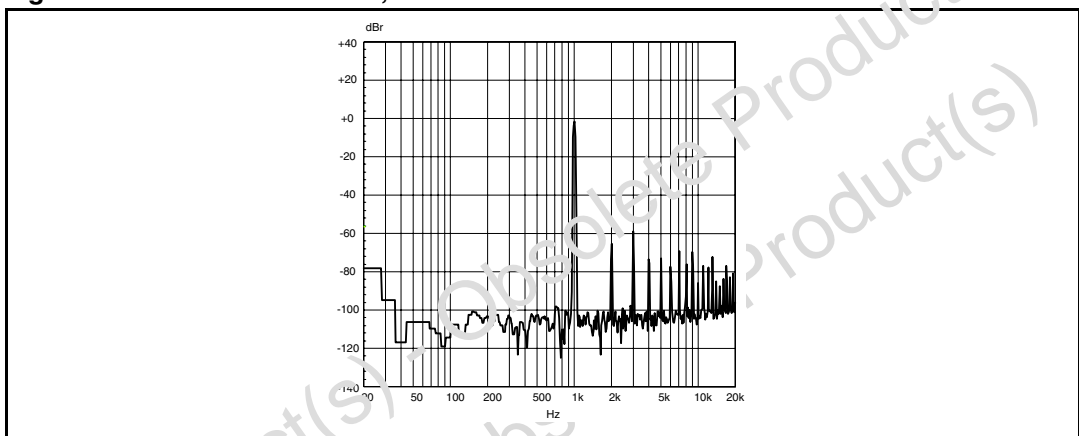

Figure 29. FFT 0 dBFS 1 kHz, 1 kHz 4 Ω

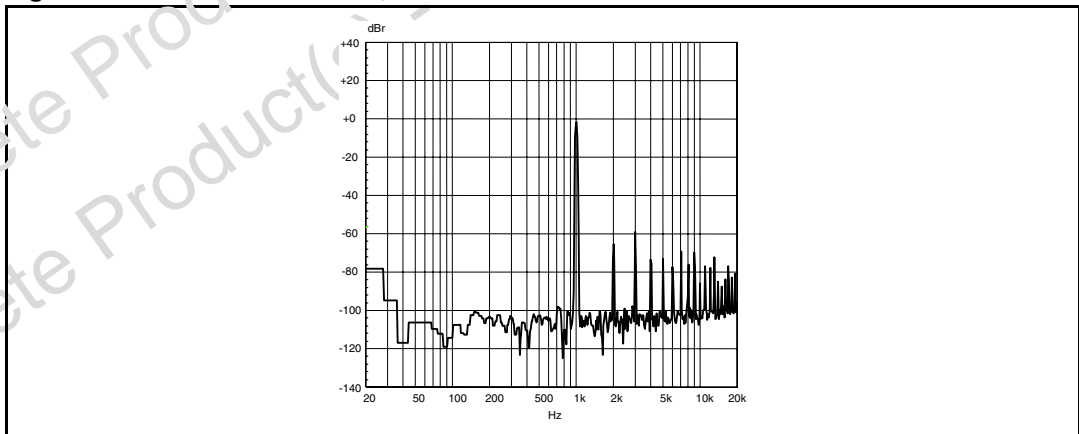

Figure 30. FFT -60 dBFS 1 kHz, 8 Ω

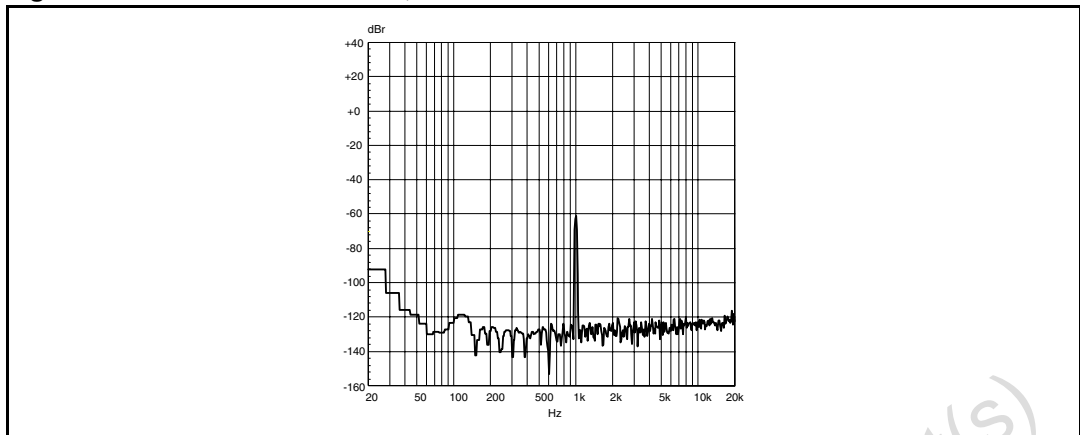

Figure 31. FFT -60 dBFS 1 kHz, 6 Ω

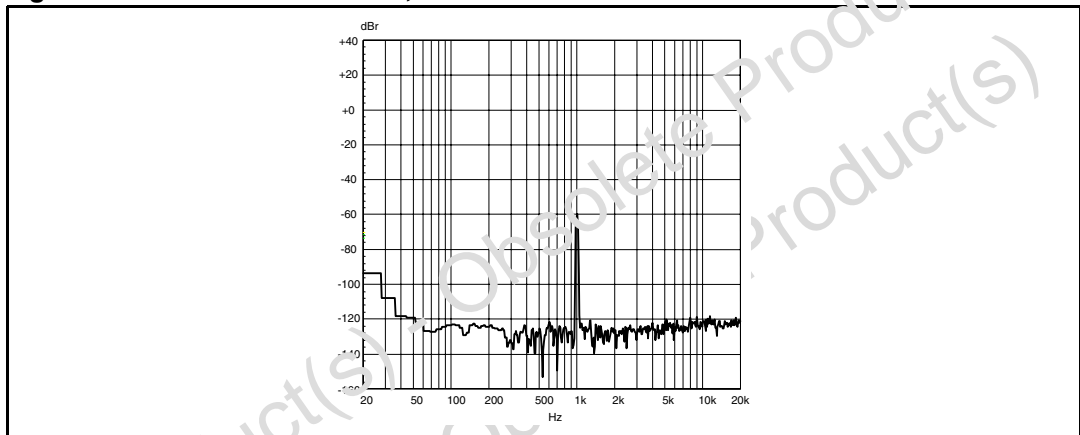

Figure 32. FFT -60 dBFS 1 kHz, 4 Ω

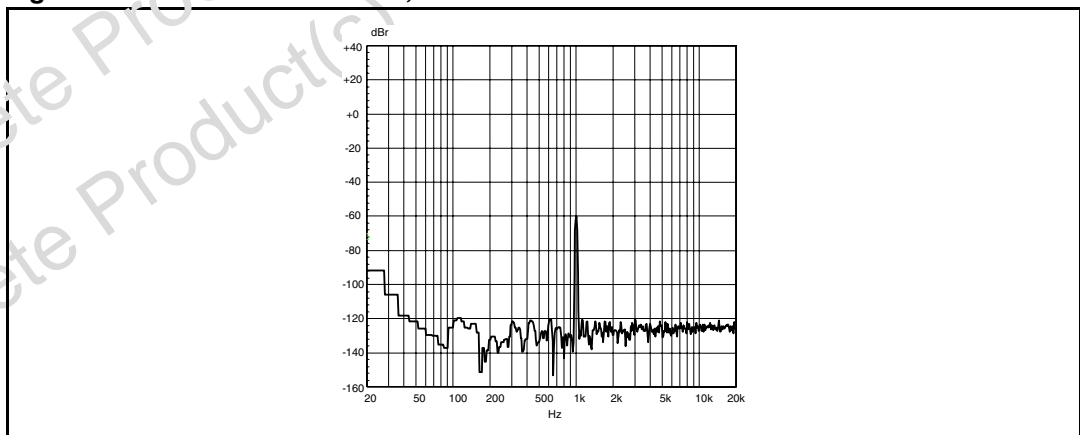
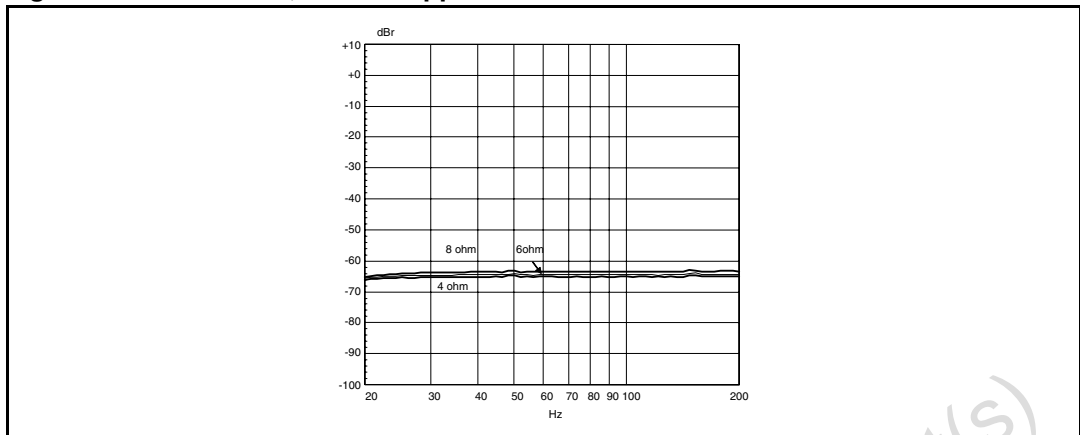

Figure 33. PSRR BTL, 500 mV ripple



5.2.3 Half-bridge binary mode, operation with Vcc = 18.5 V

Figure 34. Frequency response, 1 W, binary half-bridge mode

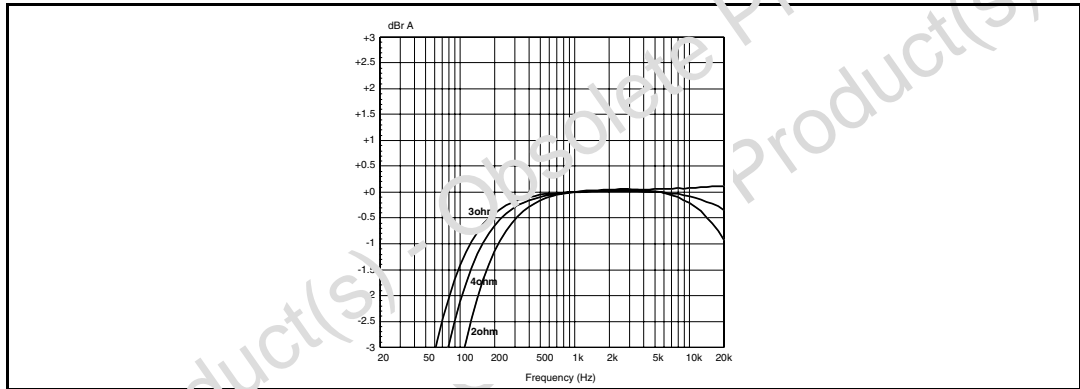

Figure 35. Channel separation, 1 W, half bridge binary

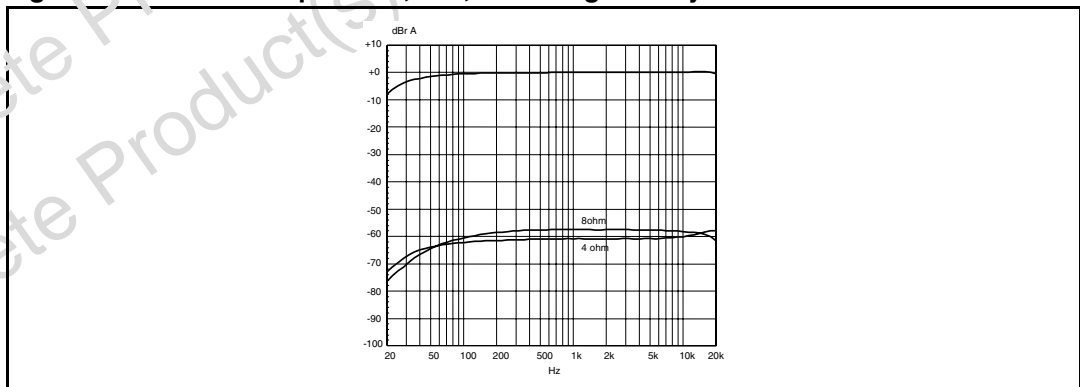

Figure 36. THD+N vs. output power, single ended, 1 kHz, half-bridge binary

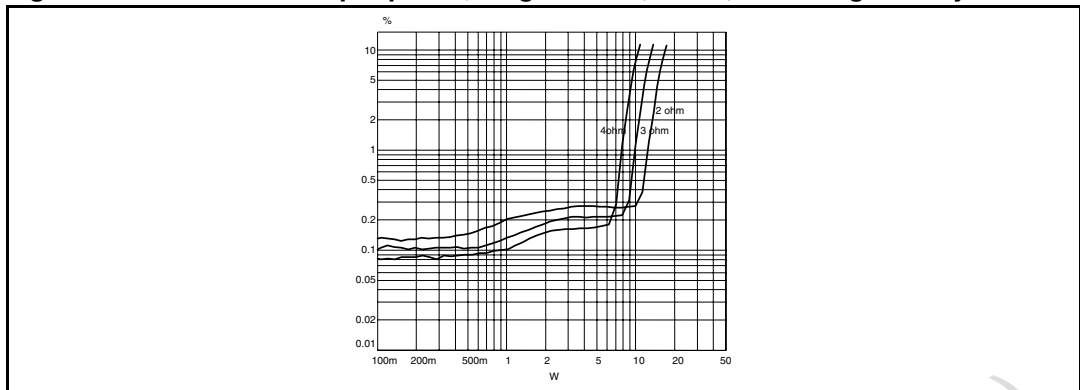

Figure 37. THD vs. frequency, single ended, 1 W

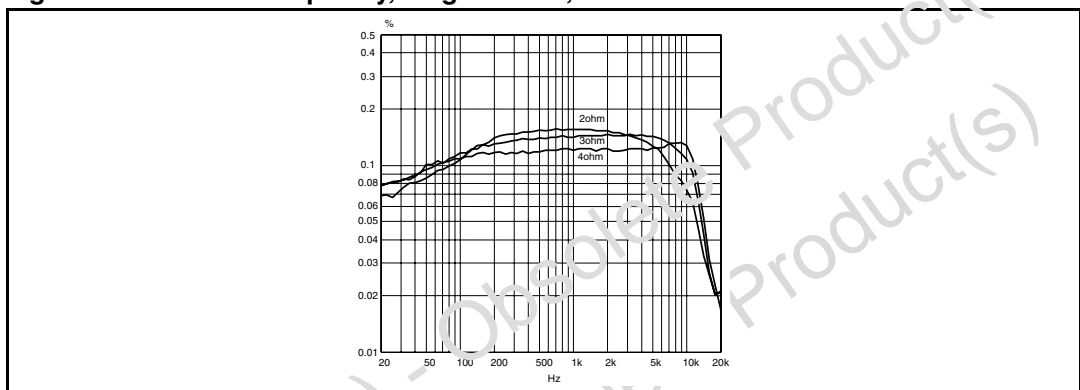

Figure 38. THD vs. frequency, single ended, 8 W

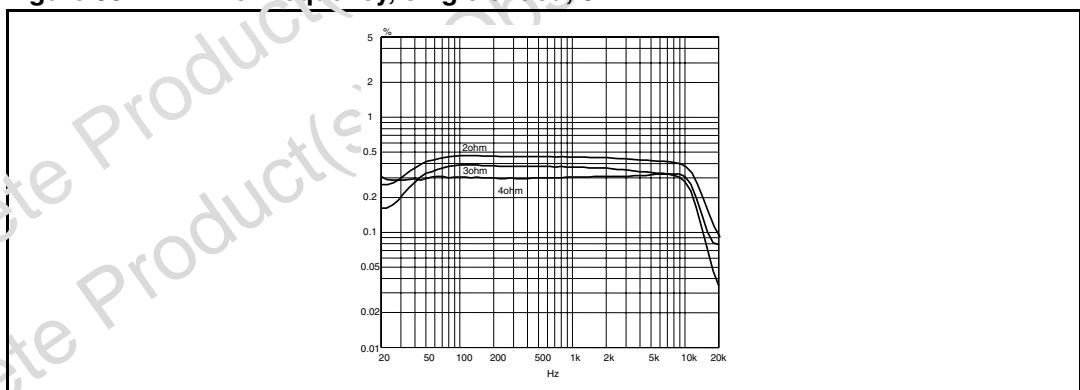

Figure 39. FFT 0 dB, 1 kHz, single ended, 2 Ω

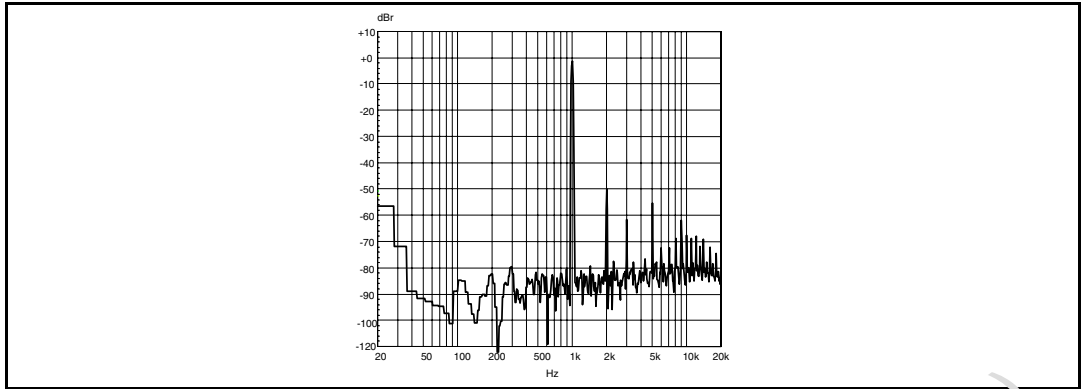

Figure 40. FFT 0 dB, 1 kHz, single ended, 3 Ω

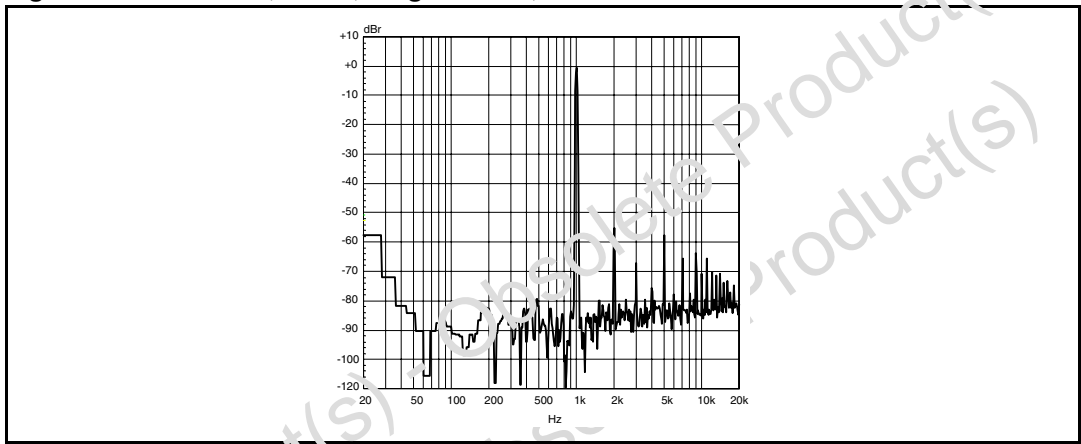

Figure 41. FFT 0 dB, 1 kHz, single ended, 4 Ω

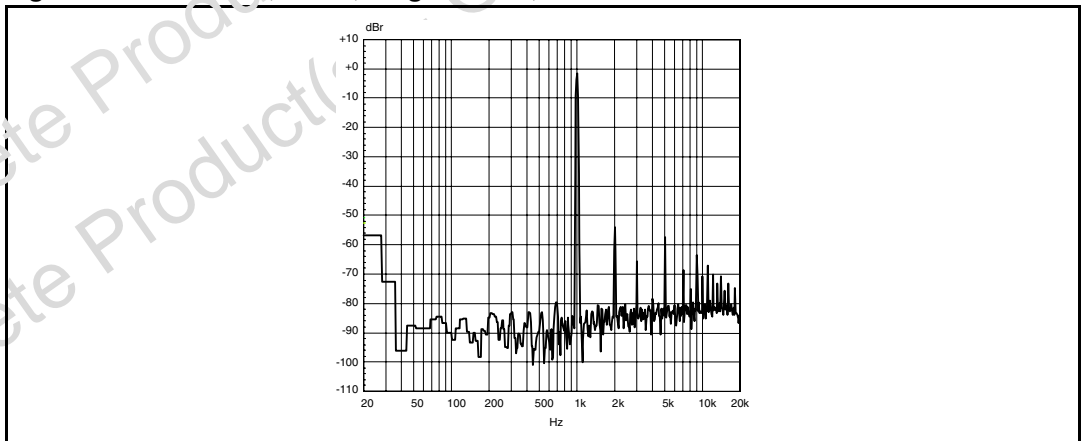

Figure 42. FFT -60 dB, single ended, 1 kHz, 2 Ω

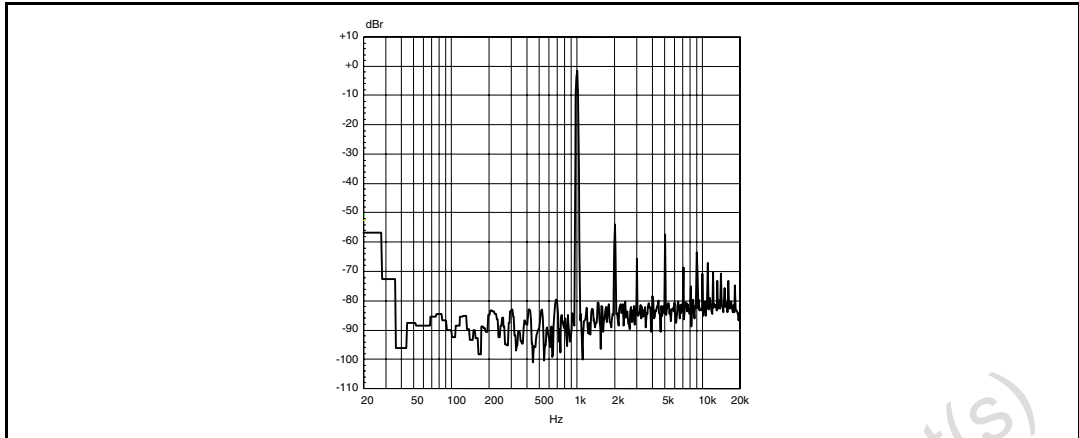

Figure 43. FFT -60 dB, single ended, 1 kHz, 4 Ω

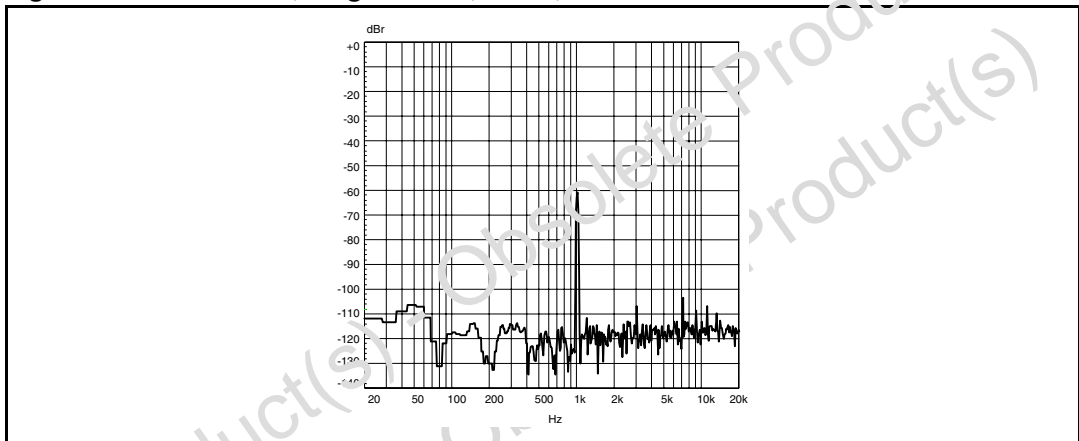

Figure 44. FFT -60 dB, single ended, 1 kHz, 3 Ω

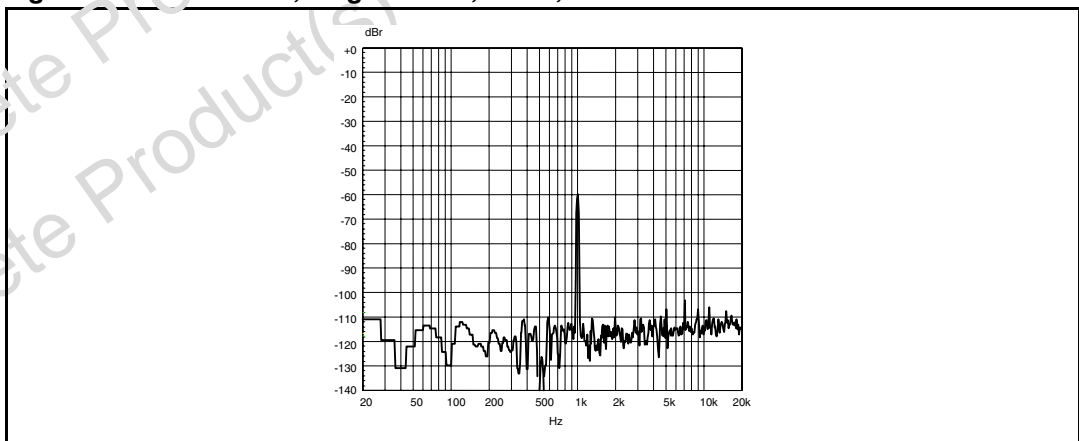
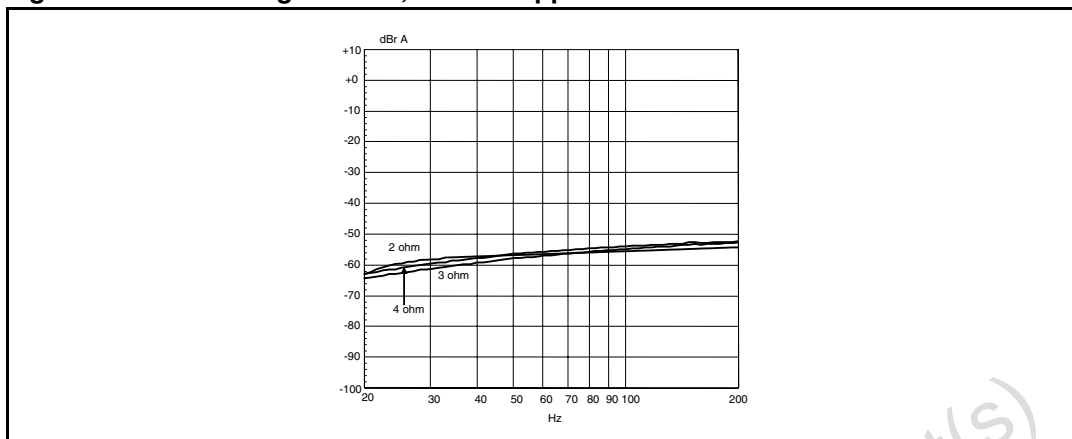

Figure 45. PSRR single ended, 500 mV ripple



Obsolete Product(s) - Obsolete Product(s)
Obsolete Product(s) - Obsolete Product(s)

6 I²C bus specification

The STA323WQS supports the I²C fast mode (400 kbit/s) protocol. This protocol defines any device that sends data on to the bus as a transmitter and any device that reads the data as a receiver. The device that controls the data transfer is known as the master and the other as the slave. The master always starts the transfer and provides the serial clock for synchronization. The STA323WQS is always a slave device in all of its communications.

6.1 Communication protocol

Data transition or change

Data changes on the SDA line must only occur when the SCL clock is low. SDA transition while the clock is high is used to identify a START or STOP condition.

Start condition

START is identified by a high to low transition of the data bus SDA signal while the clock signal SCL is stable in the high state. A START condition must precede any command for data transfer.

Stop condition

STOP is identified by a low to high transition of the data bus SDA signal while the clock signal SCL is stable in the high state. A STOP condition terminates communication between STA323WQS and the bus master.

Data input

During the data input the STA323WQS samples the SDA signal on the rising edge of clock SCL. For correct device operation the SDA signal must be stable during the rising edge of the clock and the data can change only when the SCL line is low.

6.2 Device addressing

To start communication between the master and the STA323WQS, the master must initiate with a START condition. Following this, the master sends 8 bits (MSB first) on the SDA line corresponding to the device select address and read or write mode.

The 7 MSBs are the device address identifiers, corresponding to the I²C bus definition. In the STA323WQS the I²C interface uses a device address of decimal 34 (binary 00100010).

The 8th bit (LSB) identifies read or write operation, RW. This bit is set to 1 in read mode and 0 for write mode. After a START condition the STA323WQS identifies the device address on the bus. If a match is found, it acknowledges the identification on the SDA bus during the 9th bit time. The byte following the device identification byte is the internal space address.

6.3 Write operation

Figure 46. I²C write procedure

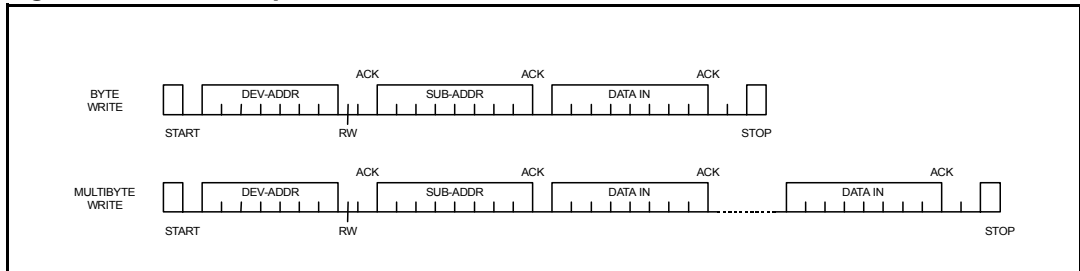

Following the START condition the master sends a device select code with the RW bit set to 0. The STA323WQS acknowledges this and then the master writes the internal address byte.

After receiving the internal byte address the STA323WQS again responds with an acknowledgement.

Byte write

In the byte write mode the master sends one data byte. This is acknowledged by the STA323WQS. The master then terminates the transfer by generating a STOP condition.

Multi-byte write

The multi-byte write modes can start from any internal address. Sequential data bytes are written to sequential addresses within the STA323WQS.

The master generates a STOP condition to terminate the transfer.

6.4 Read operation

Figure 47. I²C read procedure

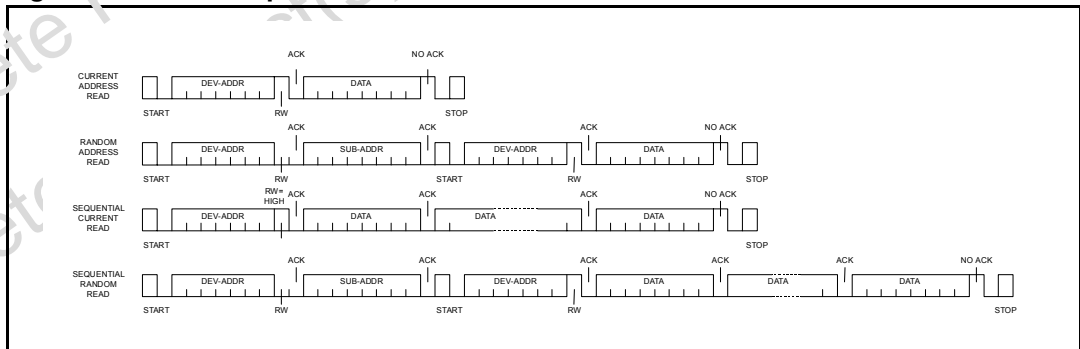

Current address byte read

Following the START condition the master sends a device select code with the RW bit set to 1. The STA323WQS acknowledges this and then responds by sending one byte of data. The master then terminates the transfer by generating a STOP condition.

Current address multi-byte read

The multi-byte read modes can start from any internal address. Sequential data bytes are read from sequential addresses within the STA323WQS. The master acknowledges each data byte read and then generates a STOP condition to terminate the transfer.

Random address byte read

Following the START condition the master sends a device select code with the RW bit set to 0. The STA323WQS acknowledges this and then the master writes the internal address byte. After receiving, the internal byte address the STA323WQS again responds with an acknowledgement. The master then initiates another START condition and sends the device select code with the RW bit set to 1. The STA323WQS acknowledges this and then responds by sending one byte of data. The master then terminates the transfer by generating a STOP condition.

Random address multi-byte read

The multi-byte read modes can start from any internal address. Sequential data bytes are then read from sequential addresses within the STA323WQS. The master acknowledges each data byte read and then generates a STOP condition to terminate the transfer.

7 Register descriptions

Table 13. Register summary

Address	Name	D7	D6	D5	D4	D3	D2	D1	D0
0x00	ConfA	FDRB	TWAB	TWRB	IR1	IR0	MCS2	MCS1	MCS0
0x01	ConfB	C2IM	C1IM	DSCKE	SAIFB	SAI3	SAI2	SAI1	SAI0
0x02	ConfC		CSZ4	CSZ3	CSZ2	CSZ1	CSZ0	OM1	OM0
0x03	ConfD	MME	ZDE	DRC	BQL	PSL	DSPB	DEMP	HPB
0x04	ConfE	SVE	ZCE	DCCV	PWMS	AME	RES	MPC	MPCV
0x05	ConfF	EAPD	PWDN	ECLE	LDTE	BCLE	IDE	OCFG1	OCFG0
0x06	Mmute								MiMute
0x07	Mvol	MV7	MV6	MV5	MV4	MV3	MV2	MV1	MV0
0x08	C1Vol	C1V7	C1V6	C1V5	C1V4	C1V3	C1V2	C1V1	C1V0
0x09	C2Vol	C2V7	C2V6	C2V5	C2V4	C2V3	C2V2	C2V1	C2V0
0x0A	C3Vol	C3V7	C3V6	C3V5	C3V4	C3V3	C3V2	C3V1	C3V0
0x0B	Auto1	AMPS		AMGC1	AMGC0	AMV1	AMV0	AMEQ1	AMEQ0
0x0C	Auto2	XO3	XO2	XO1	XO0	AMAM2	AMAM1	AMAM0	AMAME
0x0D	Auto3				PEQ4	PEQ3	PEQ2	PEQ1	PEQ0
0x0E	C1Cfg	C1OM1	C1OM0	C1LS1	C1LS0	C1BO	C1VBP	C1EQBP	C1TCB
0x0F	C2Cfg	C2OM1	C2OM0	C2LS1	C2LS0	C2BO	C2VBP	C2EQBP	C2TCB
0x10	C3Cfg	C3OM1	C3OM0	C3LS1	C3LS0	C3BO	C3VBP		
0x11	Tone	TTC3	TTC2	TTC1	TTC0	BTC3	BTC2	BTC1	BTC0
0x12	L1ar	L1A3	L1A2	L1A1	L1A0	L1R3	L1R2	L1R1	L1R0
0x13	L1atrt	L1AT3	L1AT2	L1AT1	L1AT0	L1RT3	L1RT2	L1RT1	L1RT0
0x14	L2ar	L2A3	L2A2	L2A1	L2A0	L2R3	L2R2	L2R1	L2R0
0x15	L2atrt	L2AT3	L2AT2	L2AT1	L2AT0	L2RT3	L2RT2	L2RT1	L2RT0
0x16	Cfaddr2	CFA7	CFA6	CFA5	CFA4	CFA3	CFA2	CFA1	CFA0
0x17	B1cf1	C1B23	C1B22	C1B21	C1B20	C1B19	C1B18	C1B17	C1B16
0x18	B1cf2	C1B15	C1B14	C1B13	C1B12	C1B11	C1B10	C1B9	C1B8
0x19	B1cf3	C1B7	C1B6	C1B5	C1B4	C1B3	C1B2	C1B1	C1B0
0x1A	B2cf1	C2B23	C2B22	C2B21	C2B20	C2B19	C2B18	C2B17	C2B16
0x1B	B2cf2	C2B15	C2B14	C2B13	C2B12	C2B11	C2B10	C2B9	C2B8
0x1C	B2cf3	C2B7	C2B6	C2B5	C2B4	C2B3	C2B2	C2B1	C2B0
0x1D	A1cf1	C3B23	C3B22	C3B21	C3B20	C3B19	C3B18	C3B17	C3B16
0x1E	A1cf2	C3B15	C3B14	C3B13	C3B12	C3B11	C3B10	C3B9	C3B8
0x1F	A1cf3	C3B7	C3B6	C3B5	C3B4	C3B3	C3B2	C3B1	C3B0

Table 13. Register summary (continued)

Address	Name	D7	D6	D5	D4	D3	D2	D1	D0
0x20	A2cf1	C4B23	C4B22	C4B21	C4B20	C4B19	C4B18	C4B17	C4B16
0x21	A2cf2	C4B15	C4B14	C4B13	C4B12	C4B11	C4B10	C4B9	C4B8
0x22	A2cf3	C4B7	C4B6	C4B5	C4B4	C4B3	C4B2	C4B1	C4B0
0x23	B0cf1	C5B23	C5B22	C5B21	C5B20	C5B19	C5B18	C5B17	C5B16
0x24	B0cf2	C5B15	C5B14	C5B13	C5B12	C5B11	C5B10	C5B9	C5B8
0x25	B0cf3	C5B7	C5B6	C5B5	C5B4	C5B3	C5B2	C5B1	C5B0
0x26	Cfud							WA	W1
0x27	MPCC1	MPCC15	MPCC14	MPCC13	MPCC12	MPCC11	MPCC10	MPCC9	MPCC8
0x28	MPCC2	MPCC7	MPCC6	MPCC5	MPCC4	MPCC3	MPCC2	MPCC1	MPCC0
0x29	RES	RES	RES	RES	RES	RES	RES	RES	RES
0x2A	RES	RES	RES	RES	RES	RES	RES	RES	RES
0x2B	FDRC1	FDRC15	FDRC14	FDRC13	FDRC12	FDRC11	FDRC10	FDRC9	FDRC8
0x2C	FDRC2	FDRC7	FDRC6	FDRC5	FDRC4	FDRC3	FDRC2	FDRC1	FDRC0
0x2D	Status	PLLUL						FAULT	TWARN

7.1 Configuration register A (address 0x00)

D7	D6	D5	D4	D3	D2	D1	D0
FDRB	TWAB	TWRB	IR1	IR0	MCS2	MCS1	MCS0
0		1	0	0	0	1	1

7.1.1 Master clock select

Table 14. Master clock select

Bit	R/W	RST	Name	Description
0	RW	1	MCS0	Master clock select: selects the ratio between the input I ² S sample frequency and the input clock.
1	RW	1	MCS1	
2	RW	0	MCS2	

The STA323WQS supports sample rates of 32 kHz, 44.1 kHz, 48 kHz, 88.2 kHz, and 96 kHz. Therefore the internal clock is:

- 32.768 MHz for 32 kHz
- 45.1584 MHz for 44.1 kHz, 88.2 kHz, and 176.4 kHz
- 49.152 MHz for 48 kHz, 96 kHz, and 192 kHz

The external clock frequency provided to the XTI pin must be a multiple of the input sample frequency (fs). The correlation between the input clock and the input sample rate is determined by the status of the MCSx bits and the IR (input rate) register bits. The MCSx bits determine the PLL factor generating the internal clock and the IR bit determines the oversampling ratio used internally.

Table 15. IR and MCS settings for input sample rate and clock rate

Input sample rate fs (kHz)	IR	MCS[2:0]					
		000	001	010	011	100	101
32, 44.1, 48	00	768 * fs	512 * fs	384 * fs	256 * fs	128 * fs	576 * fs
88.2, 96	01	384 * fs	256 * fs	192 * fs	128 * fs	64 * fs	x
176.4, 192	1X	384 * fs	256 * fs	192 * fs	128 * fs	64 * fs	x

7.1.2 Interpolation ratio select

Table 16. Interpolation ratio select

Bit	R/W	RST	Name	Description
4:3	RW	00	IR[1:0]	Selects internal interpolation ratio based on input I ² S sample frequency

The STA323WQS has variable interpolation (re-sampling) settings such that internal processing and DDX output rates remain consistent. The first processing block interpolates by either 2 times or 1 time (pass-through) or provides a down-sample by a factor of 2.

The IR bits determine the re-sampling ratio of this interpolation.

Table 17. IR bit settings as a function of input sample rate

Input sample rate fs (kHz)	IR[1, 0]	1 st stage interpolation ratio
32	00	2 times over-sampling
44.1	00	2 times over-sampling
48	00	2 times over-sampling
88.2	01	Pass-Through
96	01	Pass-Through
176.4	10	Down-sampling by 2
192	10	Down-sampling by 2

7.1.3 Thermal warning recovery bypass

Table 18. Thermal warning recovery bypass

Bit	R/W	RST	Name	Description
5	RW	1	TWRB	0: Thermal warning Recovery enabled 1: Thermal warning Recovery disabled

If the thermal warning adjustment is enabled (TWAB = 0), then the thermal warning recovery determines if the adjustment is removed when thermal warning is negative. If TWRB = 0 and TWAB = 0, then, when a thermal warning disappears, the gain adjustment determined by the thermal warning post-scale (default = -3 dB) is removed and the gain is applied to the system. If TWRB = 1 and TWAB = 0, then when a thermal warning disappears, the thermal warning post-scale gain adjustment remains until TWRB is changed to zero or the device is reset.

7.1.4 Thermal warning adjustment bypass

Table 19. Thermal warning adjustment bypass

Bit	R/W	RST	Name	Description
6	RW	1	TWAB	0: thermal warning adjustment enabled 1: thermal warning adjustment disabled

The STA323WQS on-chip power output block provides feedback to the digital controller by the power control block inputs. The TWARN input is used to indicate a thermal warning condition. When TWARN is active (set to 0 for a period greater than 400 ms) the power control block forces an adjustment to the modulation limit in an attempt to eliminate the thermal warning condition. Once the thermal warning volume adjustment is applied, whether the gain is reapplied when TWARN is inactive, depends on the TWRB bit.

7.1.5 Fault detect recovery bypass

Table 20. Fault detect recovery bypass

Bit	R/W	RST	Name	Description
7	RW	0	FDRB	0: fault detector recovery enabled 1: fault detector recovery disabled

The DDX power block provides feedback to the digital controller using inputs to the power control block. The FAULT input is used to indicate a fault condition (either over-current or thermal). When FAULT is active (set to 0), the power control block attempts a recovery from the fault by activating the 3-state output (setting it to 0 which directs the power output block to begin recovery). It holds it at 0 for period of time in the range of 0.1 ms to 1 second as defined by the Fault-Detect Recovery Constant register (FDRC registers 29-2Ah), then toggles it back to 1. This sequence is repeated as long as the fault indication exists. This feature is enabled by default but can be bypassed by setting the FDRB control bit to 1.

Table 22. Supported serial audio input formats

BICKI	SAI[3:0]	SAIFB	Interface format
32 * fs	1100	X	I ² S 15-bit data
	1110	X	Left/right-justified 16-bit data
48 * fs	0100	X	I ² S 23-bit data
	0100	X	I ² S 20-bit data
	1000	X	I ² S 18-bit data
	0100	0	MSB first I ² S 16-bit data
	1100	1	LSB first I ² S 16-bit data
	0001	X	Left-justified 24-bit data
64 * fs	0101	X	Left-justified 20-bit data
	1001	X	Left-justified 18-bit data
	1101	X	Left-justified 16-bit data
	0010	X	Right-justified 24-bit data
	0110	X	Right-justified 20-bit data
	1010	X	Right-justified 18-bit data
	1110	X	Right-justified 16-bit data
	0000	X	I ² S 24-bit data
	0100	X	I ² S 20-bit data
	1000	X	I ² S 18-bit data
64 * fs	0000	0	MSB first I ² S 16-bit data
	1100	1	LSB first I ² S 16-bit data
	0001	X	Left-justified 24-bit data
	0101	X	Left-justified 20-bit data
	1001	X	Left-justified 18-bit data
	1101	X	Left-justified 16-bit data
	0010	X	Right-justified 24-bit data
	0110	X	Right-justified 20-bit data
	1010	X	Right-justified 18-bit data
	1110	X	Right-justified 16-bit data

For example, SAI = 1110 and SAIFB = 1 specifies right justified 16-bit data, LSB first.

Table 23. Serial input data timing characteristics (fs = 32 to 192 kHz)

parameter	Timing
BICKI frequency (slave mode)	12.5 MHz max.
BICKI pulse width high (T1) (slave mode)	40 ns min.
BICKI active to LRCKI edge delay (T2)	20 ns min.
BICKI active to LRCKI edge delay (T3)	20 ns min.
SDI valid to BICKI active setup (T4)	20 ns min.
BICKI active to SDI hold time (T5)	20 ns min.

Figure 49. Serial input and data timing

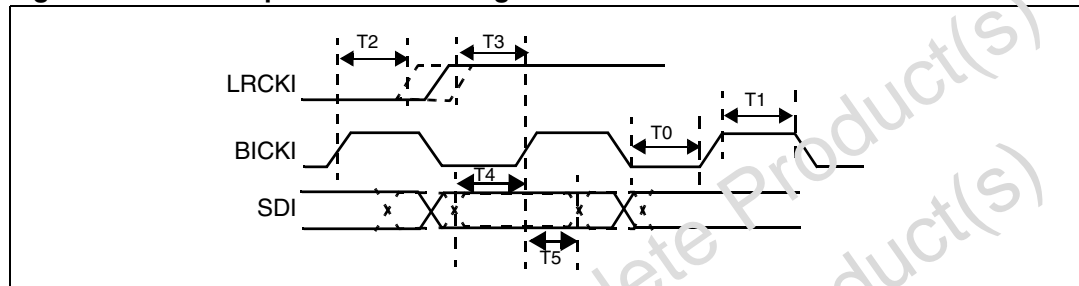

7.2.3 Delay serial clock enable

Table 24. Delay serial clock enable

Bit	R/W	RST	Name	Description
5	RW	0	DSCKE	0: no serial clock delay 1: serial clock delay by 1 core clock cycle to tolerate anomalies in some I ² S master devices

Table 25. Channel input mapping

Bit	R/W	RST	Name	Description
6	RW	0	C1IM	0: processing channel 1 receives left I ² S input 1: processing channel 1 receives right I ² S input
7	RW	1	C2IM	0: processing channel 2 receives left I ² S input 1: processing channel 2 receives right I ² S input

Each channel received from the I²S can be mapped to any internal processing channel via the channel input mapping registers. This allows processing flexibility. The default settings of these registers map each I²S input channel to its corresponding processing channel.

7.3 Configuration register C (address 0x02)

D7	D6	D5	D4	D3	D2	D1	D0
	CSZ4	CSZ3	CSZ2	CSZ1	CSZ0	OM1	OM0
	1	0	0	0	0	1	0

7.3.1 DDX[®] power-output mode

Table 26. DDX[®] power-output mode

Bit	R/W	RST	Name	Description
1:0	RW	10	OM[1:0]	Selects configuration of DDX [®] output.

The DDX[®] power output mode selects how the DDX[®] output timing is configured. Different power devices can use different output modes. The recommended use is OM = 10. When OM = 11 the CSZ bits determine the size of the DDX[®] compensating pulse.

Table 27. DDX[®] output modes

OM[1,0]	Output stage - mode
00	Not used
01	Not used
10	Recommended
11	Variable compensation

7.3.2 DDX[®] variable compensating pulse size

The DDX[®] variable compensating pulse size is intended to adapt to different power stage ICs. Contact ST for support when using this function.

Table 28. DDX[®] compensating pulse

CSZ[4:0]	Compensating pulse size
00000	0 clock period compensating pulse size
00001	1 clock period compensating pulse size
...	...
10000	16 clock period compensating pulse size
...	...
11111	31 clock period compensating pulse size

7.4 Configuration register D (address 0x03)

D7	D6	D5	D4	D3	D2	D1	D0
MME	ZDE	DRC	BQL	PSL	DSPB	DEMP	HPB
0	0	0	0	0	0	0	0

7.4.1 High-pass filter bypass

Table 29. High-pass filter bypass

Bit	R/W	RST	Name	Description
0	RW	0	HPB	0: AC coupling high pass filter enabled 1: AC coupling high pass filter enabled

The STA323WQS features an internal digital high-pass filter for DC blocking. The purpose of this filter is to prevent DC signals from passing through a DDX® amplifier. DC signals can cause speaker damage.

7.4.2 De-emphasis

Table 30. De-emphasis

Bit	R/W	RST	Name	Description
1	RW	0	DEMP	0: no de-emphasis 1: de-emphasis

By setting this bit to 1, de-emphasis is implemented on all channels. DSPB (DSP Bypass, Bit D2, CFA) bit must be set to 0 for de-emphasis to function.

7.4.3 DSP bypass

Table 31. DSP bypass

Bit	R/W	RST	Name	Description
2	RW	0	DSPB	0: normal operation 1: bypass of EQ and mixing functionality

Setting the DSPB bit bypasses all the EQ and mixing functionality of the STA323WQS core.

7.4.4 Post-scale link

Table 32. Post-scale link

Bit	R/W	RST	Name	Description
3	RW	0	PSL	0: each channel uses individual post-scale value 1: each channel uses channel 1 post-scale value

Post-scale functionality is an attenuation placed after the volume control and directly before the conversion to PWM. Post-scale can also be used to limit the maximum modulation index and therefore the peak current. Setting 1, in the PSL register, causes the value stored in Channel 1 post-scale to be used for all three internal channels.

7.4.5 Biquad coefficient link

Table 33. Biquad coefficient link

Bit	R/W	RST	Name	Description
4	RW	0	BQL	0: each channel uses coefficient values 1: each channel uses channel 1 coefficient values

For ease of use, all channels can use the biquad coefficients loaded into the channel 1 coefficient RAM space by setting the BQL bit to 1. Therefore, any EQ updates only have to be performed once.

7.4.6 Dynamic range compression/anti-clipping bit

Table 34. Dynamic range compression/anti-clipping bit

Bit	R/W	RST	Name	Description
5	RW	0	DRC	0: limiters act in anti-clipping mode 1: limiters act in dynamic range compression mode

Both limiters can be used in one of two ways: anti-clipping or dynamic range compression. When used in anti-clipping mode the limiter threshold values are constant and dependent on the limiter settings. In dynamic range compression mode the limiter threshold values vary with the volume settings allowing a nighttime listening mode that provides a reduction in the dynamic range regardless of the volume level.

7.4.7 Zero-detect mute enable

Table 35. Zero-detect mute enable

Bit	R/W	RST	Name	Description
6	RW	1	ZDE	Setting of 1 enables the automatic zero-detect mute

Setting the ZDE bit enables the zero-detect automatic mute. When ZDE = 1, the zero-detect circuit looks at the input data to each processing channel after the channel-mapping block. If any channel receives 2048 consecutive zero value samples (regardless of fs) then that individual channel is muted if this function is enabled.

7.5 Configuration register E (address 0x04)

D7	D6	D5	D4	D3	D2	D1	D0
SVE	ZCE	RES	PWMS	AME	RES	MPC	MPCV
0	0	0	0	0	0	0	0

7.5.1 Max power correction variable

Table 36. Max power correction variable

Bit	R/W	RST	Name	Description
0	RW	0	MPCV	0: use standard MPC coefficient 1: use MPCC bits for MPC coefficient

By enabling MPC and setting MPCV = 1, the max power correction becomes variable. By adjusting the MPCC registers (address 0x27-0x28) it is possible to adjust the THD at maximum unclipped power to a lower value for a particular application.

7.5.2 Max power correction

Table 37. Max power correction

Bit	R/W	RST	Name	Description
7	RW	1	MPC	0: MPC disabled 1: MPC enabled

Setting the MPC bit corrects the power device at high power. This mode lowers the THD+N of the full DDX[®] system at, and slightly below, maximum power output.

7.5.3 AM mode enable

Table 38. AM mode enable

Bit	R/W	RST	Name	Description
3	RW	0	AME	0: normal DDX [®] operation 1: AM reduction mode DDX [®] operation

The STA323WQS features a DDX[®] processing mode that minimizes the amount of noise generated in the frequency range of AM radio. This mode is intended for use when DDX[®] is operating in a device with an active AM tuner. The SNR of the DDX[®] processing is reduced to ~83 dB in this mode, which is still greater than the SNR of AM radio.

7.5.4 PWM speed mode

Table 39. PWM speed mode

Bit	R/W	RST	Name	Description
4	RW	0	PWMS	Normal or odd

Table 40. PWM output speed selections

PWMS[1:0]	PWM output speed
0	Normal speed (384kHz) all channels
1	Odd speed (341.3kHz) all channels

7.5.5 Zero-crossing volume enable

Table 41. Zero-crossing volume enable

Bit	R/W	RST	Name	Description
6	RW	1	ZCE	1: volume adjustments will only occur at digital zero-crossings 0: volume adjustments will occur immediately

The ZCE bit enables zero-crossing volume adjustments. When volume is adjusted on digital zero-crossings no clicks are audible.

7.5.6 Soft volume update enable

Table 42. Soft volume update enable

Bit	R/W	RST	Name	Description
7	RW	1	SVE	1: volume adjustments will use soft volume 0: volume adjustments will occur immediately

The STA323WQS includes a soft volume algorithm that steps through the intermediate volume values at a predetermined rate when a volume change occurs. By setting SVE = 0 this can be bypassed and volume changes will jump from the old to the new value directly. This feature is available only if individual channel volume bypass bit is set to 0.

7.6 Configuration register F (address 0x05)

D7	D6	D5	D4	D3	D2	D1	D0
EAPD	PWDN	ECLE	RES	BCLE	IDE	OCFG1	OCFG0
0	1	0	1	1	1	1	0

7.6.1 Output configuration selection

Table 43. Output configuration selection

Bit	R/W	RST	Name	Description
1:0	RW	00	OCFG[1:0]	00: 2-channel (full-bridge) power, 1-channel DDX is default

Table 44. Output configuration selections

OCFG[1:0]	Output power configuration
00	2 channel (full-bridge) power, 1 channel DDX: 1A/1B \diamond 1A/1B 2A/2B \diamond 2A/2B
01	2(half-bridge).1(full-bridge) on-board power: 1A \diamond 1A Binary 2A \diamond 1B Binary 3A/3B \diamond 2A/2B Binary
10	Reserved
11	1 channel mono-parallel: 3A \diamond 1A/1B 3B \diamond 2A/2B

Table 45. Invalid input detect mute enable

Bit	R/W	RST	Name	Description
2	RW	1	IDE	0: disabled 1: enabled

Setting the IDE bit enables this function, which looks at the input I²S data and clocking and automatically mutes all outputs if the signals are invalid.

Table 46. Binary clock loss detection enable

Bit	R/W	RST	Name	Description
5	RW	1	BCLE	0: disabled 1: enabled

Detects loss of input MCLK in binary mode and outputs 50% duty cycle to prevent audible noise when input clocking is lost.

Table 47. Auto-EAPD on clock loss enable

Bit	R/W	RST	Name	Description
7	RW	0	ECLE	0: disabled 1: enabled

When ECLE is active, it issues a power device power down signal (EAPD) on clock loss detection.

Table 48. External amplifier power down

Bit	R/W	RST	Name	Description
7	RW	0	EAPD	0: external power stage power down active 1: normal operation

EAPD is used to actively power down a connected DDX[®] power device. This register has to be written to 1 at start-up to enable the DDX[®] power device for normal operation.

7.7 Volume control

7.7.1 Master controls

Master mute register (address 0x06)

D7	D6	D5	D4	D3	D2	D1	D0
							MMUTE
							0

Master volume register (Address 0x07)

D7	D6	D5	D4	D3	D2	D1	D0
MV7	MV6	MV5	MV4	MV3	MV2	MV1	MV0
1	1	1	1	1	1	1	1

Note: The value of volume derived from MV is dependent on the AMV auto mode volume settings.

7.7.2 Channel controls

Channel 1 volume (address 0x08)

D7	D6	D5	D4	D3	D2	D1	D0
C1V7	C1V6	C1V5	C1V4	C1V3	C1V2	C1V1	C1V0
0	1	1	0	0	0	0	0

Channel 2 volume (address 0x09)

D7	D6	D5	D4	D3	D2	D1	D0
C2V7	C2V6	C2V5	C2V4	C2V3	C2V2	C2V1	C2V0
0	1	1	0	0	0	0	0

Channel 3 volume (address 0x0A)

D7	D6	D5	D4	D3	D2	D1	D0
C3V7	C3V6	C3V5	C3V4	C3V3	C3V2	C3V1	C3V0
0	1	1	0	0	0	0	0

7.7.3 Volume description

The volume structure of the STA323WQS consists of individual volume registers for each of the three channels and a master volume register, and individual channel volume trim registers. The channel volume settings are normally used to set the maximum allowable digital gain and to hard-set gain differences between certain channels. These values are normally set at the initialization of the IC and not changed. The individual channel volumes are adjustable in 0.5-dB steps from +48 dB to -80 dB. The master volume control is normally mapped to the master volume of the system. The values of these two settings are summed to find the actual gain or volume value for any given channel.

When set to 1, the Master Mute will mute all channels, whereas the individual channel mutes (CxM) will mute only that channel. Both the Master Mute and the Channel Mutes

provide a “soft mute”, that is, a gradual muting with the volume ramping down to mute in 4096 samples from the maximum volume setting at the internal processing rate of circa 96 kHz. A “hard mute” can be obtained by setting a value of 0xFF in any channel volume register or the master volume register. When volume offsets are provided, via the master volume register, any channel whose total volume is less than -100 dB is muted.

All changes in volume take place at zero-crossings when ZCE = 1 (configuration register E) on a per channel basis as this creates the smoothest possible volume transitions. When ZCE = 0, volume updates occur immediately.

The STA323WQS also features a soft-volume update function. When SVE = 1 (in configuration register E) the volume ramps between intermediate values when the value is updated. This feature can be disabled by setting SVE = 0.

Each channel also contains an individual channel volume bypass. If a particular channel has volume bypassed via the CxVBP = 1 register then only the channel volume setting for that particular channel affects the volume setting, the master volume setting does not affect that channel. Also, master soft-mute does not affect the channel if CxVBP = 1.

Each channel also contains a channel mute. If CxM = 1 a soft mute is performed on that channel.

Table 49. Master volume offset as a function of MV[7:0]

MV[7:0]	Volume offset from channel value
00000000 (0x00)	0 dB
00000001 (0x01)	-0.5 dB
00000010 (0x02)	-1 dB
...	...
01001100 (0x4C)	-38 dB
...	...
11111110 (0xFE)	-127 dB
11111111 (0xFF)	Hard Master Mute

Table 50. Channel volume as a function of CxV[7:0]

CxV[7:0]	volume
00000000 (0x00)	+48 dB
00000001 (0x01)	+47.5 dB
00000010 (0x02)	+47 dB
...	...
01100001 (0x5F)	+0.5 dB
01100000 (0x60)	0 dB
01011111 (0x61)	-0.5 dB
...	...
11111110 (0xFE)	-79.5 dB
11111111 (0xFF)	Hard channel mute

7.8 AutoMode registers

7.8.1 AutoModes EQ, volume, GC (address 0x0B)

D7	D6	D5	D4	D3	D2	D1	D0
AMPS		AMGC1	AMGC0	AMV1	AMV0	AMEQ1	AMEQ0
1		0	0	0	0	0	0

Table 51. Automode EQ

AMEQ[1,0]	Mode (Biquad 1-4)
00	User Programmable
01	Preset EQ - PEQ bits
10	Auto Volume Controlled Loudness Curve
11	Not used

Setting AMEQ to any value, other than 00, enables automode EQ. When set, biquads 1-4 are not user programmable. Any coefficient settings for these biquads is ignored. Also when automode EQ is used the pre-scale value for channels 1 and 2 becomes hard-set to -18 dB.

Table 52. Automode volume

AMV[1,0]	Mode (MVOL)
00	MVOL 0.5 to 3 256 steps (standard)
01	MVOL auto curve 30 steps
10	MVOL auto curve 40 steps
11	MVOL auto curve 50 steps

Table 53. Automode gain compression/limiters

AMGC[1:0]	Mode
00	User programmable GC
01	AC no clipping
10	AC limited clipping (10%)
11	DRC night time listening mode

Table 54. AMPS - automode auto pre scale

Bit	R/W	RST	Name	Description
0	RW	0	AMPS	Auto Mode Pre-Scale 0: -18 dB used for pre-scale when AMEQ neq 00 1: User defined pre-scale when AMEQ neq 00

7.8.2 AutoMode AM/pre-scale/bass management scale (address 0x0C)

D7	D6	D5	D4	D3	D2	D1	D0
XO3	XO2	XO1	XO0	AMAM2	AMAM1	AMAM0	AMAME
0	0	0	0	0	0	0	0

Table 55. Automode AM switching enable

Bit	R/W	RST	Name	Description
0	RW	0	AMAME	0: switching frequency determined by PWMS setting 1: switching frequency determined by AMAM settings
3:1	RW	000	AMAM[2:0]	Default: 000

Table 56. Automode AM switching frequency selection

AMAM[2:0]	48 kHz/96 kHz input fs	44.1 kHz/88.2 kHz input fs
000	0.535 MHz - 0.720 MHz	0.535 MHz - 0.670 MHz
001	0.721 MHz - 0.900 MHz	0.671 MHz - 0.800 MHz
010	0.901 MHz - 1.100 MHz	0.801 MHz - 1.000 MHz
011	1.101 MHz - 1.300 MHz	1.001 MHz - 1.180 MHz
100	1.301 MHz - 1.480 MHz	1.181 MHz - 1.340 MHz
101	1.481 MHz - 1.600 MHz	1.341 MHz - 1.500 MHz
110	1.601 MHz - 1.700 MHz	1.501 MHz - 1.700 MHz

When DDX[®] is used with an AM radio tuner, it is recommended to use the AMAM bits to automatically adjust the output PWM switching rate so that it depends on the specific radio frequency that the tuner is receiving. The values used in AMAM are also dependent upon the sample rate that is determined by the ADC used.

Table 57. Automode crossover setting

Bit	R/W	RST	Name	Description
7:4	RW	0	XO[3:0]	000: user defined crossover coefficients are used Otherwise: preset coefficients are used for the required crossover setting

Table 58. Crossover frequency selection

XO[2:0]	Bass management - crossover frequency
0000	User
0001	80 Hz
0010	100 Hz
0011	120 Hz
0100	140 Hz
0101	160 Hz
0110	180 Hz

Table 58. Crossover frequency selection (continued)

0111	200 Hz
1000	220 Hz
1001	240 Hz
1010	260 Hz
1011	280 Hz
1100	300 Hz
1101	320 Hz
1110	340 Hz
1111	360 Hz

7.8.3 Preset EQ settings (address 0x0D)

D7	D6	D5	D4	D3	D2	D1	D0
			PEQ4	PEQ3	PEQ2	PEQ1	PEQ0
			0	0	0	0	0

Table 59. Preset EQ selection

PEQ[3:0]	Setting
0000	Flat
0001	Rock
0010	Soft Rock
0011	Jazz
0100	Classical
0101	Dance
0110	Pop
00111	Soft
01000	Hard
01001	Party
01010	Vocal
01011	Hip-Hop
01100	Dialog
01101	Bass-boost #1
01110	Bass-boost #2
01111	Bass-boost #3
10000	Loudness 1 (least boost)
10001	Loudness 2
10010	Loudness 3
10011	Loudness 4

Table 59. Preset EQ selection (continued)

PEQ[3:0]	Setting
10100	Loudness 5
10101	Loudness 6
10110	Loudness 7
10111	Loudness 8
11000	Loudness 9
11001	Loudness 10
11010	Loudness 11
11011	Loudness 12
11100	Loudness 13
11101	Loudness 14
11110	Loudness 15
11111	Loudness 16 (most boost)

7.9 Channel configuration registers

7.9.1 Channel 1 configuration (address 0x0E)

D7	D6	D5	D4	D3	D2	D1	D0
C1OM1	C1OM0	C1LS1	C1LS0	C1BO	C1VBP	C1EQBP	C1TCB
0	0	0	0	0	0	0	0

7.9.2 Channel 2 configuration (address 0x0F)

D7	D6	D5	D4	D3	D2	D1	D0
C2OM1	C2OM0	C2LS1	C2LS0	C2BO	C2VBP	C2EQBP	C2TCB
0	0	0	0	0	0	0	0

7.9.3 Channel 3 configuration (address 0x10)

D7	D6	D5	D4	D3	D2	D1	D0
C3OM1	C3OM0	C3LS1	C3LS0	C3BO	C3VBP		
0	0	0	0	0	0		

EQ control can be bypassed on a per channel basis. If EQ control is bypassed on a given channel the prescale and all 9 filters (high-pass, biquads, de-emphasis, bass management cross-over, bass, treble in any combination) are bypassed for that channel.

CxEQBP:

- 0: perform EQ on channel X (normal operation)
- 1: bypass EQ on channel X

Tone control (bass and treble) can be bypassed on a per channel basis. If tone control is bypassed on a given channel the two filters that tone control utilizes are bypassed.

CxTCB:

- 0: perform tone control on channel x - (default operation)
- 1: bypass tone control on channel x

Each channel can be configured to output either the patented DDX PWM data or standard binary PWM encoded data. By setting the CxBO bit to '1', each channel can be individually set to binary operation mode.

It is also possible to map each channel independently to either of the two limiters available within the STA323WQS. In the default mode the channels are not mapped to a limiter.

Table 60. Channel Limiter Mapping Selection

CxLS[1,0]	Channel limiter mapping
00	Channel has limiting disabled
01	Channel is mapped to limiter #1
10	Channel is mapped to limiter #2

Each PWM output channel can receive data from any channel output of the volume block. Which channel a particular PWM output receives depends on the CxOM register bits for that channel.

Table 61. Channel PWM output mapping

CxOM[1:0]	PWM output from
00	Channel 1
01	Channel 2
10	Channel 3
11	Not used

7.10 Tone control (address 0x11)

D7	D6	D5	D4	D3	D2	D1	D0
TTC3	TTC2	TTC1	TTC0	BTC3	BTC2	BTC1	BTC0
0	1	1	1	0	1	1	1

Table 62. Tone control boost/cut selection

BTC[3:0]/TTC[3:0]	Boost/cut
0000	-12 dB
0001	-12 dB
...	...
0111	-4 dB
0110	-2 dB
0111	0 dB
1000	+2 dB
1001	+4 dB
...	...
1101	+12 dB
1110	+12 dB
1111	+12 dB

7.11 Dynamics control

7.11.1 Limiter 1 attack/release threshold (address 0x12)

D7	D6	D5	D4	D3	D2	D1	D0
L1A3	L1A2	L1A1	L1A0	L1R3	L1R2	L1R1	L1R0
0	1	1	0	1	0	1	0

7.11.2 Limiter 1 attack/release threshold (address 0x13)

D7	D6	D5	D4	D3	D2	D1	D0
L1AT3	L1AT2	L1AT1	L1AT0	L1RT3	L1RT2	L1RT1	L1RT0
0	1	1	0	1	0	0	1

7.11.3 Limiter 2 attack/release rate (address 0x14)

D7	D6	D5	D4	D3	D2	D1	D0
L2A3	L2A2	L2A1	L2A0	L2R3	L2R2	L2R1	L2R0
0	1	1	0	1	0	1	0

7.11.4 Limiter 2 attack/release threshold (address 0x15)

D7	D6	D5	D4	D3	D2	D1	D0
L2AT3	L2AT2	L2AT1	L2AT0	L2RT3	L2RT2	L2RT1	L2RT0
0	1	1	0	1	0	0	1

7.11.5 Dynamics control description

The STA323WQS includes two independent limiter blocks. The purpose of the limiters is to automatically reduce the dynamic range of a recording to prevent the outputs from clipping in anti-clipping mode, or to actively reduce the dynamic range for a better listening environment (such as a night-time listening mode, which is often needed for DVDs.) The two modes are selected via the DRC bit in Configuration Register D, bit 5 address 0x03. Each channel can be mapped to Limiter1 or Limiter2, or not mapped.

If a channel is not mapped, that channel will clip normally when 0 dB FS is exceeded. Each limiter will look at the present value of each channel that is mapped to it, select the maximum absolute value of all these channels, perform the limiting algorithm on that value, and then, if needed, adjust the gain of the mapped channels in unison.

The limiter attack thresholds are determined by the LxAT registers. When the Attack Threshold has been exceeded, the limiter, when active, automatically starts reducing the gain. The rate at which the gain is reduced when the attack threshold is exceeded is dependent upon the attack rate register setting for that limiter. A peak-detect algorithms used to control the gain reduction.

The release of limiter, when the gain is again increased, is dependent on an RMS-detect algorithm. The output of the volume limiter block is passed through an RMS filter. The output of this filter is compared with the release threshold, determined by the Release Threshold register.

When the RMS filter output falls below the release threshold, the gain is increased at a rate dependent upon the release rate register. The gain can never be increased past its set value and therefore the release will only occur if the limiter has already reduced the gain. The release threshold value can be used to set what is effectively a minimum dynamic range. This is helpful as over-limiting can reduce the dynamic range to virtually zero and cause program material to sound "lifeless".

In AC mode the attack and release thresholds are set relative to full-scale. In DRC mode the attack threshold is set relative to the maximum volume setting of the channels mapped to that limiter and the release threshold is set relative to the maximum volume setting plus the attack threshold.

Figure 50. Basic limiter and volume flow diagram

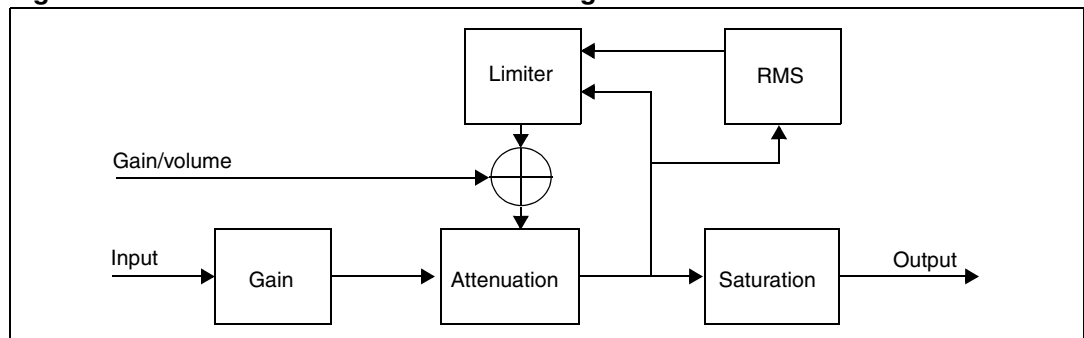

Table 63. Limiter attack rate selection

LxA[3:0]	Attack rate dB/ms	
0000	3.1584	Fast
0001	2.7072	
0010	2.2560	
0011	1.8048	
0100	1.3536	
0101	0.9024	
0110	0.4512	
0111	0.2256	
1000	0.1504	
1001	0.1123	
1010	0.0902	
1011	0.0752	
1100	0.0645	
1101	0.0564	
1110	0.0501	Slow
1111	0.0451	

Table 64. Limiter release rate selection

LxR[3:0]	Release rate dB/ms	
0000	0.5116	Fast
0001	0.1370	
0010	0.0744	
0011	0.0499	
0100	0.0360	
0101	0.0299	
0110	0.0264	
0111	0.0208	
1000	0.0198	
1001	0.0172	
1010	0.0147	
1011	0.0137	
1100	0.0134	
1101	0.0117	
1110	0.0110	Slow
1111	0.0104	

7.11.6 Anti-clipping mode

Table 65. Limiter attack - threshold selection (AC-mode)

LxAT[3:0]	AC (dB relative to FS)
0000	-12
0001	-10
0010	-8
0011	-6
0100	-4
0101	-2
0110	0
0111	+2
1000	+3
1001	+4
1010	+5
1011	+6
1100	+7
1101	+8
1110	+9
1111	+10

Table 66. Limiter release threshold selection (AC-mode)

LxRT[3:0]	AC (dB relative to FS)
0000	-∞
0001	-29dB
0010	-20dB
0011	-16dB
0100	-14dB
0101	-12dB
0110	-10dB
0111	-8dB
1000	-7dB
1001	-6dB
1010	-5dB
1011	-4dB
1100	-3dB
1101	-2dB

Table 66. Limiter release threshold selection (AC-mode) (continued)

1110	-1dB
1111	-0dB

7.11.7 Dynamic range compression mode**Table 67. Limiter attack - threshold selection (DRC-mode)**

LxAT[3:0]	DRC (dB relative to volume)
0000	-31
0001	-29
0010	-27
0011	-25
0100	-23
0101	-21
0110	-19
0111	-17
1000	-16
1001	-15
1010	-14
1011	-13
1100	-12
1101	-10
1110	-7
1111	-4

Table 68. Limiter release threshold selection (DRC-mode)

LxRT[3:0]	DRC (db relative to Volume + LxAT)
0000	$-\infty$
0001	-38 dB
0010	-36 dB
0011	-33 dB
0100	-31 dB
0101	-30 dB
0110	-28 dB
0111	-26 dB
1000	-24 dB
1001	-22 dB
1010	-20 dB
1011	-18 dB
1100	-15 dB
1101	-12 dB
1110	-9 dB
1111	-6 dB

8 User-programmable settings

8.1 EQ - biquad equation

The biquads use the equation that follows. This is shown in [Figure 51](#).

$$Y[n] = 2(b0/2)X[n] + 2(b1/2)X[n-1] + b2X[n-2] - 2(a1/2)Y[n-1] - a2Y[n-2]$$

$$= b0X[n] + b1X[n-1] + b2X[n-2] - a1Y[n-1] - a2Y[n-2]$$

where Y[n] represents the output and X[n] represents the input. Signed, fractional 28-bit multipliers are used, with coefficient values in the range of 0x800000 (-1) to 0x7FFFFF (0.9999998808).

Coefficients stored in the user defined coefficient RAM are referenced in the following manner:

- CxHy0 = b1/2
- CxHy1 = b2
- CxHy2 = -a1/2
- CxHy3 = -a2
- CxHy4 = b0/2

The x represents the channel and the y the biquad number. For example C3H41 is the b0/2 coefficient in the fourth biquad for channel 3.

Figure 51. Biquad filter

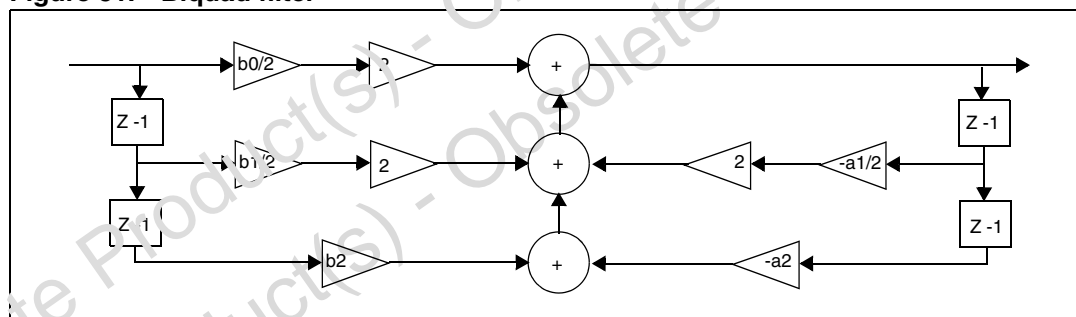

8.2 Pre-scale

The pre-scale block, which precedes the first biquad, is used for attenuation when filters are designed that boost frequencies above 0 dBFS. The Pre-Scale block is a single 28-bit signed multiplier, with 0x800000 = -1 and 0x7FFFFF = 0.9999998808. By default, all pre-scale factors are set to 0x7FFFFF.

8.3 Post-scale

The STA323WQS provides one additional multiplication after the last interpolation stage and before the distortion compensation on each channel. The post-scale block is a 24-bit signed fractional multiplier. The scale factor for this multiplier is loaded into RAM using the same I²C registers as the biquad coefficients and the mix. All channels can use the same settings as channel 1 by setting the post-scale link bit.

8.4 Mix/bass management

The STA323WQS provides one post-EQ mixing block per channel. Each channel has two mixing coefficients, which are each 24-bit signed fractional multipliers, that correspond to the two channels of input to the mixing block. These coefficients are accessible via the User Controlled Coefficient RAM described below. The mix coefficients expressed as 24-bit signed, fractional numbers in the range +1.0 (8388607) to -1.0 (-8388608), are used to provide three channels of output from two channels of filtered input.

Figure 52. Mix/bass management block diagram

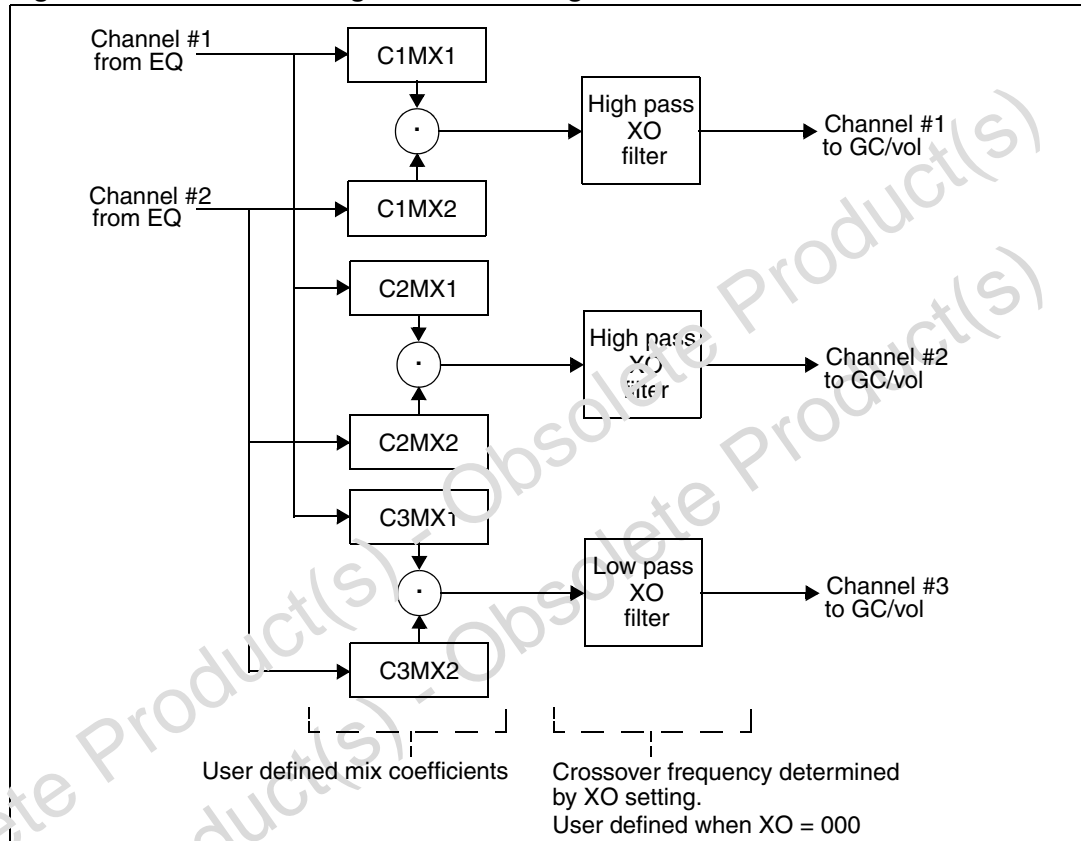

After mixing, STA323WQS also permits the implementation of crossover filters on all channels corresponding to 2.1 bass management operation. Channels 1 and 2 use a 1st order, high-pass filter and channel 3 uses a 2nd-order low-pass filter corresponding to the setting of the XO bits of I²C register 0x0C. If XO = 000, user specified crossover filters are used.

By default these coefficients correspond to pass-through. However, the user can write these coefficients in a similar way as the EQ biquads. When user-defined setting is selected, the user can only write 2nd-order crossover filters. This output is then passed on to the Volume and Limiter block.

8.5 Calculating 24-bit signed fractional numbers from a dB value

The pre-scale, mixing, and post-scale functions of the STA323WQS use 24-bit signed fractional multipliers to attenuate signals. These attenuations can also invert the phase and therefore range in value from -1 to +1.

It is possible to calculate the coefficient to use for a given negative dB value (attenuation) using the equations following.

- non-inverting phase numbers 0 to +1:
 - coefficient = round($8388607 * 10^{(dB/20)}$)
- inverting phase numbers 0 to -1:
 - coefficient = $16777216 - \text{round}(8388607 * 10^{(dB/20)})$

As can be seen by the preceding equations, the value for positive phase 0 dB is 0x7FFFFFFF and the value for negative phase 0 dB is 0x800000.

8.6 User defined coefficient RAM

8.6.1 Coefficient address register 1 (address 0x16)

D7	D6	D5	D4	D3	D2	D1	D0
CFA7	CFA6	CFA5	CFA4	CFA3	CFA2	CFA1	CFA0
0	0	0	0	0	0	0	0

8.6.2 Coefficient b1data register bits 23:16 (address 0x17)

D7	D6	D5	D4	D3	D2	D1	D0
C1B23	C1B22	C1B21	C1B20	C1B19	C1B18	C1B17	C1B16
0	0	0	0	0	0	0	0

8.6.3 Coefficient b1data register bits 15:8 (address 0x18)

D7	D6	D5	D4	D3	D2	D1	D0
C1B15	C1B14	C1B13	C1B12	C1B11	C1B10	C1B9	C1B8
0	0	0	0	0	0	0	0

8.6.4 Coefficient b1data register bits 7:0 (address 0x19)

D7	D6	D5	D4	D3	D2	D1	D0
C1B7	C1B6	C1B5	C1B4	C1B3	C1B2	C1B1	C1B0
0	0	0	0	0	0	0	0

8.6.5 Coefficient b2 data register bits 23:16 (address 0x1A)

D7	D6	D5	D4	D3	D2	D1	D0
C2B23	C2B22	C2B21	C2B20	C2B19	C2B18	C2B17	C2B16
0	0	0	0	0	0	0	0

8.6.6 Coefficient b2 data register bits 15:8 (address 0x1B)

D7	D6	D5	D4	D3	D2	D1	D0
C2B15	C2B14	C2B13	C2B12	C2B11	C2B10	C2B9	C2B8
0	0	0	0	0	0	0	0

8.6.7 Coefficient b2 data register bits 7:0 (address 0x1C)

D7	D6	D5	D4	D3	D2	D1	D0
C2B7	C2B6	C2B5	C2B4	C2B3	C2B2	C2B1	C2B0
0	0	0	0	0	0	0	0

8.6.8 Coefficient a1 data register bits 23:16 (address 0x1D)

D7	D6	D5	D4	D3	D2	D1	D0
C1B23	C1B22	C1B21	C1B20	C1B19	C1B18	C1B17	C1B16
0	0	0	0	0	0	0	0

8.6.9 Coefficient a1 data register bits 15:8 (address 0x1E)

D7	D6	D5	D4	D3	D2	D1	D0
C3B15	C3B14	C3B13	C3B12	C3B11	C3B10	C3B9	C3B8
0	0	0	0	0	0	0	0

8.6.10 Coefficient a1 data register bits 7:0 (address 0x1F)

D7	D6	D5	D4	D3	D2	D1	D0
C3B7	C3B6	C3B5	C3B4	C3B3	C3B2	C3B1	C3B0
0	0	0	0	0	0	0	0

8.6.11 Coefficient a2 data register bits 23:16 (address 0x20)

D7	D6	D5	D4	D3	D2	D1	D0
C4B23	C4B22	C4B21	C4B20	C4B19	C4B18	C4B17	C4B16
0	0	0	0	0	0	0	0

8.6.12 Coefficient a2 data register bits 15:8 (address 0x21)

D7	D6	D5	D4	D3	D2	D1	D0
C4B15	C4B14	C4B13	C4B12	C4B11	C4B10	C4B9	C4B8
0	0	0	0	0	0	0	0

8.6.13 Coefficient a2 data register bits 7:0 (address 0x22)

D7	D6	D5	D4	D3	D2	D1	D0
C4B7	C4B6	C4B5	C4B4	C4B3	C4B2	C4B1	C4B0
0	0	0	0	0	0	0	0

8.6.14 Coefficient b0 data register bits 23:16 (address 0x23)

D7	D6	D5	D4	D3	D2	D1	D0
C5B23	C5B22	C5B21	C5B20	C5B19	C5B18	C5B17	C5B16
0	0	0	0	0	0	0	0

8.6.15 Coefficient b0 data register bits 15:8 (address 0x24)

D7	D6	D5	D4	D3	D2	D1	D0
C5B15	C5B14	C5B13	C5B12	C5B11	C5B10	C5B9	C5B8
0	0	0	0	0	0	0	0

8.6.16 Coefficient b0 data register bits 7:0 (address 0x25)

D7	D6	D5	D4	D3	D2	D1	D0
C5B7	C5B6	C5B5	C5B4	C5B3	C5B2	C5B1	C5B0
0	0	0	0	0	0	0	0

8.6.17 Coefficient write control register (address 0x26)

D7	D6	D5	D4	D3	D2	D1	D0
				RA	R1	WA	W1
				0	0	0	0

Coefficients for EQ, Mix and Scaling are handled internally in the STA323WQS via RAM. Access to this RAM is available to the user via an I²C register interface. A collection of I²C registers are dedicated to this function. The first register contains base address of the coefficient: five sets of three registers store the values of the 24-bit coefficients to be written or that were read, and one contains bits used to control the reading or writing of the coefficients to RAM. The following are instructions for reading and writing coefficients.

8.7 Reading and writing coefficients

8.7.1 Reading a coefficient from RAM

1. Write 8-bits of address to I²C register 0x16.
2. Write 1 to bit R1 (D2) of I²C register 0x26.
3. Read top 8-bits of coefficient in I²C address 0x17.
4. Read middle 8-bits of coefficient in I²C address 0x18.
5. Read bottom 8-bits of coefficient in I²C address 0x19.

8.7.2 Reading a set of coefficients from RAM

1. Write 8-bits of address to I²C register 0x16.
2. Write 1 to bit RA (D3) of I²C register 0x26.
3. Read top 8-bits of coefficient in I²C address 0x17.
4. Read middle 8-bits of coefficient in I²C address 0x18.
5. Read bottom 8-bits of coefficient in I²C address 0x19.
6. Read top 8-bits of coefficient b2 in I²C address 0x1A.
7. Read middle 8-bits of coefficient b2 in I²C address 0x1B.
8. Read bottom 8-bits of coefficient b2 in I²C address 0x1C.
9. Read top 8-bits of coefficient a1 in I²C address 0x1D.
10. Read middle 8-bits of coefficient a1 in I²C address 0x1E.
11. Read bottom 8-bits of coefficient a1 in I²C address 0x1F.
12. Read top 8-bits of coefficient a2 in I²C address 0x20.
13. Read middle 8-bits of coefficient a2 in I²C address 0x21.
14. Read bottom 8-bits of coefficient a2 in I²C address 0x22.
15. Read top 8-bits of coefficient b0 in I²C address 0x23.
16. Read middle 8-bits of coefficient b0 in I²C address 0x24.
17. Read bottom 8-bits of coefficient b0 in I²C address 0x25.

8.7.3 Writing a single coefficient to RAM

1. Write 8-bits of address to I²C register 0x16.
2. Write top 8-bits of coefficient in I²C address 0x17.
3. Write middle 8-bits of coefficient in I²C address 0x18.
4. Write bottom 8-bits of coefficient in I²C address 0x19.
5. Write 1 to W1 bit in I²C address 0x26.

8.7.4 Writing a set of coefficients to RAM

1. Write 8-bits of starting address to I²C register 0x16.
2. Write top 8-bits of coefficient b1 in I²C address 0x17.
3. Write middle 8-bits of coefficient b1 in I²C address 0x18.
4. Write bottom 8-bits of coefficient b1 in I²C address 0x19.
5. Write top 8-bits of coefficient b2 in I²C address 0x1A.
6. Write middle 8-bits of coefficient b2 in I²C address 0x1B.
7. Write bottom 8-bits of coefficient b2 in I²C address 0x1C.
8. Write top 8-bits of coefficient a1 in I²C address 0x1D.
9. Write middle 8-bits of coefficient a1 in I²C address 0x1E.
10. Write bottom 8-bits of coefficient a1 in I²C address 0x1F.
11. Write top 8-bits of coefficient a2 in I²C address 0x20.
12. Write middle 8-bits of coefficient a2 in I²C address 0x21.
13. Write bottom 8-bits of coefficient a2 in I²C address 0x22.
14. Write top 8-bits of coefficient b0 in I²C address 0x23.
15. Write middle 8-bits of coefficient b0 in I²C address 0x24.
16. Write bottom 8-bits of coefficient b0 in I²C address 0x25.
17. Write 1 to WA bit in I²C address 0x26.

The mechanism for writing a set of coefficients to RAM provides a method of simultaneously updating the five coefficients corresponding to a given biquad (filter) to avoid possible unpleasant acoustic side-effects. When using this technique, the 8-bit address specifies the address of the biquad b1 coefficient (for example 0, 5, 10, 15, ..., 45 decimal), and the STA323WQS generates the RAM addresses as an offsets from this base value to write the complete set of coefficient data.

Table 69. RAM block for biquads, mixing, and scaling

Index (decimal)	Index (hex)		Coefficient	Default
0	0x00	Channel 1 - biquad 1	C1H10 (b1/2)	0x000000
1	0x01		C1H11 (b2)	0x000000
2	0x02		C1H12 (a1/2)	0x000000
3	0x03		C1H13 (a2)	0x000000
4	0x04		C1H14 (b0/2)	0x400000
5	0x05	Channel 1 - biquad 2	C1H20	0x000000
...
19	0x13	Channel 1 - biquad 4	C1H44	0x400000
20	0x14	Channel 2 - biquad 1	C2H10	0x000000
21	0x15		C2H11	0x000000
...
39	0x27	Channel 2 - biquad 4	C2H44	0x400000

Table 69. RAM block for biquads, mixing, and scaling (continued)

Index (decimal)	Index (hex)		Coefficient	Default
40	0x28	High-pass 2 nd -order filter For XO = 000	C12H0 (b1/2)	0x000000
41	0x29		C12H1 (b2)	0x000000
42	0x2A		C12H2 (a1/2)	0x000000
43	0x2B		C12H3 (a2)	0x000000
44	0x2C		C12H4 (b0/2)	0x400000
45	0x2D	Low-Pass 2 nd -order filter For XO = 000	C12L0 (b1/2)	0x000000
46	0x2E		C12L1 (b2)	0x000000
47	0x2F		C12L2 (a1/2)	0x000000
48	0x30		C12L3 (a2)	0x000000
49	0x31		C12L4 (b0/2)	0x400000
50	0x32	Channel 1 - post scale	C1PreS	0x7FFFFFFF
51	0x33	Channel 2 - post scale	C2PreS	0x7FFFFFFF
52	0x34	Channel 1 - post scale	C1PstS	0x7FFFFFFF
53	0x35	Channel 2 - post scale	C2PstS	0x7FFFFFFF
54	0x36	Channel 3 - post scale	C3PstS	0x7FFFFFFFh
55	0x37	Thermal warning - post scale	TWPstS	0x5A9DF7
56	0x38	Channel 1 - mix 1	C1MX1	0x7FFFFFFF
57	0x39	Channel 1 - mix 2	C1MX2	0x000000
58	0x3A	Channel 2 - mix 1	C2MX1	0x000000
59	0x3B	Channel 2 - mix 2	C2MX2	0x7FFFFFFF
60	0x3C	Channel 3 - mix 1	C3MX1	0x400000
61	0x3D	Channel 3 - mix 2	C3MX2	0x400000
62	0x3E	Unused		
63	0x3F	Unused		

8.8 Variable max power correction (address 0x27-0x28)

The MPCC bits determine the 16 MSBs of the MPC compensation coefficient. This coefficient is used in place of the default coefficient when MPCV = 1.

D7	D6	D5	D4	D3	D2	D1	D0
MPCC15	MPCC14	MPCC13	MPCC12	MPCC11	MPCC10	MPCC9	MPCC8
0	0	1	0	1	1	0	1
MPCC7	MPCC6	MPCC5	MPCC4	MPCC3	MPCC2	MPCC1	MPCC0
1	1	0	0	0	0	0	0

8.9 Fault detect recovery (address 0x2B - 0x2C)

FDRC bits specify the 16-bit fault detect recovery time delay. When FAULT is active, the TRISTATE output immediately goes low and is held low for the time period specified by this constant. A constant value of 0x0001 in this register is approximately 0.083 ms. The default value of 0x000C specifies approximately 0.1 ms.

D7	D6	D5	D4	D3	D2	D1	D0
FRDC15	FRDC14	FRDC13	FRDC12	FRDC11	FRDC10	FRDC9	FRDC8
0	0	0	0	0	0	0	0
FRDC7	FRDC6	FRDC5	FRDC4	FRDC3	FRDC2	FRDC1	FRDC0
0	0	0	0	1	1	0	0

8.10 Status indicator register (address 0x2D)

D7	D6	D5	D4	D3	D2	D1	D0
PLULL						FAULT	TWARN
0						1	1

STATUS register bits serve the purpose of communicating the detected error or warning condition to the user. This is a read-only register and writing to this register would not be of any consequence.

8.10.1 Thermal warning indicator

Table 70. Thermal warning indicator

Bit	R/W	RST	Name	Description
0	RO	1	RWRAN	0: thermal warning detected 1: normal operation (no thermal warning)

If the power stage thermal operating conditions are exceeded, the thermal warning indicator transmits a signal to the digital logic block to initiate a corrective procedure. This register bit is set to 0 to indicate a thermal warning and it reverts back to its default state as soon as the cause of the thermal warning has been corrected.

8.10.2 Fault detect indicator

Table 71. Fault detect indicator

Bit	R/W	RST	Name	Description
1	RO	1	FAULT	0: fault issued from the power stage 1: normal operation (no fault)

As soon as the power stage issues a Fault error signal, thereby initiating the Fault recovery procedure described in [Section 8.9](#), this register bit is set to 0 to indicate the error to the user. As soon as the fault condition (over-current or thermal) is corrected, this bit is reset back to its default state.

8.10.3 PLL unlock indicator

Table 72. PLL unlock indicator

Bit	R/W	RST	Name	Description
7	RO	0	PLLUL	0: normal operation (PLL is in a locked state) 1: PLL unlock is detected (due to probable clock loss)

Under normal conditions (with the correct clock) the PLL is locked into an internal clocking frequency. However, if the clock is insufficient or if it is abruptly lost, the PLL lock state is lost and this information is relayed to the user via setting the PLLUL bit of the Status register to 1. As soon as the PLL reverts back to a locked state, this bit is set to 0.

9 Package information

Figure 53. PowerSO-36 slug down outline drawing

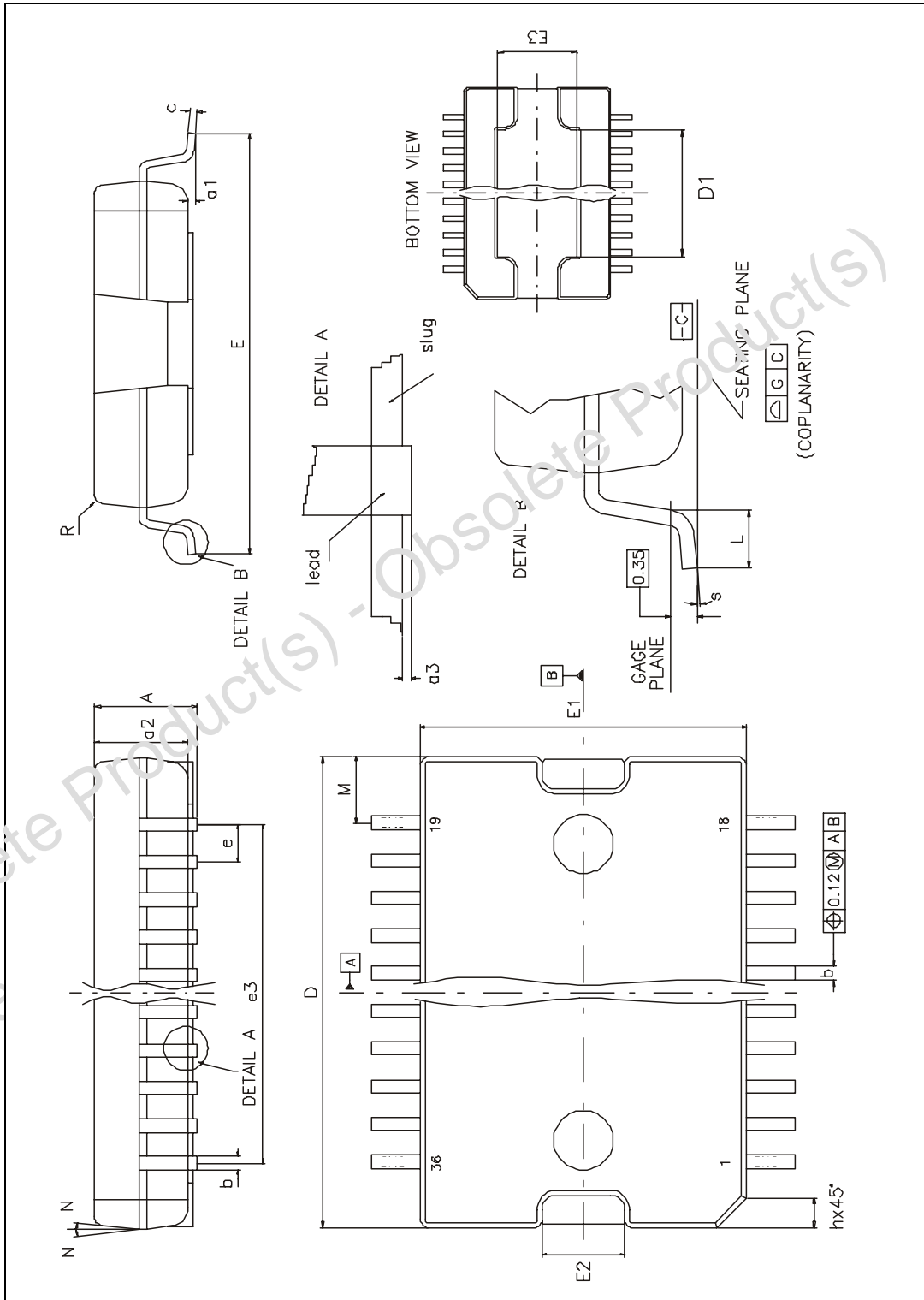

Table 73. PowerSO-36 slug down dimensions

Symbol	mm			inch		
	Min	Typ	Max	Min	Typ	Max
A	-	-	3.60	-	-	0.142
a1	0.10	-	0.30	.004	-	.012
a2	-	-	3.30	-	-	0.130
a3	0	-	0.10	0	-	.004
b	0.22	-	0.38	0.009	-	0.015
c	0.23	-	0.32	0.009	-	0.013
D	15.80	-	16.00	0.622	-	0.630
D1	9.40	-	9.80	0.370	-	0.380
E	13.90	-	14.50	0.547	-	0.571
E1	10.90	-	11.10	0.429	-	0.437
E2	-	-	2.90	-	-	0.114
E3	5.80	-	6.20	0.228	-	0.244
e	-	0.65	-	-	0.026	-
e3	-	11.05	-	-	0.435	-
G	0	-	0.10	0	-	0.004
H	15.50	-	15.90	0.610	-	0.626
h	-	-	1.10	-	-	0.043
L	0.80	-	1.10	0.031	-	0.043
M	2.25	-	2.60	0.089	-	0.102
N	-	-	10 degrees	-	-	10 degrees
R	-	0.30	-	-	0.012	-
s	-	-	8 degrees	-	-	8 degrees

In order to meet environmental requirements, ST offers these devices in ECOPACK® packages. These packages have a Lead-free second level interconnect. The category of second Level Interconnect is marked on the package and on the inner box label, in compliance with JEDEC Standard JESD97. The maximum ratings related to soldering conditions are also marked on the inner box label. ECOPACK is an ST trademark. ECOPACK specifications are available at: www.st.com.

10 License information

Supply of this product does not convey a license under the relevant intellectual property of the companies mentioned in this chapter nor imply any right to use this intellectual property in any finished end-user or ready to use final product. An independent license for such use is required and can be obtained by contacting the company or companies concerned. Once the license is obtained, a copy must be sent to STMicroelectronics. The details of all the features requiring licenses are not provided within the datasheet and register manual. They are provided only after a copy of the license has been received by STMicroelectronics.

The feature requiring license is:

QXpander[®], QHD[®]

QHD[®] and QXpander[®] are intellectual property of QSound Labs Inc. A license can be obtained with the STA323WQS via STMicroelectronics, please contact the HPC Audio Division Product Manager for details.

Alternatively the license can be obtained directly from QSound Labs Inc.

For details please contact:

sales@qsound.com

or

QSound Labs, Inc

400 - 3115 12th Street NE

Calgary, AB

Canada T2E 7J2

11 Trademarks and other acknowledgements

DDX is a registered trademark of Apogee Technology Inc.

ECOPACK is a registered trademark of STMicroelectronics.

QHD and QXpander are registered trademarks of QSound Labs Inc.

Obsolete Product(s) - Obsolete Product(s)
Obsolete Product(s) - Obsolete Product(s)

12 Revision history

Table 74. Document revision history

Date	Revision	Changes
05-May-2008	2	Updated pin 1 connection General presentation revision
02-Jan-2007	1	Initial release

Obsolete Product(s) - Obsolete Product(s)
Obsolete Product(s) - Obsolete Product(s)

Please Read Carefully:

Information in this document is provided solely in connection with ST products. STMicroelectronics NV and its subsidiaries ("ST") reserve the right to make changes, corrections, modifications or improvements, to this document, and the products and services described herein at any time, without notice.

All ST products are sold pursuant to ST's terms and conditions of sale.

Purchasers are solely responsible for the choice, selection and use of the ST products and services described herein, and ST assumes no liability whatsoever relating to the choice, selection or use of the ST products and services described herein.

No license, express or implied, by estoppel or otherwise, to any intellectual property rights is granted under this document. If any part of this document refers to any third party products or services it shall not be deemed a license grant by ST for the use of such third party products or services, or any intellectual property contained therein or considered as a warranty covering the use in any manner whatsoever of such third party products or services or any intellectual property contained therein.

UNLESS OTHERWISE SET FORTH IN ST'S TERMS AND CONDITIONS OF SALE ST DISCLAIMS ANY EXPRESS OR IMPLIED WARRANTY WITH RESPECT TO THE USE AND/OR SALE OF ST PRODUCTS INCLUDING WITHOUT LIMITATION IMPLIED WARRANTIES OF MERCHANTABILITY, FITNESS FOR A PARTICULAR PURPOSE (AND THEIR EQUIVALENTS UNDER THE LAWS OF ANY JURISDICTION), OR INFRINGEMENT OF ANY PATENT, COPYRIGHT OR OTHER INTELLECTUAL PROPERTY RIGHT.

UNLESS EXPRESSLY APPROVED IN WRITING BY AN AUTHORIZED ST REPRESENTATIVE, ST PRODUCTS ARE NOT RECOMMENDED, AUTHORIZED OR WARRANTED FOR USE IN MILITARY, AIR CRAFT, SPACE, LIFE SAVING, OR LIFE SUSTAINING APPLICATIONS, NOR IN PRODUCTS OR SYSTEMS WHERE FAILURE OR MALFUNCTION MAY RESULT IN PERSONAL INJURY, DEATH, OR SEVERE PROPERTY OR ENVIRONMENTAL DAMAGE. ST PRODUCTS WHICH ARE NOT SPECIFIED AS "AUTOMOTIVE GRADE" MAY ONLY BE USED IN AUTOMOTIVE APPLICATIONS AT USER'S OWN RISK.

Resale of ST products with provisions different from the statements and/or technical features set forth in this document shall immediately void any warranty granted by ST for the ST product or service described herein and shall not create or extend in any manner whatsoever, any liability of ST.

ST and the ST logo are trademarks or registered trademarks of ST in various countries.

Information in this document supersedes and replaces all information previously supplied.

The ST logo is a registered trademark of STMicroelectronics. All other names are the property of their respective owners.

© 2008 STMicroelectronics - All rights reserved

STMicroelectronics group of companies

Australia - Belgium - Brazil - Canada - China - Czech Republic - Finland - France - Germany - Hong Kong - India - Israel - Italy - Japan - Malaysia - Malta - Morocco - Singapore - Spain - Sweden - Switzerland - United Kingdom - United States of America

www.st.com