

Low voltage 4 Ω SPDT switch



SOT23-6L

Features

- High speed:
 - $t_{PD} = 0.3 \text{ ns}$ (typ.) at $V_{CC} = 5 \text{ V}$
 - $t_{PD} = 0.4 \text{ ns}$ (typ.) at $V_{CC} = 3.3 \text{ V}$
- Low power dissipation:
 - $I_{CC} = 1 \mu\text{A}$ (max.) at $T_A = 25 \text{ }^\circ\text{C}$
- Low on resistance:
 - $R_{ON} = 4 \Omega$ (max. $T_A = 25 \text{ }^\circ\text{C}$) at $V_{CC} = 5 \text{ V}$
 - $R_{ON} = 6 \Omega$ (typ.) at $V_{CC} = 3 \text{ V}$
- Wide operating voltage range:
 - $V_{CC} \text{ (OPR)} = 1.8 \text{ V to } 5.5 \text{ V}$ single supply

Description

The STG719 is a high-speed S.P.D.T. (single pole double throw) switch developed thanks to silicon gate C²MOS technology. It is designed to operate from 1.8 V to 5.5 V, making this device ideal for portable applications, audio signal routing, video switching, mobile and communication systems.

It offers 4 Ω on-resistance max. at 5 V 25 °C and very low on-resistance flatness. Additional key features are fast switching speed ($t_{ON} = 7 \text{ ns}$, $t_{OFF} = 4.5 \text{ ns}$), break before make delay time and low power consumption.

All inputs and outputs are equipped with protection circuits against static discharge, giving them ESD immunity and transient excess voltage. It is available in the commercial and extended temperature range.

Maturity status link	
STG719	

Order code	
Package	SOT23-6L
Tape and reel	STG719STR

1 Pin connection

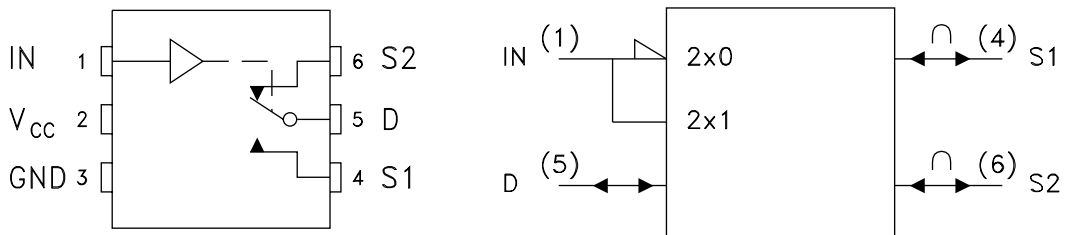
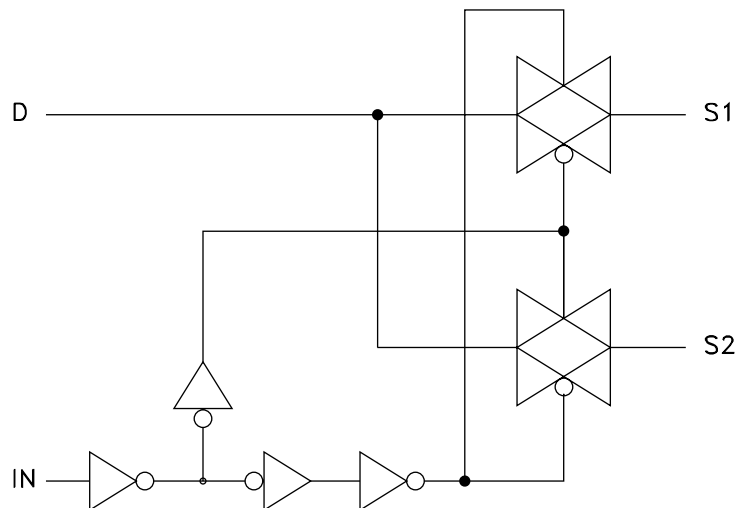
Figure 1. Pin connection and IEC logic symbols

Figure 2. Input equivalent circuit

Table 1. Pin description

Pin n°	Symbol	Name and function
1	IN	Control
4, 6	S1, S2	Independent channel
5	D	Common channel
2	V _{CC}	Positive supply voltage
3	GND	Ground (0 V)

Table 2. Truth table

IN	Switch S1	Switch S2
L	ON	OFF
H	OFF	ON

2 Maximum ratings

Table 3. Absolute maximum ratings

Symbol	Parameter	Value	Unit
V_{CC}	Supply voltage	-0.5 to +7.0	V
V_I	DC input voltage	-0.5 to $V_{CC} + 0.5$	V
V_{IC}	DC control input voltage	-0.5 to $V_{CC} + 0.5$	V
V_O	DC output voltage	-0.5 to $V_{CC} + 0.5$	V
I_{IK}	DC input diode current	± 20	mA
I_{OK}	DC output diode current	± 20	mA
I_O	DC output current	± 50	mA
I_{CC} or I_{GND}	DC V_{CC} or ground current	± 50	mA
I_{P-P}	Peak to peak current	100	mA
T_{stg}	Storage temperature	-65 to +150	°C
T_L	Lead temperature (10 s.)	300	°C

Note: *Absolute maximum ratings are those values beyond which damage to the device may occur. Functional operation under these conditions is not implied.*

Table 4. Recommended operating conditions

Symbol	Parameter	Value	Unit
V_{CC}	Supply voltage ⁽¹⁾	1.8 to 5.5	V
V_I	Input voltage	0 to V_{CC}	V
V_{IC}	Control input voltage	0 to V_{CC}	V
V_O	Output voltage	0 to V_{CC}	V
T_{op}	Operating temperature	-55 to 125	°C
dt/dv	Input rise and fall time on control pin ⁽²⁾	0 to 10	ns/V
dt/dv	Input rise and fall time on I/O pins	0 to DC	ns/V

1. Truth table guaranteed: 1.2 V to 6 V.
2. V_{IN} from 30% to 70% of V_{CC} .

Table 5. DC specifications

Symbol	Parameter	Test conditions		Value						Unit	
		V _{CC} (V)		T _A = 25 °C			-40 to 85 °C		-55 to 125 °C		
				Min.	Typ.	Max.	Min.	Max.	Min.		Max.
V _{IHC}	High level control input voltage	3.3 ⁽¹⁾		2.0			2.0		2.0		V
		5.0 ⁽²⁾		2.4			2.4		2.4		
		5.0 ⁽³⁾		2.25			2.25		2.25		
V _{ILC}	Low level control input voltage	3.3 ⁽¹⁾				0.4		0.4		0.4	V
		5.0 ⁽²⁾				0.8		0.8		0.8	
R _{ON}	ON-resistance	3.3 ⁽¹⁾	V _S = 0 to V _{CC}		6	7		10		12	Ω
		5.0 ⁽²⁾	I _S = 10 mA			4		5		6	
ΔR _{ON}	ON-resistance	3.3 ⁽¹⁾	V _S = 0 to V _{CC}		0.1			0.4			Ω
		5.0 ⁽²⁾	I _S = 10 mA		0.1			0.4			
R _{FLATON}	ON-resistance flatness	3.3 ⁽¹⁾	V _S = 0 to V _{CC}		2.5						Ω
		5.0 ⁽²⁾	I _S = 10 mA		0.75						
I _{SOFF}	Source OFF leakage	3.3 ⁽¹⁾	V _S = 1 V or V _{CC} V _{DD} = V _{CC} or 1 V V _{IN} = V _{CC} or GND		±0.01	±0.25		± 0.35		± 3.5	nA
		5.0 ⁽²⁾			±0.01	±0.25		± 0.35		± 3.5	
I _{SON}	Channel ON leakage	3.3 ⁽¹⁾	V _S = V _D = 1 V to V _{CC} - 2.5 V V _{IN} = V _{IHC}		±0.01	±0.25		± 0.35		± 3.5	nA
		5.0 ⁽²⁾			±0.01	±0.25		± 0.35		± 3.5	
I _{IN}	Control input leakage current	3.3 ⁽¹⁾	V _I = V _{IH} or V _{IL}		0.005			±0.1		±1	μA
		5.0 ⁽²⁾			0.005			±0.1		±1	
I _{CC}	Quiescent supply current	3.3 ⁽¹⁾	V _I = V _{CC} or GND		0.001	1		1		2	μA
		5.0 ⁽²⁾			0.001			1		2	

1. Voltage range is 3.3 V ± 0.3 V
2. Voltage range is 5 V ± 0.5 V
3. Voltage range is 5 V ± 0.125 V

3 Electrical characteristics

 $C_L = 35 \text{ pF}$, $R_L = 300 \Omega$
Table 6. AC electrical characteristics

Symbol	Parameter	Test conditions		Value						Unit	
		V _{CC} (V)		T _A = 25 °C			-40 to 85 °C		-55 to 125 °C		
				Min.	Typ.	Max.	Min.	Max.	Min.		Max.
t _{PD}	Delay time	3.3 ⁽¹⁾	V _S = 3 V square wave f = 1 MHz t _r = t _f = 6 ns		0.4	0.8		1.2		2.4	ns
		5.0 ⁽²⁾			0.3	0.6		1.0		2.0	
t _{ON}	ON channel time	3.3 ⁽¹⁾	V _S = 2 V		10			16		19	ns
		5.0 ⁽²⁾	V _S = 3 V		7			11		13	
t _{OFF}	OFF channel time	3.3 ⁽¹⁾	V _S = 2 V		5.5			7		8.5	ns
		5.0 ⁽²⁾	V _S = 3 V		4.5			6		7.5	
t _D	Break before make time delay	3.3 ⁽¹⁾	V _S = 2 V	1	4						ns
		5.0 ⁽²⁾	V _S = 3 V	1	4						
C _{SOFF}	OFF channel				19						pF
C _{SON}	ON channel				33						pF

1. Voltage range is 3.3 V ± 0.3 V

2. Voltage range is 5.0 V ± 0.5 V

 GND = 0 V; T_A = 25°C

Table 7. Analog switch characteristics

Symbol	Parameter	Test conditions		Value	Unit
		V _{CC} (V)		Typ.	
f _{MAX}	Frequency response (switch ON)	3.3 ⁽¹⁾	Bandwidth at -3 dB	200	MHz
		5.0 ⁽²⁾		200	
	Feed through attenuation (switch OFF)	3.3 ⁽¹⁾	f _{IN} = 10 MHz sine wave	-40	dB
		⁽¹⁾	f = 1 MHz sine wave	-74	
		5.0 ⁽²⁾	f _{IN} = 10 MHz sine wave	-40	
		5.0 ⁽²⁾	f _{IN} = 1 MHz sine wave	-74	
	Crosstalk (control input to signal output)	3.3 ⁽¹⁾	f _{IN} = 10 MHz sine wave	-39	dB
		⁽¹⁾	f = 1 MHz sine wave	-52	
		5.0 ⁽²⁾	f _{IN} = 10 MHz sine wave	-39	
		5.0 ⁽²⁾	f _{IN} = 1 MHz sine wave	-52	

1. Voltage range is 3.3 V ± 0.3 V

2. Voltage range is 5.0 V ± 0.5 V

4 Test circuits

Figure 3. On-resistance

Figure 4. Off isolation

Figure 5. On leakage

Figure 6. Bandwidth

Figure 7. Off leakage

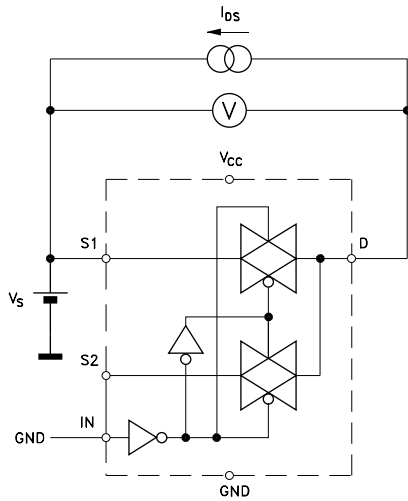
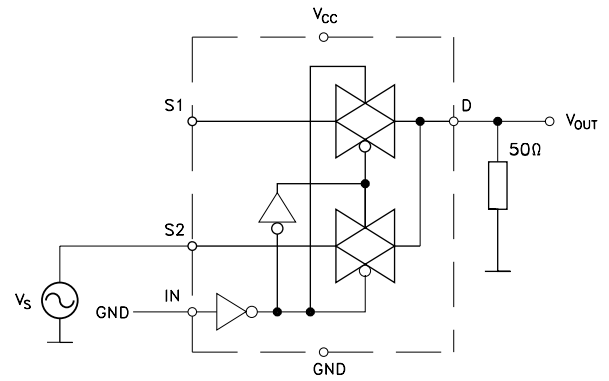
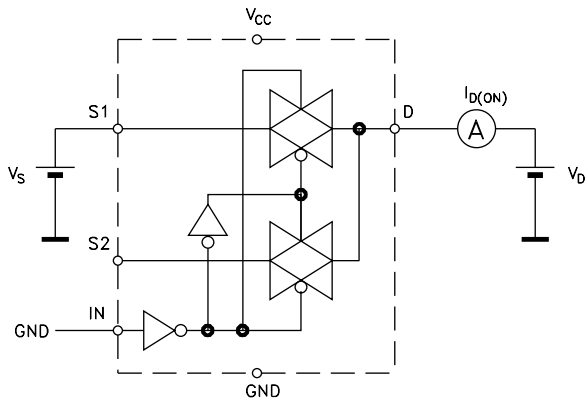
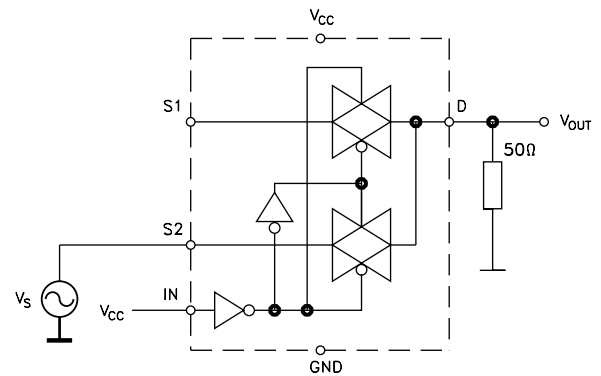
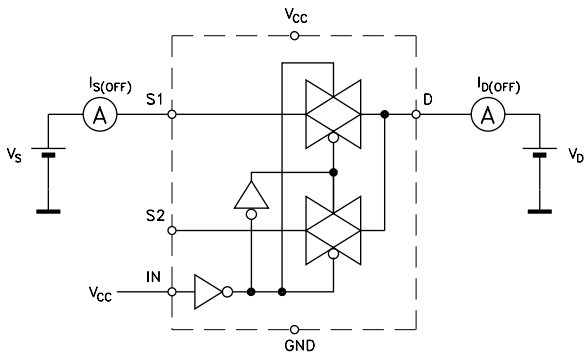
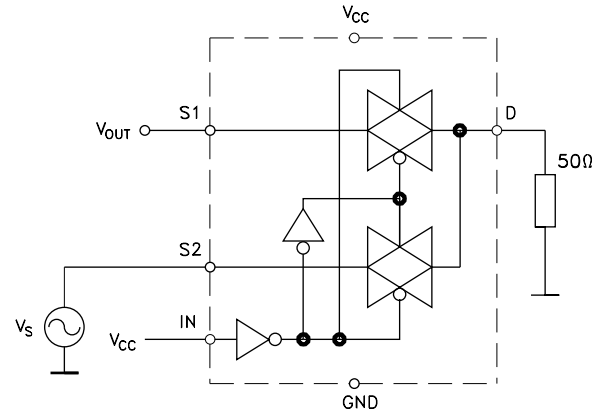
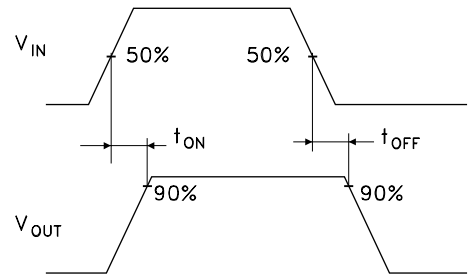
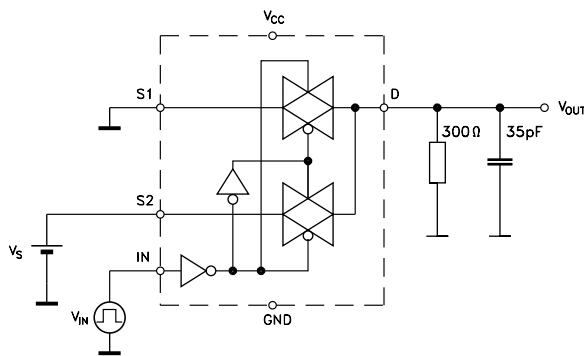
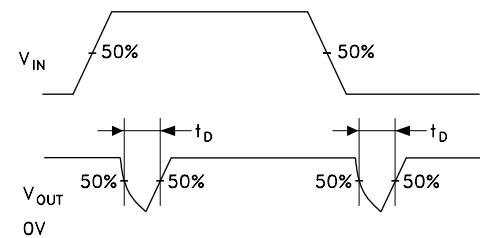
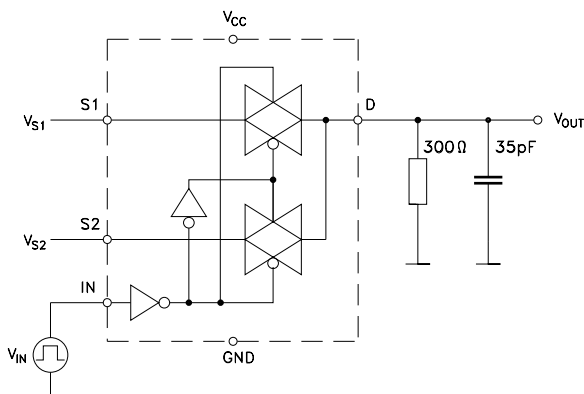
Figure 8. Channel-to-channel crosstalk

Figure 9. Switching times

Figure 10. Break before make delay time

5 Package information

In order to meet environmental requirements, ST offers these devices in different grades of **ECOPACK** packages, depending on their level of environmental compliance. ECOPACK specifications, grade definitions and product status are available at: www.st.com. ECOPACK is an ST trademark.

5.1 SOT23-6L package information

Figure 11. SOT23-6L package outline

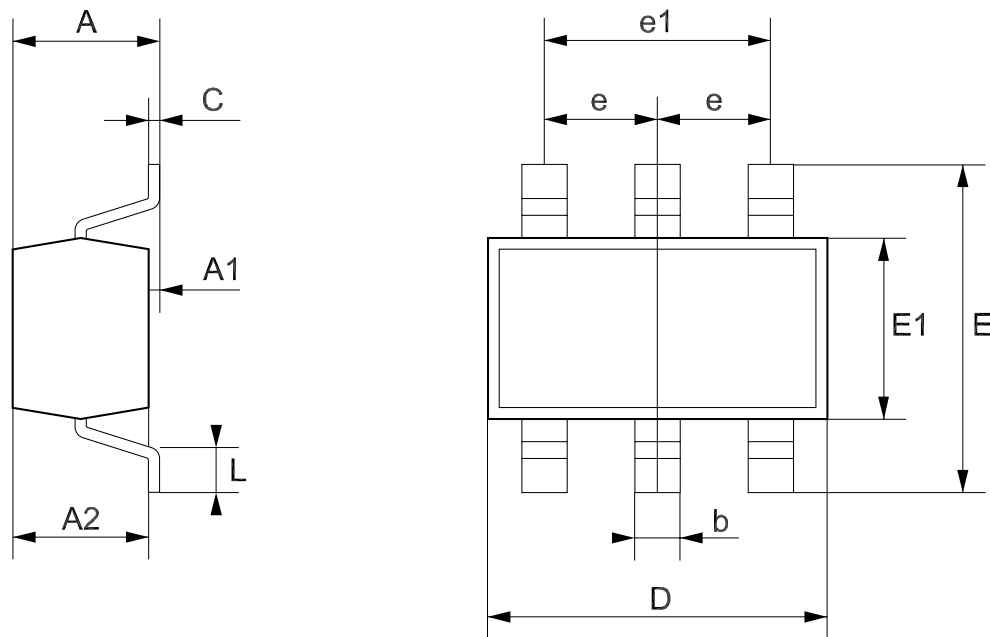
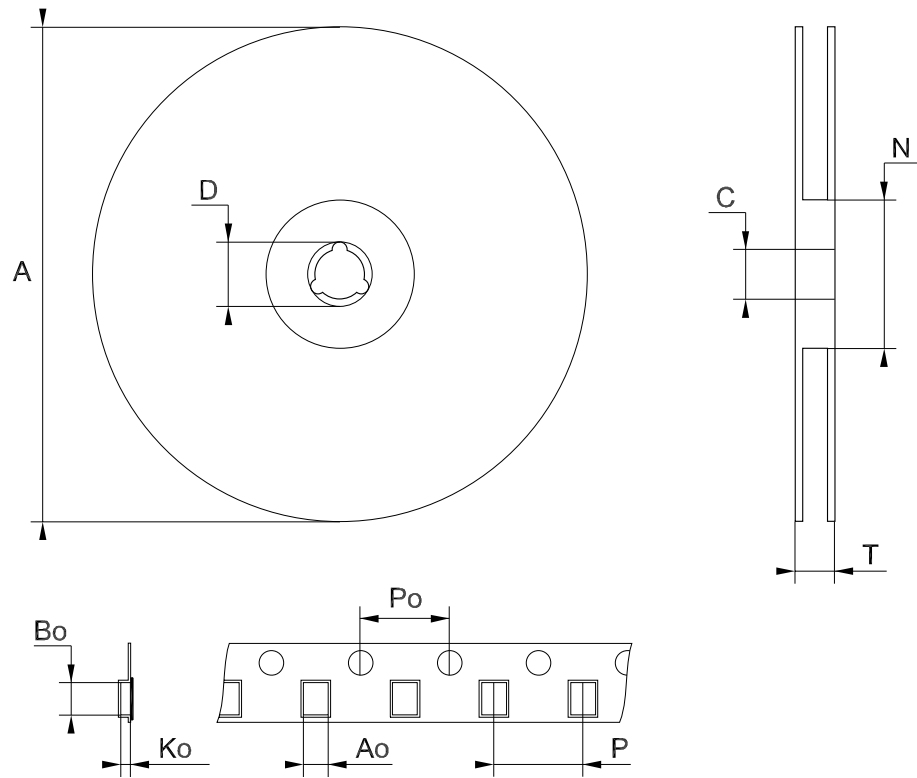

Table 8. SOT23-6L mechanical data

Dim.	mm			mils		
	Min.	Typ.	Max.	Min.	Typ.	Max.
A	0.90		1.45	35.4		57.1
A1	0.00		0.15	0.0		5.9
A2	0.90		1.30	35.4		51.2
b	0.35		0.50	13.7		19.7
C	0.09		0.20	3.5		7.8
D	2.80		3.00	110.2		118.1
E	2.60		3.00	102.3		118.1
E1	1.50		1.75	59.0		68.8
e		0.95			37.4	
e1		1.9			74.8	
L	0.35		0.55	13.7		21.6

5.2 SOT23-6L packing information

Figure 12. SOT23-6L tape and reel outline



Note: Drawing not in scale

Table 9. SOT23-6L tape and reel data

Dim.	mm			inch		
	Min.	Typ.	Max.	Min.	Typ.	Max.
A			180			7.086
C	12.8	13.0	13.2	0.504	0.512	0.519
D	20.2			0.795		
N	60			2.362		
T			14.4			0.567
Ao	3.13	3.23	3.33	0.123	0.127	0.131
Bo	3.07	3.17	3.27	0.120	0.124	0.128
Ko	1.27	1.37	1.47	0.050	0.054	0.058
Po	3.9	4.0	4.1	0.153	0.157	0.161
P	3.9	4.0	4.1	0.153	0.157	0.161

Revision history

Table 10. Document revision history

Date	Revision	Changes
25-Nov-2004	8	Mistake on figure 1.
12-Sep-2019	9	Add new test condition V_{ICH} in Table 5. DC specifications.
15-Mar-2021	10	Added new I_{P-P} parameter in Table 3. Absolute maximum ratings.

Contents

1	Pin connection	2
2	Maximum ratings	4
3	Electrical characteristics	6
4	Test circuits	7
5	Package information	9
5.1	SOT323-6L package information	9
5.2	SOT23-6L packing information	10
	Revision history	11
	Contents	12

List of tables

Table 1.	Pin description	2
Table 2.	Truth table	3
Table 3.	Absolute maximum ratings	4
Table 4.	Recommended operating conditions	4
Table 5.	DC specifications	5
Table 6.	AC electrical characteristics	6
Table 7.	Analog switch characteristics	6
Table 8.	SOT23-6L mechanical data	9
Table 9.	SOT23-6L tape and reel data	10
Table 10.	Document revision history	11

List of figures

Figure 1.	Pin connection and IEC logic symbols	2
Figure 2.	Input equivalent circuit	2
Figure 3.	On-resistance	7
Figure 4.	Off isolation	7
Figure 5.	On leakage	7
Figure 6.	Bandwidth	7
Figure 7.	Off leakage	8
Figure 8.	Channel-to-channel crosstalk	8
Figure 9.	Switching times	8
Figure 10.	Break before make delay time	8
Figure 11.	SOT23-6L package outline	9
Figure 12.	SOT23-6L tape and reel outline	10

IMPORTANT NOTICE – PLEASE READ CAREFULLY

STMicroelectronics NV and its subsidiaries (“ST”) reserve the right to make changes, corrections, enhancements, modifications, and improvements to ST products and/or to this document at any time without notice. Purchasers should obtain the latest relevant information on ST products before placing orders. ST products are sold pursuant to ST’s terms and conditions of sale in place at the time of order acknowledgement.

Purchasers are solely responsible for the choice, selection, and use of ST products and ST assumes no liability for application assistance or the design of Purchasers’ products.

No license, express or implied, to any intellectual property right is granted by ST herein.

Resale of ST products with provisions different from the information set forth herein shall void any warranty granted by ST for such product.

ST and the ST logo are trademarks of ST. For additional information about ST trademarks, please refer to www.st.com/trademarks. All other product or service names are the property of their respective owners.

Information in this document supersedes and replaces information previously supplied in any prior versions of this document.

© 2021 STMicroelectronics – All rights reserved