

1200 V, 75 A trench gate field-stop M series low loss IGBT die in D8 packing

Datasheet - production data

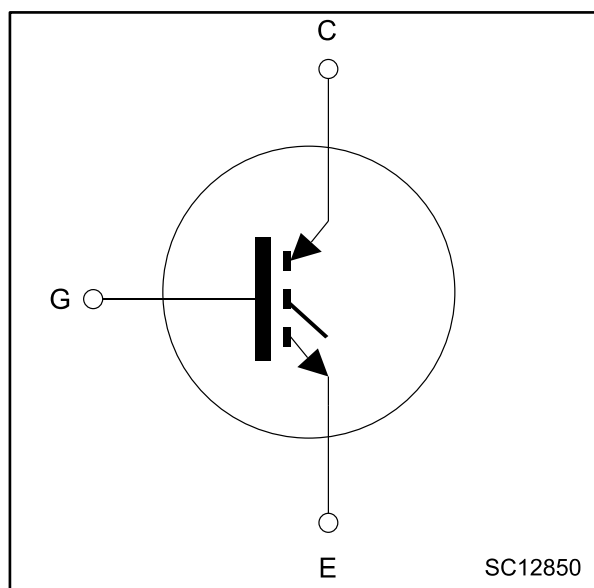

Features

- 10 μ s of short-circuit withstand time
- Low $V_{CE(sat)} = 1.85$ V (typ.) @ $I_C = 75$ A
- Positive $V_{CE(sat)}$ temperature coefficient
- Tight parameter distribution
- Maximum junction temperature: $T_J = 175$ °C

Applications

- Motor control
- Industrial drives
- PFC
- UPS
- Solar
- General purpose inverter

Description

This device is an IGBT developed using an advanced proprietary trench gate field-stop structure. The device is part of the M series IGBTs, which represent an optimal balance between inverter system performance and efficiency where low-loss and short-circuit functionality are essential. Furthermore, the positive $V_{CE(sat)}$ temperature coefficient and tight parameter distribution result in safer paralleling operation.

Table 1: Device summary

Order code	V_{CE}	I_C	Die size	Packing
STG75M120F3D8	1200 V	75 A	8.03 x 9.36 mm ²	D8

Contents

- 1 Mechanical parameters 3**
- 2 Electrical ratings 4**
 - 2.1 Absolute maximum ratings 4
 - 2.2 Electrical characteristics..... 4
- 3 Die layout 6**
- 4 Additional information 7**
 - 4.1 Additional testing and screening 7
 - 4.2 Shipping 7
 - 4.3 Handling..... 7
 - 4.4 Wafer/die storage..... 7
- 5 Revision history 8**



1 Mechanical parameters

Table 2: Mechanical parameters

Symbol		Value	Unit
Die size including scribe line		8.03 x 9.36	mm ²
Die thickness		110	μm
Front side passivation		Silicone nitride	
Emitter pad size including gate pad (x2)		7.00 x 4.03	mm ²
Gate pad size		1.61 x 1.01	mm ²
Front side metallization	composition	AlCu	
	thickness	4.5	μm
Back side metallization	composition	Al/Ti/NiV/Ag	
	thickness	0.65	μm
Die bond		Electrically conductive glue or soft solder	
Recommended wire bonding		≤500	μm

2 Electrical ratings

2.1 Absolute maximum ratings

Table 3: Absolute maximum ratings ($T_J = 25\text{ °C}$ unless otherwise specified)

Symbol	Parameter	Value	Unit
V_{CES}	Collector-emitter voltage ($V_{GE} = 0\text{ V}$)	1200	V
V_{GE}	Gate-emitter voltage	± 20	V
$I_{CN}^{(1)}$	Continuous collector current at $T = 100\text{ °C}$	75	A
$I_{CP}^{(1)(2)}$	Pulsed collector current, t_p limited by T_{Jmax}	225	A
$t_{sc}^{(3)}$	Short -circuit withstand time $V_{CC} = 600\text{ V}$, $V_{GE} = 15\text{ V}$, $V_{CE(peak)} \leq 1200\text{ V}$, $T_{Jstart} \leq 150\text{ °C}$	10	μs
T_J	Operating junction temperature range	-55 to 175	$^{\circ}\text{C}$

Notes:

(1) Nominal collector current for die packaged in ST power module solution. Current level depends on the assembly thermal properties and is limited by maximum junction temperature.

(2) Pulse width is limited by maximum junction temperature.

(3) Not tested at chip level, verified by design/characterization.

2.2 Electrical characteristics

Table 4: Static characteristics (tested on wafer unless otherwise specified)

Symbol	Parameter	Test conditions	Min.	Typ.	Max.	Unit
$V_{(BR)CES}$	Collector-emitter breakdown voltage	$I_C = 1\text{ mA}$, $V_{GE} = 0\text{ V}$	1200			V
$V_{CE(sat)}$	Collector-emitter saturation voltage	$V_{GE} = 15\text{ V}$, $I_C = 15\text{ A}$			1.7	V
$V_{GE(th)}$	Gate threshold voltage	$V_{CE} = V_{GE}$, $I_C = 1\text{ mA}$	5	6	7	V
I_{CES}	Collector cut-off current	$V_{GE} = 0\text{ V}$, $V_{CE} = 1200\text{ V}$			100	μA
I_{GES}	Gate-emitter leakage current	$V_{CE} = 0\text{ V}$, $V_{GE} = \pm 20\text{ V}$			± 500	μA

Table 5: Electrical characteristics (not tested at chip level, verified by design/characterization)

Symbol	Parameter	Test conditions	Min.	Typ.	Max.	Unit
$V_{CE(sat)}$	Collector-emitter saturation voltage	$V_{GE} = 15\text{ V}$, $I_C = 75\text{ A}$	-	1.85	2.3	V
		$V_{GE} = 15\text{ V}$, $I_C = 75\text{ A}$, $T_J = 150\text{ °C}$	-	2.15		V
R_G	Intrinsic gate resistance	$f = 1\text{ MHz}$	-	5		Ω
C_{ies}	Input capacitance	$V_{CE} = 25\text{ V}$, $f = 1\text{ MHz}$, $V_{GE} = 0\text{ V}$	-	4700		pF
C_{oes}	Output capacitance		-	350		pF
C_{res}	Reverse transfer capacitance		-	190		pF
Q_g	Total gate charge	$V_{CC} = 960\text{ V}$, $I_C = 75\text{ A}$, $V_{GE} = -15\text{ to }15\text{ V}$	-	350		nC

Table 6: Switching characteristics on inductive load

Symbol	Parameter	Test conditions	Min.	Typ.	Max.	Unit
$t_{d(on)}$	Turn-on delay time	$V_{CC} = 600 \text{ V}$, $I_C = 75 \text{ A}$, $V_{GE} = \pm 15 \text{ V}$, $R_G = 6.8 \Omega$	-	168	-	ns
t_r	Current rise time		-	45	-	ns
$t_{d(off)}$	Turn-off-delay time		-	229	-	ns
t_f	Current fall time		-	103	-	ns
$E_{off}^{(1)}$	Turn-off switching energy		-	4.2	-	mJ
$t_{d(on)}$	Turn-on delay time	$V_{CC} = 600 \text{ V}$, $I_C = 75 \text{ A}$, $V_{GE} = \pm 15 \text{ V}$, $R_G = 6.8 \Omega$, $T_J = 150 \text{ }^\circ\text{C}$	-	168	-	ns
t_r	Current rise time		-	49	-	ns
$t_{d(off)}$	Turn-off-delay time		-	229	-	ns
t_f	Current fall time		-	168	-	ns
$E_{off}^{(1)}$	Turn-off switching energy		-	5.7	-	mJ

Notes:

⁽¹⁾Including the tail of the collector current.



The aforementioned values are not tested at chip level and are strongly dependent on the package/module design and the mounting technology.

3 Die layout

Figure 1: Die drawing (dimensions are in mm)

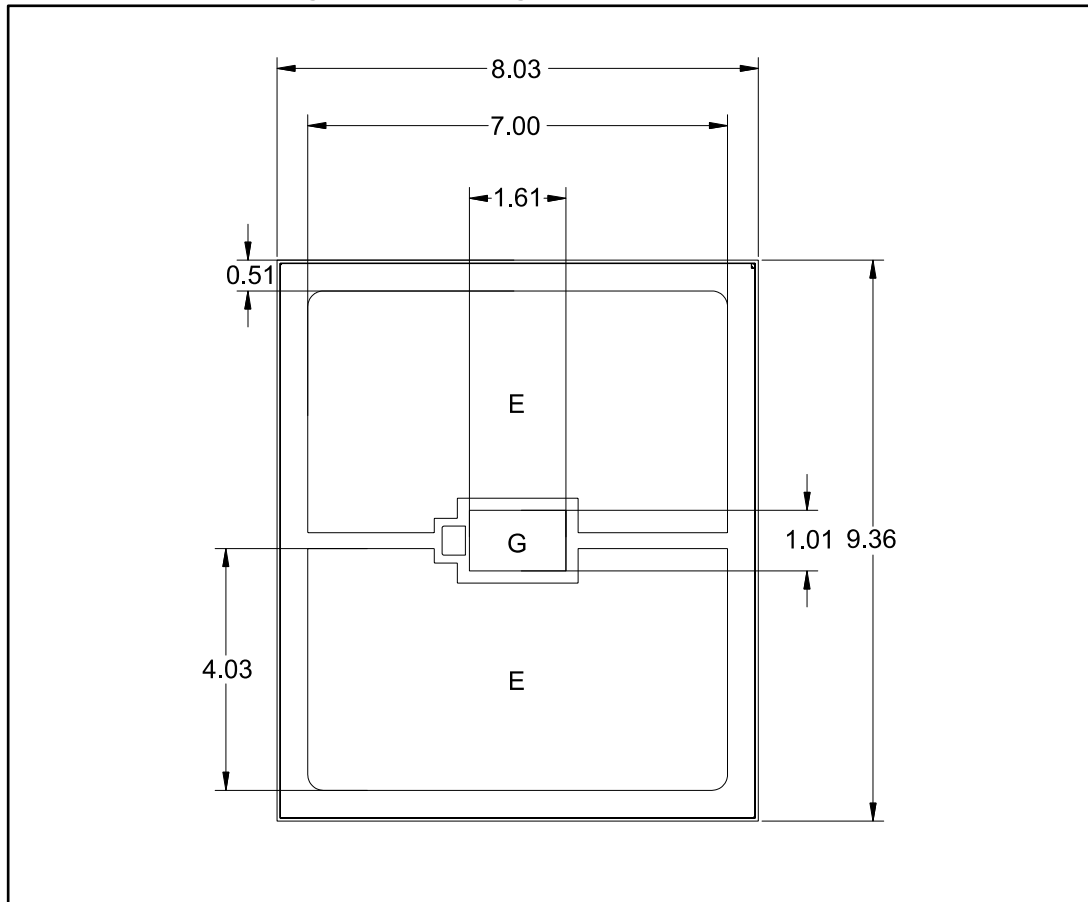
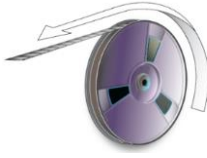

Table 7: Die delivery

Package option	Test condition	Picture
D8	The 8 inches wafer is tested, inked and cut: the dice are picked up and submitted to automatic visual inspection on the back side. The dice are tested and submitted again to visual inspection on both top and back sides. Finally, the dice are placed into a reel pocket, submitted again to a top side visual inspection and sealed with a cover tape.	

4 Additional information

4.1 Additional testing and screening

For customers requiring product supplied as known good die (KGD) or requiring specific die level testing (i.e. for dynamic and switching characterization), please contact the local ST sales office.

If KGD is requested, the shipping delivery is D8.

4.2 Shipping

Several shipping options are offered, consult the local ST sales office for availability:

- Die on film sticky foil - suffix on sales type D7
- Carrier tape - suffix on sales type D8

4.3 Handling

- Products must be handled only at ESD safe workstations. Standard ESD precautions and safe work environments are as defined in MIL-HDBK-263.
- Products must be handled only in a class 1000 or better-designated clean room environment.
- Singular die are not to be handled with tweezers. A vacuum wand with a non-metallic ESD protected tip should be used.

4.4 Wafer/die storage

Once the packaging is opened, the wafer must be stored in a dry, inert atmosphere, such as nitrogen.

Optimum temperature for storage is 18 °C \pm 2 °C with as few variations as possible to avoid parasitic polymerization of the adhesive. Sawn wafers must be processed within 12 weeks after receipt by customer.

After the customer opens the package, the customer is responsible for the products.

5 Revision history

Table 8: Document revision history

Date	Revision	Changes
16-Mar-2015	1	Initial release
12-Sep-2016	2	Updated Features. Updated <i>Table 3: Absolute maximum ratings ($T_J = 25\text{ °C}$, unless otherwise specified)</i> , <i>Table 4: Static characteristics (tested on wafer unless otherwise specified)</i> and <i>Table 5: Electrical characteristics</i> . Updated <i>Section 4.4: Wafer/die storage</i> . Minor text changes
30-Mar-2017	3	Datasheet status promoted from preliminary to production data. Updated title, features, description and applications on cover page. Updated <i>Section 1: "Mechanical parameters"</i> , <i>Section 2: "Electrical ratings"</i> and <i>Figure 1: "Die drawing (dimensions are in mm)"</i> . Minor text changes

IMPORTANT NOTICE – PLEASE READ CAREFULLY

STMicroelectronics NV and its subsidiaries ("ST") reserve the right to make changes, corrections, enhancements, modifications, and improvements to ST products and/or to this document at any time without notice. Purchasers should obtain the latest relevant information on ST products before placing orders. ST products are sold pursuant to ST's terms and conditions of sale in place at the time of order acknowledgement.

Purchasers are solely responsible for the choice, selection, and use of ST products and ST assumes no liability for application assistance or the design of Purchasers' products.

No license, express or implied, to any intellectual property right is granted by ST herein.

Resale of ST products with provisions different from the information set forth herein shall void any warranty granted by ST for such product.

ST and the ST logo are trademarks of ST. All other product or service names are the property of their respective owners.

Information in this document supersedes and replaces information previously supplied in any prior versions of this document.

© 2017 STMicroelectronics – All rights reserved