

Smart voltage supervisor

Not recommended for new design

Features

- Operating voltage 2.7 V to 5.5 V
- Supply current of 1.5 μ A (typ)
- Factory-trimmed voltage threshold from 3.2 V to 3.5 V in 50 mV increments
- 3% voltage threshold accuracy across temperature
- Enable and inhibit inputs (EN, INH)
- Power supply transient immunity
- Current limited output of 15 mA (max)
- Available in Flip Chip 8-bump package
- Operating temperature $-30\text{ }^{\circ}\text{C}$ to $+85\text{ }^{\circ}\text{C}$

Applications

- Portable devices
- Cell phones/smart phones
- PDA
- Palmtops
- Organizers
- Portable audio/video players
- Portable terminals



Contents

1	Description	5
2	Operation	8
2.1	Output, OUT	8
2.2	Enable input, EN	8
2.3	Inhibit input, INH	8
2.4	Pass gate, PKX and POX	8
3	Typical operating characteristics	10
4	Maximum ratings	13
5	DC and AC characteristics	14
6	Package mechanical data	17
7	Part numbering	19
8	Package marking information	20
9	Revision history	21

List of tables

Table 1.	Pin descriptions	5
Table 2.	Truth table for output, OUT.	8
Table 3.	Truth table for pass gate between PKX and POX	9
Table 4.	Absolute maximum ratings	13
Table 5.	Operating and AC measurement conditions.	14
Table 6.	DC and AC characteristics	15
Table 7.	Flip Chip 8-bump, package mechanical data	18
Table 8.	Ordering information scheme	19
Table 9.	Factory-trimmed thresholds with marking description.	20
Table 10.	Document revision history	21

Obsolete Product(s) - Obsolete Product(s)

List of figures

Figure 1.	Logic diagram	5
Figure 2.	8-bump Flip Chip connections	6
Figure 3.	Block diagram	6
Figure 4.	Hardware hookup	7
Figure 5.	Supply current vs. supply voltage, $V_{EN} = 4\text{ V}$	10
Figure 6.	Supply current vs. temperature, $V_{EN} = 4\text{ V}$	10
Figure 7.	Supply current vs. supply voltage, $V_{EN} = 0\text{ V}$	11
Figure 8.	Supply current vs. temperature, $V_{EN} = 0\text{ V}$	11
Figure 9.	Rising voltage detector threshold vs. temperature	12
Figure 10.	Threshold hysteresis vs. temperature	12
Figure 11.	Waveforms	14
Figure 12.	Flip Chip 8-bump, package mechanical outline	17
Figure 13.	Flip Chip tape and reel specifications	18

1 Description

STM1068 device monitors supply voltage V_{CC} and the state of EN and INH inputs. Depending on logical combination of these inputs, the output OUT is connected to V_{IN} or GND and the pass gate between PKX and POX is either enabled or disabled (see [Table 2](#) and [Table 3](#) for more details).

The device offers several voltage thresholds, V_{TH+} (see [Table 9](#)) and it is available in miniature Flip Chip 8-bump package.

Figure 1. Logic diagram

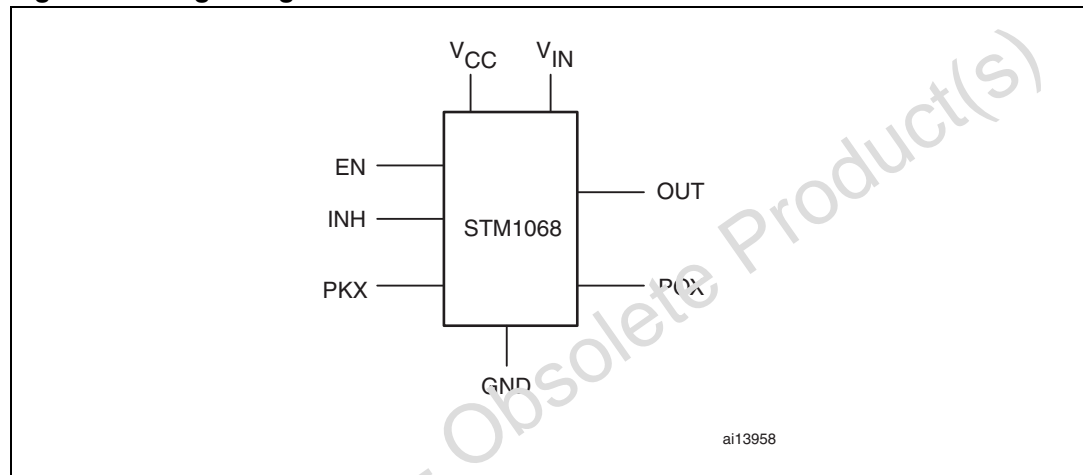

Table 1. Pin descriptions

Pin	Symbol	Function
1A	V_{IN}	Supply for output pin (OUT)
1B	EN	Enable from USB VBUS
1C	GND	Ground
1D	PKX	Pass gate input
2A	OUT	Output
2B	INH	Inhibit input
2C	V_{CC}	Supply voltage
2D	POX	Pass gate output

Figure 2. 8-bump Flip Chip connections

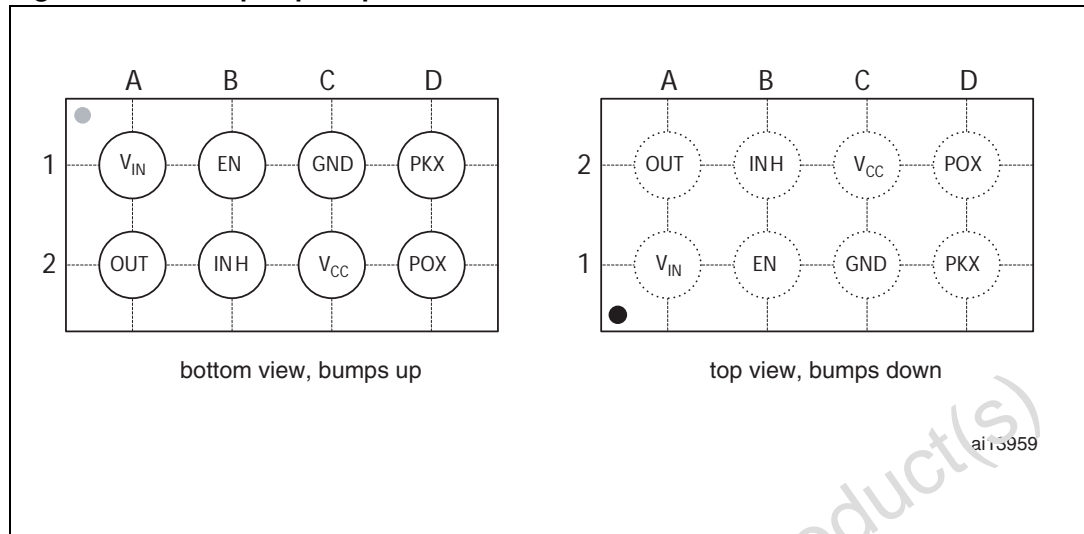

Figure 3. Block diagram

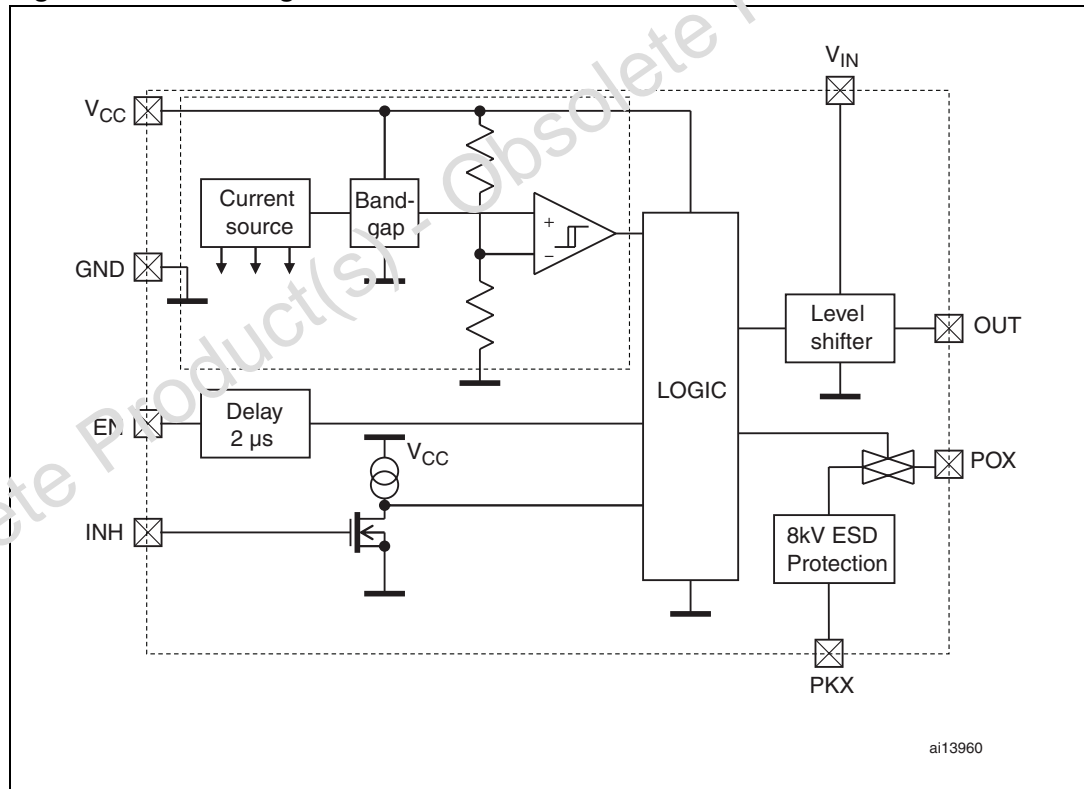
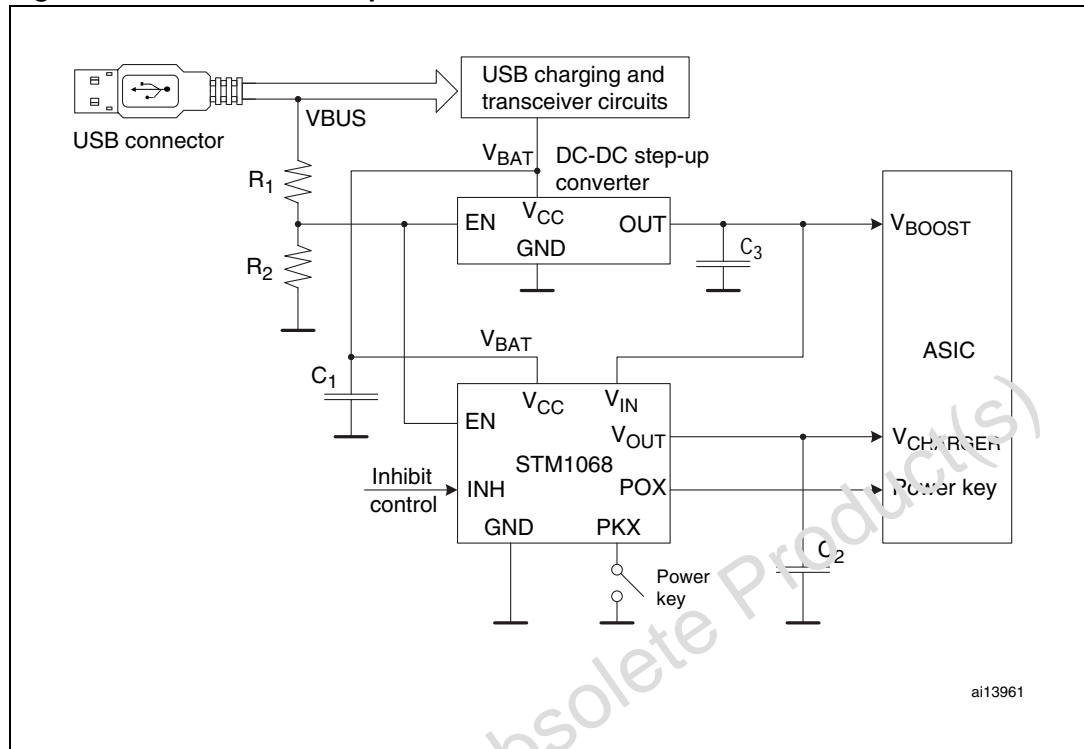

Figure 4. Hardware hookup



ai13961

Obsolete Product(s) - Obsolete Product(s)

2 Operation

The STM1068 device monitors supply voltage V_{CC} and logic states of EN and INH inputs. According to detected states is the output OUT connected to V_{IN} or GND and the pass gate between PKX and POX is either enabled or disabled (see [Table 2](#), [Table 3](#), and [Figure 11](#) for more details).

2.1 Output, OUT

If the enable input is in a logic high state and inhibit input is in a logic low state, the output will be connected to V_{IN} input as V_{CC} rises above the V_{TH+} voltage threshold. Otherwise, the output is connected to ground GND. The output is current limited (see [Table 6](#)).

2.2 Enable input, EN

A logic low on the enable input disconnects the output, OUT, from V_{IN} , the POX will follow the PKX and the device enters a standby mode with very low current consumption (see [Table 6](#)).

2.3 Inhibit input, INH

A logic high on the inhibit input disconnects the output, OUT, from V_{IN} and the POX will follow the PKX.

2.4 Pass gate, PKX and POX

Pass gate between PKX and POX is disabled only if enable input is in logic high, inhibit input is in logic low and the supply voltage is below the voltage threshold.

Table 2. Truth table for output, OUT

EN ⁽¹⁾	INH	V_{CC}	OUT
L	x	x	connected to GND
x	H	x	connected to GND
x	x	< V_{TH+} (rising edge) < V_{TH-} (falling edge)	connected to GND
H	L	> V_{TH+} (rising edge) > V_{TH-} (falling edge)	connected to V_{IN}

1. Once the device is disabled by EN input, the V_{CC} must be above V_{TH+} to reconnect output to V_{IN} .

Table 3. Truth table for pass gate between PKX and POX

EN	INH	V _{CC}	POX
L	x	x	follows PKX
x	H	x	follows PKX
x	x	>V _{TH+} (rising edge) >V _{TH-} (falling edge)	follows PKX
H	L	<V _{TH+} (rising edge) <V _{TH-} (falling edge)	open

Note: Table valid for V_{CC} > 2.7 V.

Obsolete Product(s) - Obsolete Product(s)

3 Typical operating characteristics

Figure 5. Supply current vs. supply voltage, $V_{EN} = 4\text{ V}$

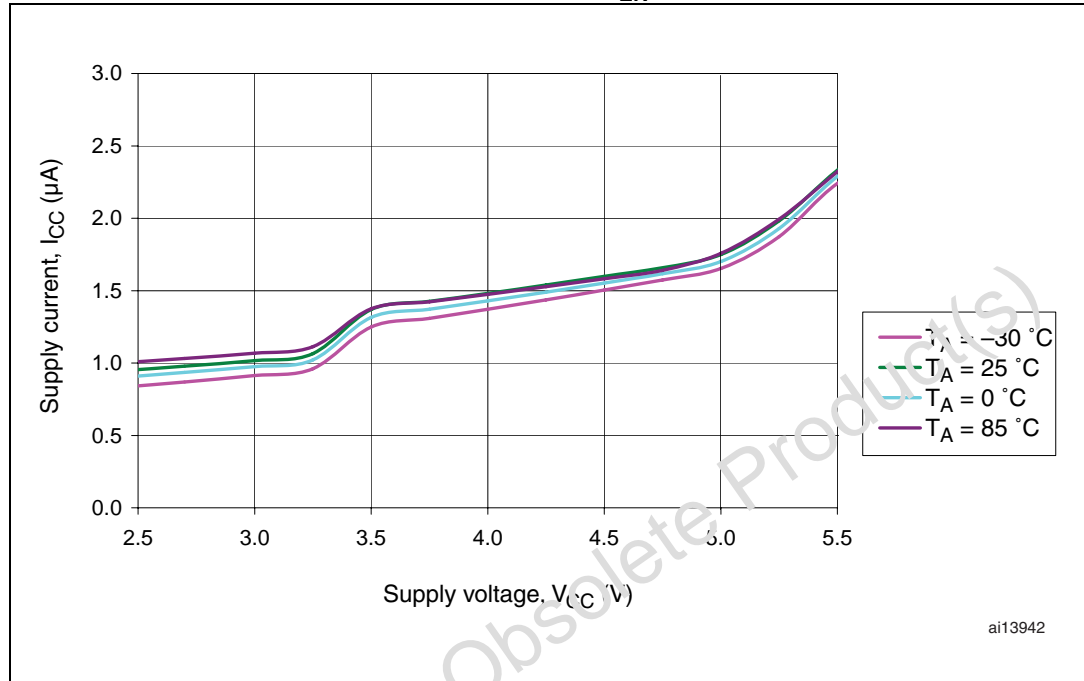

Figure 6. Supply current vs. temperature, $V_{EN} = 4\text{ V}$

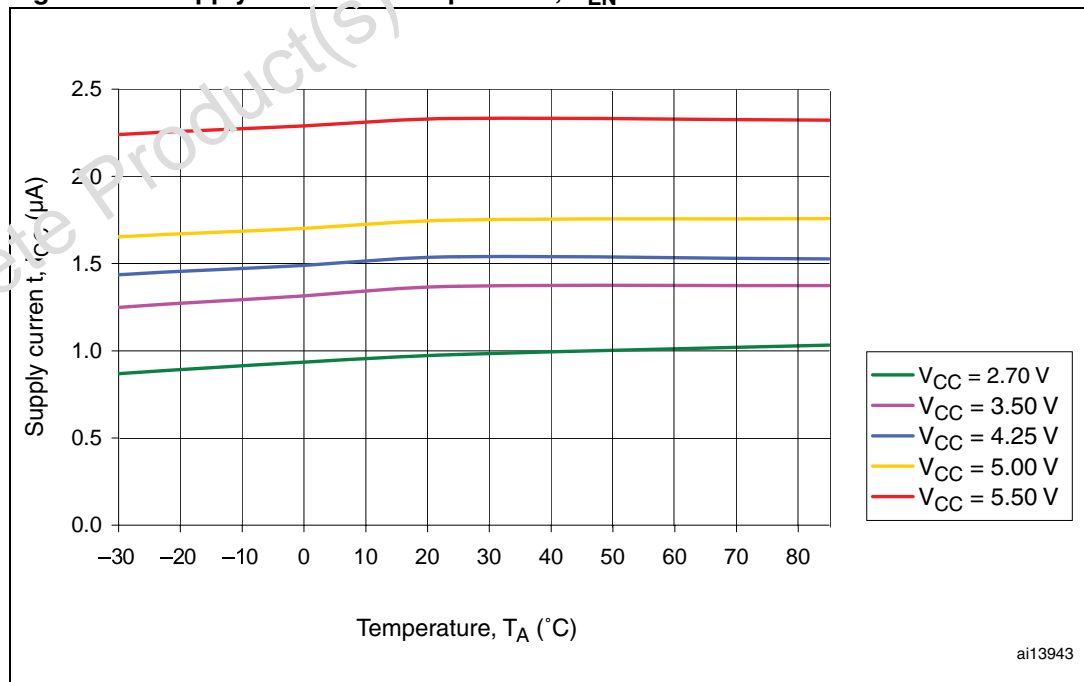

Figure 7. Supply current vs. supply voltage, $V_{EN} = 0\text{ V}$

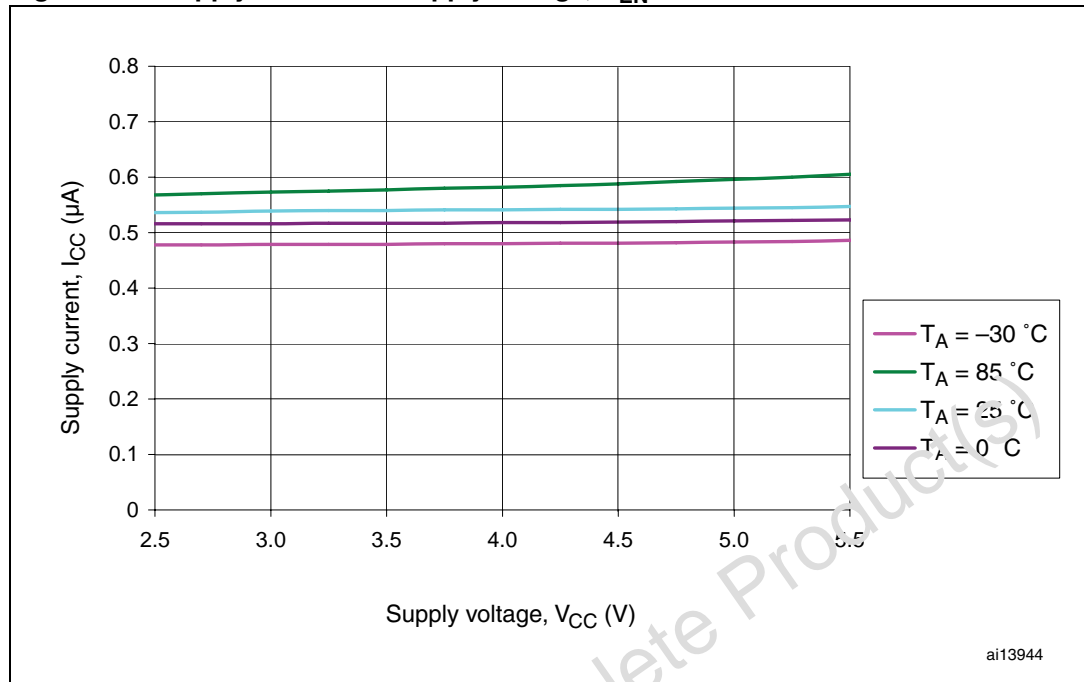

Figure 8. Supply current vs. temperature, $V_{EN} = 0\text{ V}$

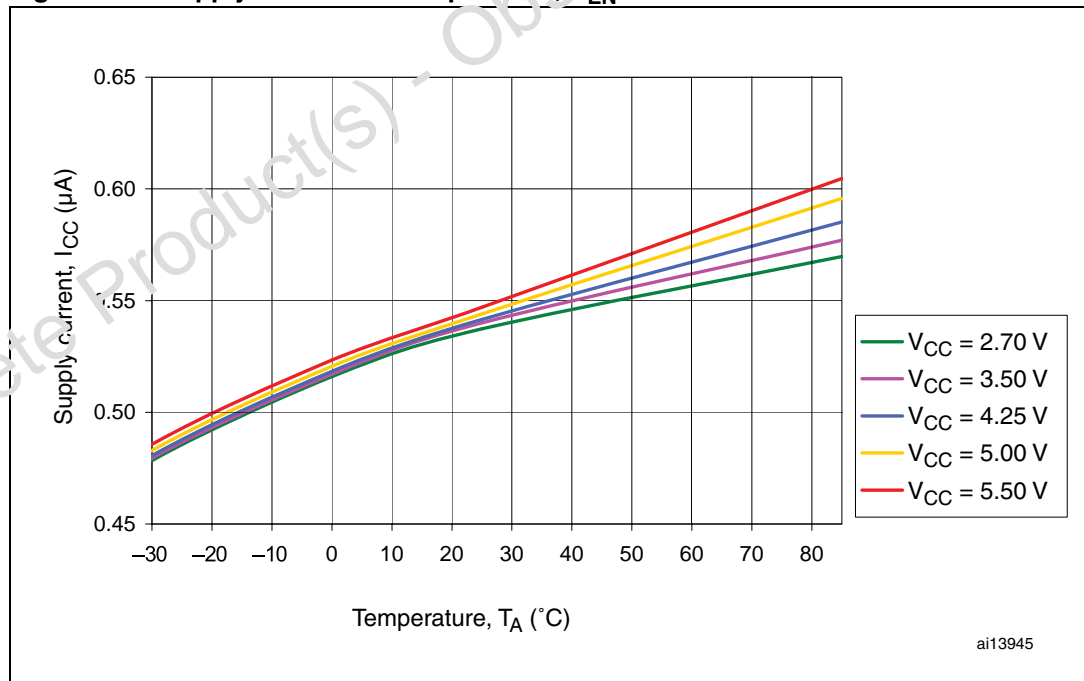

Figure 9. Rising voltage detector threshold vs. temperature

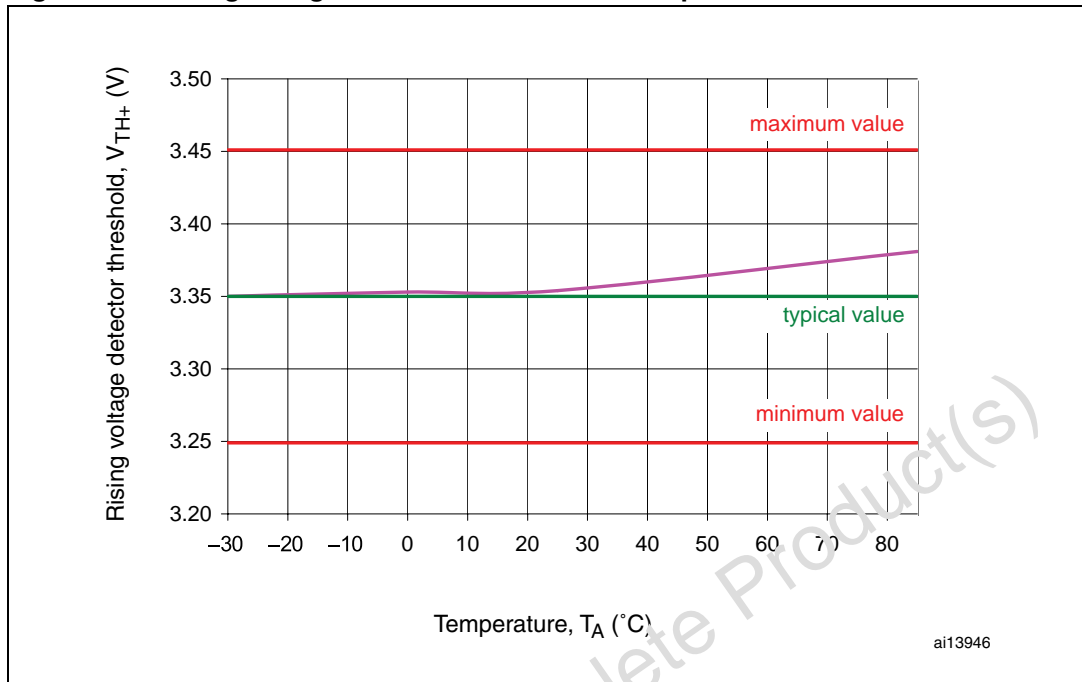
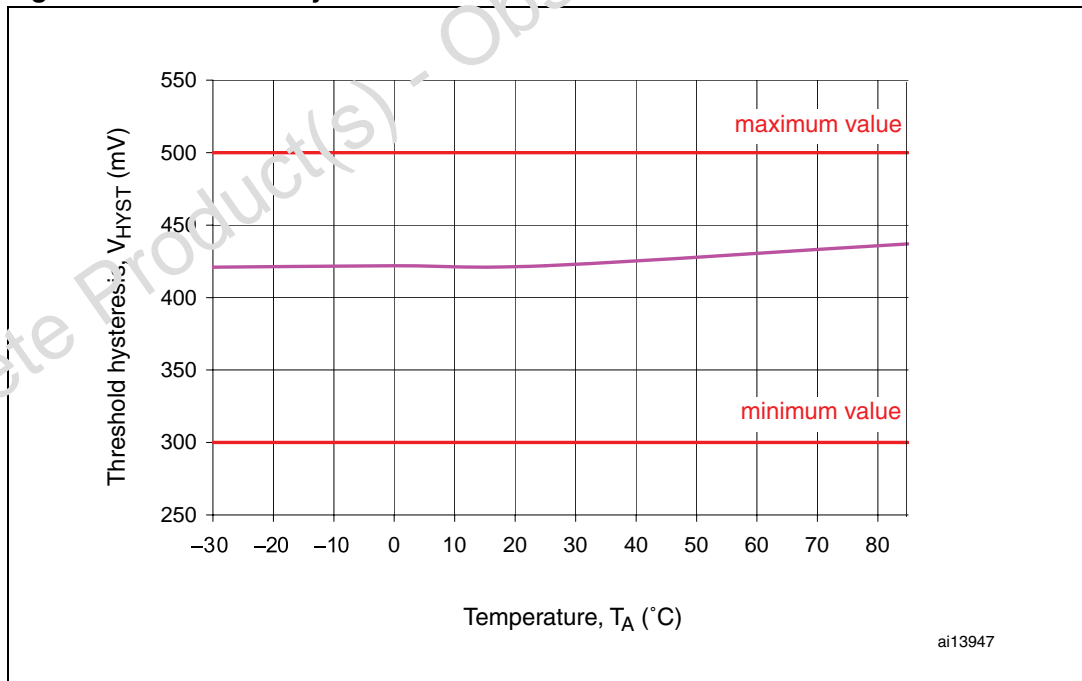

Figure 10. Threshold hysteresis vs. temperature



4 Maximum ratings

Stressing the device above the rating listed in the “Absolute maximum ratings” table may cause permanent damage to the device. These are stress ratings only and operation of the device at these or any other conditions above those indicated in the Operating sections of this specification is not implied. Exposure to absolute maximum rating conditions for extended periods may affect device reliability. Refer also to the STMicroelectronics SURE Program and other relevant quality documents.

Table 4. Absolute maximum ratings

Symbol	Parameter	Min	Typ	Max	Unit	Remarks
V_{CC}	Supply voltage	-0.2		+7.0	V	
V_{IN}	Output source voltage	-0.2		+7.0	V	Independent of V_{CC}
V_{EN}	VBUS input	-0.2		$V_{CC} + 0.3$	V	Series 1M external resistor for protection
V_{OUT}	Output pin	-0.3		$V_{IN} + 0.3$	V	
V_{INH}	Inhibit pin	-0.3		$V_{CC} + 0.3$	V	
V_{ESD}	Electrostatic protection	-2		+2	kV	Human body model (all pins)
		-8		+8	kV	Human body model (PKX only)
V_{ESD}	Electrostatic protection	-500		+500	V	Charged device model
V_{ESD}	Electrostatic protection	-100		+100	V	Machine model
V_{ESD}	Point discharge on PKX key	-8		+8	kV	IEC61000-4-2
V_{ESD}	Air discharge on PKX key	-15		+15	kV	IEC61000-4-2
T_A	Operating ambient temperature	-30		+85	°C	
	Storage temperature	-45		+150	°C	

5 DC and AC characteristics

This section summarizes the operating measurement conditions and the DC and AC characteristics of the device. The parameters in the DC and AC characteristics tables that follow are derived from tests performed under the measurement conditions summarized in [Table 5: Operating and AC measurement conditions](#). Designers should check that the operating conditions in their circuit match the operating conditions when relying on the quoted parameters.

Table 5. Operating and AC measurement conditions

Parameter	Condition	Unit
V _{CC} supply voltage	2.7 to 5.5	V
Ambient operating temperature (T _A)	-30 to 85	°C
Input rise and fall times	≤ 5	ns

Figure 11. Waveforms

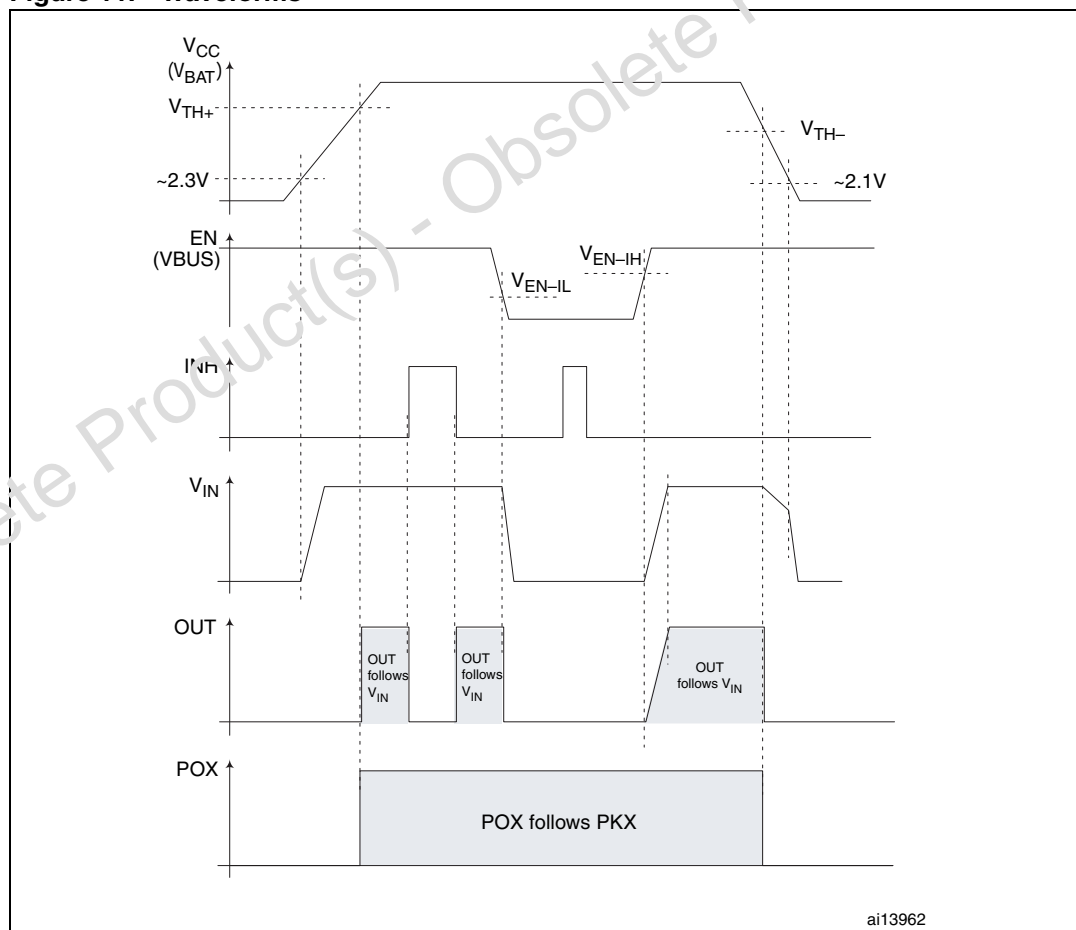

Note: V_{IN} assumed to be from 1.65 V to 5.5 V. No V_{IN} means no signal on OUT pin. If there is no V_{CC} then there will be no V_{IN}.

Table 6. DC and AC characteristics

Sym	Parameter	Test condition ⁽¹⁾	Min	Typ	Max	Unit
V _{CC}	Supply voltage		2.7		5.5	V
I _{CC}	Supply current into V _{CC} pin	V _{EN} = 0 V		0.6	1	μA
		V _{EN} = 4 V		1.5	15	μA
I _{CC} + I _{IN}	Current into V _{CC} + V _{IN} pins	V _{EN} = 0 V			5	μA
		V _{EN} = 4 V			15	μA
V _{TH+}	Rising voltage detector threshold (see Table 8 on page 19 for detailed listing)		-3%	V _{TH+}	+3%	V
V _{HYST}	Threshold hysteresis		0.3		0.5	V
V _{TH-}	Falling voltage detector threshold			V _{TH+} - V _{HYST}		V
t _{PD-FALL} ⁽²⁾	V _{CC} falling to OUT delay	V _{CC} falling from (V _{TH-} + 100 mV) to (V _{TH-} - 100 mV) at 10 mV/μs		30		μs
t _{PD-RISE} ⁽²⁾	V _{CC} rising to OUT delay	V _{CC} rising from (V _{TH+} - 100 mV) to (V _{TH+} + 100 mV) at 10 mV/μs		70		μs
V _{IN}	Voltage on V _{IN} pin Supply for output pin	Allows 2.5 V rail, V _{BAT} or +5 V	2.4		5.5	V
Output pin, OUT⁽³⁾						
V _{OUT-OH}	Output high voltage	I _{SOURCE} = 5 mA	V _{IN} - 0.2		V _{IN}	V
V _{OUT-OL}	Output low voltage	I _{SINK} = 10 mA			0.3	V
I _{OUT}	Output current		5		15	mA
Enable input, EN						
V _{EN-IH}	When VBUS is valid		1.2			V
V _{EN-IL}	When VBUS is not valid				0.4	V
I _{EN-IN}	Enable input current				0.1	μA
	EN glitch immunity		1			μs
Inhibit input, INH						
V _{INH-IH}	Inhibit logic high		1.2			V
V _{INH-IL}	Inhibit logic low				0.4	V
V _{INH-IN}	Inhibit input current				0.1	μA
	INH glitch immunity		1			μs

Table 6. DC and AC characteristics (continued)

Sym	Parameter	Test condition ⁽¹⁾	Min	Typ	Max	Unit
Pass gate between PKX and POX						
R _{DS(on)}	Static pass gate on resistance			300		Ω

1. Valid for ambient operating temperature: T_A = -30 °C to +85 °C; V_{CC} = 2.7 V to 5.5 V (except where noted).
2. Guaranteed by design.
3. For V_{CC} below V_{THL}, the output remains low down to V_{CC} = 1 V. Below V_{CC} = 1 V the voltage V_{IN} must be less than V_{OUT-OL} (max.) to guarantee output low voltage less than 0.3 V.

Obsolete Product(s) - Obsolete Product(s)

6 Package mechanical data

In order to meet environmental requirements, ST offers these devices in different grades of ECOPACK® packages, depending on their level of environmental compliance. ECOPACK® specifications, grade definitions and product status are available at: www.st.com. ECOPACK® is an ST trademark.

Figure 12. Flip Chip 8-bump, package mechanical outline

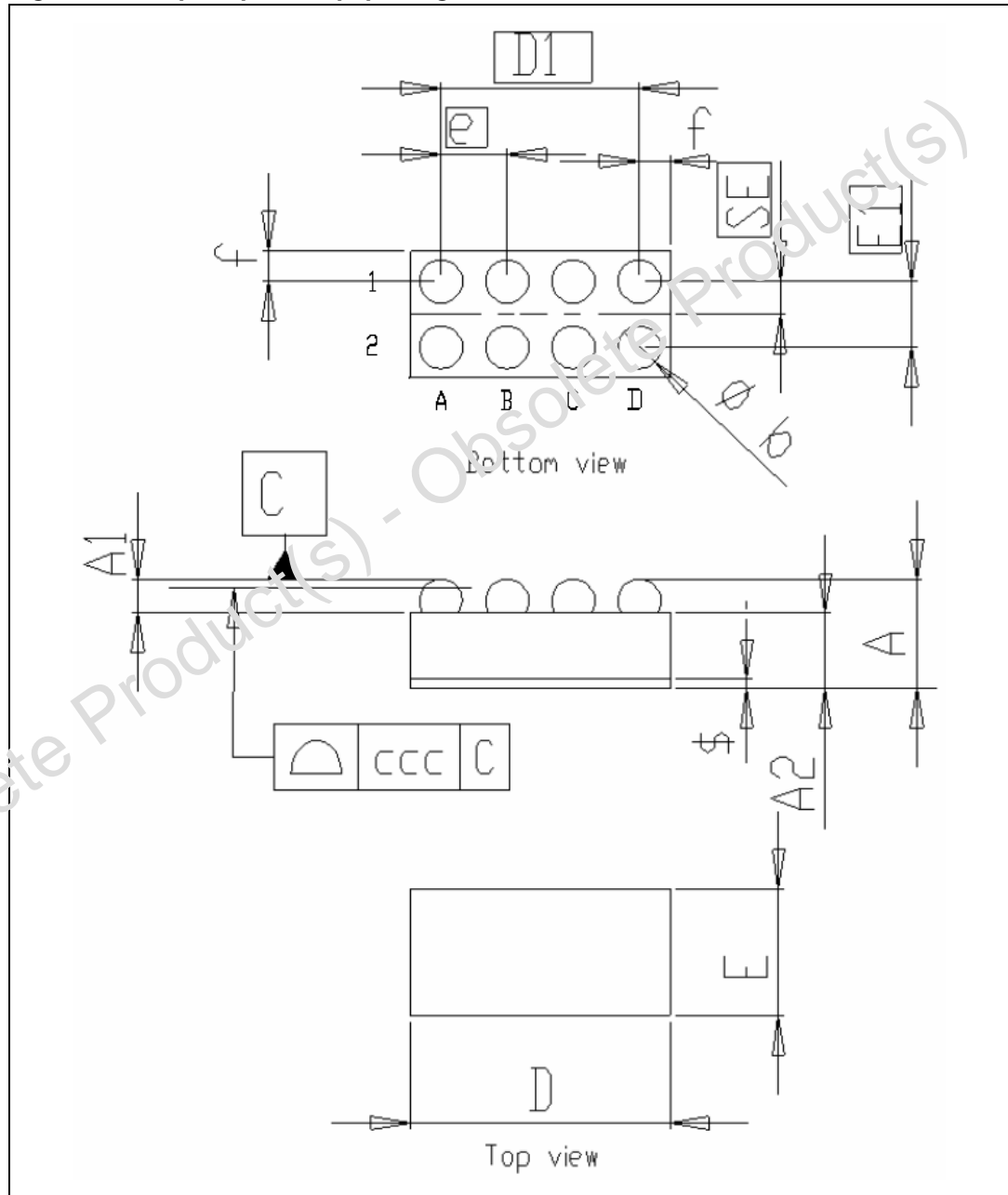

Figure 13. Flip Chip tape and reel specifications

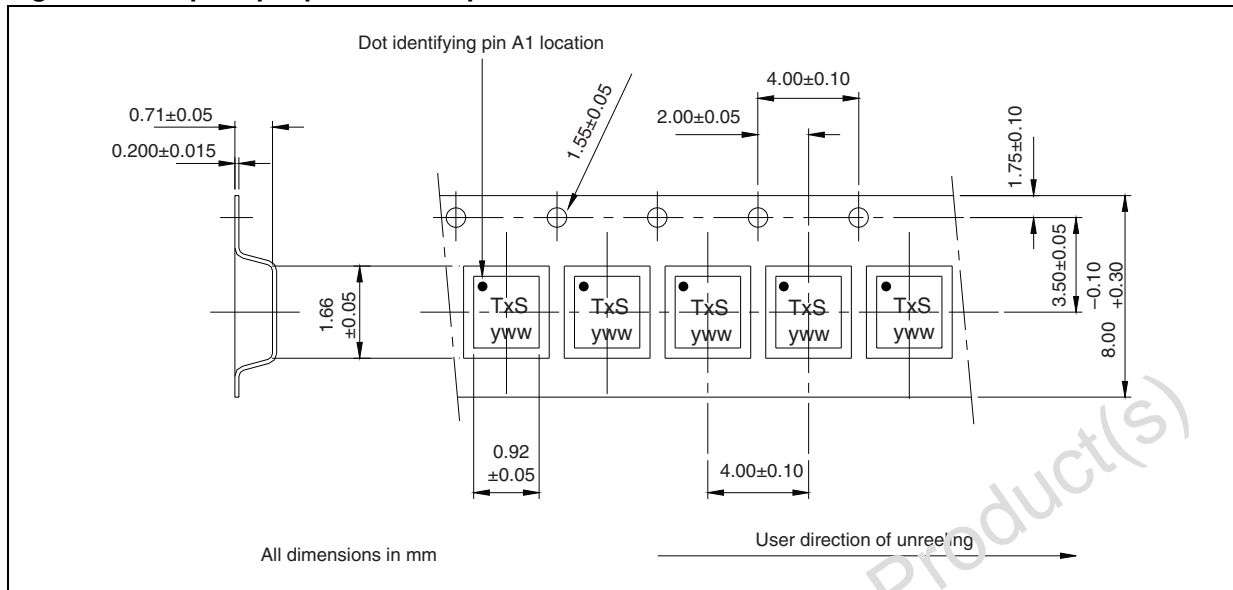

Table 7. Flip chip 8-bump, package mechanical data

Symbol	mm			inches		
	Min	Typ	Max	Min	Typ	Max
A	0.54	0.60	0.66	0.021	0.024	0.026
A1	0.170	0.205	0.240	0.007	0.008	0.009
A2		0.395			0.015	
b	0.215	0.255	0.295	0.008	0.010	0.012
D	1.570	1.600	1.605	0.062	0.063	0.063
D1		1.20			0.047	
e	0.35	0.40	0.44	0.014	0.016	0.017
E	0.77	0.80	0.83	0.030	0.031	0.033
E1	0.36	0.40	0.44	0.014	0.016	0.017
SE	0.18	0.20	0.22	0.007	0.008	0.009
f		0.20			0.008	
ccc		0.05			0.002	
\$	0.035	0.045	0.050	0.001	0.002	0.002

7 Part numbering

Table 8. Ordering information scheme

Example:	STM1068	C35	F3	8	F
Device type					
STM1068					
Threshold voltage (3.2 V to 3.5 V in 0.05 V increments)					
C20: 3.20 V ⁽¹⁾					
C25: 3.25 V ⁽¹⁾					
C30: 3.30 V ⁽¹⁾					
C35: 3.35 V ⁽²⁾					
C40: 3.40 V ⁽¹⁾					
C45: 3.45 V ⁽¹⁾					
C50: 3.50 V ⁽¹⁾					
Package					
F3: Flip Chip, lead-free, pitch = 400 μm, bump = 250 μm, 8-bump					
Temperature range					
8: -30 °C to 85 °C					
Shipping method					
F = ECOPACK [®] package, tape and reel					

1. Contact local ST sales office for availability.
2. Not recommended for new design. Contact local ST sales office for availability.

8 Package marking information

Table 9. Factory-trimmed thresholds with marking description

Part number	Rising voltage detector threshold V_{TH+} at ambient temperature T_A from -30 to $+85$ °C			Topside marking ⁽¹⁾
	Min (-3%)	Typ	Max (+3%)	
STM1068C20F38F	3.104	3.20	3.296	THS yww
STM1068C25F38F	3.152	3.25	3.348	TIS yww
STM1068C30F38F	3.201	3.30	3.399	TJS yww
STM1068C35F38F	3.249	3.35	3.451	TKS yww
STM1068C40F38F	3.298	3.40	3.502	TLS yww
STM1068C45F38F	3.346	3.45	3.554	TMS yww
STM1068C50F38F	3.395	3.50	3.605	TNS yww

1. Where "y" = assembly year (0 to 9) and "ww" = assembly work week (01 to 52).

9 Revision history

Table 10. Document revision history

Date	Revision	Changes
31-Aug-2007	1	Initial release.
07-Sep-2007	2	Updated cover page, Section 1: Description , Figure 3 , and Table 6 .
03-Jan-2008	3	Updated Figure 1 , 11 , 13 , and Table 3 , 5 , 6 , 9 ; added Section 3: Typical operating characteristics ; minor presentation changes.
26-Mar-2008	4	Updated Table 6 , 7 .
09-Apr-2008	5	Document status upgraded to full datasheet; updated Figure 12 .
27-May-2008	6	Minor document reformatting.
16-Mar-2010	7	Document reformatted, updated ECOPACK [®] text in Section 6 , corrected Figure 13 .
22-Sep-2010	8	Device not recommended for new design. (updated document status and Table 8).

Please Read Carefully:

Information in this document is provided solely in connection with ST products. STMicroelectronics NV and its subsidiaries ("ST") reserve the right to make changes, corrections, modifications or improvements, to this document, and the products and services described herein at any time, without notice.

All ST products are sold pursuant to ST's terms and conditions of sale.

Purchasers are solely responsible for the choice, selection and use of the ST products and services described herein, and ST assumes no liability whatsoever relating to the choice, selection or use of the ST products and services described herein.

No license, express or implied, by estoppel or otherwise, to any intellectual property rights is granted under this document. If any part of this document refers to any third party products or services it shall not be deemed a license grant by ST for the use of such third party products or services, or any intellectual property contained therein or considered as a warranty covering the use in any manner whatsoever of such third party products or services or any intellectual property contained therein.

UNLESS OTHERWISE SET FORTH IN ST'S TERMS AND CONDITIONS OF SALE ST DISCLAIMS ANY EXPRESS OR IMPLIED WARRANTY WITH RESPECT TO THE USE AND/OR SALE OF ST PRODUCTS INCLUDING WITHOUT LIMITATION IMPLIED WARRANTIES OF MERCHANTABILITY, FITNESS FOR A PARTICULAR PURPOSE (AND THEIR EQUIVALENTS UNDER THE LAWS OF ANY JURISDICTION), OR INFRINGEMENT OF ANY PATENT, COPYRIGHT OR OTHER INTELLECTUAL PROPERTY RIGHT.

UNLESS EXPRESSLY APPROVED IN WRITING BY AN AUTHORIZED ST REPRESENTATIVE, ST PRODUCTS ARE NOT RECOMMENDED, AUTHORIZED OR WARRANTED FOR USE IN MILITARY, AIR CRAFT, SPACE, LIFE SAVING, OR LIFE SUSTAINING APPLICATIONS, NOR IN PRODUCTS OR SYSTEMS WHERE FAILURE OR MALFUNCTION MAY RESULT IN PERSONAL INJURY, DEATH, OR SEVERE PROPERTY OR ENVIRONMENTAL DAMAGE. ST PRODUCTS WHICH ARE NOT SPECIFIED AS "AUTOMOTIVE GRADE" MAY ONLY BE USED IN AUTOMOTIVE APPLICATIONS AT USER'S OWN RISK.

Resale of ST products with provisions different from the statements and/or technical features set forth in this document shall immediately void any warranty granted by ST for the ST product or service described herein and shall not create or extend in any manner whatsoever, any liability of ST.

ST and the ST logo are trademarks or registered trademarks of ST in various countries.

Information in this document supersedes and replaces all information previously supplied.

The ST logo is a registered trademark of STMicroelectronics. All other names are the property of their respective owners.

© 2010 STMicroelectronics - All rights reserved

STMicroelectronics group of companies

Australia - Belgium - Brazil - Canada - China - Czech Republic - Finland - France - Germany - Hong Kong - India - Israel - Italy - Japan - Malaysia - Malta - Morocco - Philippines - Singapore - Spain - Sweden - Switzerland - United Kingdom - United States of America

www.st.com