

# STDRIVEG600

## GaN half-bridge driver



### More efficiency with HV high-speed half-bridge gate driver



### Single chip, half-bridge gate driver for Enhancement mode GaN FETs

The single chip, half-bridge, STDRIVEG600 gate driver is designed for specific GaN FET driving requirements, with a short 45ns propagation delay and supply voltage operation down to 5 V.

The STDRIVEG600 delivers high robustness and efficiency through high common mode transient immunity, a suite of integrated protections and optimal GaN VGS driving voltage.

This single chip with integrated bootstrap diode allows designers to implement GaN performance advantages and simplify design and bill-of-material requirements at the same time.

#### KEY FEATURES & BENEFITS

Highest robustness, efficiency and integration:

- Up to 20 V gate driver
- Voltage rail to 600 V
- 5.5 A / 6 A source/sink currents
- 45 ns short propagation delay
- Integrated bootstrap diode
- Separate ON-OFF outputs for easier tuning
- 3.3 V / 5 V logic inputs
- UVLO on Vcc and VBOOT
- Thermal shutdown
- Interlocking function
- Shut-down pin
- S016 narrow package

#### KEY APPLICATIONS

Power and energy for high efficiency applications:

- SMPS
- High voltage PFC
- Active clamp converters
- DC-DC converters
- UPS systems
- Solar power



## Going GaN with the new STDRIVEG600 driver

### Key features

The high current capability and short 45ns propagation delay render this single chip, half-bridge gate driver ideal for high-speed silicon and GaN FET.

The high-side section is suitable for applications with up to 500 V bus voltage, but can withstand up to 600 V, and dV/dt immunity of  $\pm 200\text{V/ns}$  ensuring robust STDRIVEG600 performance.

The CMOS/TTL compatible logic inputs down to 3.3 V ensure provide straightforward interfacing with microcontrollers and DSP peripherals.

The STDRIVEG600 allows optimized GaN 5V or 6V gate-source driving voltages. The integrated undervoltage lockout (UVLO) protection on both the lower and the upper driving sections prevents low efficiency operation in the power switches as well as potentially dangerous conditions.

The interlocking function avoids cross-conduction conditions, and over-temperature protection includes a thermal shutdown protection feature which turns both driver outputs low to create high impedance in the half-bridge when the junction temperature reaches a set threshold.

STDRIVEG600 natively supports source Kelvin connection on both high side and low side to further optimize GaN device gate driving.

### Product and development ecosystem availability

STDRIVEG600 is offered both in SO16 and in dice (wafer) with the STDRIVEG600W code.

Two evaluation boards are available: the EVSTDRIVEG600DG for evaluating the characteristics of STDRIVEG600 driving 650 V e-Mode GaN switches, and the EVSTDRIVEG600DM for evaluating the characteristics of STDRIVEG600 driving 600V MDmesh DM2 Power MOSFET. Both boards feature an on-board programmable dead time generator and a 3.3 V linear voltage regulator to supply external logic controllers like microcontrollers.

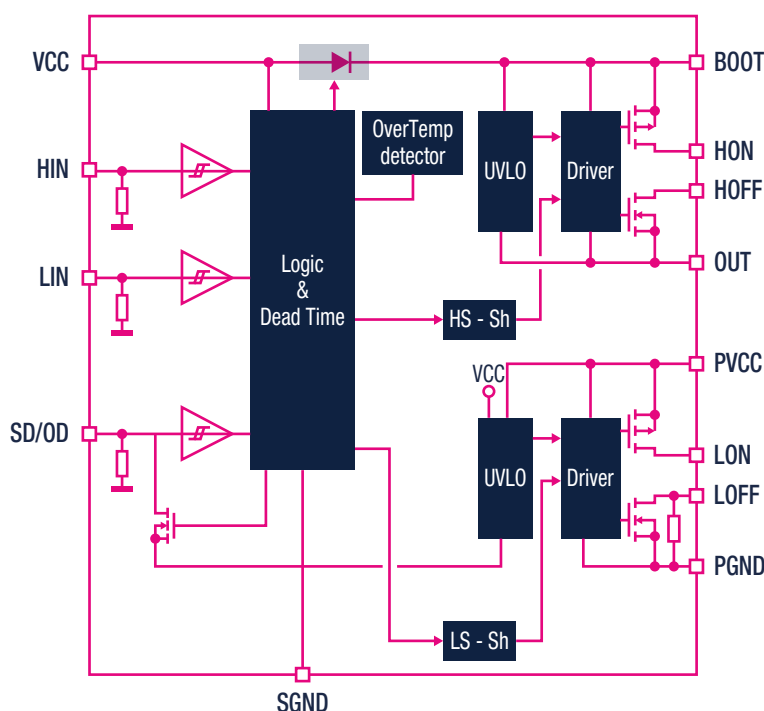

Order code	Description	Package	Packing	Evaluation boards
STDRIVEG600	High voltage and high-speed half-bridge gate driver for GaN transistors	SO-16	Tube	EVSTDRIVEG600DG; EVSTDRIVEG600DM
STDRIVEG600TR		SO-16	Tape&Real	
STDRIVEG600W		Wafer	-	



© STMicroelectronics - March 2023 - Printed in the United Kingdom - All rights reserved  
 ST and the ST logo are registered and/or unregistered trademarks of STMicroelectronics International NV or its affiliates in the EU and/or elsewhere. In particular, ST and the ST logo are Registered in the US Patent and Trademark Office.  
 For additional information about ST trademarks, please refer to [www.st.com/trademarks](http://www.st.com/trademarks).  
 All other product or service names are the property of their respective owners.

