



L99LDLH32

Smart 32-channel driver for automotive LED and OLED panels



Dynamic (O)LED controller with advanced CAN FD Light protocol for eye-catching light patterns and effects enhancing styling and safety

A linear current regulator in high-side configuration, the L99LDLH32 is ideal for use with LED and OLED up to 4096 pixels. It features 32 regulated current sources able to provide individually programmable currents to drive each pixel of the panel independently and offers global dimming with 8-bit resolution.

The integrated CAN FD Light protocol handler and transceiver eliminate the need for costly external components like timing crystals when connecting to a vehicle's communication infrastructure and domain controller ECU.

With a data bandwidth of 1Mbit/s, designers can create highly animated light patterns and smoothly modulated transitions and dimming.

KEY FEATURES

- Precision oscillator for CAN synchronization
- Innovative analog features for control and protection functions
- Programmable logic and state machine
- ASIL B "ready"

MAIN BENEFITS

- Fully scalable with flexible customization
- Ready for Over-the-Air updates
- Evaluation board (EV-L99LDLH32GEN) available

KEY APPLICATIONS

- Automotive OLED rear lighting
- Automotive exterior and interior LED lighting

The L99LDLH32 is a highly integrated device that includes all necessary functions, such as functional safety support, voltage and temperature monitors, and no false activation of light function, in addition to no light operation with low brightness. The device is packaged in a compact 48 lead QFN package (7mm x 7mm) with wettable flanks and an exposed thermal pad to aid heat dissipation, ensuring reliable and efficient operation over a wide temperature range from 40°C to 150°C. The device is designed to support ASIL requirements as per the ISO 26262 standard, with key features such as a timeout watchdog with limp-home function.

The L99LDLH32 addresses the automotive industry's new efficiency challenges with its low standby current

absorption achieved with all-channel switch-off.

The device offers a wide range of configurability options, including the ability to operate in stand-alone, fail-safe, and bus modes, as well as the integration of both volatile and non-volatile memories. The device also enhances safety through digital OLED communication and dynamic 3D effects for individualization.

The CAN FD Light interface allows for easy integration of the device into the vehicle's architecture, making it an attractive option for automotive manufacturers.

The L99LDLH32 boasts several special features that improve EMC performance, including slow turn on/off time, gradual outputs delay, and dithered clock. It also features an integrated 8-bit ADC, which enables

full and flexible diagnostic capabilities. In addition, there is one dedicated line, which is connected to a physical pin for fault bus, allowing for various kinds of fault diagnostics on the OLEDs at the output channels. These channels can be put in parallel to address higher current than the programmable one. For each channel, the current can be individually programmed by using an integrated 8 bit DAC.

To help developers get started with their designs, an evaluation board (EV L99LDLH32GEN) provides an easy way to connect the L99LDLH32 into an existing system.

Functional block diagram with smart features

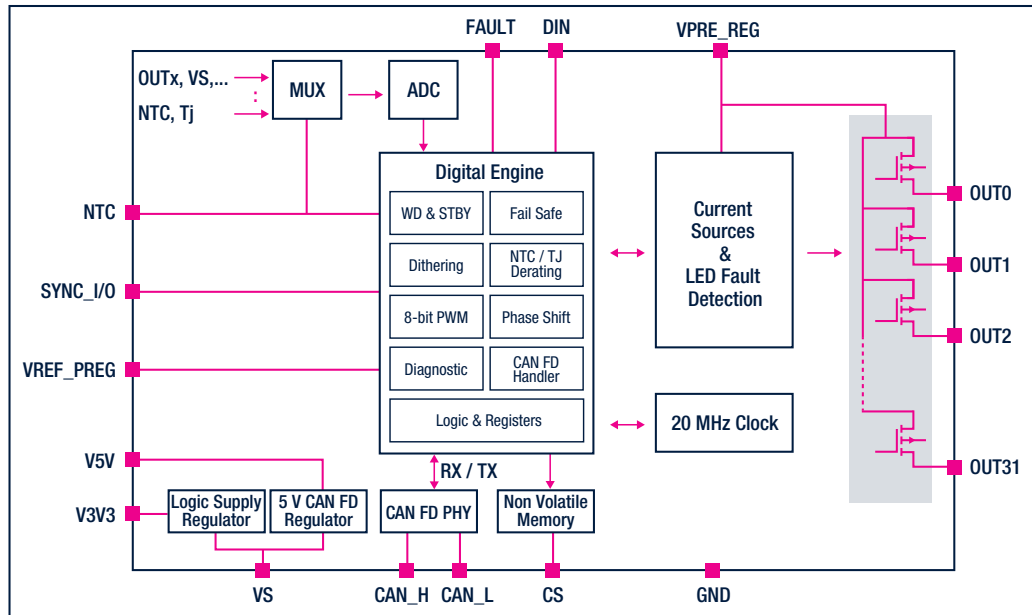

Product	Channels	Rating	Type	Operating temperature range (°C)	Channel output current (mA)	Supply voltage (V)	Output voltage (V)	Package
L99LDLH32	32	Automotive	Linear	-40 to 150	1 to 15	5.5 to 40	Up to 35	QFN48L (7mm x 7mm)



© STMicroelectronics - December 2023 - Printed in the United Kingdom - All rights reserved
 ST and the ST logo are registered and/or unregistered trademarks of STMicroelectronics International NV or its affiliates in the EU and/or elsewhere. In particular, ST and the ST logo are Registered in the US Patent and Trademark Office.
 For additional information about ST trademarks, please refer to www.st.com/trademarks.
 All other product or service names are the property of their respective owners.

