

High Efficiency Resonant Converters – MDmesh™ M6



 MDmesh™

 Resonant Converters

 MDmesh™
M6 in LLC

 SiC & GaN

Enphase Microinverter IQ7 with MDMesh™

About Enphase



New Energies World Scenario

Potential Saving

- Energy saving by means of conversion efficiency improvement is the best way to reduce power consumption and, consequently, the energy waste.



Transportation
consumes
More than

20%

of world
energy



By 2020 more
than

30
billion

Smart Things
needing power



Electric
lighting uses

20%

of global
electricity



Industry
consumes
More than

50%

of world
energy



Electric motors
use

60%

of industry
electricity



MDMesh™ Superjunction Technology

Breakdown Voltage

600V

650V

800V – 1700V

MDmesh series

M2

M6

DM2

DM6

M5

DM2

DM6

K5

Focus Applications

Flyback, PFC/LLC
resonant converter –
Charger adapters Led lighting

Flyback, PFC/LLC high efficiency
resonant converter –
Charger adapters

Half/full bridge topologies, ZVS, LLC
Solar, Server, Telecom SMPS

Half/full bridge ZVS, LLC high efficiency topologies
Solar, Server, Telecom SMPS

Hi-end-power PFC and hard switching topologies
Solar, Server, Telecom SMPS

Half/full bridge topologies, ZVS, LLC
High power level
Solar, Server, Telecom SMPS

Half/full bridge ZVS, LLC high efficiency topologies
High power level
Solar, Server, Telecom SMPS

Flyback topology
LED driver, LED lighting, auxiliary SMPS

TST leading technology for High Power PFC

Complete Product Portfolio and Wide Package Offer



Extensive product range for HV MOSFET

- *One of the industry's lowest $R_{DS(on)}$*
- *Targeted* for high efficiency in High power Applications
- *Smaller* form factor for final system
- *High* switching speed

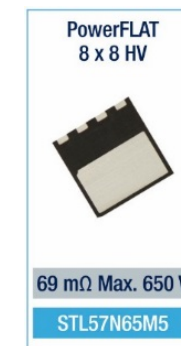
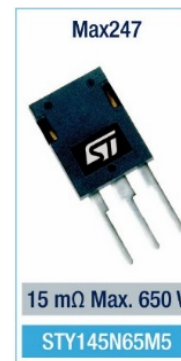

Super-Junction MOSFET family to maximize efficiency

Complete Product Portfolio and Wide Package Offer



Extensive product range for HV MOSFET

- **The most complete** series for HV MOSFET (400V – 500V – 600V – 650V)
- **Targeted** for Adapters and LLC converters
- **Good** dynamic behaviors for Soft Switching applications
- **Great** ruggedness – BtB G-S zeners

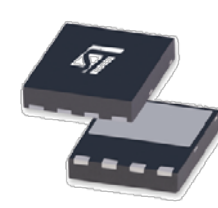
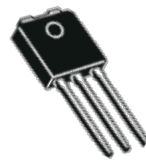

MDmesh™ M2: Targeted for RESONANT LLC Converter at 600V and 650V

Gate charge comparison™ – VDD=480V – ID=18A – Ig=1.3mA

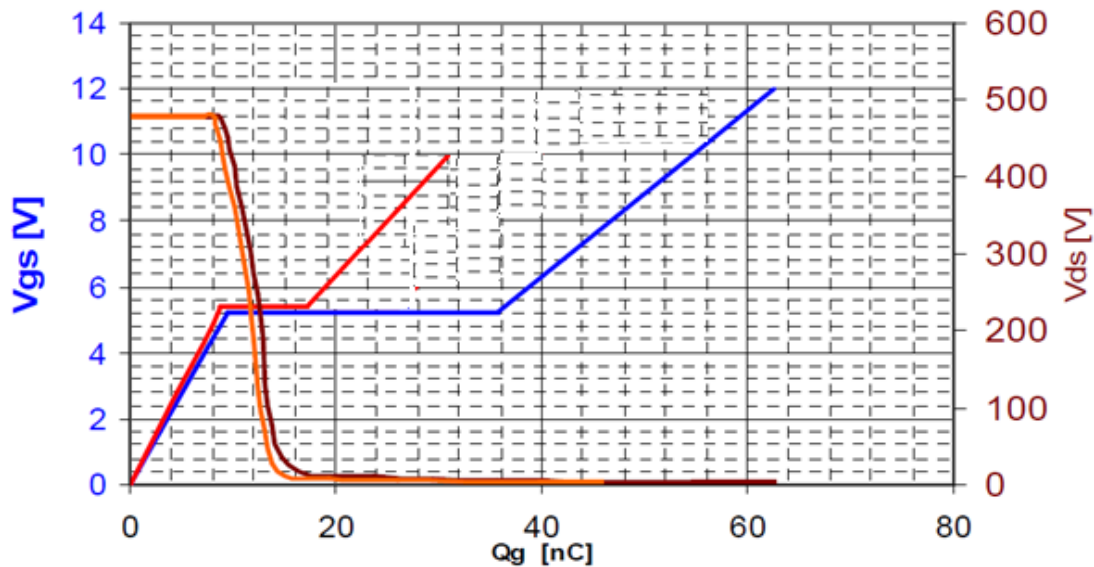

— Vgs -STD — Vgs -Low Qg
— Vds -STD — Vds-Low Qg

- Very low Gate charge and optimized capacitances profile
- Wide package option for increasing power density
- Easy to drive

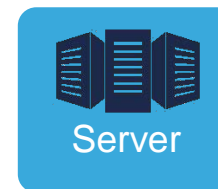

MDmesh™ DM2: Fast Recovery Diode Super-Junction MOSFET Family

Complete Product Portfolio



The FAST Solution for HV MOSFET

- ***The most complete*** series of fast diode HV MOSFET (500V - 600V - 650V)
- ***Targeted*** for ZVS & LLC Bridge topologies
- ***Improved*** intrinsic diode reverse recovery time: lower T_{rr} , Q_{rr} , I_{rrm} and better softness
- ***Higher*** dv/dt capability

MDmesh™ DM2: Fast Recovery Diode Solution for DC-DC Converter at 600V and 650V

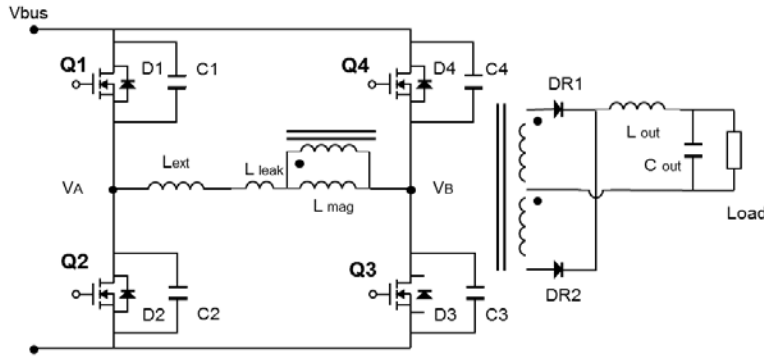

○ More design flexibility & increased power density in FB & HF

○ Higher efficiency in DC-DC converters

○ Improved system reliability

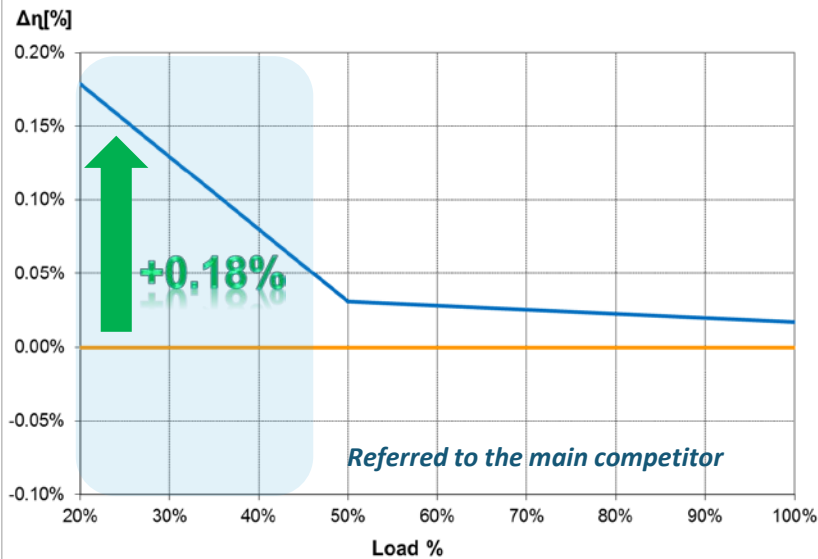

A Good Solution on Motor Control Applications

MDmesh™ DM2: Fast Recovery Diode Solution at 600V

MOSFET vs IGBT

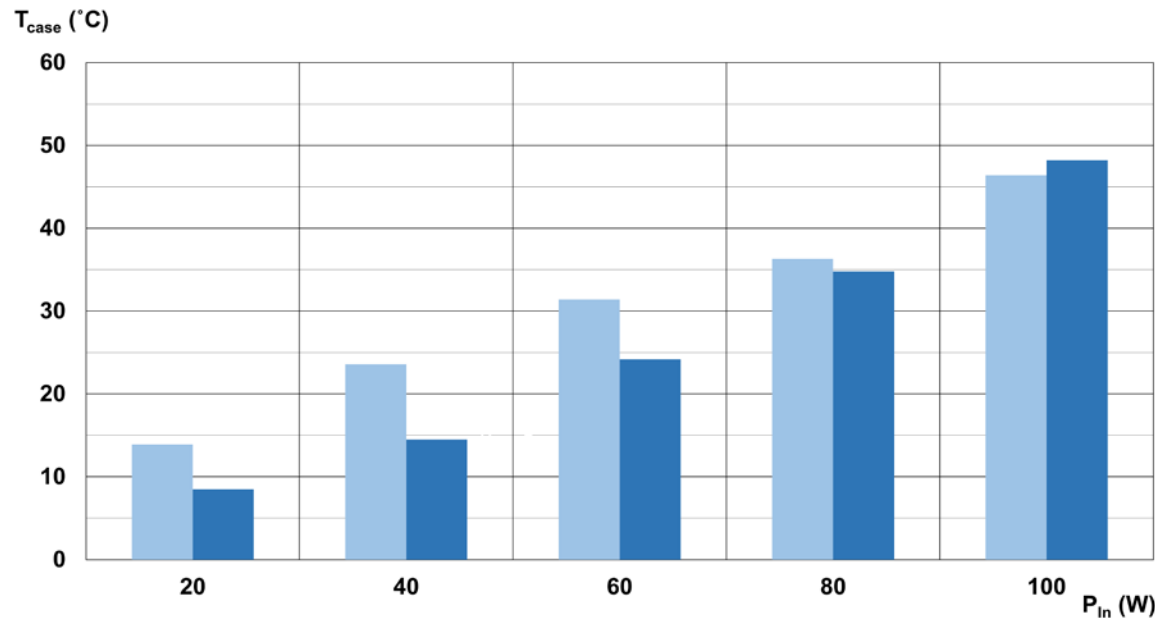

- IGBT solution
- MOSFET solution

The ideal switch to boost efficiency

- **Best** Silicon performances up to 100W
- **Enables** higher energy efficiency label on fridge Compressor
- **Multiple package options** (Discrete and Module)



The Most Complete Super-Junction MOSFET Family

Complete Product Portfolio



The ONE-STOP-SHOP for VHV MOSFET

- *The most complete* series for VHV MOSFET (from 800V till 1500V)
- *Targeted* for Flyback topologies



MDmesh™ M6:

New Super-Junction MOSFET Family

600V - 650V - 700V MDmesh™ M6: Advance in High Efficiency Topologies

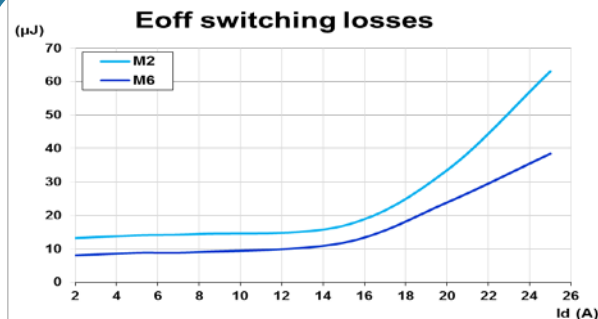

The Ideal Switch to Boost Efficiency

- **Latest** HV MOSFET (600V - 650V - 700V) series
- **Targeted** for ZVS & LLC Bridge topologies
- **Improved** Efficiency at light load conditions

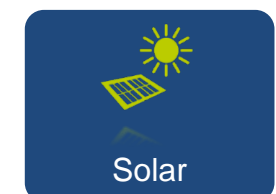

600 to 700 V MDmesh™ M6

KEY FEATURES

- Optimized threshold voltage for soft switching.
- Extremely low Qg and optimized capacitance profile for light load conditions.
- Low gate charge for operation at high frequencies

KEY BENEFITS

- Good switching behavior for hard and soft switching
- Extremely high efficiency performance to increase power density
- Targets high efficiency in new topologies for power conversion applications

KEY APPLICATIONS

- Chargers
- Adapters
- Silver box modules
- LED lighting
- Telecom
- Servers
- Solar inverters



The MDmesh™ M6 MOSFET series is today's reference for resonant topologies.

MDmesh™ M6:

Technology Features for Resonant Converters

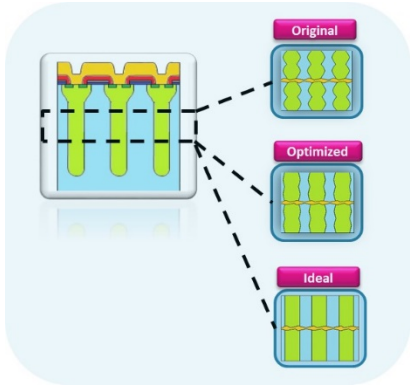

- New diffusion process and the optimization of MDmesh™ M2
- Thermal Spice model also available on web
- Optimized diffusion process to enhance the resonant converters performances



Optimized threshold voltage

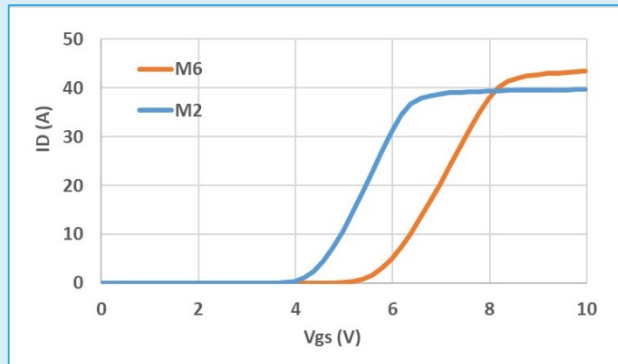

Optimized Coss

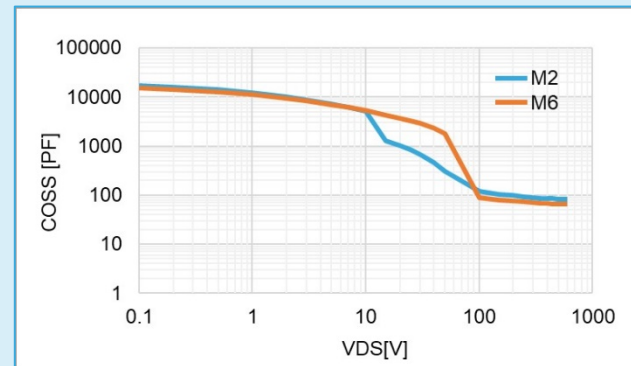

Low gate charge

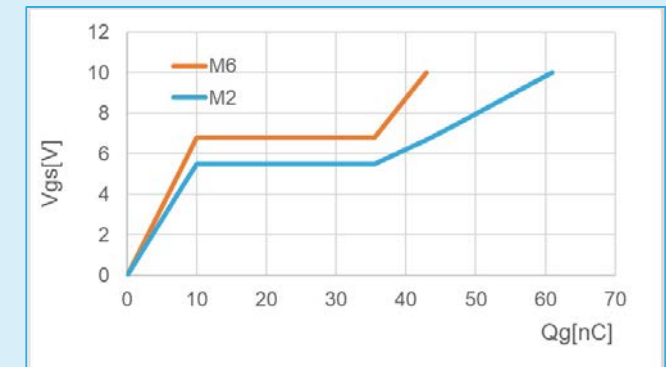

Reduced switching losses

Increase Power Efficiency at light load

High frequencies operation

Sub Topics Overview

Half Bridge LLC

Basic concepts

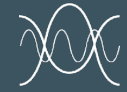

Basic functionality of a resonant LLC

MOSFET role to achieve the ZVS
Output Capacitance (C_{oss})

MOSFET role to achieve the ZVS
Body Diode

PSU during “non standard Operation”

MOSFET's key features and benefits in PSU

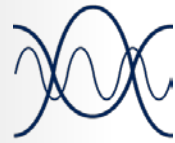

Basic Functionality of a Resonant LLC

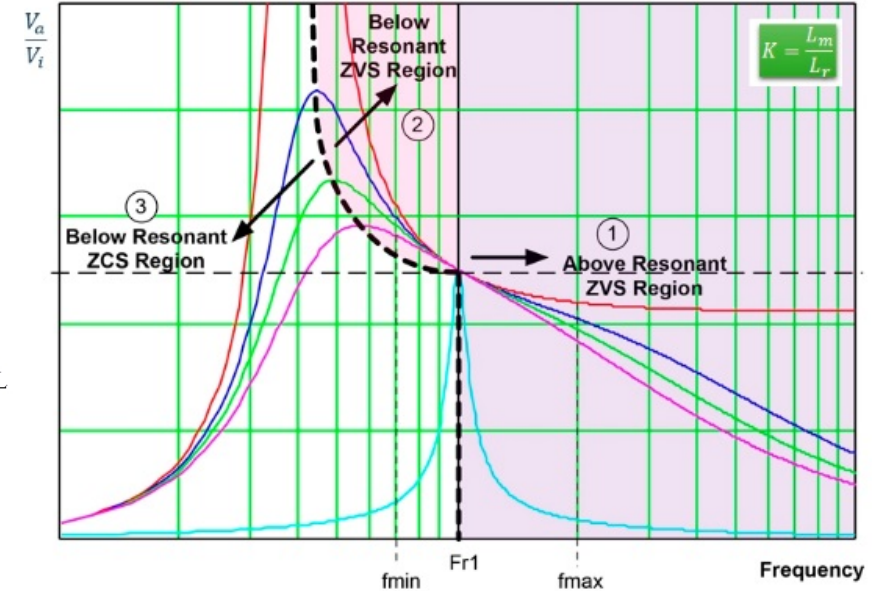
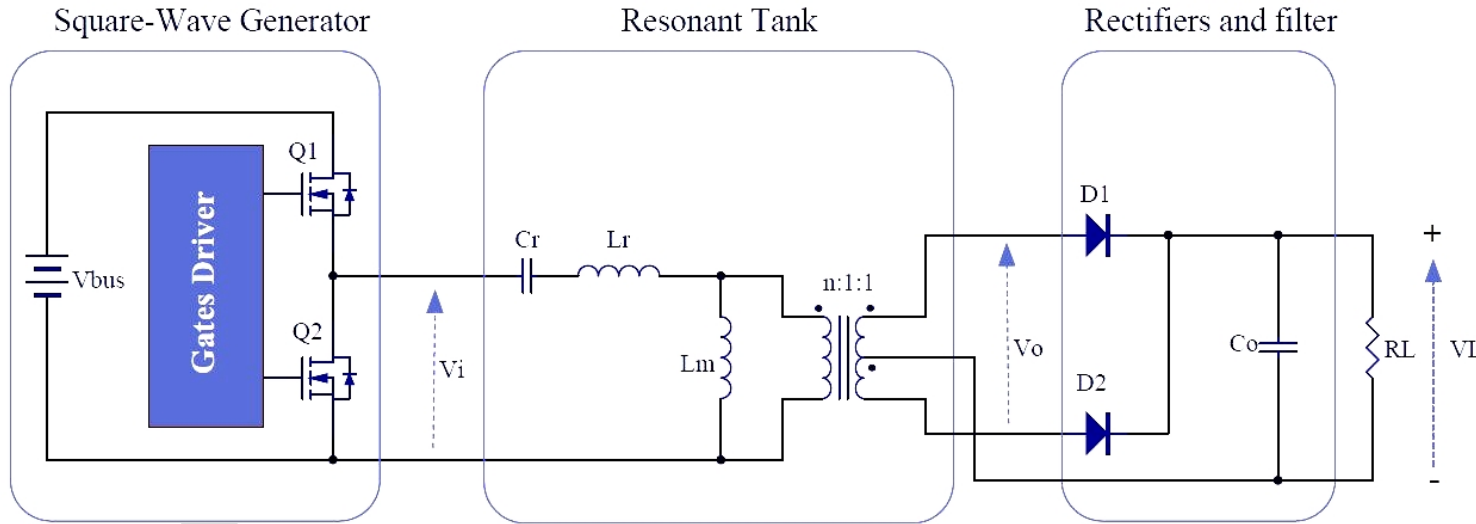

- Dead time T_D to avoid cross conduction and allow time to achieve the ZVS.
- Operation above resonance reduce the circulation current in the primary side reducing the conduction losses.

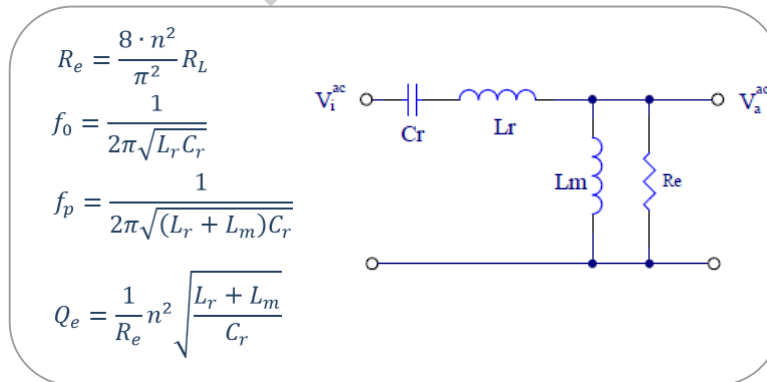
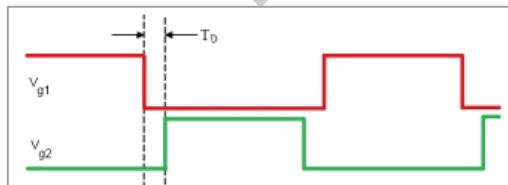

AN2644
An introduction to LLC resonant half-bridge converter

POWER MOSFET Role to Achieve the ZVS

MOSFET Output Capacitance (Coss)

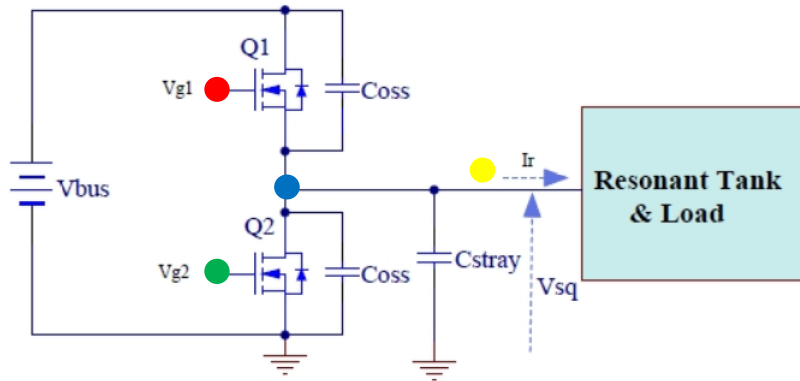

- From First Harmonics Analysis (FHA) the ZVS condition depends on the Q quality factor.
- At resonance a Tank with high loaded quality factor Q ensures a “pure” sinusoidal current.
- The Q depends on the capacitance C_{OSS} and C_{stray} at the middle point HB node.

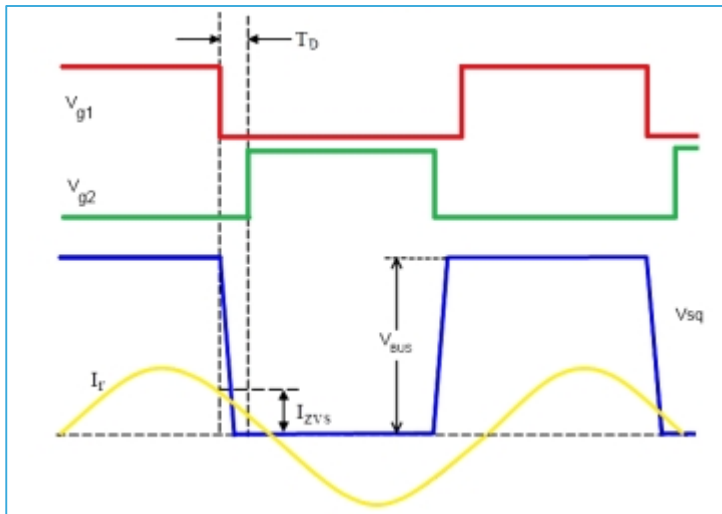

$$I_{zvs} = (2C_{oss} + C_{stray}) \frac{V_{BUS}}{T_D}$$

Q for ZVS must satisfy the two extreme combinations in-out:

- Full load and min V_{in}
- No load and max V_{in}

MOSFET C_{oss} is very important in resonant converters

MOSFET Role to Achieve the ZVS

MOSFET Body Diode

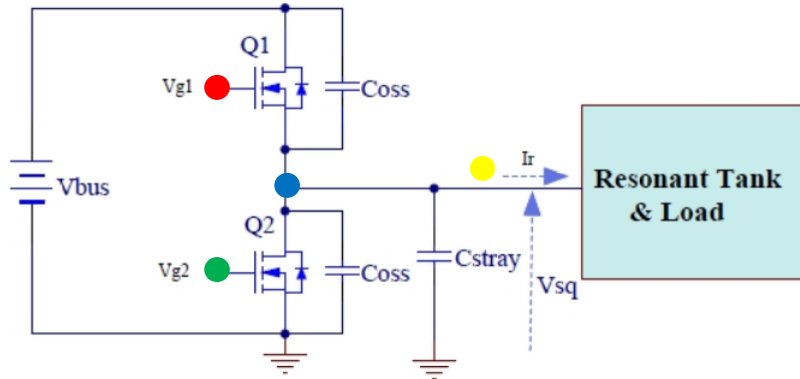

- During the dead-time the current flow through the body diode of the each MOSFET to guarantee ZVS operation while during the ON state the body diode is OFF.
- MOSFET Body diode must withstand reverse recovery dV/dt during the normal operation.

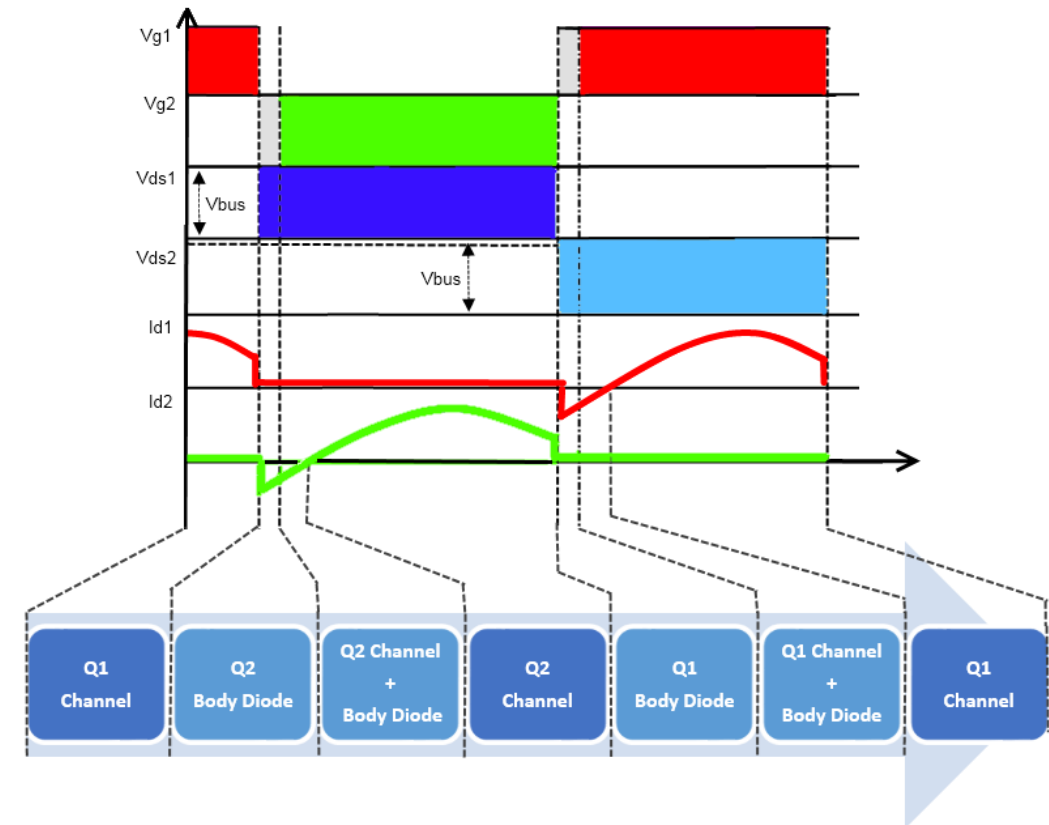

The majority ZVS applications do not require MOSFETs with fast recovery diodes.

MOSFET Role to Achieve the ZVS

MOSFET Body Diode for Very High Power and «Non-Standard» operations

Transitories Hard Switching Operation

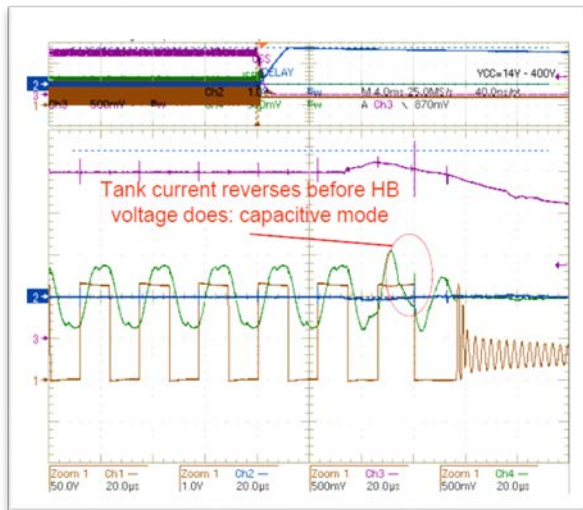

capacitive mode

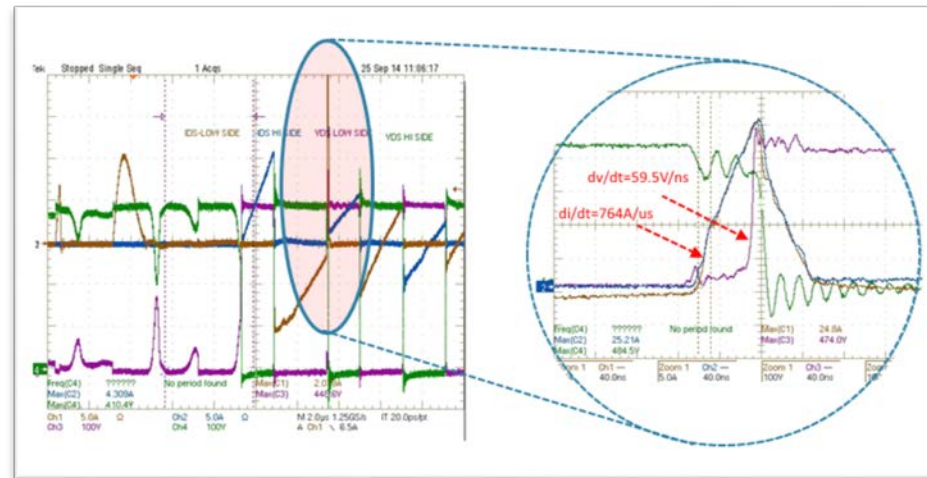

switching at start-up

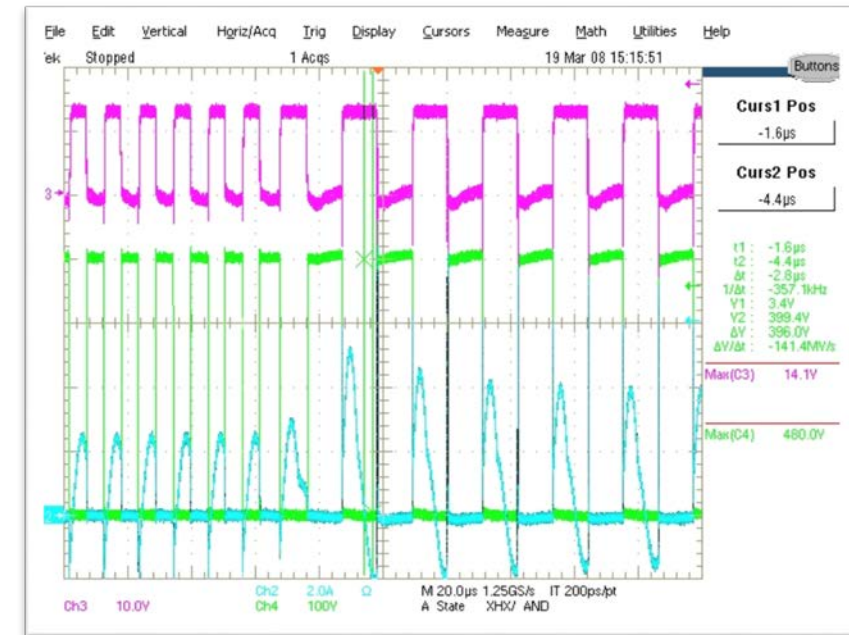

fast load transition

Applications with recognized risk require MOSFETs with fast recovery diodes.

- AN4720: Half bridge resonant LLC converters and primary side MOSFET selection
- EDN magazine: Why use a Fast Diode MOSFET in a LLC topology

MOSFET's Key Features and Benefits in PSU

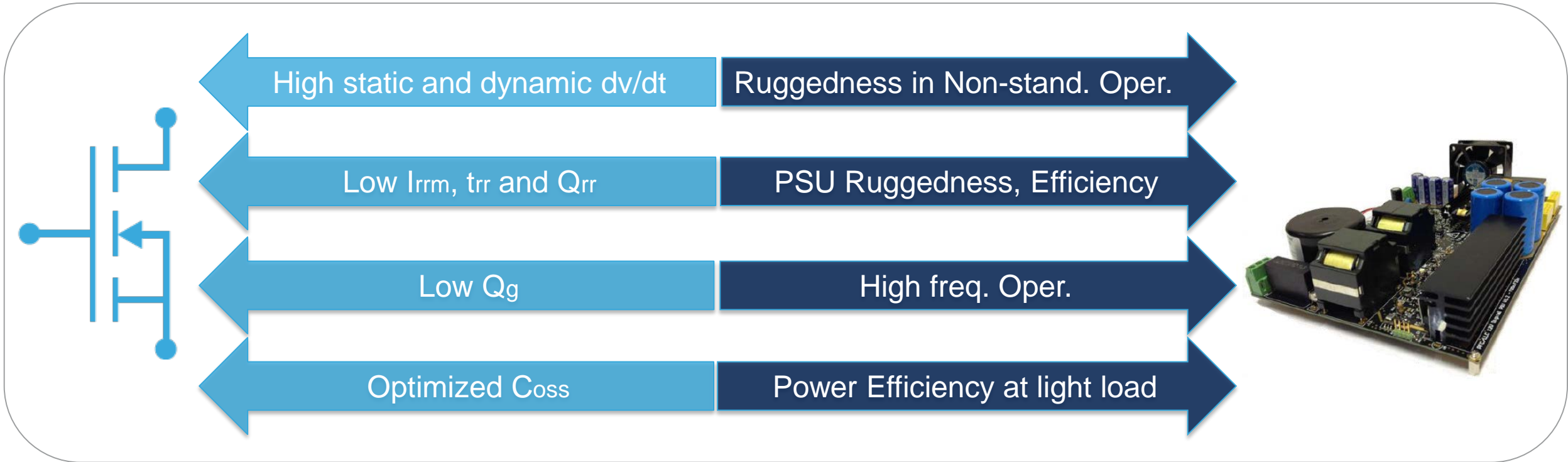

Sub Topics Overview

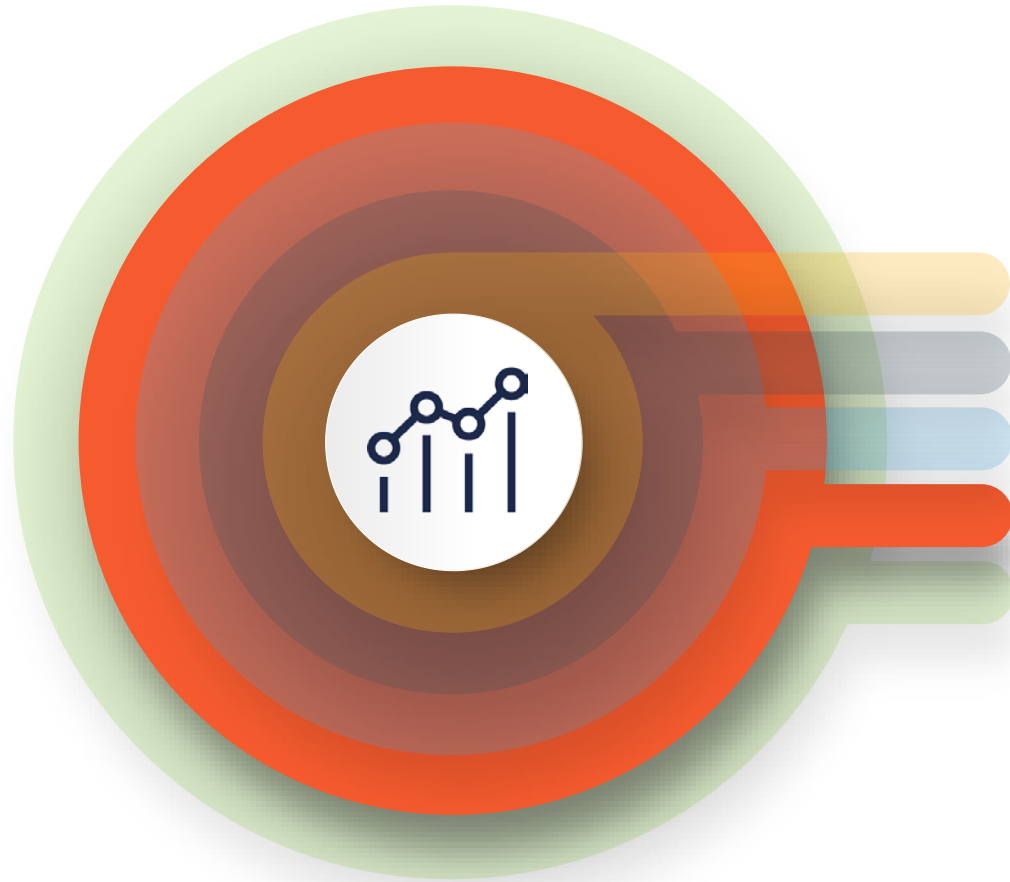

MDmesh™ M6

Benchmark in LLC system



Evaluation Coss losses in switching

Reference Boards for resonant converters

Benchmark M6 vs Competitor's products
90mΩ and 180mΩ

MOSFET contribution in Power Efficiency

Evaluation Coss Losses in Switching

In resonant half-bridge topology each MOSFET is charged and discharged through the energy transferred between the inductor and each Coss, to mimic this behavior we use the below test jig circuit.

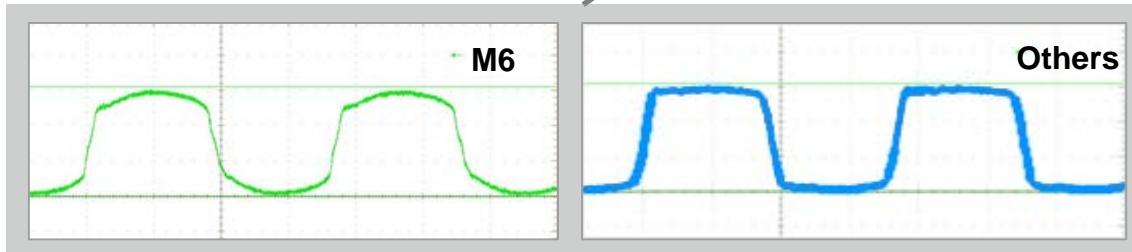
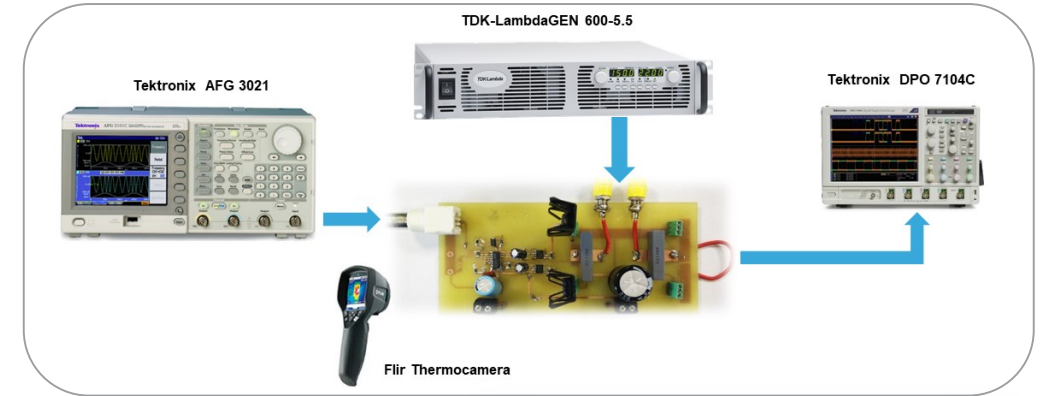
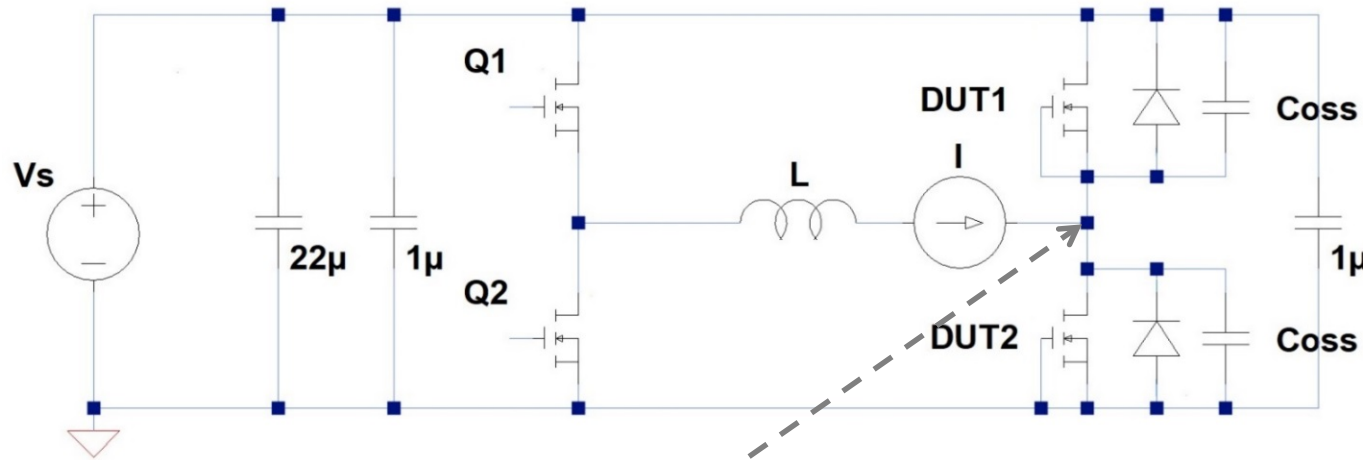

M6 has better VDS symmetry this makes a very efficient energy swap between Coss

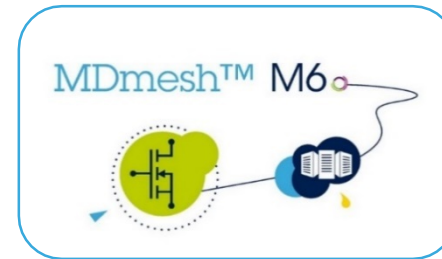

Coss Related Energy Loss in Power MOSFETs Used in Zero-Voltage-Switched Applications

J.B. Fedison, M. Fornage, M.J. Harrison, D.R. Zimmanck
Enphase Energy, Inc.
Petaluma, CA, USA

Abstract— This paper presents a novel method to measure the output capacitance (C_{oss}) related energy loss per switching cycle in power MOSFETs used in zero-voltage-switched (ZVS) applications. It is shown that a simple model using C_{oss} in series with a resistance R_{on} is inadequate for describing the observed energy loss and a different model is needed. This work also shows that the traditional hard-switch test method for measuring the dynamic performance of power MOSFETs are inadequate for describing the dynamic performance of power MOSFETs used in ZVS applications. Finally, this work proposes a new power MOSFET figure of merit suitable for differentiating the performance of MOSFETs for use in ZVS applications.

I. INTRODUCTION

The advancement of power MOSFET technology over the past two decades has enabled dramatic improvements in the performance of power converters resulting in systems with higher efficiency and lower cost. Indeed, MOSFETs utilizing charge compensated structures at both moderate and high voltage have largely replaced the conventional silicon MOSFET. New generations of devices have even broken the one specific on-resistance limit of silicon, for example 600V silicon superjunction MOSFETs have area specific on-resistance of five times lower than the theoretical limit for silicon [1-2].

One of the common figures of merit for power MOSFETs is the so called hard-switched figure of merit (FSOM) which is the product of the gate-to-drain charge (Q_{gd}) and the on-state resistance ($R_{DS(on)}$) where lower is better [3-4]. This figure of merit is useful for comparing different MOSFET technologies regardless of device area but is not relevant to hard-switched topologies where the Miller effect significantly increases Q_{gd} . However, this figure of merit is not useful in differential MOSFETs for zero-voltage-switched (ZVS) topologies where Q_{gd} is not exacerbated by the Miller effect.

There is a need for a new figure of merit specifically tailored to ZVS topologies because these topologies are becoming more widely adopted as they enable designers to create high-frequency power converters with higher efficiency and ultimately lower cost. Not only do designers need a valid way to compare the relative merits of available MOSFETs for ZVS designs but also MOSFET manufacturers need a way to assess new device generations for applications that use ZVS.

As power engineers strive to create systems with ever higher efficiency, often for purposes of compliance with



Coss Related Energy Loss in Power MOSFETs Used in Zero-Voltage-Switched Applications

J.B. Fedison, M. Fornage, M.J. Harrison, D.R. Zimmanck - Enphase Energy, Inc. - Petaluma, CA, USA - APEC 2014



LLC Open-Loop Reference Converter

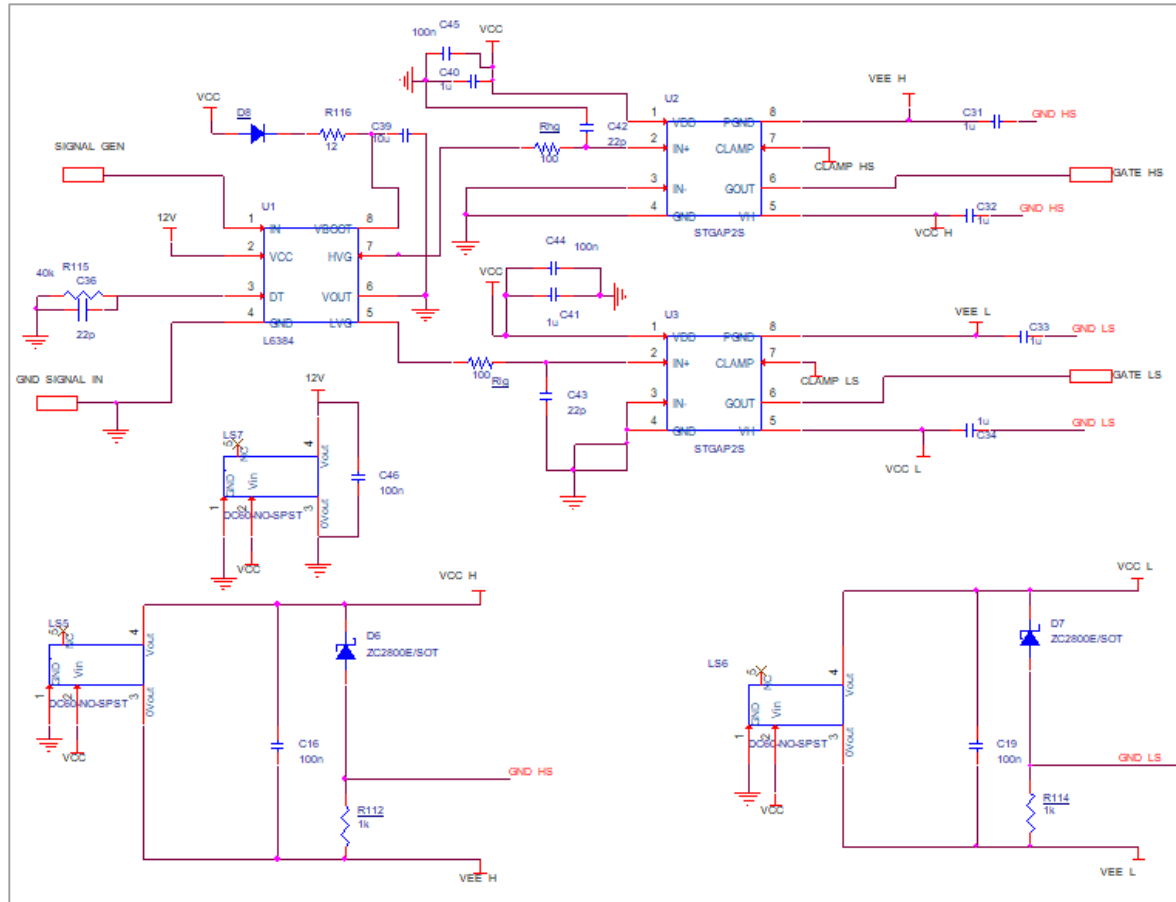

Driving section

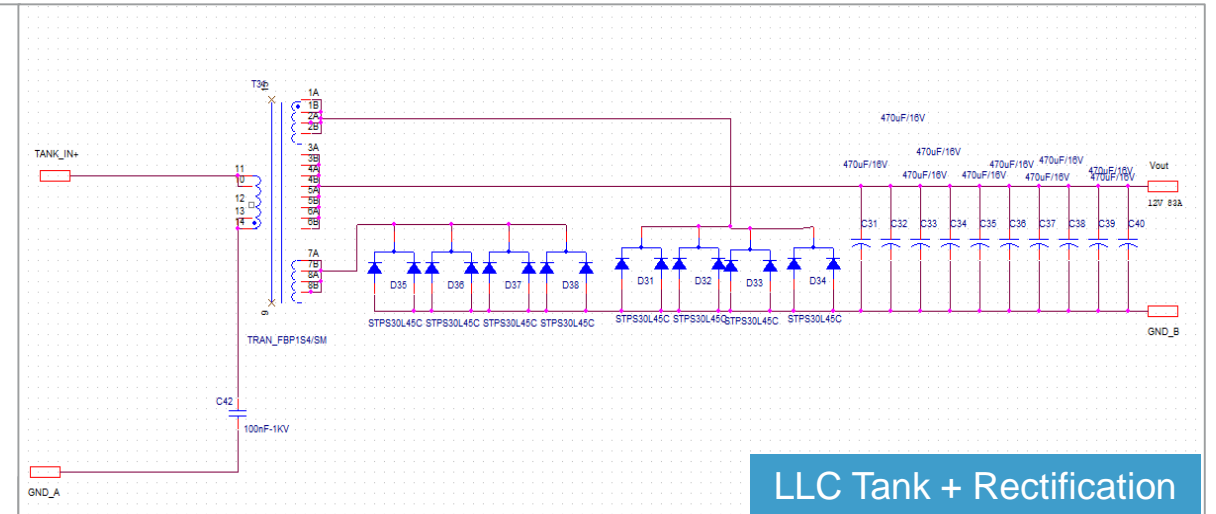

LLC Tank + Rectification

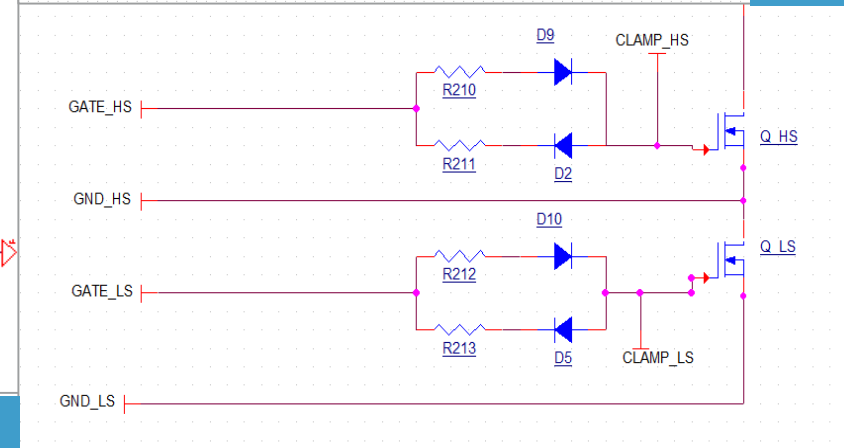

Bridge section

EVALJIG-HBLLC-v4.1

TO-220

TO-220FP

TO-247

L6384ED

High voltage half-bridge driver

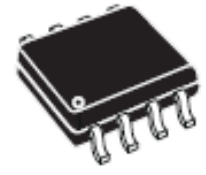

STPS30L45CT

Low drop power Schottky rectifier

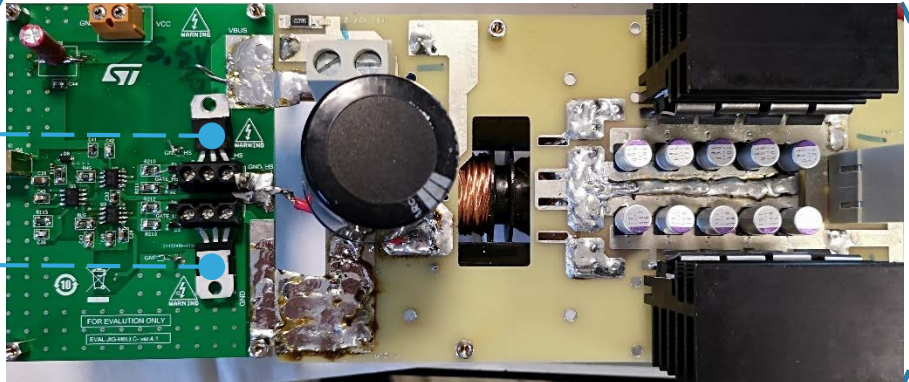
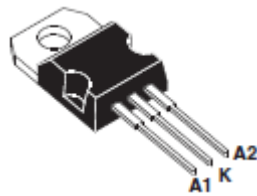

STGAP2S

High voltage half-bridge driver

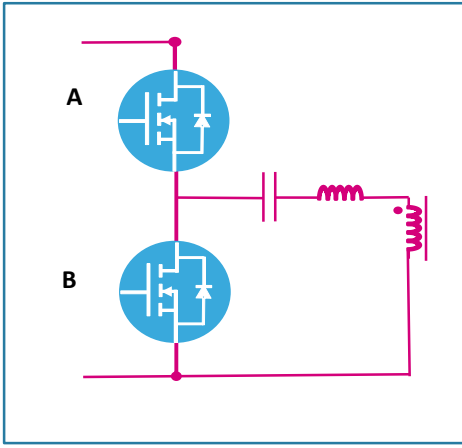
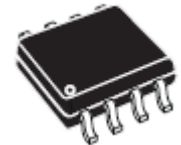

Vin (V)	Vout (V)	Ron (Ω)	Roff (Ω)	DT (ns)
400	12	39	11	400

Reference Boards for Resonant Converters

Using reference boards it is possible:

- analyze the electrical and thermal aspects of the devices in LLC versus load.
- compare the ST's latest high-voltage MOSFETs to our previous technology as well as competitor's devices.

To predict the behavior of the devices inside the customer's applications dedicated test boards are used to analyze device's implication at light load (as well as at no load) and along the load range.

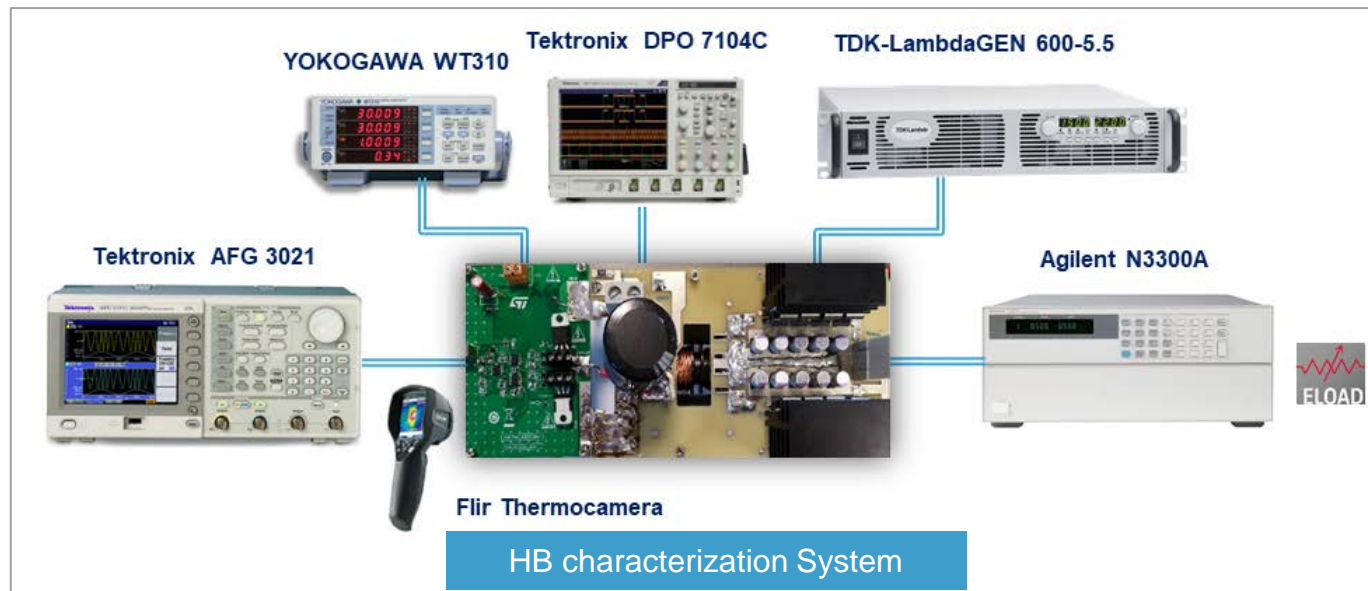
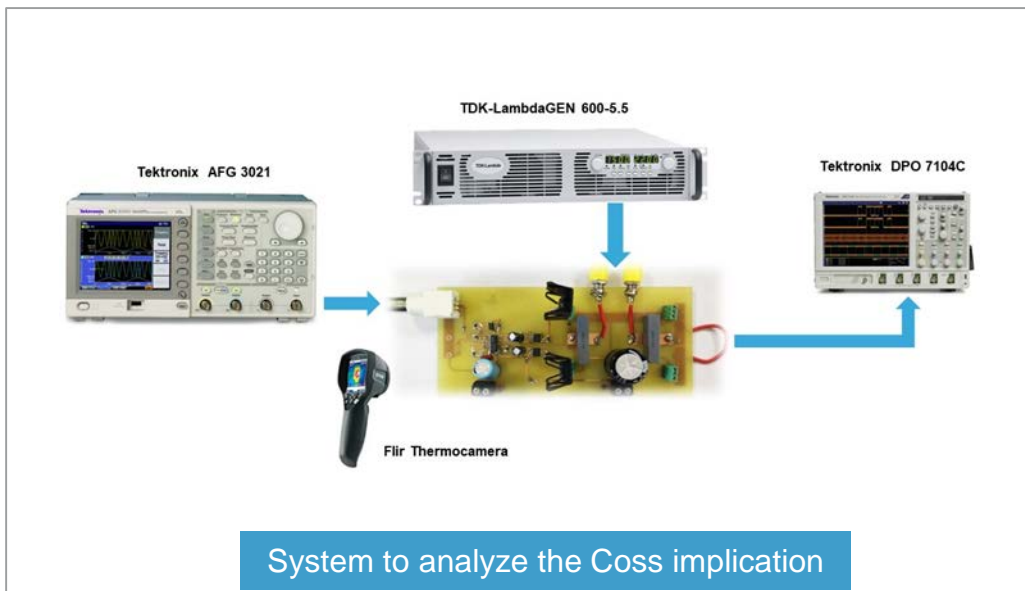

Evaluation losses in C_{oss} - $R_{DS(on)} = 90m\Omega$

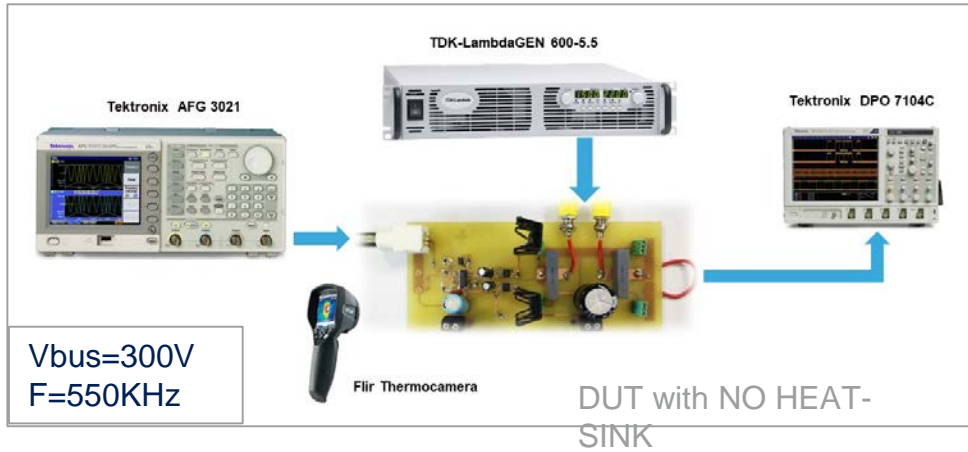

	STP36N60M6	Competitor 1	Competitor 2	Competitor 3	Competitor 4
	TO-220	TO-220	TO-220	TO-220	TO-220
BV_{dss} (V)	600	600	600	600	600
$R_{DS(on)_{max}}$ (m Ω)	99	99	99	88	104
$VG_{St_{typ}}$ (V)	4	3.5	3	3.2	3

To be able to discriminate the case's temperature of each device we consider a minimum delta of 2°C according with the used thermal camera resolution.



Average of the T_{case} values measured on two couples of the same p/n

Application Performances - $R_{DS(on)}=90m\Omega$

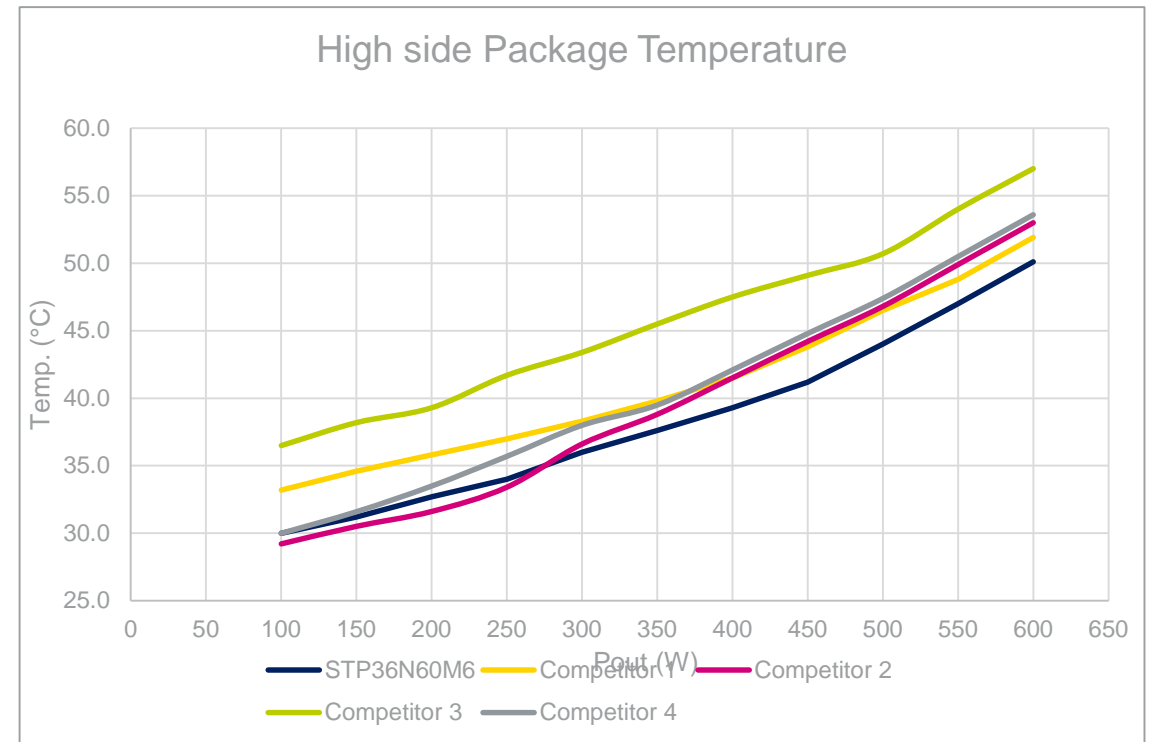

STP36N60M6 the best for power efficiency and device's temperature

Device in TO-220 tested without heat-sink



	STP36N60M6	Competitor 1	Competitor 2	Competitor 3	Competitor 4
	TO-220	TO-220	TO-220	TO-220	TO-220
BVdss (V)	600	600	600	600	600
$R_{DS(on)max}$ (mΩ)	99	99	99	88	104
VGSt_{typ} (V)	4	3.5	3	3.2	3

* Datasheet values

Switch Off energy @ Max Pout

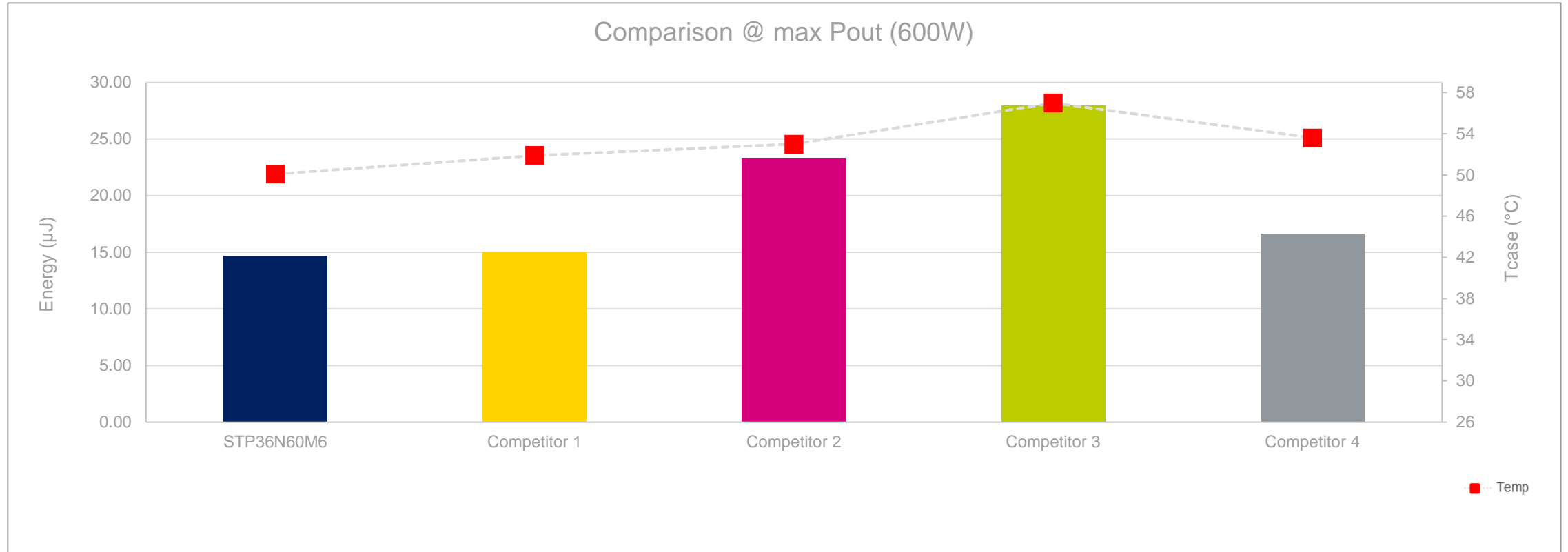

MOSFET Contribution in Power Efficiency

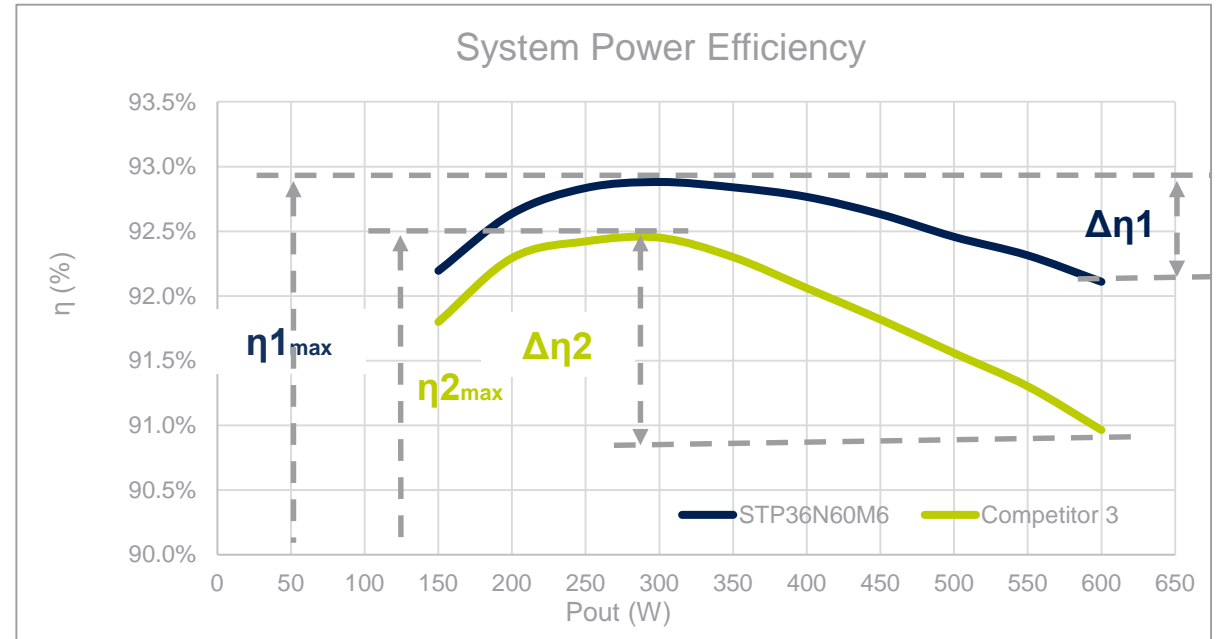
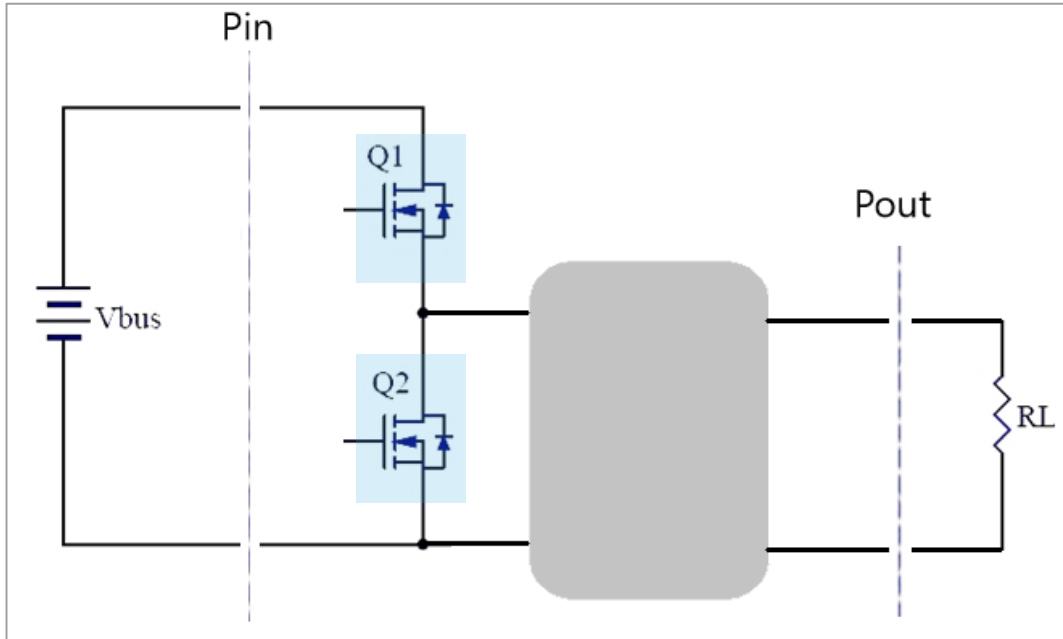

MOSFETs have a key role to to

- maximize the power efficiency (η_{max})
- minimize the efficiency drop from the max caused by an increase of power demand ($\Delta\eta$)
- maximize the average level of the power efficiency inside the P_{out} range

System Efficiency and Temperature @max Pout

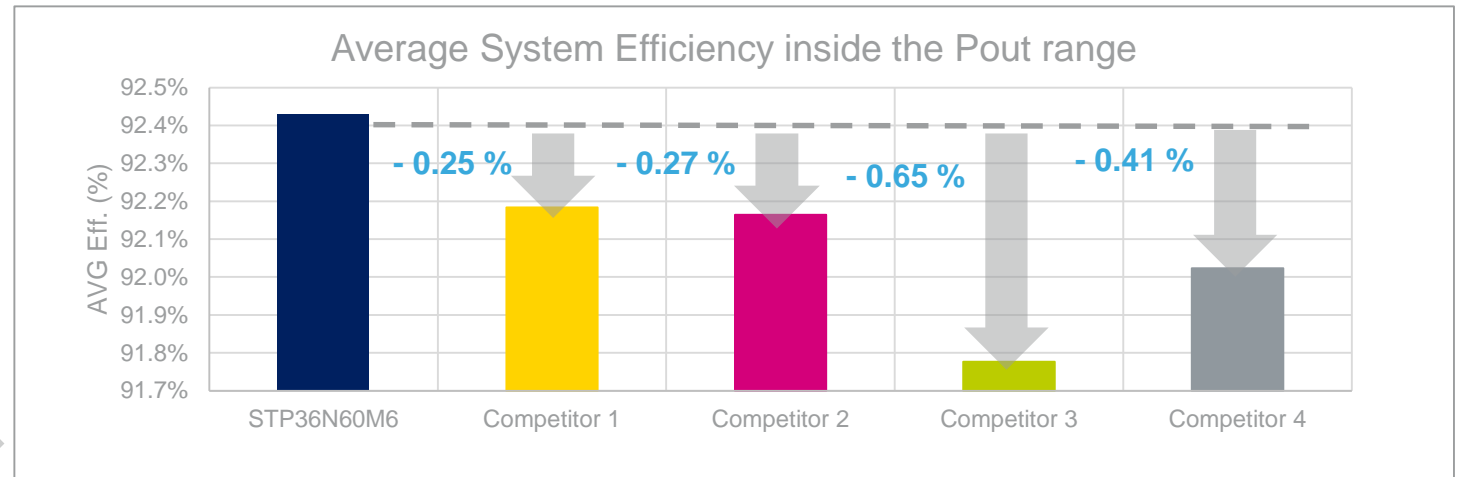
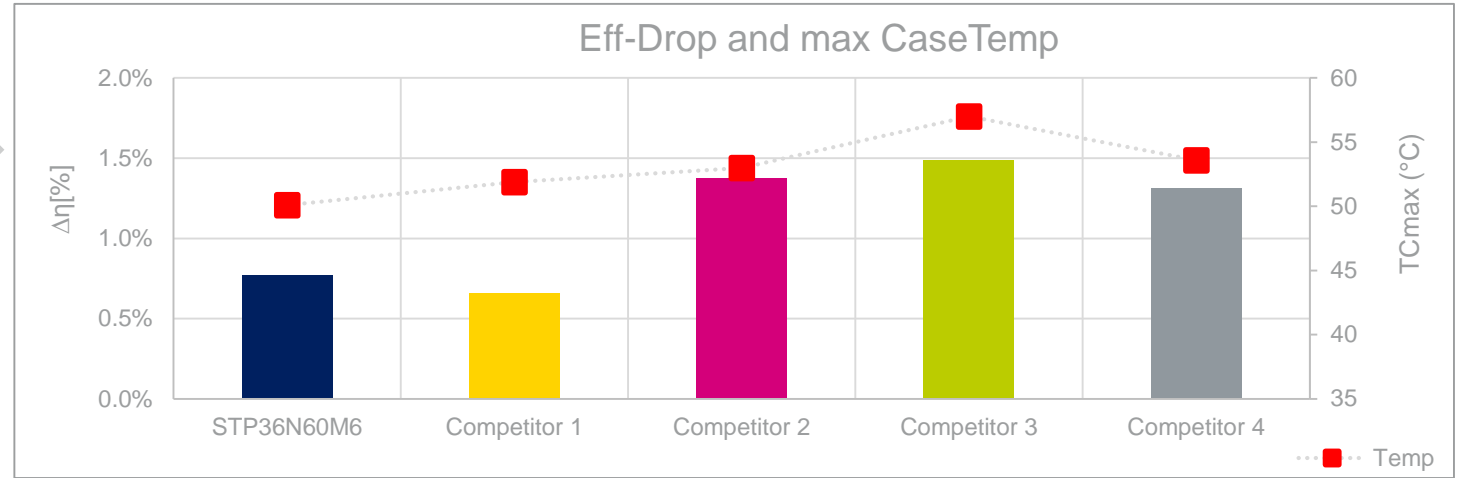
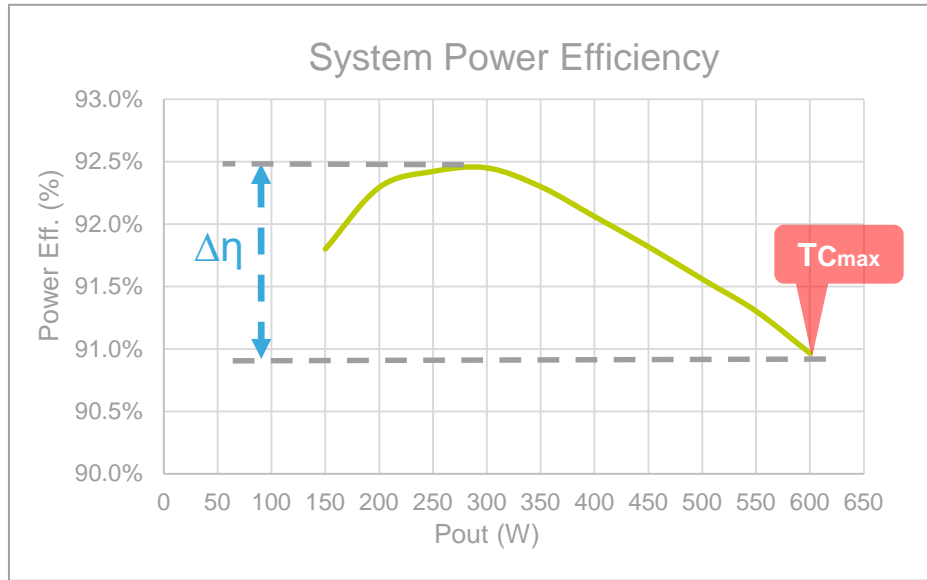

Evaluation Losses in C_{oss} - $R_{DS(on)} = 180m\Omega$

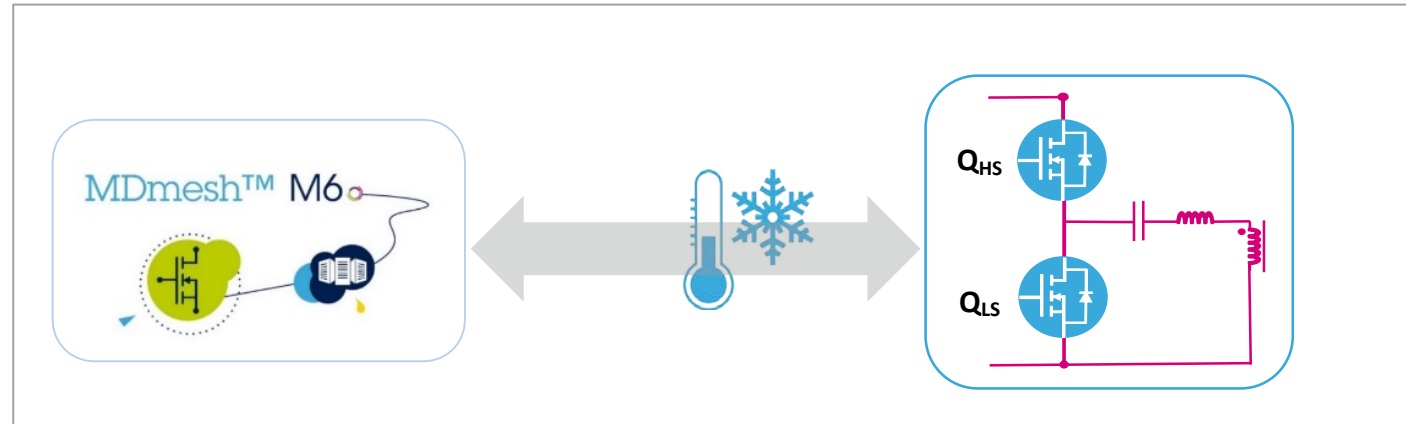
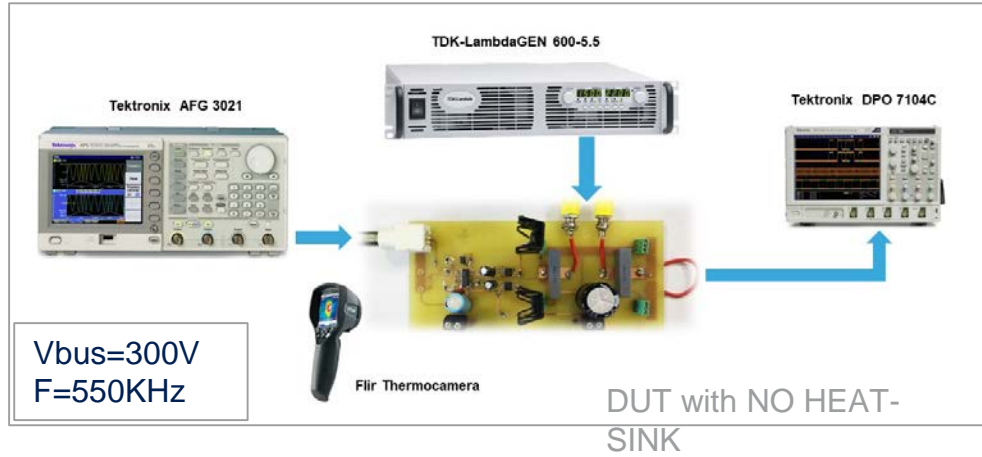

MDmesh™ M6 MOSFET series perfect for resonant topologies. The optimized C_{oss} improves the Power Efficiency at light load

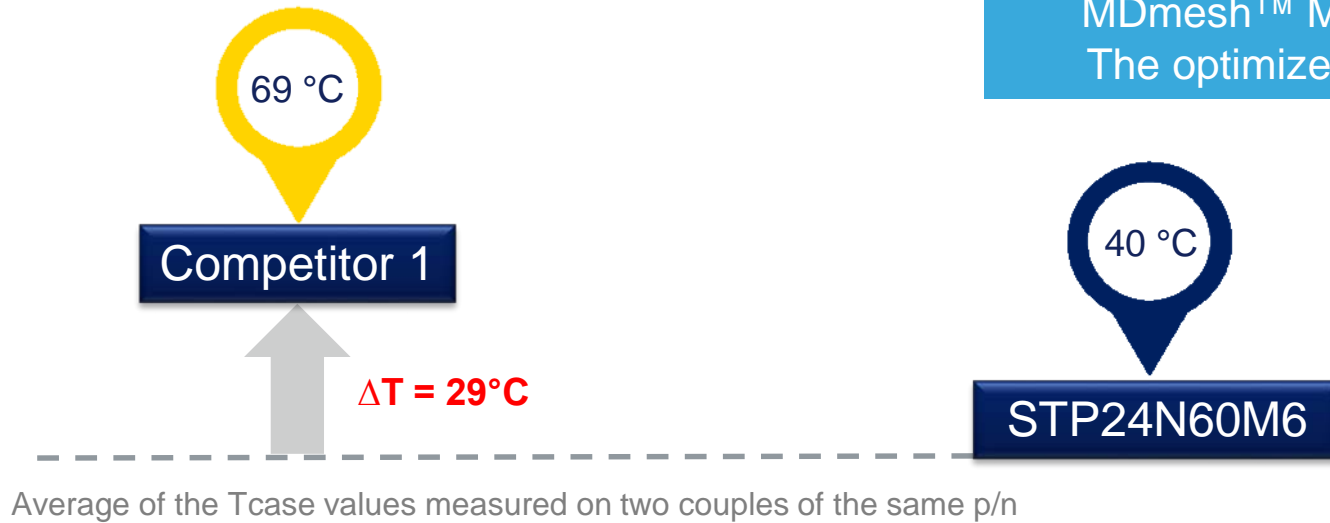

Parameter	STP24N60M6	Competitor 1
* BV_{dss} min (V)	600	600
* $R_{DS(on)}$ max (m Ω)	190	180
* $V_{GS(th)}$ typ (V)	4	3.5

Application Performances of M6:180mΩ

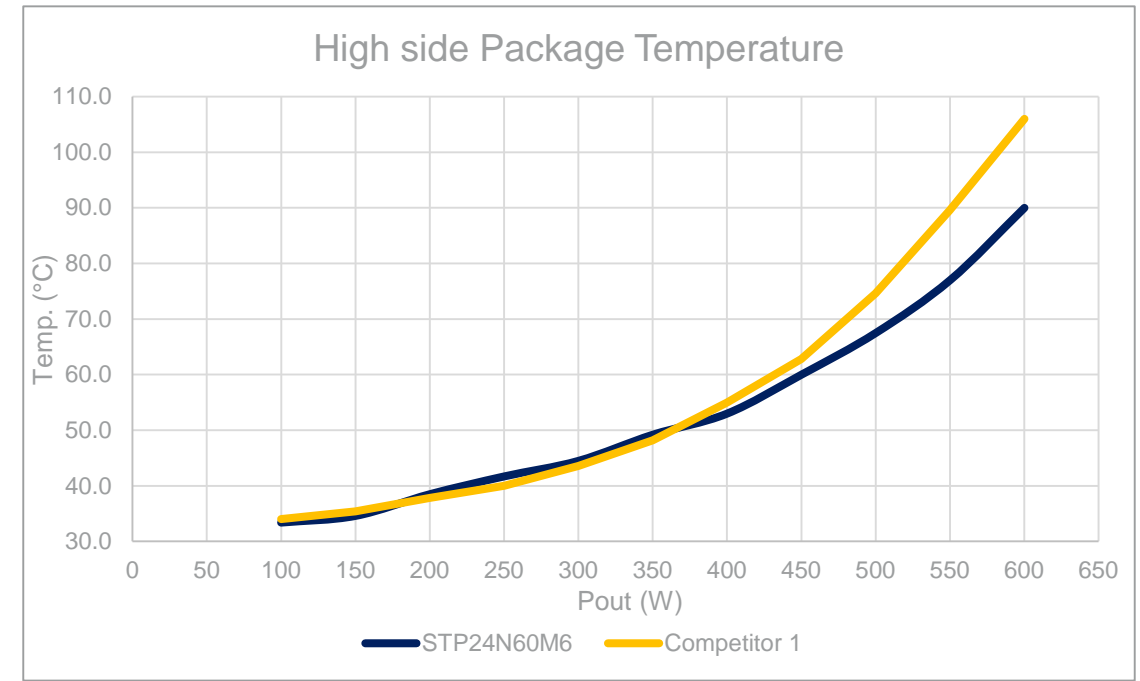
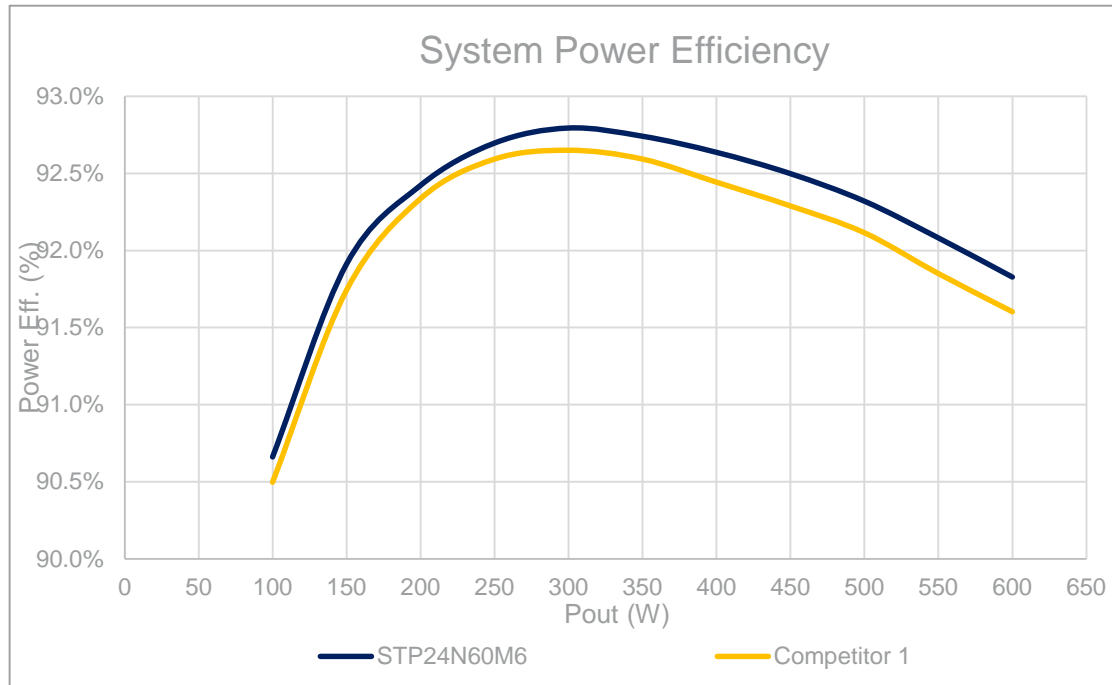

STP24N60M6 the best for power efficiency and device's temperature along the load range

Device in TO-220 tested without heat-sink



	STP24N60M6	Competitor 1
Parameter		
* BVdss min (V)	600	600
* RDS(on)max (mΩ)	190	180
*VGS(th) typ (V)	4	3.5

* Datasheet values

Switch Off Energy @Max Pout and Average Efficiency

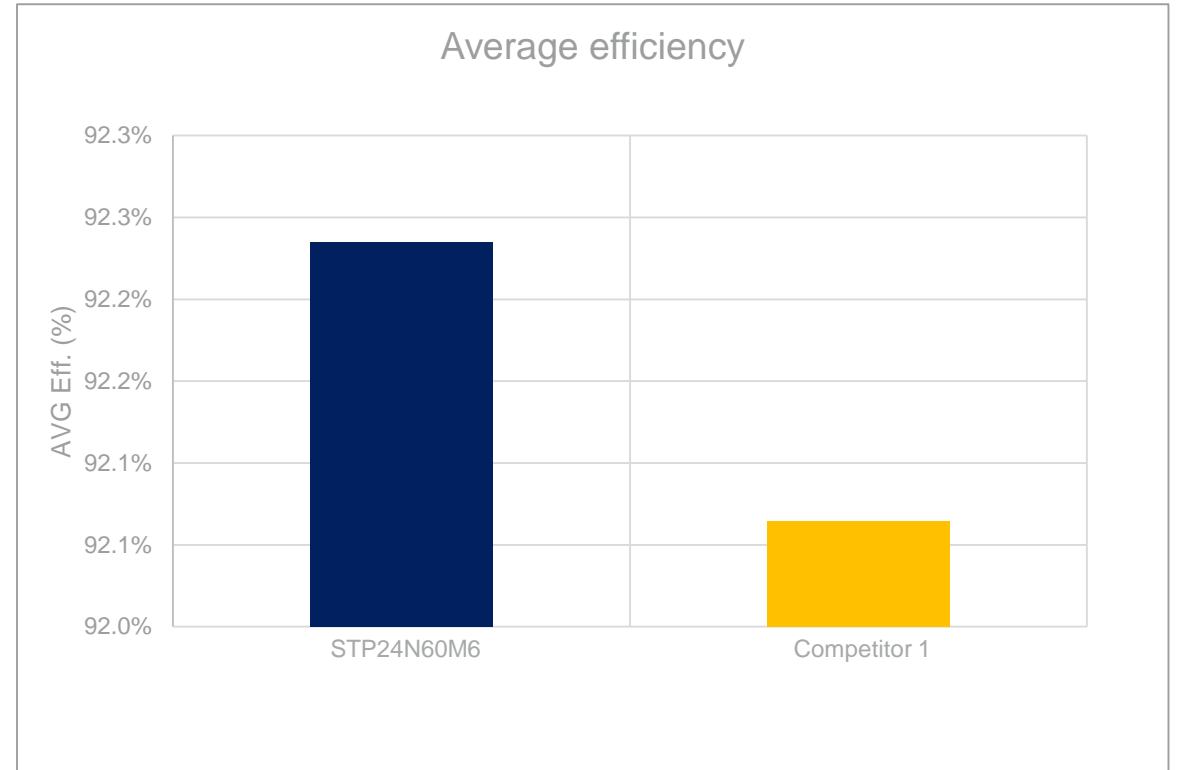
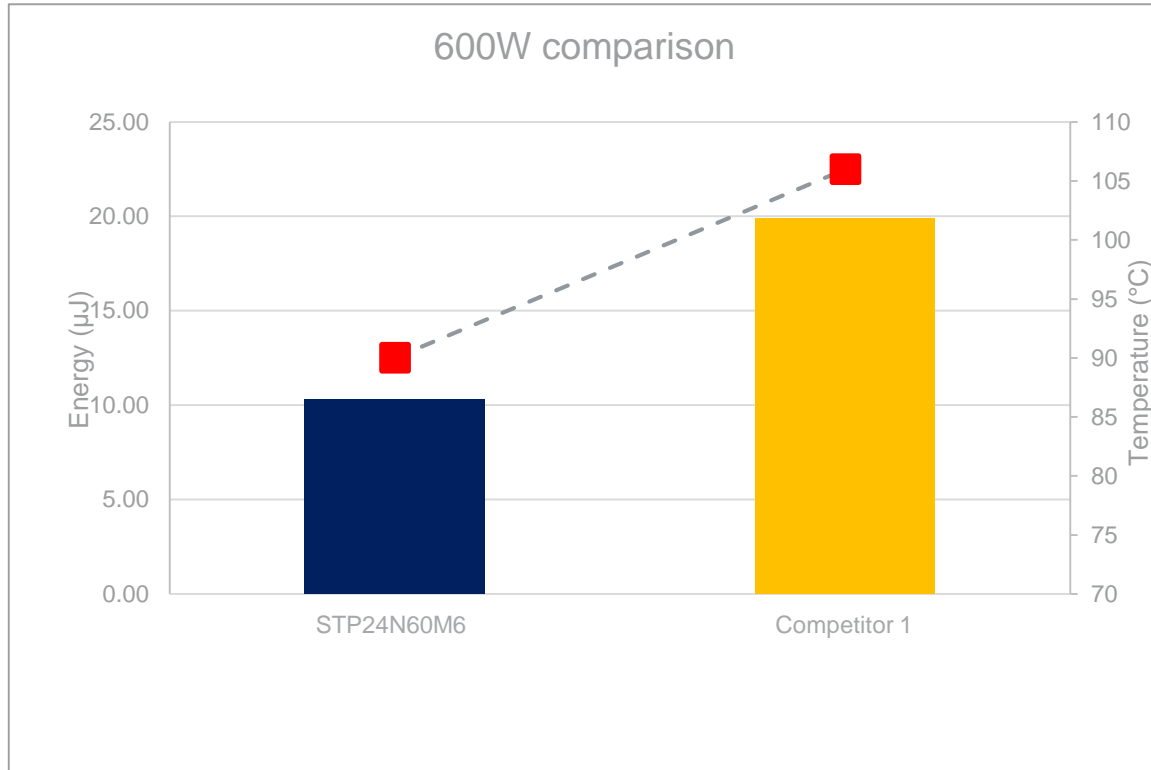

650V & 1200V SiC MOSFETs

The Real Boost for Efficient Designs

Lower Losses, High Efficiency, Reduced Footprint: Breakthrough in High Voltage Converters



SiC MOSFET series

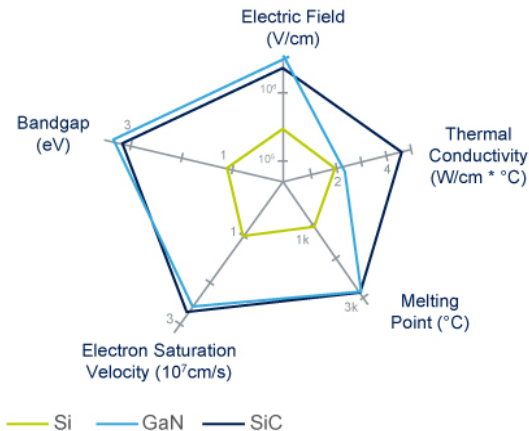
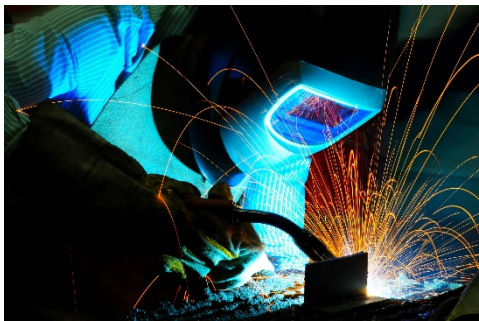

- Leading to new technology platform with awesome Figure Of Merit
- Very Low on-state resistance
- 200 °C Max junction temperature
- Very fast and Robust intrinsic body diode
- Industrial and Automotive Grade qualified
- Outstanding system efficiency and reduced cooling requirements

Applications

- Traction inverters
- On board chargers
- DC-DC converters
- SMPS
- Auxiliary power supplies
- UPS
- Solar
- Welding

Gallium Nitride (GaN): a New Member of ST's Wide Band-Gap Family

Enables increased power density, higher frequency operation and improved efficiency

First product under development:
SGT120R65ALD*

Product Features

- $R_{DS(on)} = 120 \text{ m}\Omega @ 10 \text{ A}$
- $BV_{dss} > 650 \text{ V}$

PowerFLAT™ 8x8

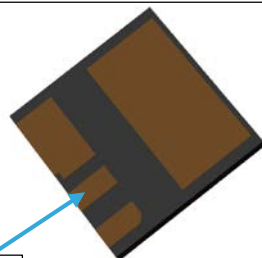

Kelvin pin for optimized Gate Driving

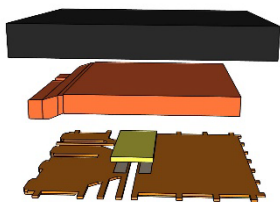

Package section

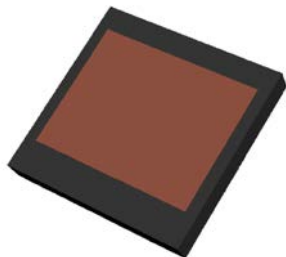

Top Side Cooling

*Under Development

Key Benefits

- Main breakthrough for high Voltage Power conversion
- Compact Design
- Smaller form factor and increased Power density

Conventional adaptor based on Silicon switch*



Adaptor based on GaN switch

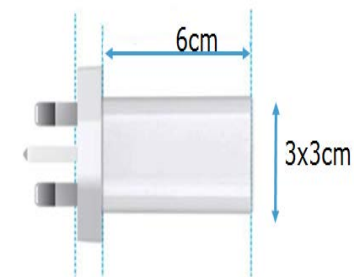

*Super Junction power MOSFET

STPAK™: Multi Sintering Package

Ideal for Electric Vehicle applications

High Power Density for Traction Inverter

Main Features & Benefits

- Multi sintering solution for better performance and higher reliability
- AEC-Q101 qualified, T_j (max) = 175 °C
- 650V / 1200 V Voltage rated
- Suitable for silicon IGBT and SiC Power MOSFET technologies
- Compact and modular design approach
- High power density
- Improved thermal performance due to direct sintering to the bottom of the heatsink
- Sense pin for enhanced control

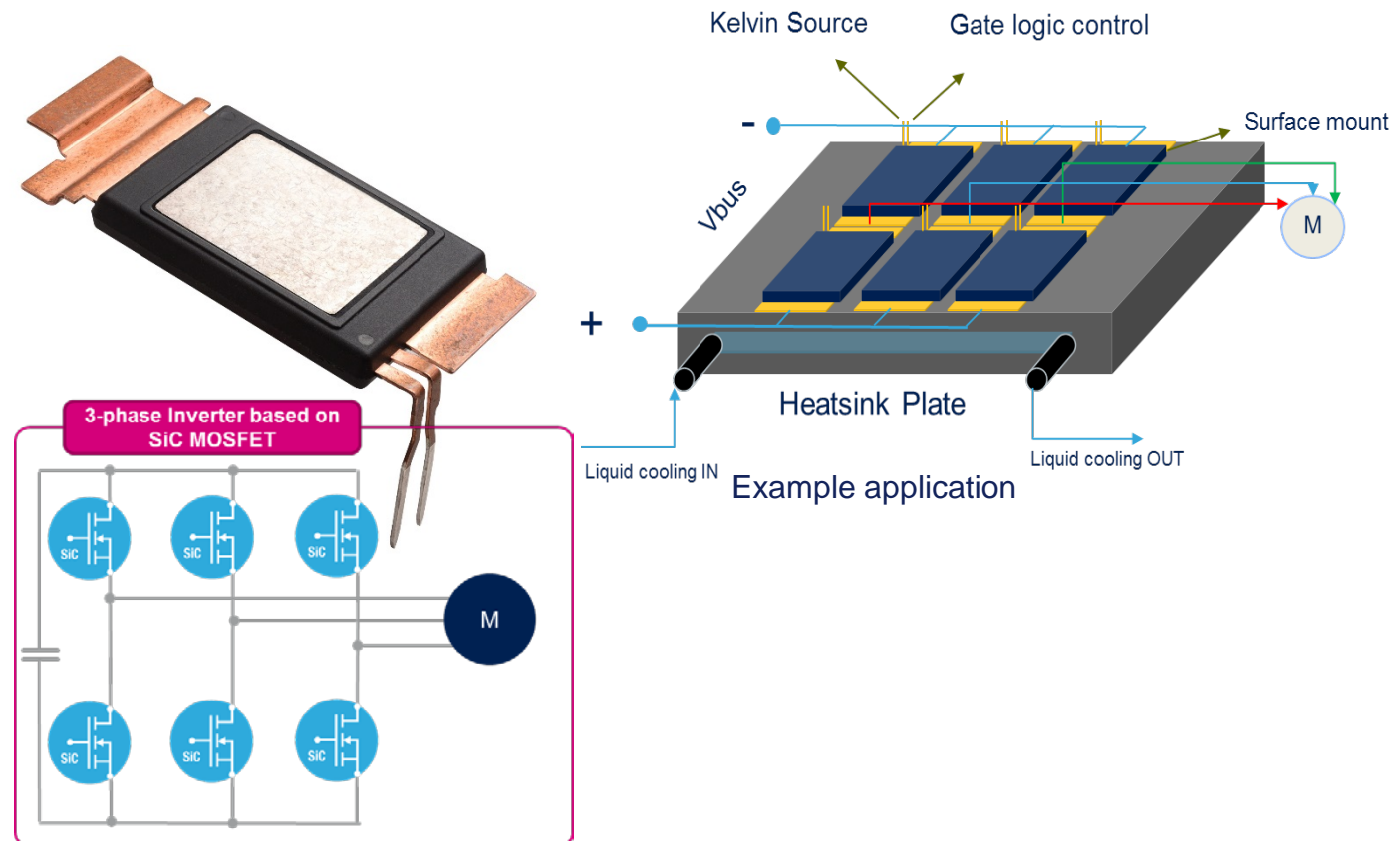

650V-1200V G2 SiC Rectifiers for EV

SiC 650 V G2 and 1200 V technology: using JBS (Junction-Barrier Schottky)



Soft switching behavior

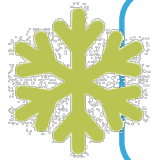

Low fwd conduction losses
Low switching losses



High forward surge capability



High power integration

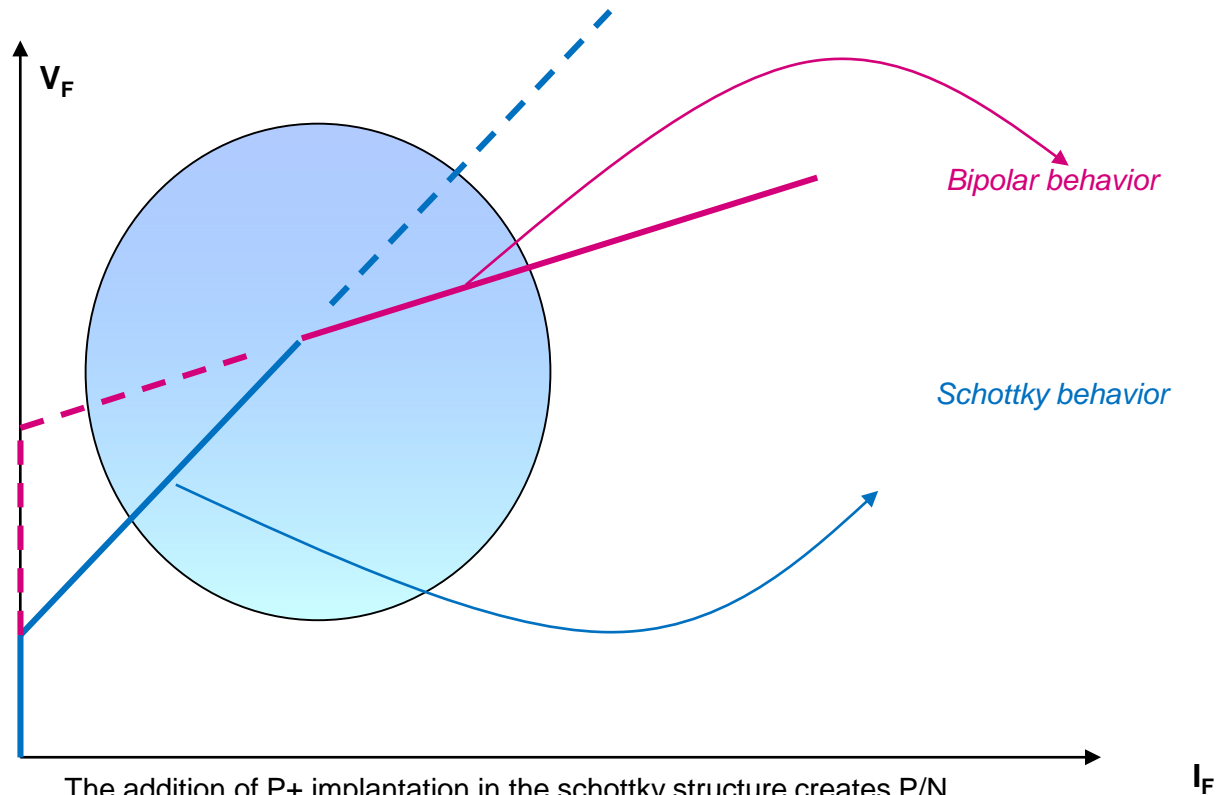

The addition of P+ implantation in the schottky structure creates P/N junctions. The surge forward current capability can be increased while keeping $T_J < T_{J(MAX)}$

650V-1200V G2 SiC

Superior Performances vs Competition

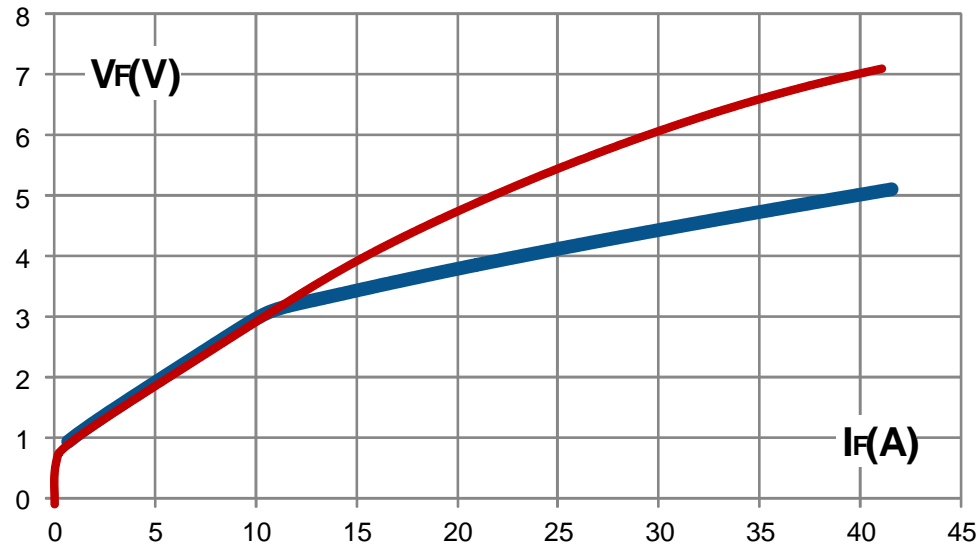

SUPERIOR FORWARD SURGE CAPABILITY

More efficient clamping effect vs. best Competitor

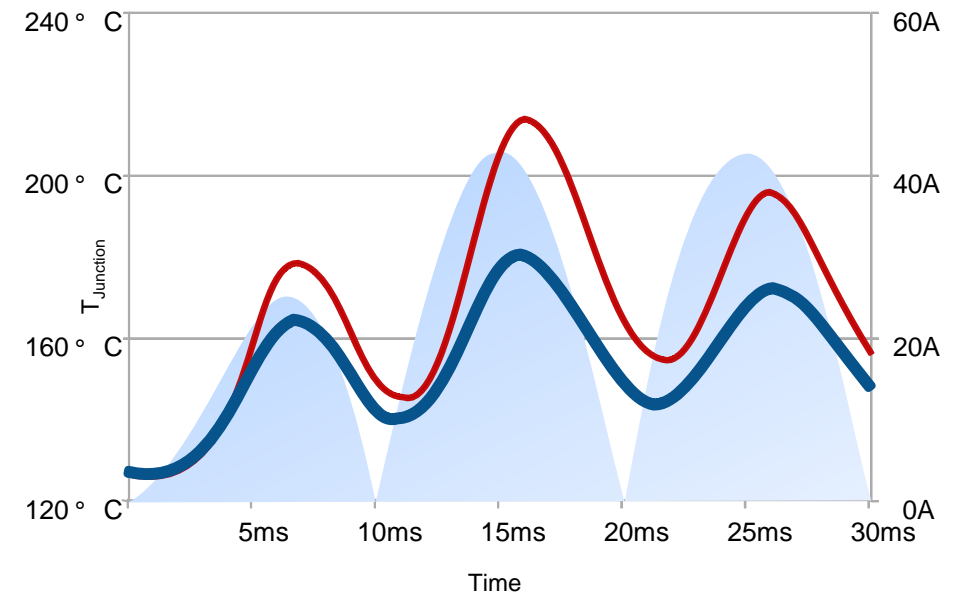

SMALLER TEMPERATURE SWING

Better clamping effect and lower V_F reduces the T_{Junction} during transient phases in the application.

650V SiC Diode Portfolio

Extend Package Portfolio with Flat Package

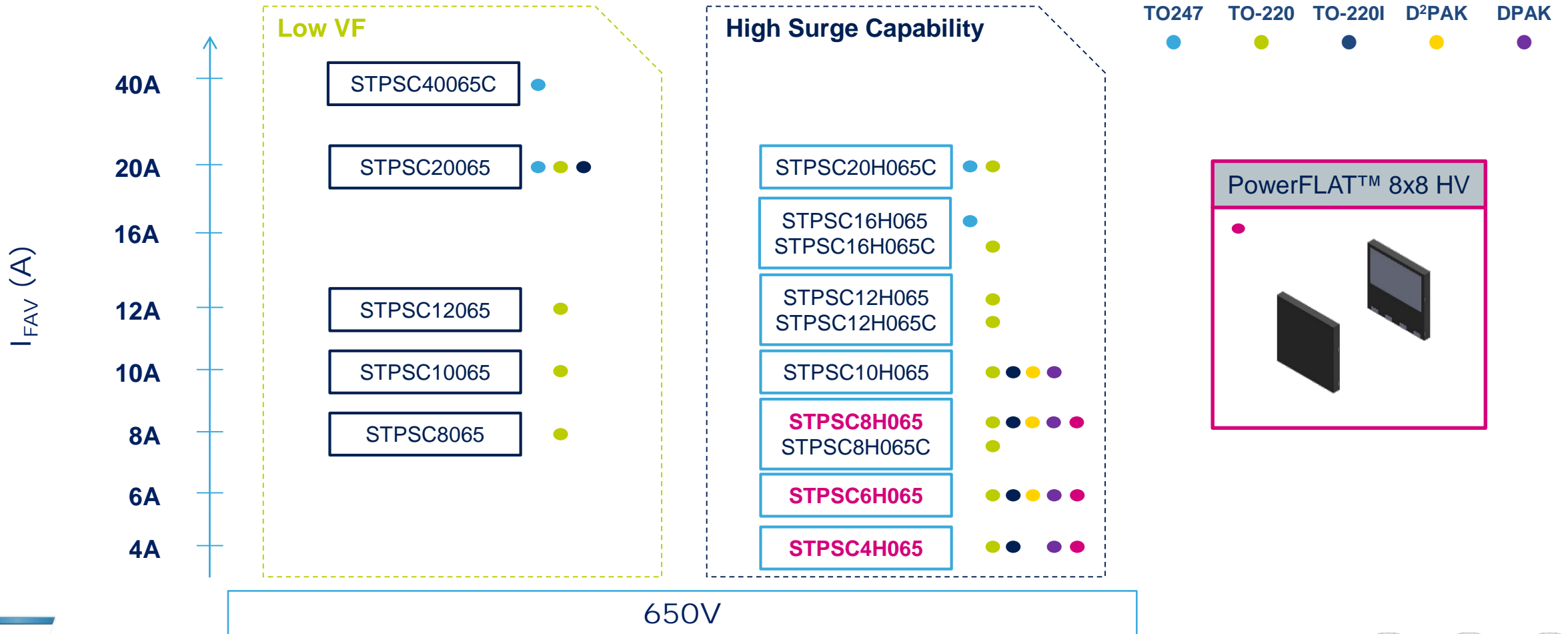

STripFET™ F7

40-100V Power MOSFET Technology

Key Characteristics

- Among the best RDS(on) in the market
- Minimal RDS(on) x Qg (FoM)
- Low input capacitances
- Optimized Crss/Ciss capacitance ratio
- High avalanche ruggedness
- Low intrinsic diode recovery charge

Features

- Extremely Low Rds(on)
- Optimized body diode (low Qrr)
- Intrinsic capacitances (Optimal capacitance Crss/Ciss ratio)
- ST provides several package solutions, including PowerFLAT 5x6 and H²PAK

Application

- Power Tools
- Fork Lifts
- Electric Light Transportation
- TELECOM and SERVER
- SMPS
- Adapter/Battery Charger
- UPS
- Solar Inverter
- Lighting/Display

Benefits

- Low conduction losses
- Excellent switching performance (higher efficiency)
- No EMI issue
- A more complete solution provided to the customer

STripFET™ F8

30-150V Power MOSFET for High End > 500KHz

Applications

- Power Tools
- Fork Lifts
- Electric Light Transportation
- Telecom and Servers

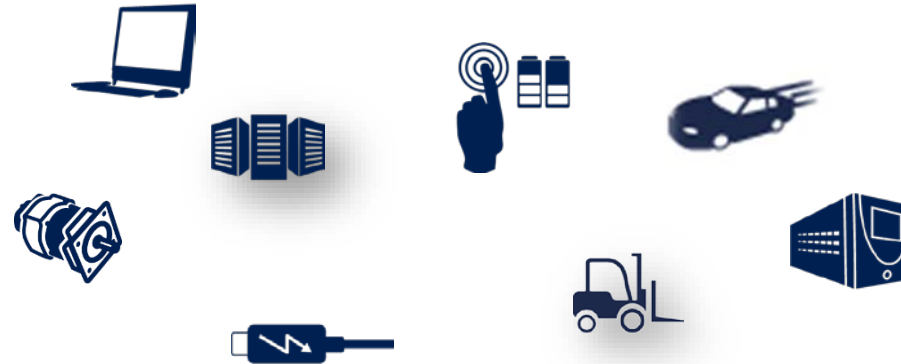

- SMPS
- Adapter/Battery Charger
- UPS
- Solar Inverter
- Lighting/Display

Features

- Lower $R_{DS(on)}$ x Area (-40% Vs. F7)
- Extremely Low Q_g/Q_{gd}
- Q_{rr} & Soft switching F7 like
- Extremely low thermal resistance

Benefits

- Reduced conduction power losses
- Reduced switching losses and passive sizes
- Reduced noise immunity
- Improved current capability and power dissipation
- Low EMI & turn on losses
- Extended package offer to enhance silicon performances

ST App Finder



MOSFET



IGBT



Brand new finders, to allow an easier and faster recollect of the most important information about any power transistor in ST's portfolio.

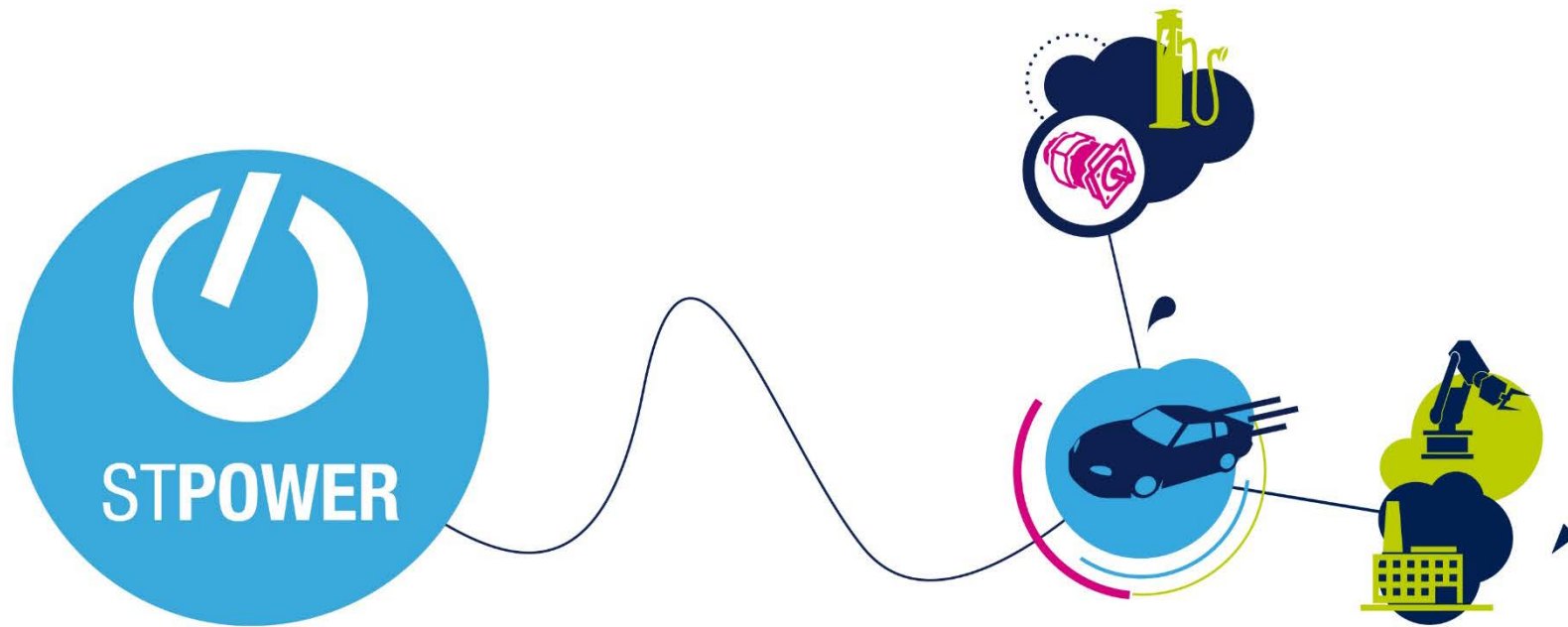

www.st.com/stpower

650V & 1200V SiC MOSFETs

The real boost for efficient designs



SiC MOSFET series

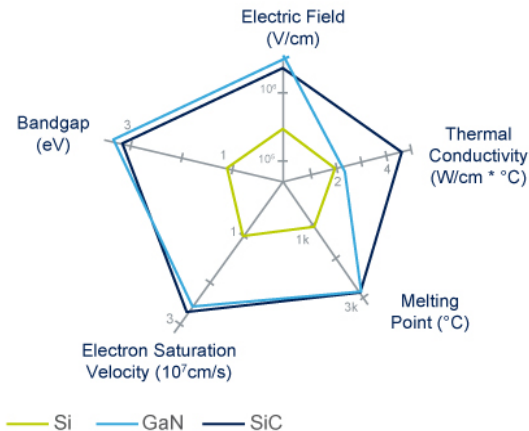
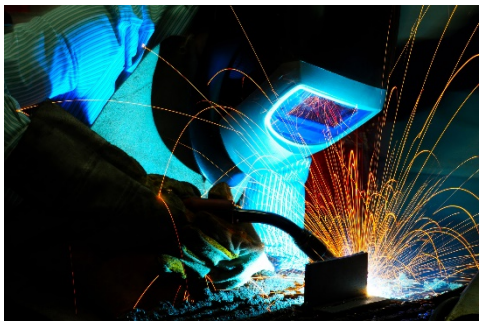

- Leading to new technology platform with awesome Figure Of Merit
- Very Low on-state resistance
- 200 °C Max junction temperature
- Very fast and Robust intrinsic body diode
- Industrial and Automotive Grade qualified
- Outstanding system efficiency and reduced cooling requirements

Applications

- Traction inverters
- On board chargers
- DC-DC converters
- SMPS
- Auxiliary power supplies
- UPS
- Solar
- Welding

The Enphase Microinverter System with



Extend Package Portfolio with Flat Package

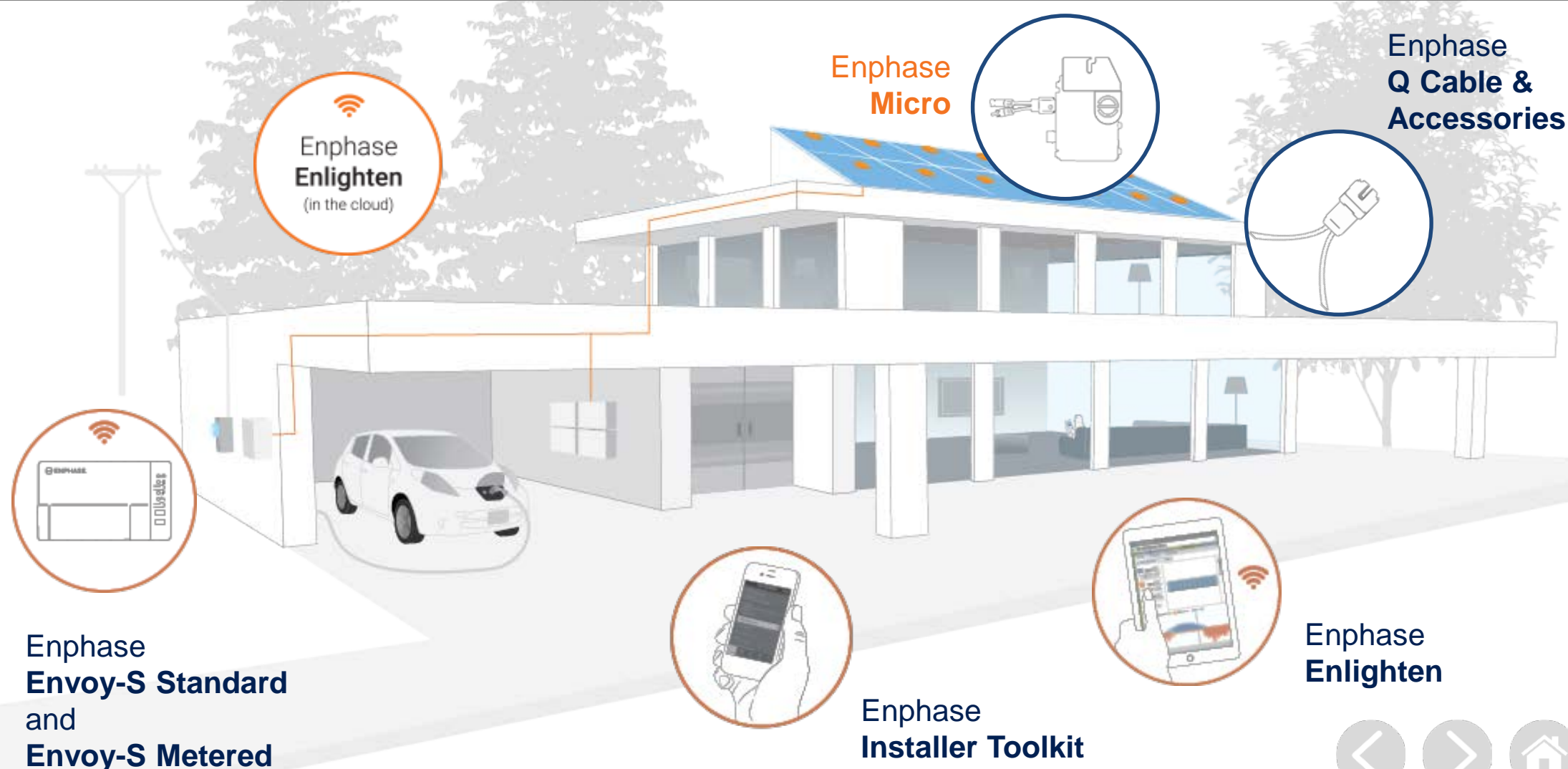

Enphase
Enlighten
(in the cloud)

Enphase
Micro

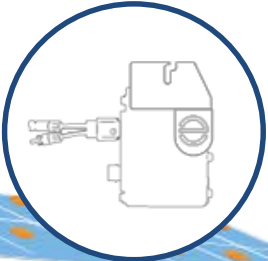

Enphase
Q Cable & Accessories



Enphase
Envoy-S Standard
and
Envoy-S Metered



Enphase
Installer Toolkit



Enphase
Enlighten



Enphase IQ Micro System

- **New Micros named IQ**
 - To highlight that the microinverters are the latest generation of smart Inverters
- **What do installers say IQ stands for?**
 - **I**nstalls
 - **Q**uickly



Enphase IQ Micros – Smarter. Lighter. Stronger. Better.

- **Lighter**
 - Much easier handling on the roof
 - IQ7 is 37% lighter than M250
 - IQ7 is 19% lighter than IQ6
- **Smarter**
 - Smart grid ready
 - Complies with advanced grid support, voltage and frequency ride-through requirements
 - Configurable for varying grid profiles
- **Stronger**
 - Supports both 60 and 72 cell modules
 - IQ7 delivers 4% more power than IQ 6
 - IQ7 delivers 28% more power than M-Series
 - Most efficient microinverter (96.5% EU)
- **Better**
 - Even more flexible and faster installation due to Q Cable
 - Safe, with a IP67 polymer enclosure



Enphase IQ Microinverters



- **IQ 7 Micro: 240 VA**

- Supports 60-cell modules
- Up to 350 Watt Modules
- 48 volt DC Maximum
- 16 units per 20 amp (230 VAC)*
- 96.5% EU Efficiency (230 VAC)



- **IQ 7+ Micro: 290 VA**

- Supports 60 & 72-cell modules
- Up to 440 Watt Modules
- 60 volt DC Maximum
- 13 units per 20 amp (230 VAC)*
- 96.5% Efficiency (230 VAC)

*Supports inline change from IQ 6 to IQ 7 with up-sized modules.

Part Count – Competitive Comparison

	String	String + Optimizer	Microinverter
Part count	1350-1650	1545-1940	250-420
Moving parts	3-10	3-10	0
Active components	100-150	115-190	35-50
Passive components	1000-1200	1150-1400	315-335
E-Caps	10	10	1-5
Mechanical	250-300	280-350	15-20

Enphase IQ Microinverter System in Summary

- **Faster to install**
 - Plug and play cabling on the roof
 - Easier to build a multi-array system
 - Lightweight
 - 38% lighter inverter, 50% lighter cabling*
 - Less material to transport and easier to carry
 - **Safe**
 - Double insulated IP67 enclosure
- **Wide range of modules supported**
- **Smart grid ready**



Faster and simpler
to install

Enphase from start-up to industry leader



Founded by
Raghu Belur and
Martin Fornage
in California

Enphase listed on
NASDAQ under
symbol ENPH



Home Energy Solution
AC Battery storage system
announced



More than 16 million
microinverters shipped,
representing over 4.9GW



2006

2008

2011

2012

2013

2014

2015

2016

2017

2018

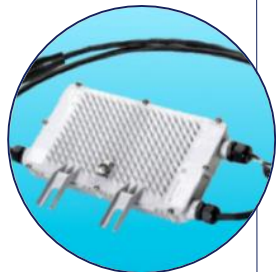

First microinverter
system introduced



1 million units shipped,
Enphase expands globally

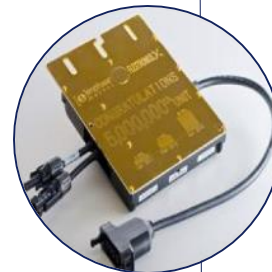

Fourth-generation
technology introduced



Sixth-generation
technology introduced



Seventh-generation
technology introduced

The Enphase Advantage

1 Enhanced Performance

- Enphase produces more power than any other inverter by 2-4%
- Higher energy harvest reduces utility bill

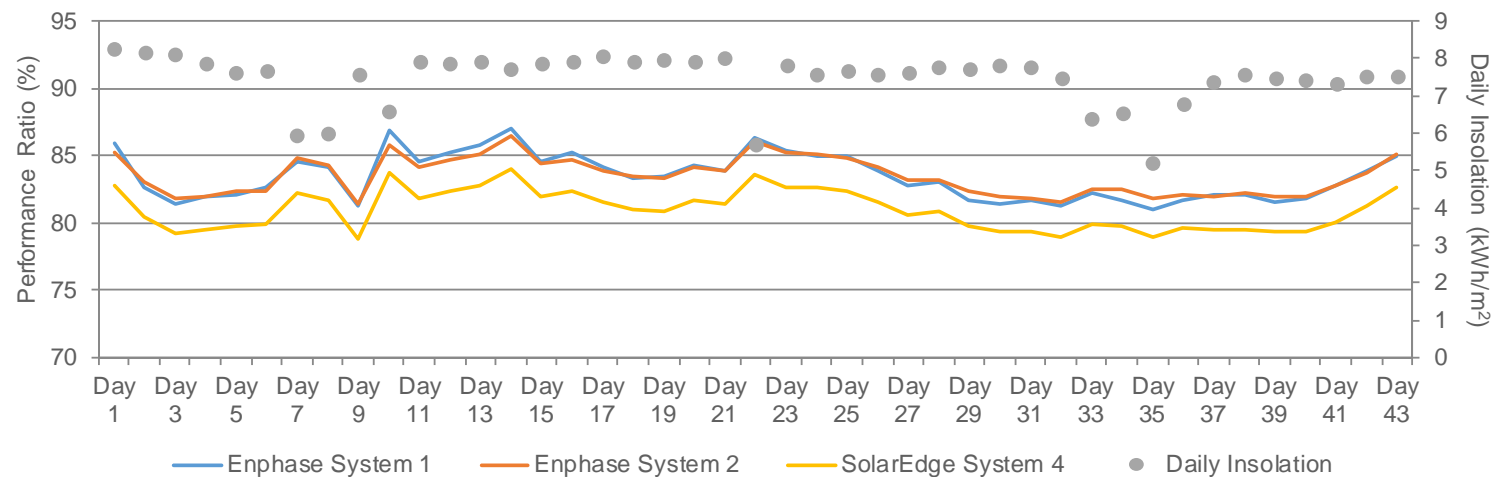

2 Superior Reliability

- Advanced technology enables increased uptime and lower O&M costs
- 1 million hours of testing



3 Simple Design + Installation

- Reduced time and cost for installers
- Lower upfront engineering design time and cost
- Lower installation time and cost



VS.



The Enphase Advantage

4 Safest Solar Inverter

- AC architecture provides homeowners peace of mind
- Very low voltage DC
- Much lower risk of arc faults



vs.



<https://youtu.be/zKtmPMjrbVA>

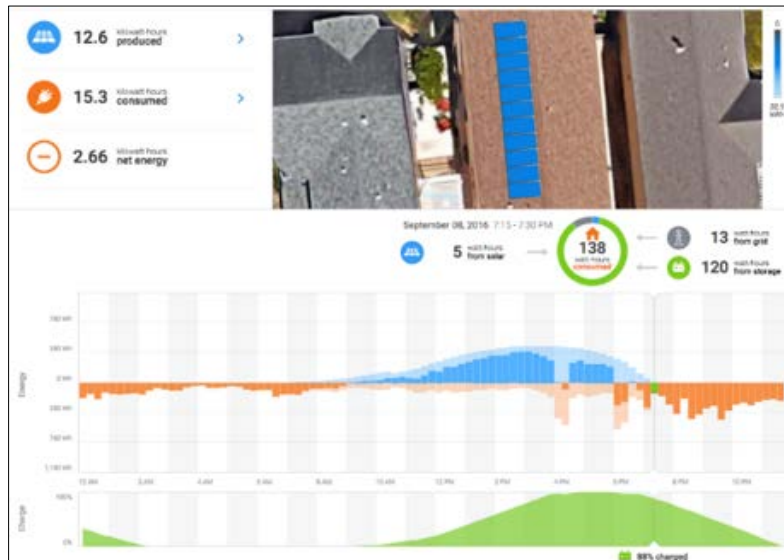

5 Intelligent Monitoring

- Intuitive monitoring
- Robust system provides 2-way communications
- Software designed hardware allows unprecedented flexibility and future proofing

