

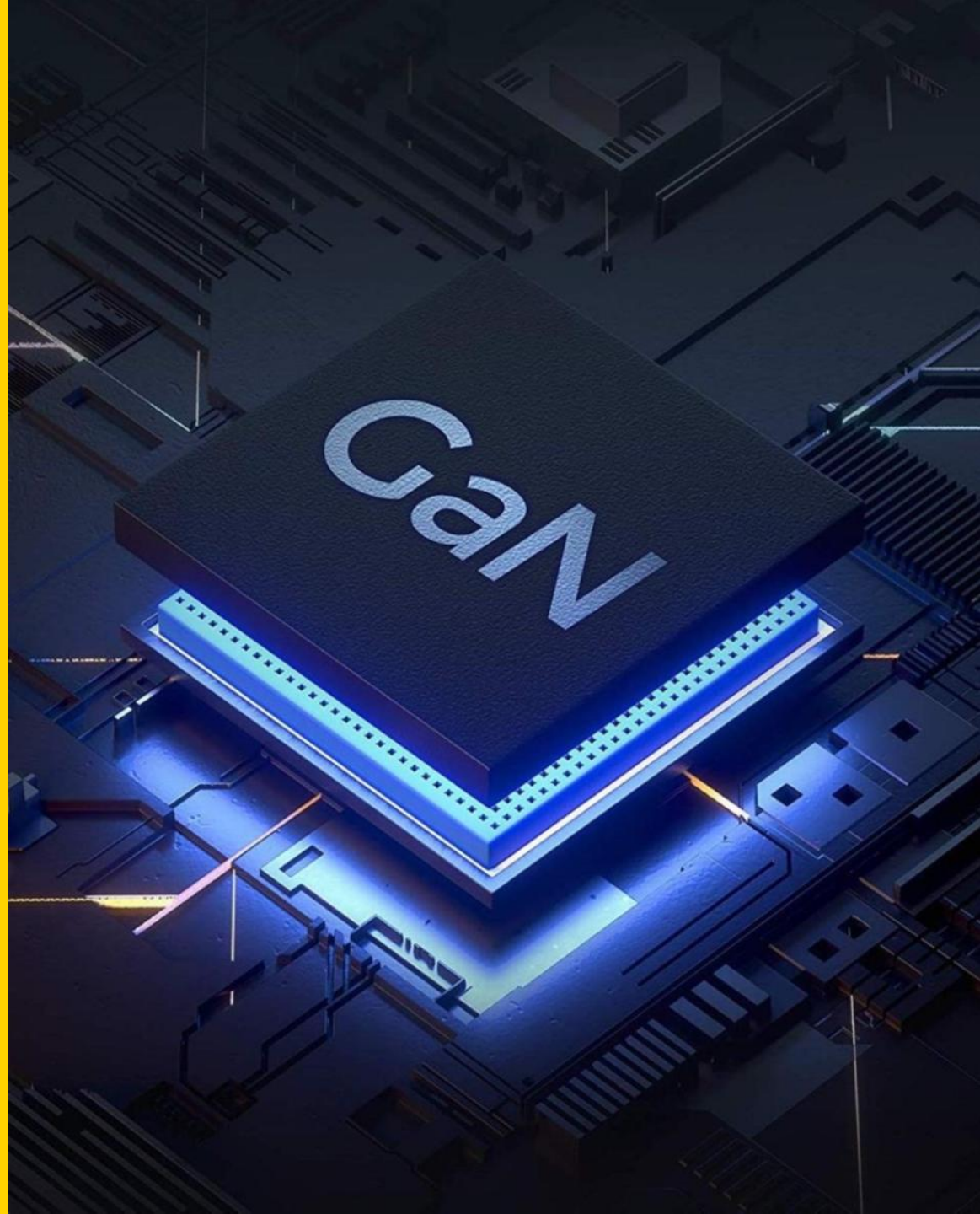

ST PowerGaN transistors



Improving energy efficiency while reducing total cost of ownership

GaN power devices enable outstanding power density, size reduction, and efficiency



>100 W/in³ power density

~50% average size reduction

98.6% PSU efficiency



>1 MHz switching frequency

$Q_{rr} = 0$; no reverse losses

10x better FoM than silicon

ST PowerGaN technology platforms

GaN-on-Silicon normally-off, based on p-GaN process

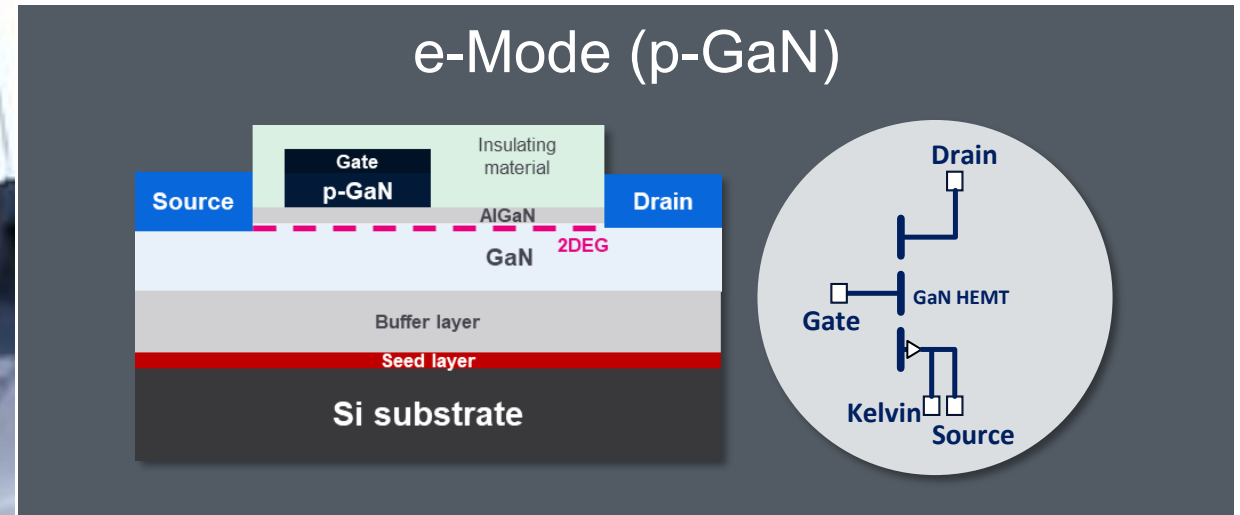
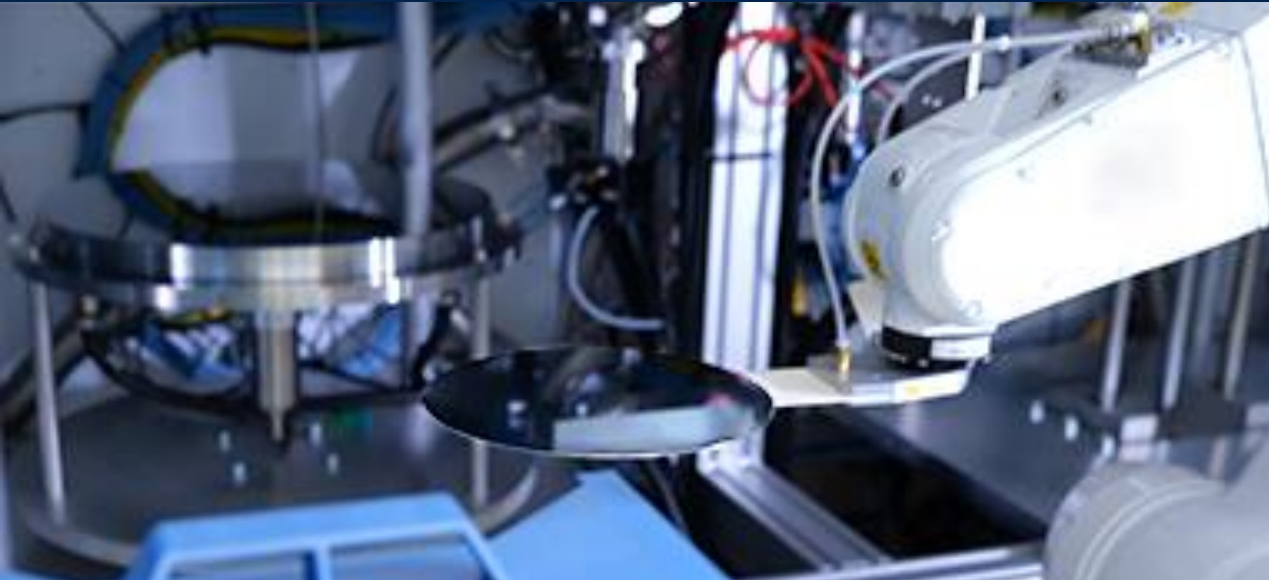

- Towards 8-inch wafer manufacturing with a vertically integrated process:
 - from GaN epitaxy to power device for LV/MV/HV
- Reliable supply chain
- Product differentiation through proprietary technology

PowerGaN range for various applications

Innovative solutions designed to meet different customer needs

Consumer and robotics



100 V 1.5-3.5 mΩ

EN-FCLGA



700 V

50-240 mΩ

PowerFLAT 8x8

PowerFLAT 5x6



- Mobile fast chargers
- Humanoid robots
- PC power supply
- Laptop adapter
- Gaming, home networking

AI servers and datacenters



100 V

1.5-3.5 mΩ

EN-FCLGA



700 V

23-70 mΩ

TOLL



TOLT



700 V BDS

15-70 mΩ

TOLT



QDPAK



- Rack PSU AC-48 V
- HVDC 800/50 V DC-DC converters
- Intermediate bus converter
- Point of load
- Battery backup unit DC-DC

Power and energy



100 V

1.5mΩ ... 3.5mΩ

EN-FCLGA



700 V

23mΩ ... 70mΩ

TOLL



700 V BDS

15mΩ ... 140mΩ

TOLT



- PV DC optimizers
- Residential solar microinverters
- Solid-state circuit breakers
- Energy storage systems

Automotive



100 V

1-3.5 mΩ

EN-FCLGA



700 V

23-70 mΩ

TOLL



700 V BDS

15-30 mΩ

QDPAK



1200 V

20-40 mΩ

QDPAK and power module



- 400 V OBC
- 800 V multilevel OBC
- 400-48 V DC-DC converter
- 48 V boardnet
- Traction inverter

Self-protected e-mode GaN HEMT with wide gate input voltage range

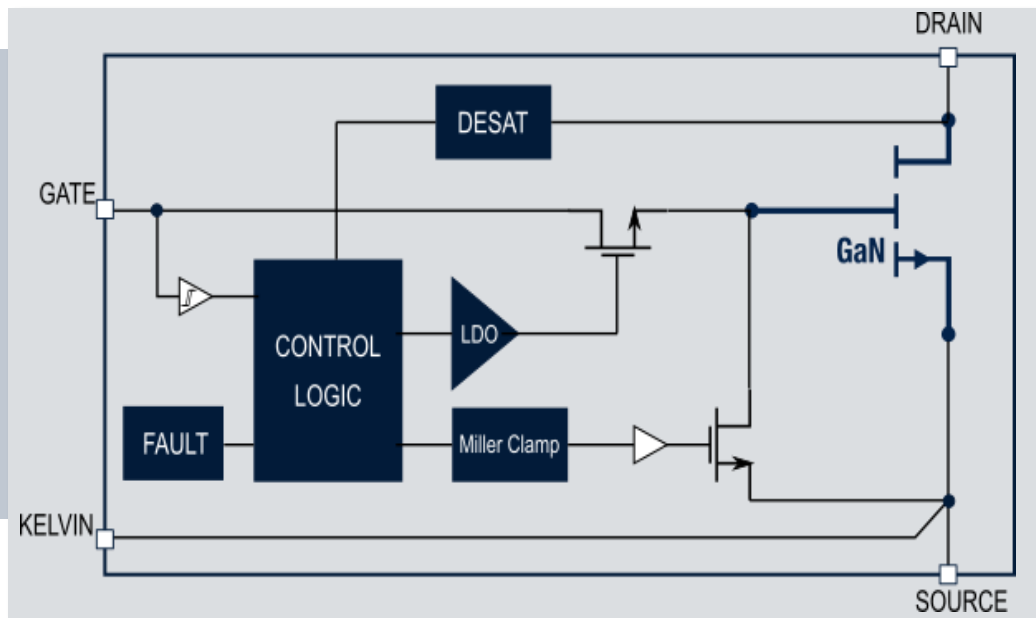

15 – 77 mΩ 700V E-mode GaN & 35 mΩ max 1200 V* E-mode
Integrated gate clamp
Wide 10 – 24 V gate input voltage range (LDO)
Compatible with standard Si/SiC drivers
Integrated Miller clamp
Paralleling capability
DESAT: short-circuit detection (300 ns)
OTP: Overtemperature protection
UVLO: Undervoltage lockout.

TO-LL

TOLT

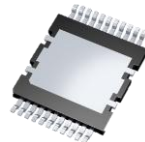
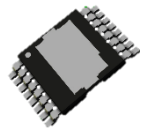

QDPAK



- High-power switching power supply
- AC-DC, DC-DC, DC-AC converters
- Solar microinverter, motor drive, **OBC**

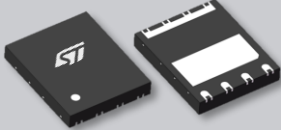

Packages for PowerGaN

PowerFLAT 5x6 BSC	PowerFLAT 8x8 BSC	TO252-DPAK
		
<p>Smallest footprint for HV GaN TAB connected to SOURCE Low package profile 5.00 x 6.00 x 0.85 mm Multiple sources Kelvin source pin for optimized driving</p>	<p>Larger exposed metal on bottom side TAB connected to SOURCE Low package profile 8.00 x 8.00 x 0.90 mm Multiple sources Kelvin source pin for optimized driving</p>	<p>Cost-effective solution TAB connected to SOURCE Well establish industry standard 6.60 x 10.10 x 2.30 mm Multiple sources</p>

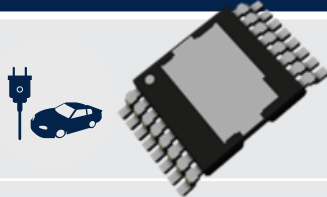
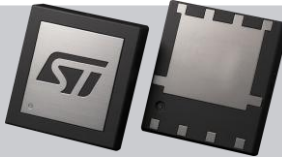
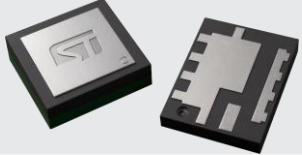
TO-LL	TOLT	EN-FCLGA 5x6	EN-FCLGA 3.3x3.3
			
<p>Flexible solution TAB connected to SOURCE Well established in server & telecom 9.9 x 11.68 x 2.30 mm Multiple sources Kelvin source pin for optimized driving</p>	<p>Exposed metal on top TAB connected to SOURCE Unidirectional and bidirectional 10 x 15 x 2.30 mm Multiple sources Kelvin source pin for optimized driving</p>	<p>Exposed metal on top and bottom Bottom TAB connected to DRAIN Pin to pin with Si MOSFETs 5 x 6 x 0.87 mm Package level</p>	<p>Exposed metal on top and bottom Bottom TAB connected to SOURCE Pin to pin with Si MOSFETs 3.3 x 3.3 x 0.87 mm Package level</p>

Support material

 [Product web page](#)

 [Spice models](#)

 [Datasheet](#)

 [Specter models](#)

 [Application notes](#)

 [Product selector](#)

 [Technical notes](#)

Our technology starts with You



Find out more at www.st.com

© STMicroelectronics - All rights reserved.

ST logo is a trademark or a registered trademark of STMicroelectronics International NV or its affiliates in the EU and/or other countries.

For additional information about ST trademarks, please refer to www.st.com/trademarks.

All other product or service names are the property of their respective owners.

