



life.augmented

STPM801 - Hot Swap & Ideal Diode Controller for high redundancy power architectures

June 2023 v.2

Highlights

Power Management ICs (PMICs and STPM801)

- ST provides a large selection of Power Management ICs specifically designed for automotive electronic systems.
- PMICs are a fundamental component for powering automotive systems composed of MCU, SoC, memories, communication buses and peripherals, because they allow the reduction of the system size and provide the functions that a complex system cannot do without: pre-regulation, post-regulation, voltage sequencing and monitoring, communication bus (SPI), diagnostics, etc... In addition, some PMICs meet the functional safety requirements (ASIL) that critical applications (ADAS) must target, which discrete solutions may struggle to meet.
- One of the challenges safety relevant applications face is to provide voltage and current protection during fault events. These include short-circuit, overcurrent, overvoltage, undervoltage, and temperature. Furthermore, in electric cars where systems are always under supply, when a device is inserted or removed from a live supply, it is possible to see very large current spikes during capacitor charging. STPM801, with a hot-swap controller, ensures the safe insertion of these systems. The Ideal diode controller integrated in STPM801 can also protect against reverse polarity conditions, caused by connecting a battery incorrectly or mis-wiring a power supply. Its Oring controller allows the power redundancy with two power supplies connected to a single load.

hot swap & ORing IC for high redundancy power architectures

STPM801 offers integrated Hot-Swap, Soft-Start and OR-ing and reverse input protections. It protects load from high voltage transients, OV and UV, and allows the use of the backup battery.

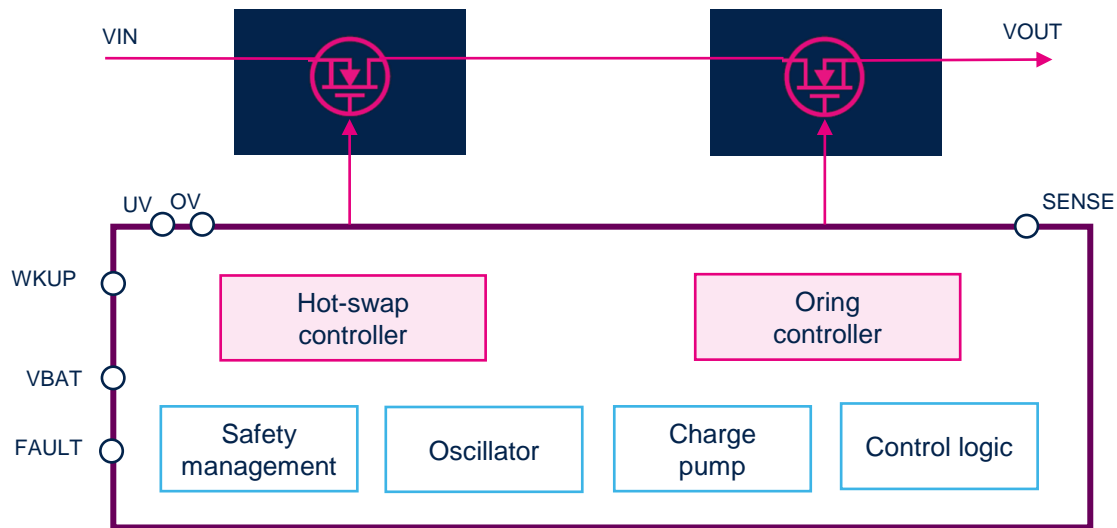

- Wide input voltage, from 4V to 65V, with -65V reverse protection
 - Full function operating input voltage from 4V to 40V
- 2x external N-channel MOSFET pre-drivers: 1x hot-swap + 1x o-ring
- Soft start: control of hot-swap, adjustable by external capacitor
- Input overvoltage and undervoltage protections (threshold with ext divider)
- Fault pin: LOW whenever a fault condition is detected (i.e. OV, UV, OVC). Fault Table in the datasheet
- Stand-by mode with reduced power consumption (50uA)
- Output overcurrent protection
- Short to GND detection on Vout
- Complies with the 16750 AC ripple test requirements (50-25kHz)

STPM801 supports ASIL-D applications

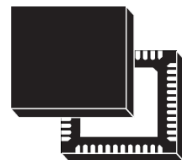

**Package:
VFQFN32+4L
(5x5mm)**

Applications

- ADAS
- Automotive Body
- Connected & Infotainment
- Safety

Description

The two N-channel transistors driven by the device are, respectively, the Hot Swap and the Oring MOSFETs. The first is used as a normal power switch; the Soft Start function helps to limit the inrush current during the device power-up. The Oring MOSFET is mainly used as ideal diode, helps blocking the current conduction in case of reverse battery detection and meeting automotive ISO transient requirements.

Application example with redundancy battery

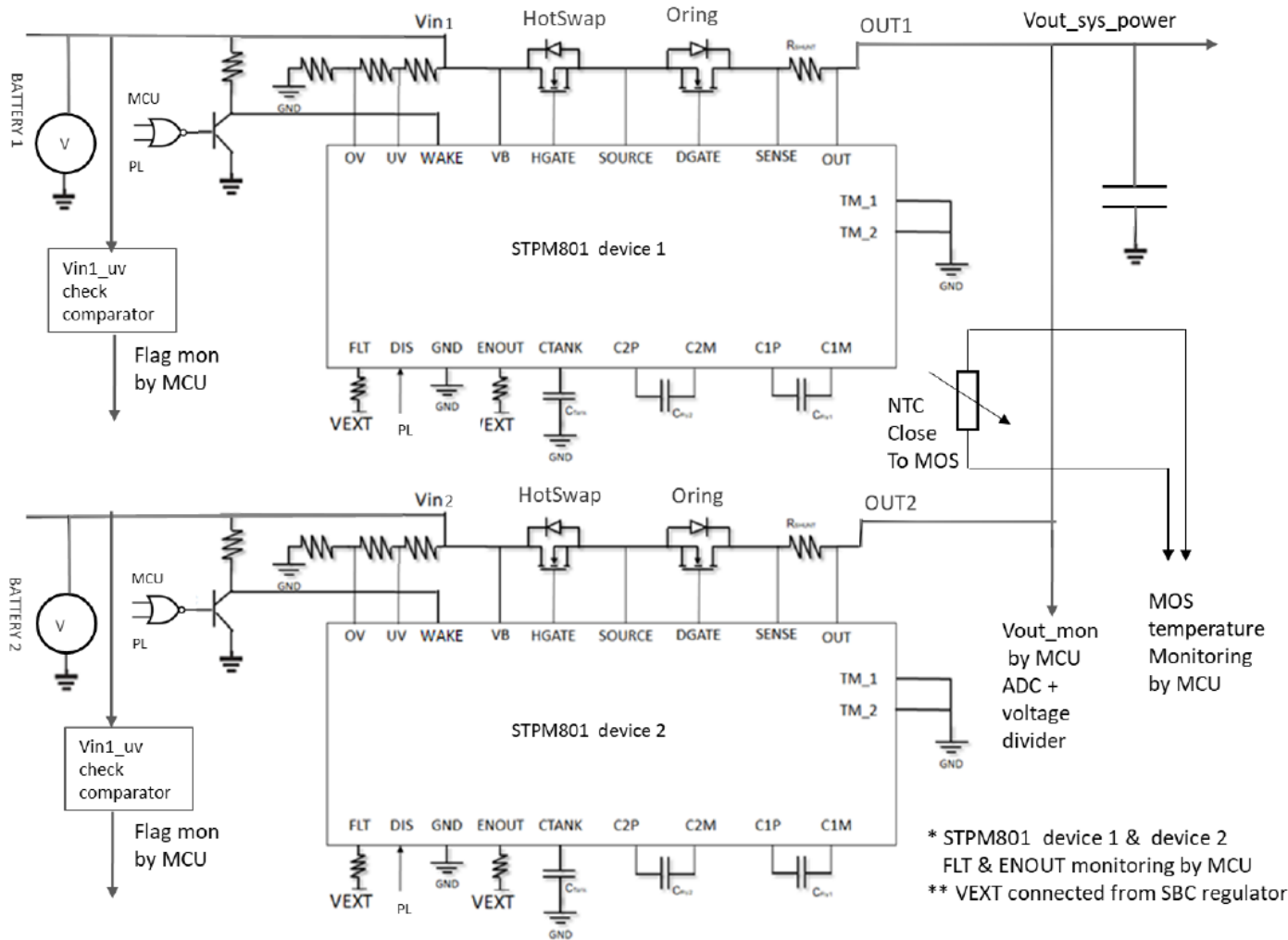

OR-ING FUNCTION

The output voltage is the OR between battery 1 and battery 2. The highest battery voltage is transferred to the output, while the lowest is blocked by the ideal diode, since a reverse condition is detected.

STPM801 can also work with a single battery, if the OR-ing function is not required

Pin and device functions

• Soft Start

In order to avoid huge inrush currents at the device power-up, the Soft-Start function is realized for the control of **Hotswap** switch-ON.

A capacitor C is connected to HGATE, and it is charged by STPM801 by a constant current of 37 μ A. It means that the transient switch ON is controlled by

$$\frac{dv}{dt} = \frac{37 \mu A}{C}$$

The higher is C value, the slower is the transient.

• Input pin for device control

STPM801 can reach a safe-state (meaning both pre-drivers turned OFF) also by acting on two digital inputs:

DIS (digital input): when it is HIGH, both pre-drivers are actively switched OFF but the device remains supplied;

WAKE (analog input): when WAKE is LOW, it triggers the turn off of the device including internal supply parts. In this way device is in shut down and it is not able to drive the pin.

• OVC detection

OVC is detected monitoring the voltage drop across a shunt resistor (typically 1 m Ω) placed between OUT and SENSE pin.

STPM801 allows to adapt **filter time** and the **thresholds**, depending if a short to GND is also detected, and if, after a first detection, the current goes on increasing.



• Battery UV and OV control

STPM801 is compatible with 12V and 24V systems.

Depending on the application, the user can program the thresholds for UV and OV detection simply acting on the resistors partitioning connected to UV and OV pin.

The partitioning result is compared with the internal reference voltage of the device ($\approx 1,2$ V of bandgap)

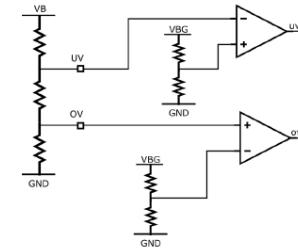

• Digital output pin

FLT: it is normally HIGH. The device brings it LOW whenever a fault condition is detected (i.e. OV, UV, OVC). Fault Table on the datasheets shows which faults are redirected on FLT. It is normally used by external MCU for managing faulty conditions

ENOUT: It is high when the voltage at the OUT pin is above ($V_B - 0.8V$), indicating that the external MOSFETs are fully on. It is normally LOW only during device power-up.

STPM801 ID card

Product description

STPM801 is an Ideal Diode Controller with hot swap, soft start, OR-ing and reverse battery protection for redundant power architectures.

Key features

- Wide input voltage range: 4 V to 65 V
- Reverse input protection -65 V
- 2 external N-channel MOSFET pre-drivers
- Quiescent current < 50 μ A if WAKE low
- Input overvoltage & undervoltage protection
- Output overcurrent protection
- Complies with the 16750 AC ripple test requirements (50 Hz - 25 kHz)
- Adjustable soft start with external capacitor
- Developed according to ISO 26262 to support ASIL D application
- AEC-Q100 qualified

Elevator pitch (Value proposition, problem solved)

Simplifies input protection design and power path sequencing by integrating a variety of features into a single device.
Versus discrete approach, it replaces large and inefficient discrete components (Schottky Diodes, P-ch MOSFETs), with added intelligence to support functional safety.

ST's competitive edge

- Hot swap and OR-ing functions integrated into a single device
- Wide operating range enabling usage in 12V and 24V systems
- Functional safety capable supporting ASIL-D applications

Applications

- Zonal/Body ECUs
- ADAS ECUs
- High Performance Compute ECUs
- Infotainment ECUs
- Redundant Power Delivery
- Dual Battery Systems



Thank you

© STMicroelectronics - All rights reserved.

ST logo is a trademark or a registered trademark of STMicroelectronics International NV or its affiliates in the EU and/or other countries.

For additional information about ST trademarks, please refer to www.st.com/trademarks.

All other product or service names are the property of their respective owners.



life.augmented