

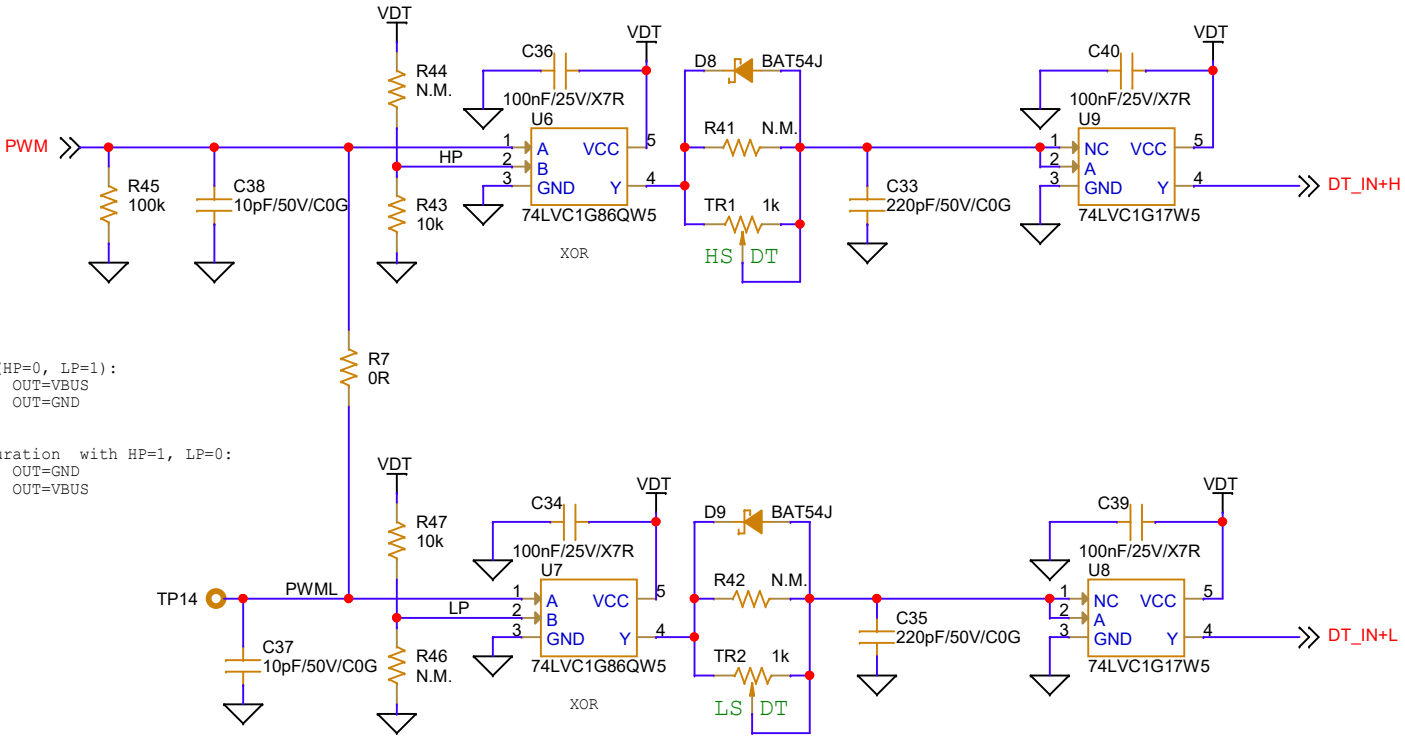

Gate driver supply voltage selection:
 5V: R28 closed, R31 open, R30 don't care
 3.3V: R28 open, R31 closed, R30 240R
 External: R28, R31, R30 all open
 Note: DCDCs shall be supplied at 5V

	Default	HB=0	HB=1
PWMH=0	HIN=0	HIN=1	HIN=0
PWMH=1	HIN=1	HIN=0	HIN=1
	Default	LB=1	LB=0
PWML=0	LIN=1	LIN=0	LIN=1
PWML=1	LIN=0	LIN=1	LIN=0



Default board configuration (HP=0, LP=1):
 PWMH=PWML=0 --> HIN=0, LIN=1, OUT=VBUS
 PWMH=PWML=1 --> HIN=1, LIN=0, OUT=GND

To set PWMx=0 --> OUT=GND
 use alternative board configuration with HP=1, LP=0:
 PWMH=PWML=0 --> HIN=1, LIN=0, OUT=GND
 PWMH=PWML=1 --> HIN=0, LIN=1, OUT=VBUS

 life.augmented	Board Title EVSTGAP2GS-R1		This drawing and the information herein are property of STMicroelectronics and are intended for evaluation purpose only	
	Sheet Title 3 - Dead Time			
	Doc No	Date Thursday, May 18, 2023	Rev R1.0	Sheet 3 / 3