



Figure 2. STDES-50KWPVDRV gate driver board - circuit schematic (2 of 2)

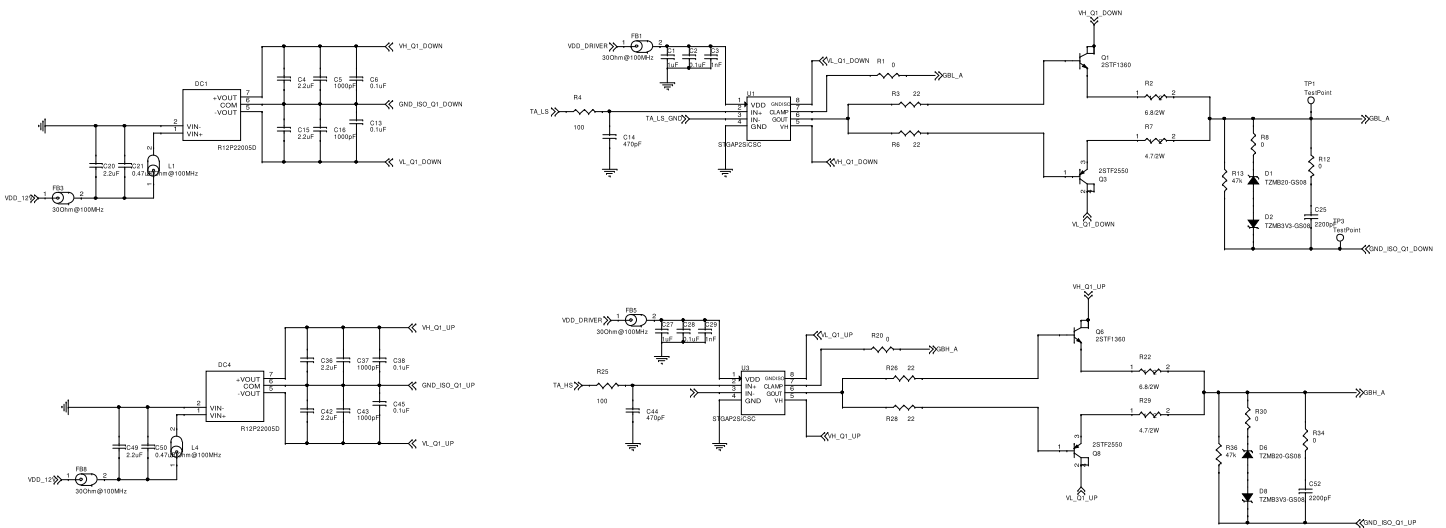

Figure 3. STDES-50KWPVPR main power board - circuit schematic (1 of 13)

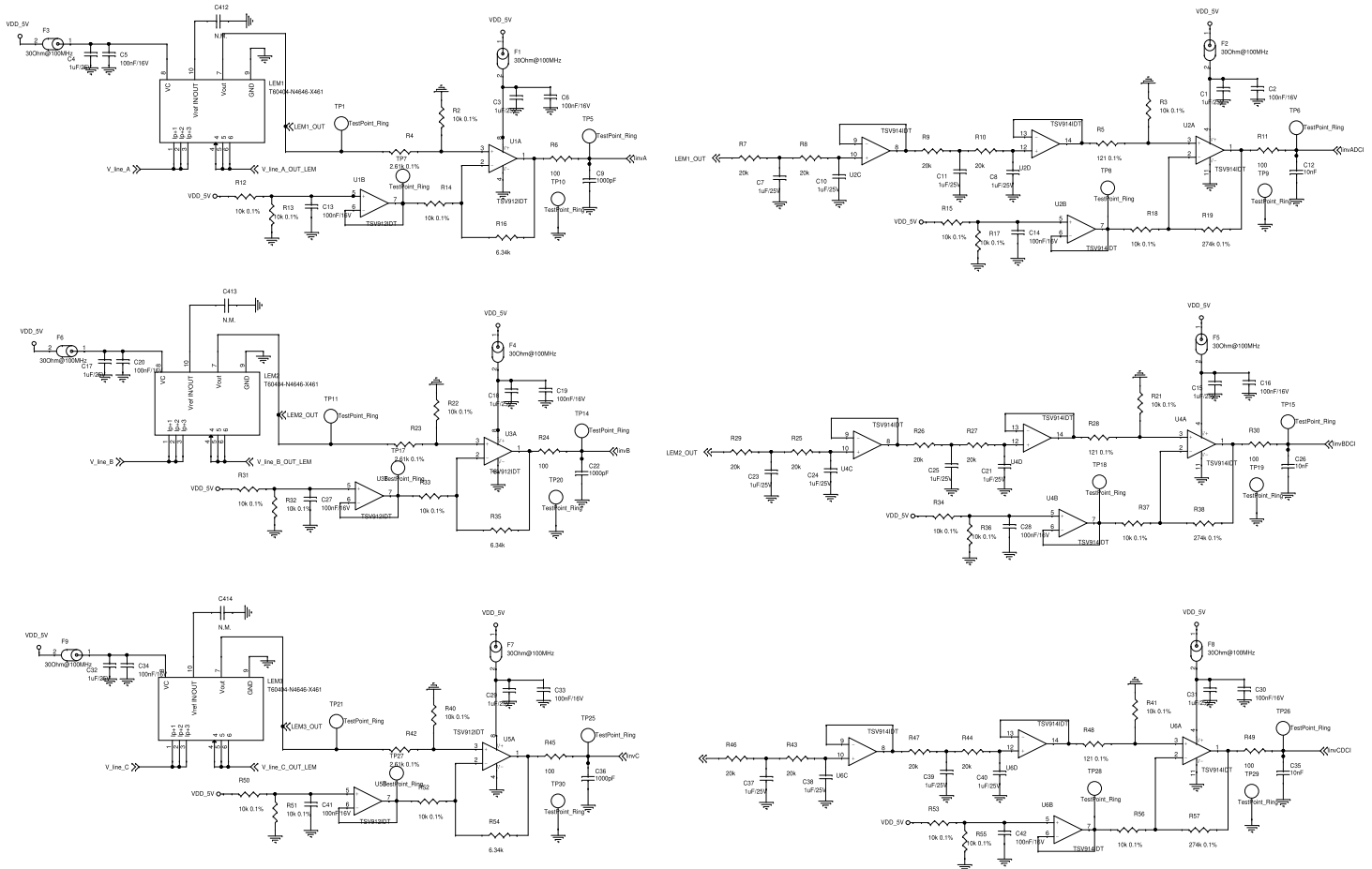

Figure 4. STDES-50KWPVPWR main power board - circuit schematic (2 of 13)

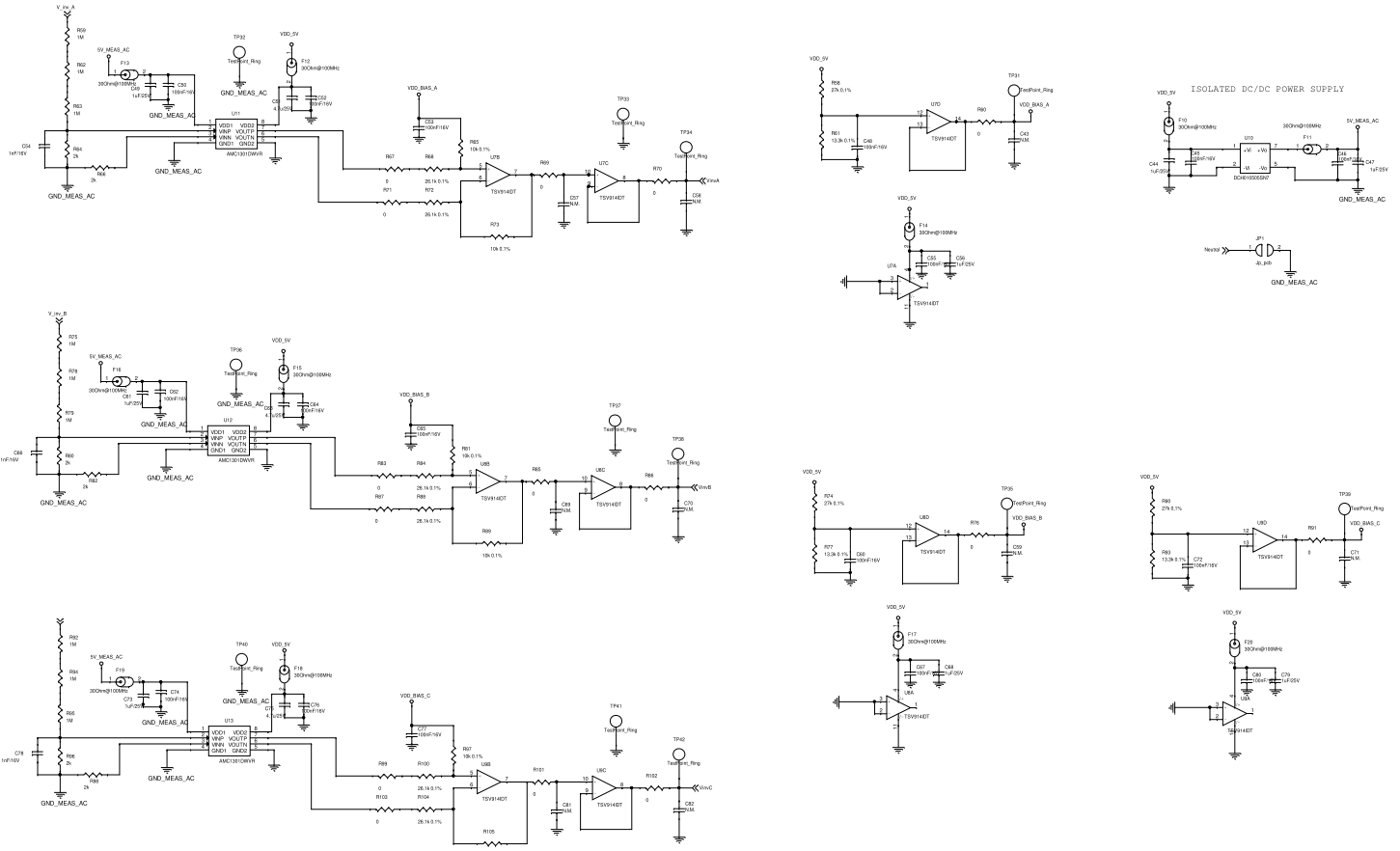

Figure 5. STDES-50KWPVPWR main power board - circuit schematic (3 of 13)

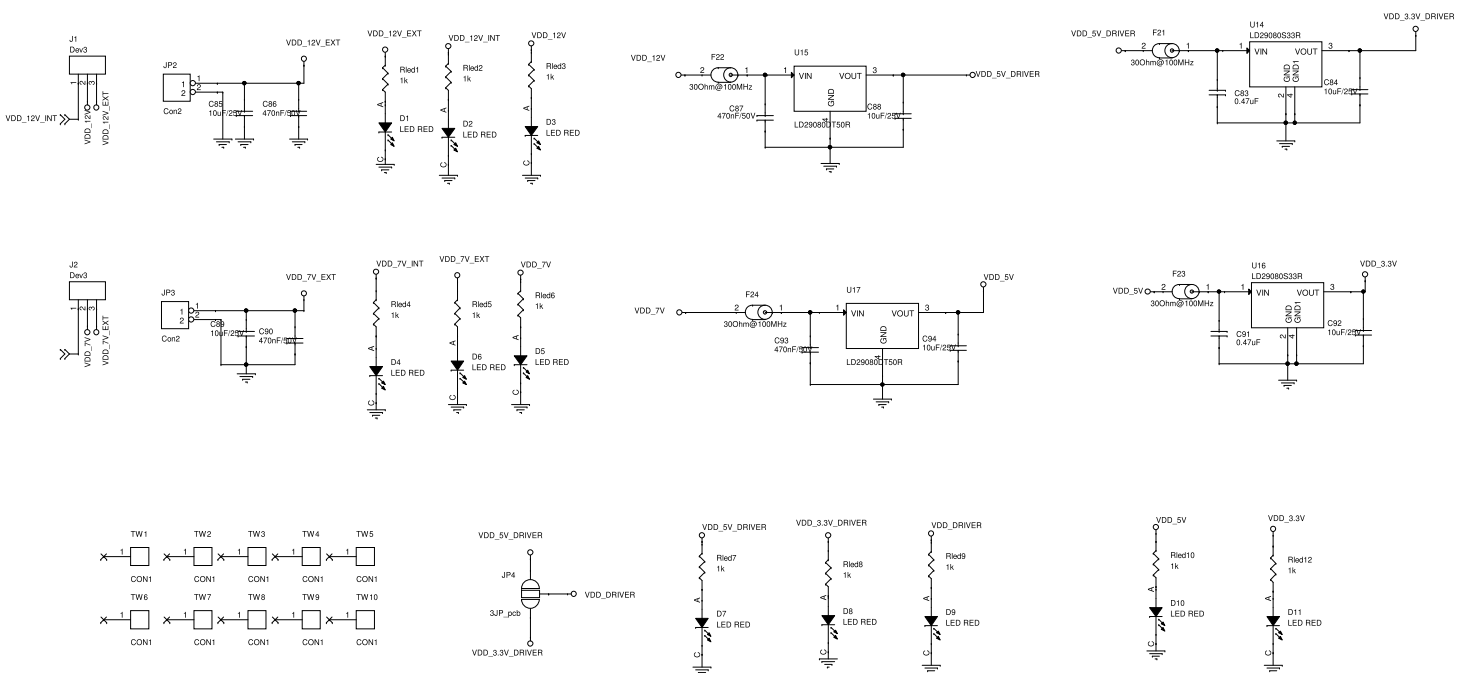

Figure 6. STDES-50KWPVPR main power board - circuit schematic (4 of 13)

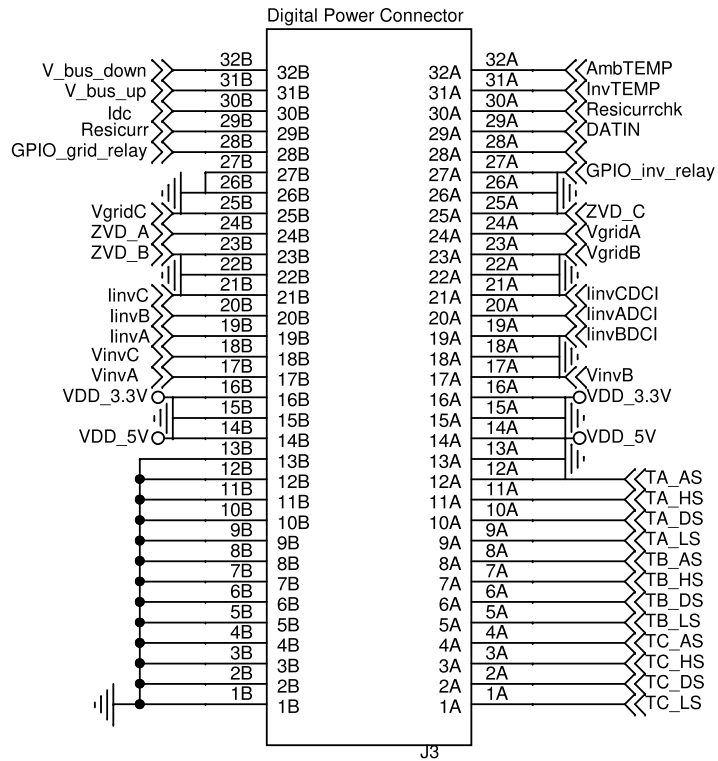

Figure 7. STDES-50KWPVPR main power board - circuit schematic (5 of 13)

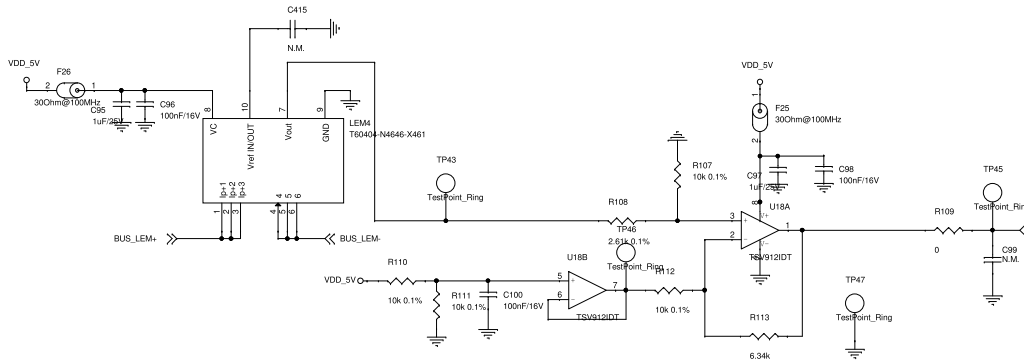

Figure 8. STDES-50KWPVPR main power board - circuit schematic (6 of 13)

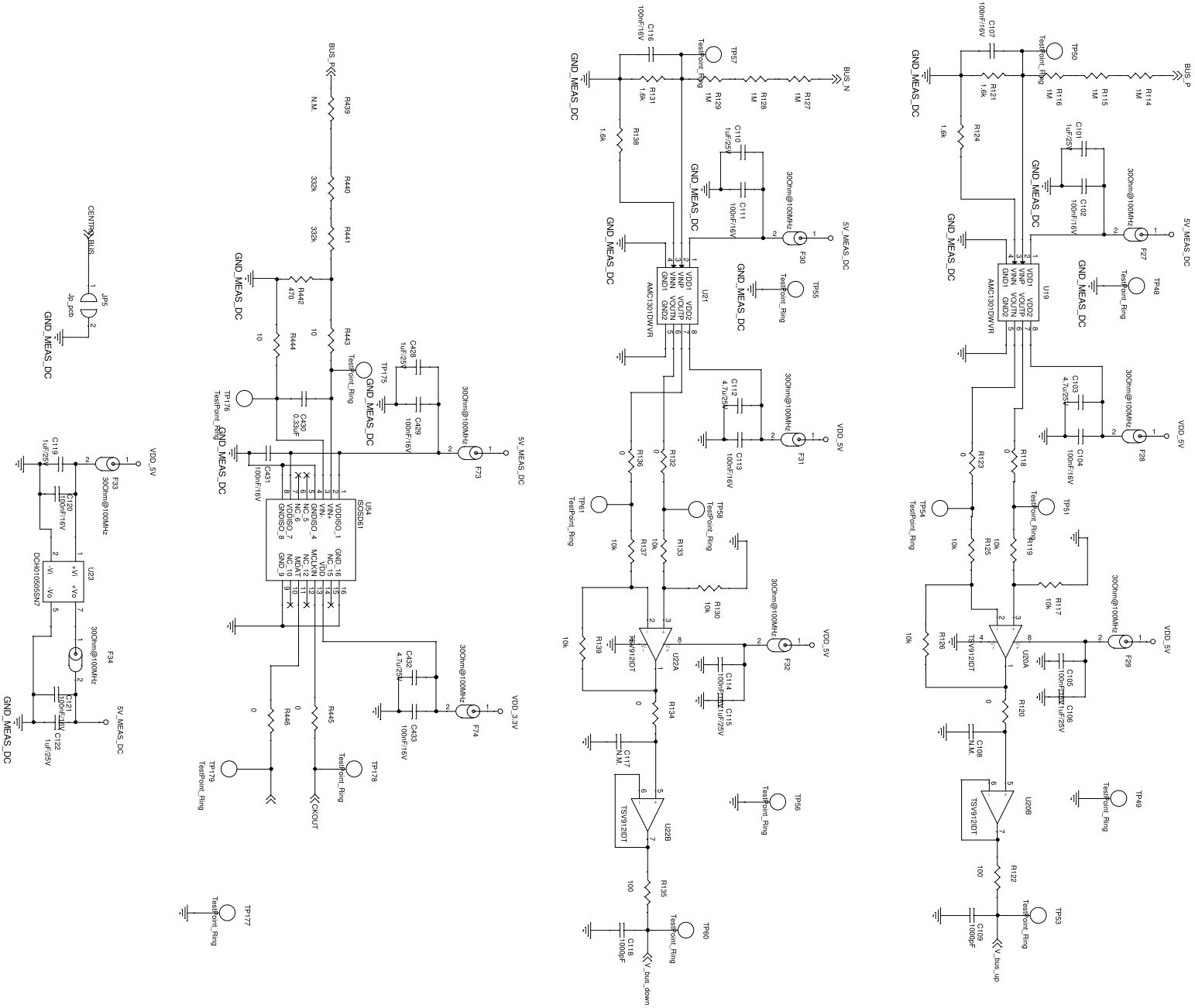

Figure 9. STDES-50KWPVPWR main power board - circuit schematic (7 of 13)

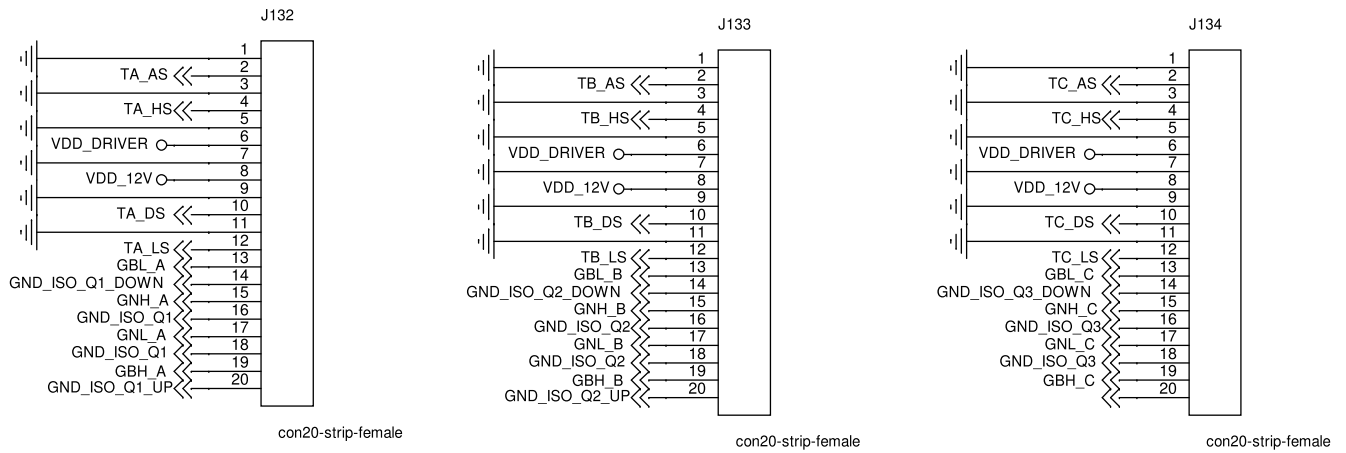



Figure 11. STDES-50KWPVWR main power board - circuit schematic (9 of 13)

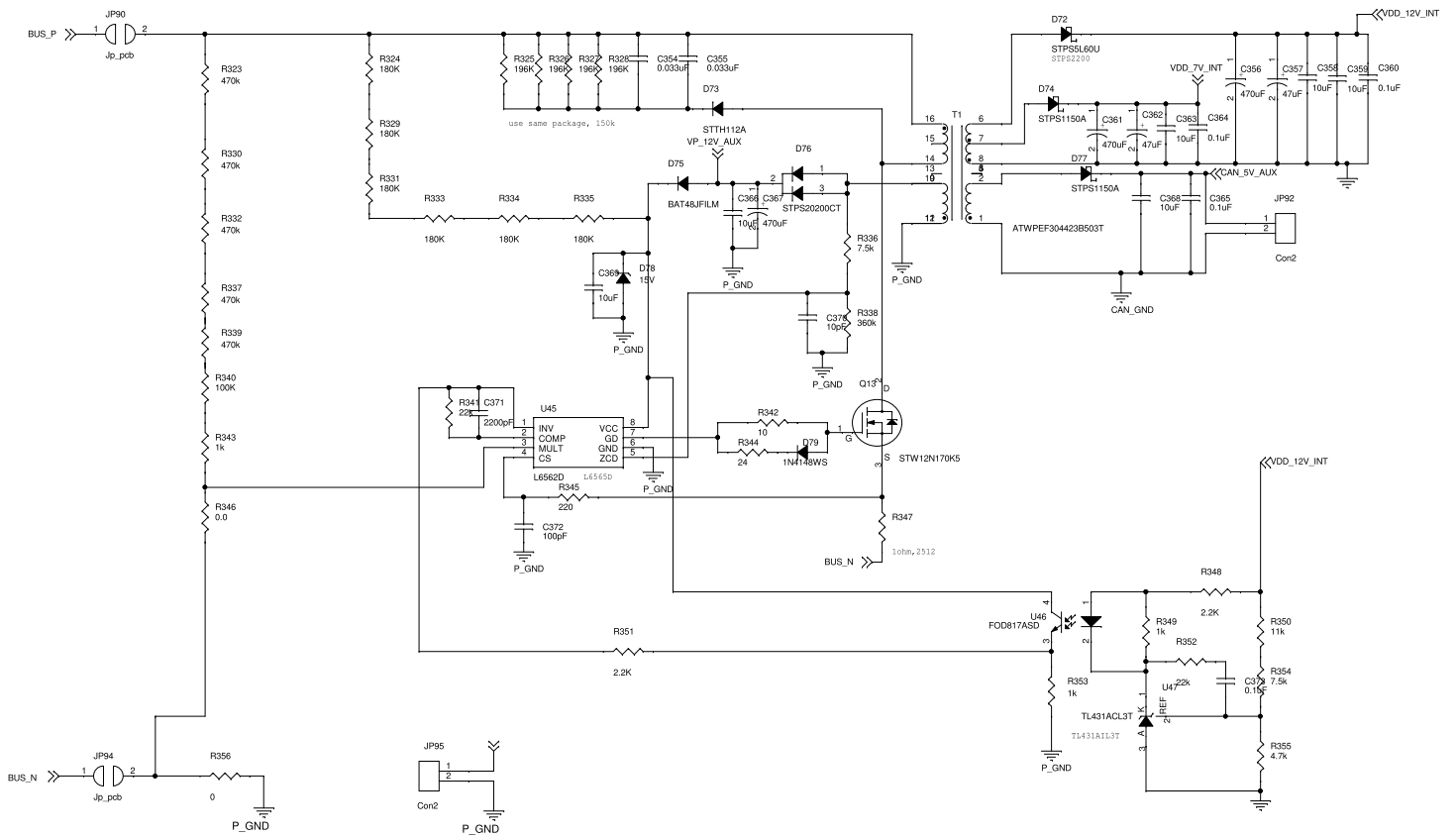

Figure 12. STDES-50KWPVPWR main power board - circuit schematic (10 of 13)

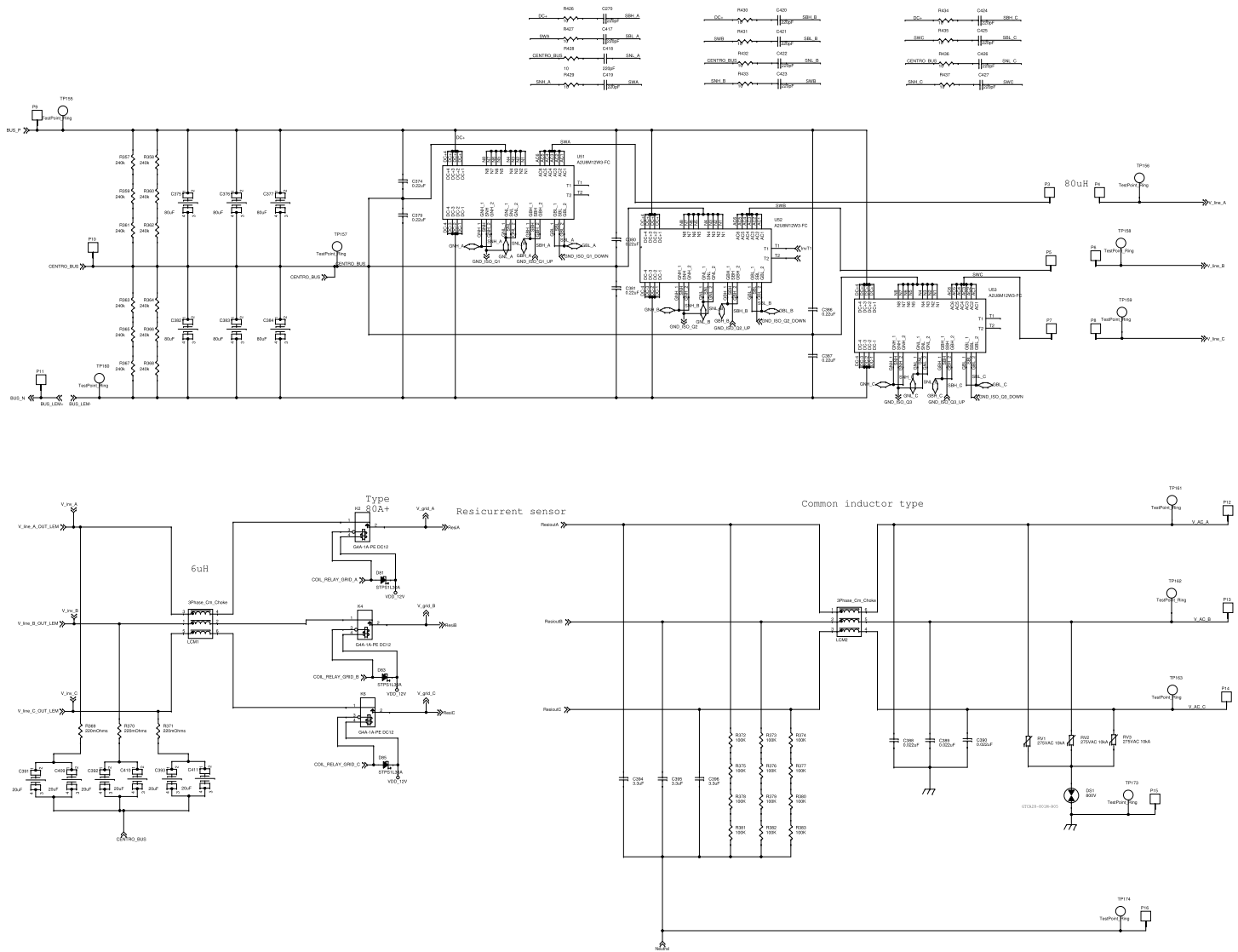



Figure 15. STDES-50KWPVWR main power board - circuit schematic (13 of 13)

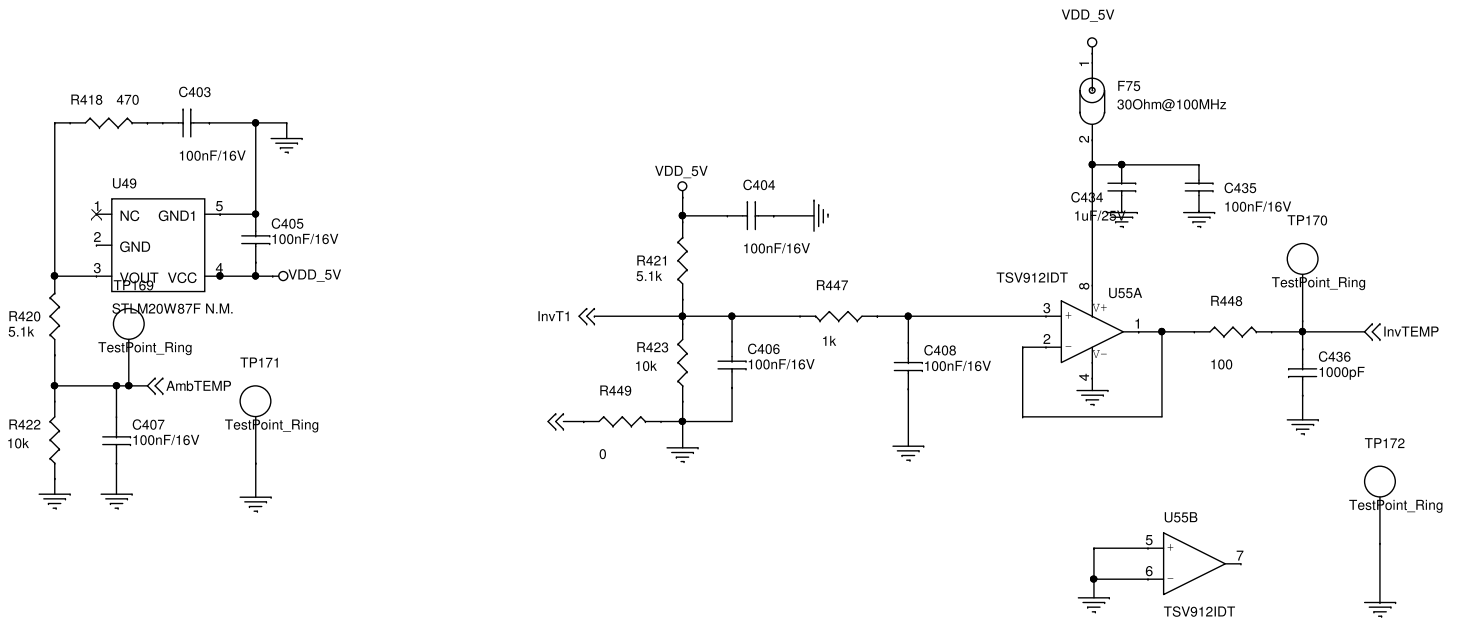

Figure 16. STDES-H743CTRL control board - circuit schematic (1 of 5)

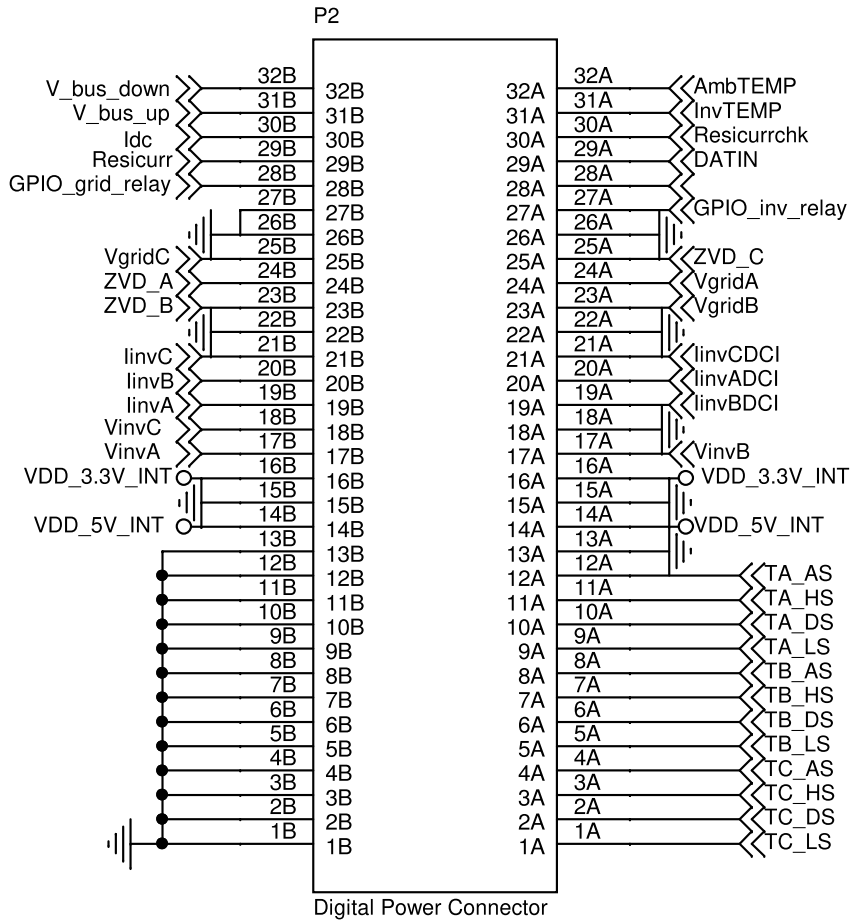

Figure 17. STDES-H743CTRL control board - circuit schematic (2 of 5)

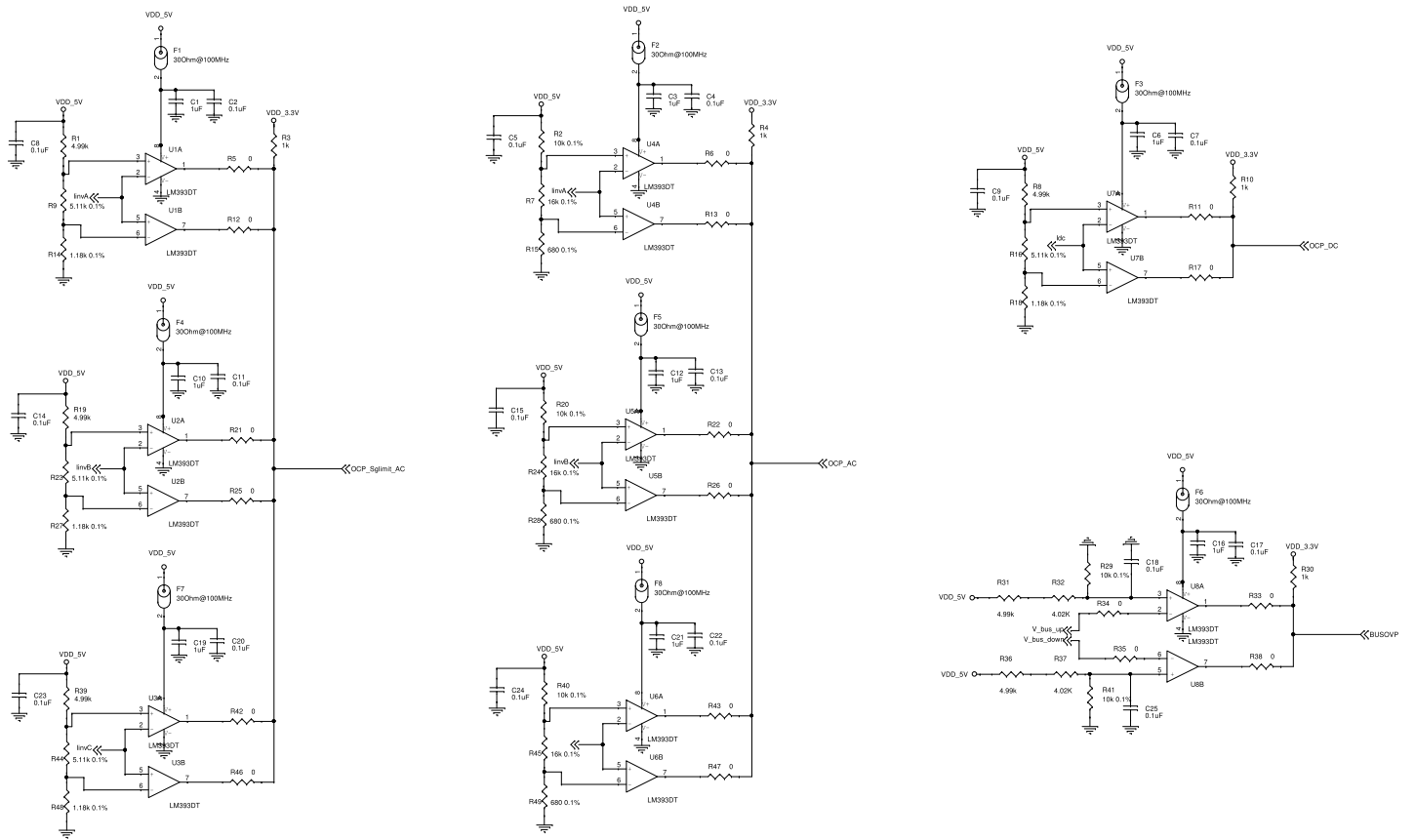

Figure 18. STDES-H743CTRL control board - circuit schematic (3 of 5)

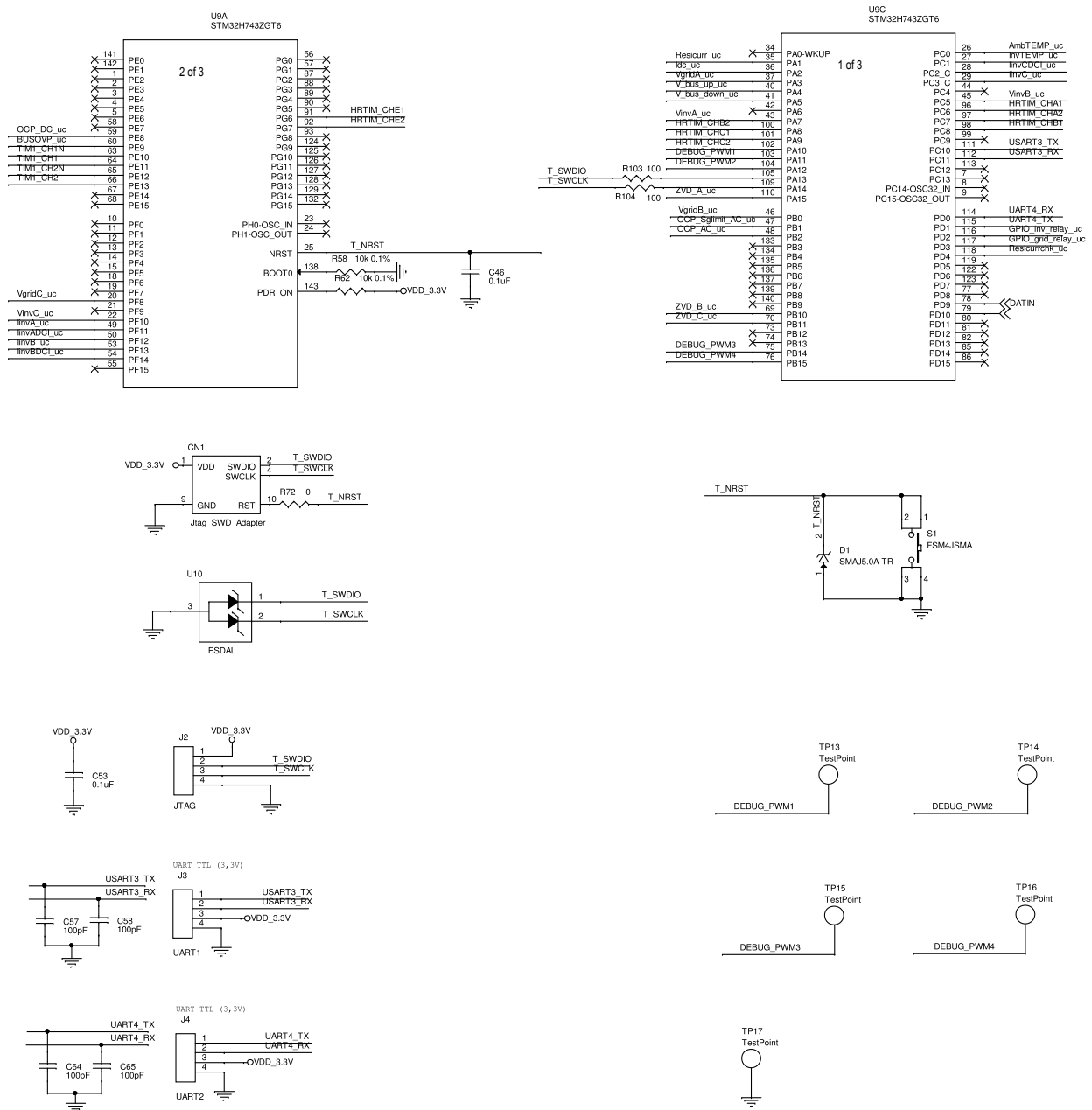

Figure 19. STDES-H743CTRL control board - circuit schematic (4 of 5)

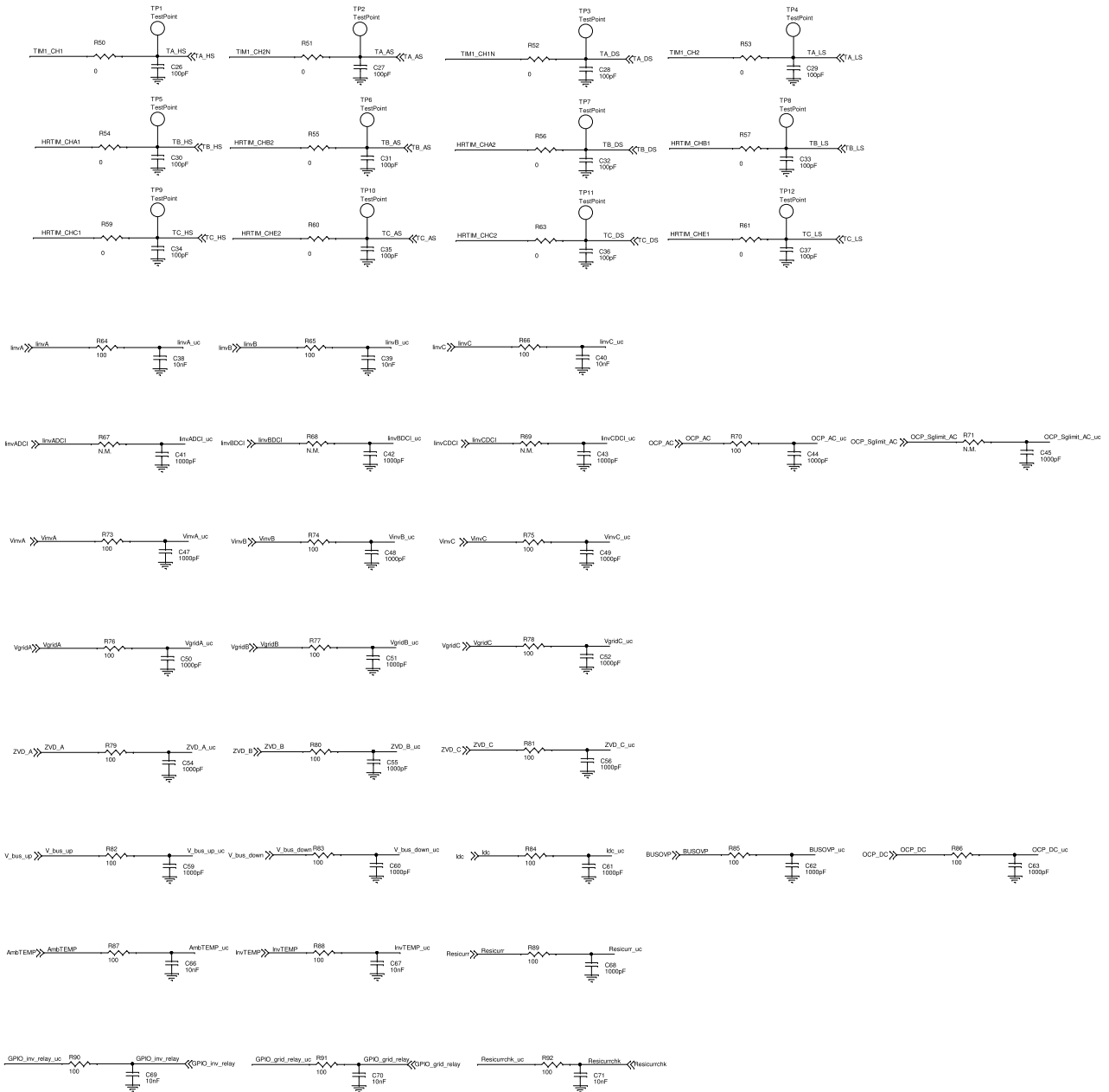
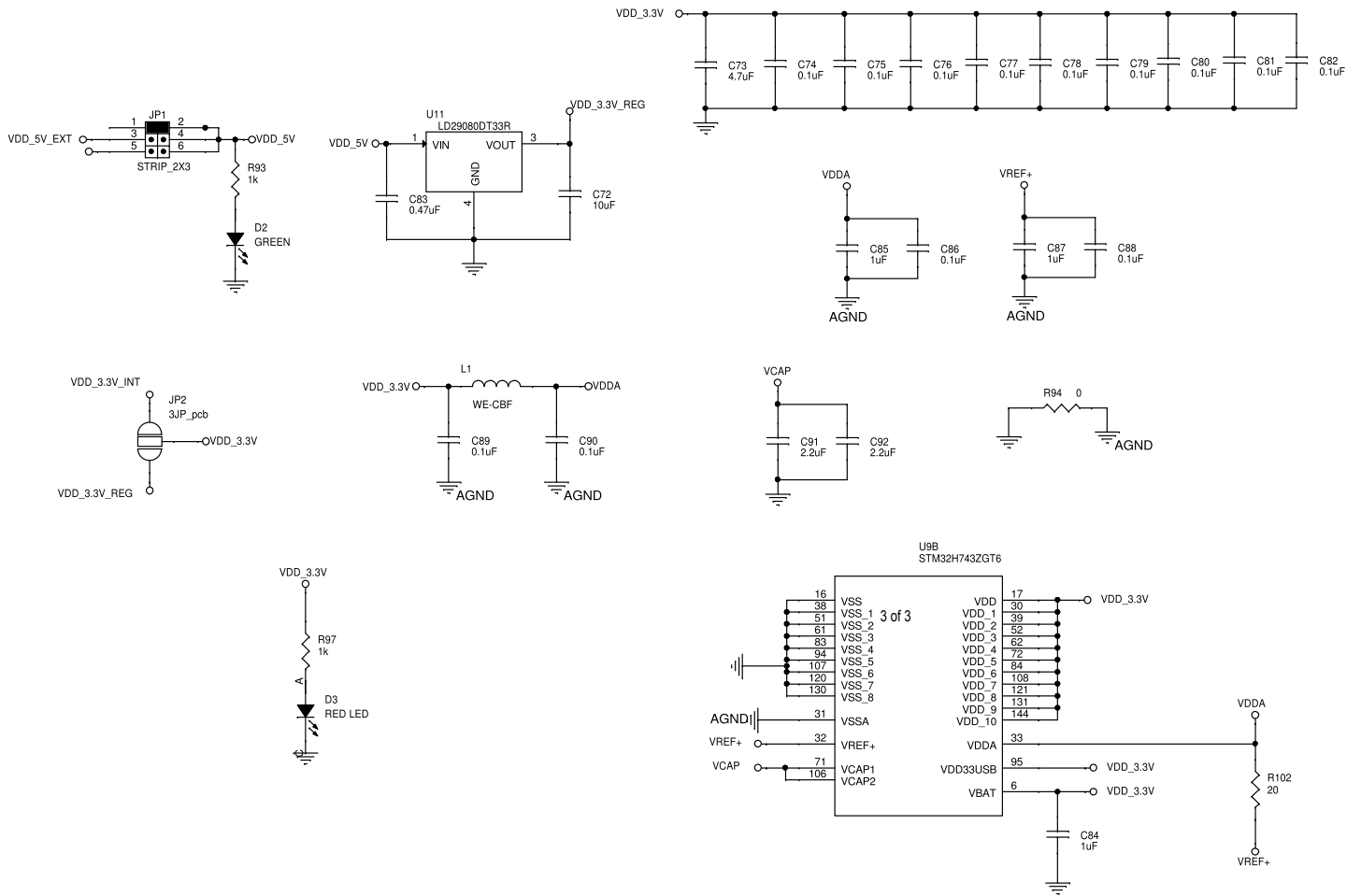

Figure 20. STDES-H743CTRL control board - circuit schematic (5 of 5)



**IMPORTANT NOTICE – READ CAREFULLY**

STMicroelectronics NV and its subsidiaries (“ST”) reserve the right to make changes, corrections, enhancements, modifications, and improvements to ST products and/or to this document at any time without notice.

In the event of any conflict between the provisions of this document and the provisions of any contractual arrangement in force between the purchasers and ST, the provisions of such contractual arrangement shall prevail.

The purchasers should obtain the latest relevant information on ST products before placing orders. ST products are sold pursuant to ST’s terms and conditions of sale in place at the time of order acknowledgment.

The purchasers are solely responsible for the choice, selection, and use of ST products and ST assumes no liability for application assistance or the design of the purchasers’ products.

No license, express or implied, to any intellectual property right is granted by ST herein.

Resale of ST products with provisions different from the information set forth herein shall void any warranty granted by ST for such product.

If the purchasers identify an ST product that meets their functional and performance requirements but that is not designated for the purchasers’ market segment, the purchasers shall contact ST for more information.

ST and the ST logo are trademarks of ST. For additional information about ST trademarks, refer to [www.st.com/trademarks](http://www.st.com/trademarks). All other product or service names are the property of their respective owners.

Information in this document supersedes and replaces information previously supplied in any prior versions of this document.

© 2026 STMicroelectronics – All rights reserved