

Schematic diagrams

Figure 1. STEVAL-SILKTA01 circuit schematic (1 of 21)

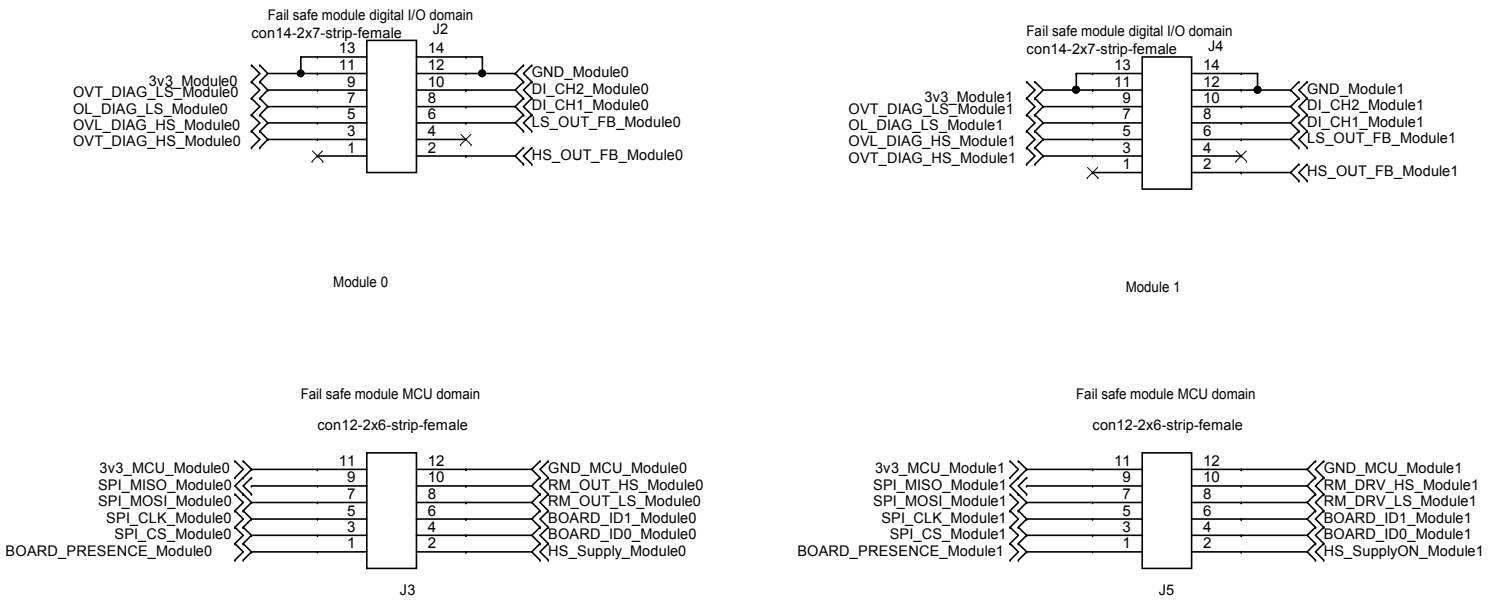

Figure 2. STEVAL-SILKTA01 circuit schematic (2 of 21)

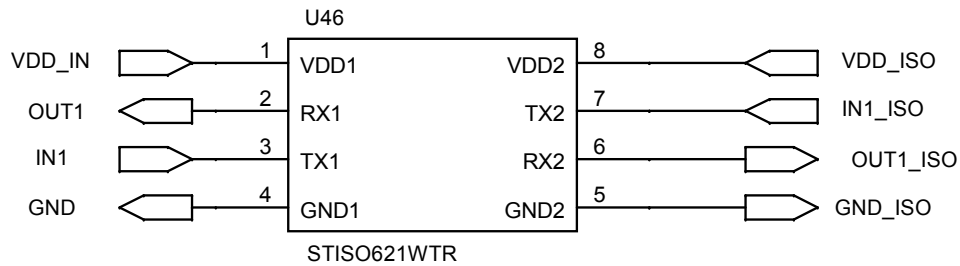

Figure 3. STEVAL-SILKTA01 circuit schematic (3 of 21)

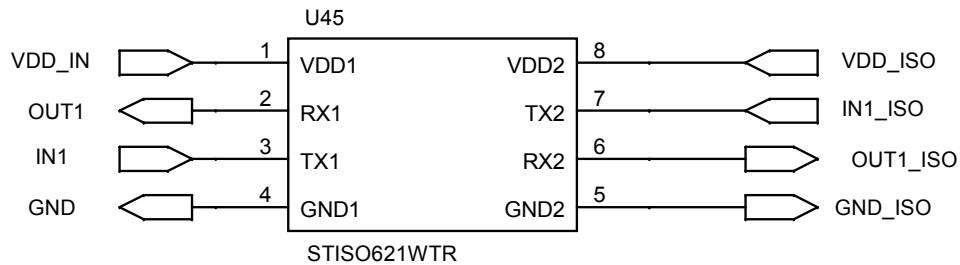

Figure 4. STEVAL-SILKTA01 circuit schematic (4 of 21)

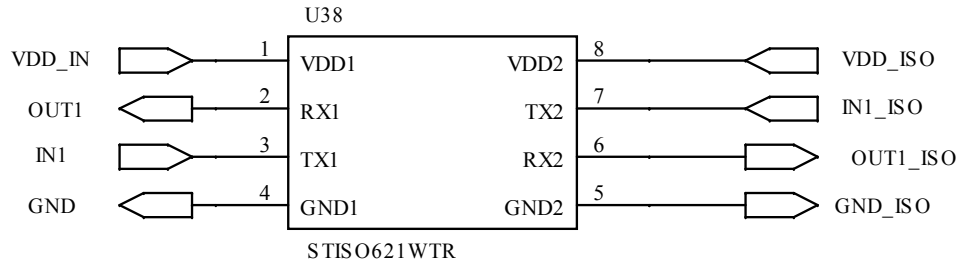

Figure 5. STEVAL-SILKTA01 circuit schematic (5 of 21)

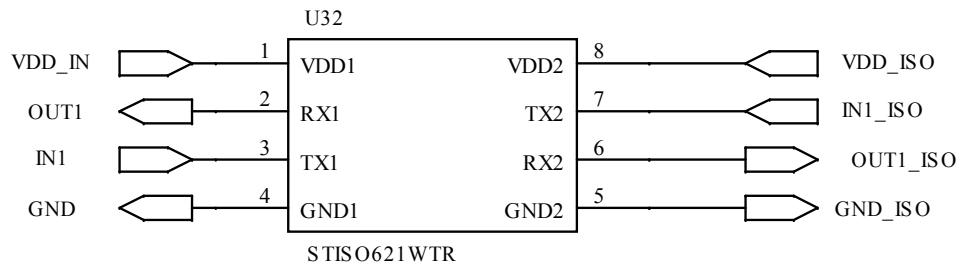

Figure 6. STEVAL-SILKTA01 circuit schematic (6 of 21)

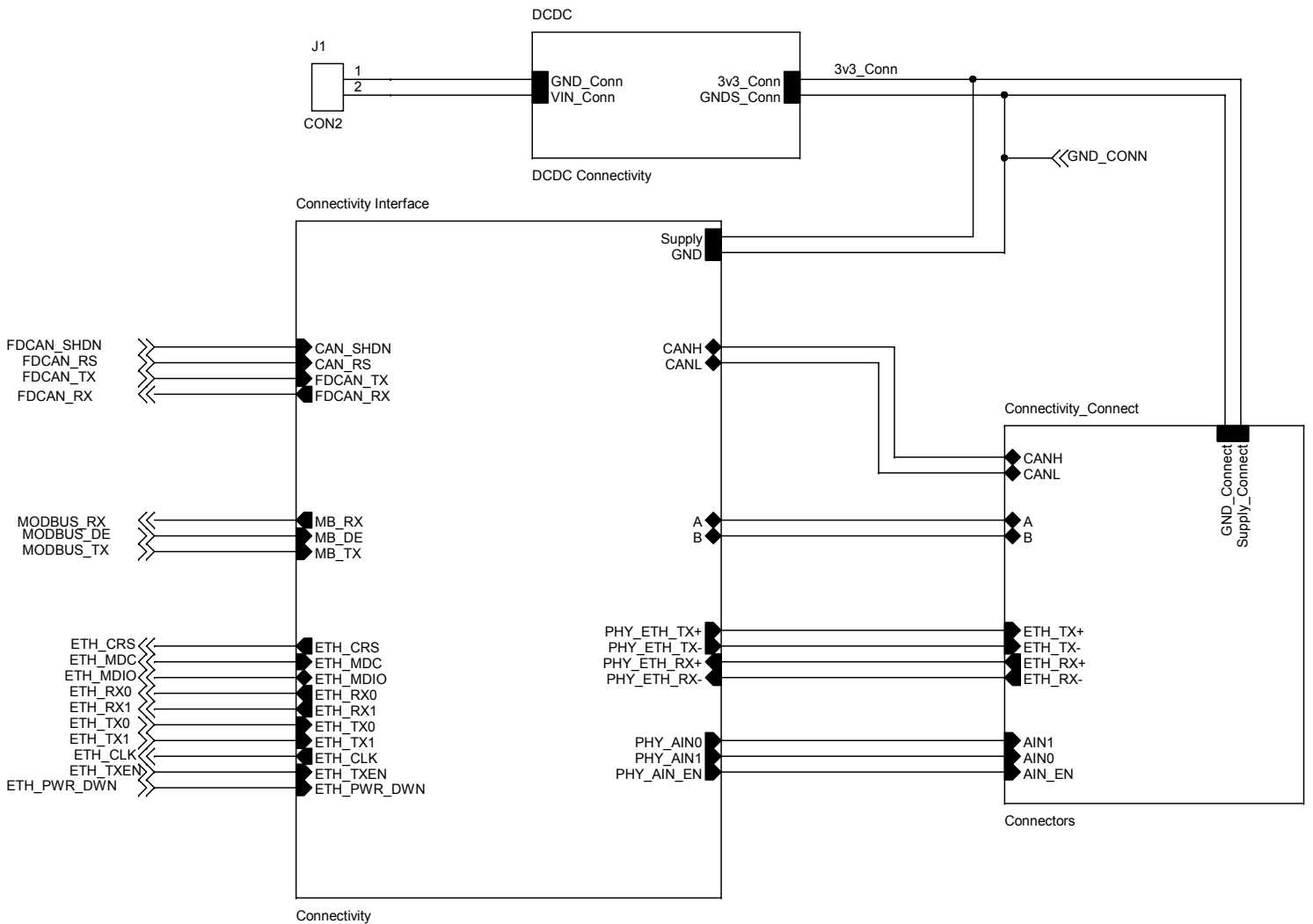

Figure 7. STEVAL-SILKTA01 circuit schematic (7 of 21)

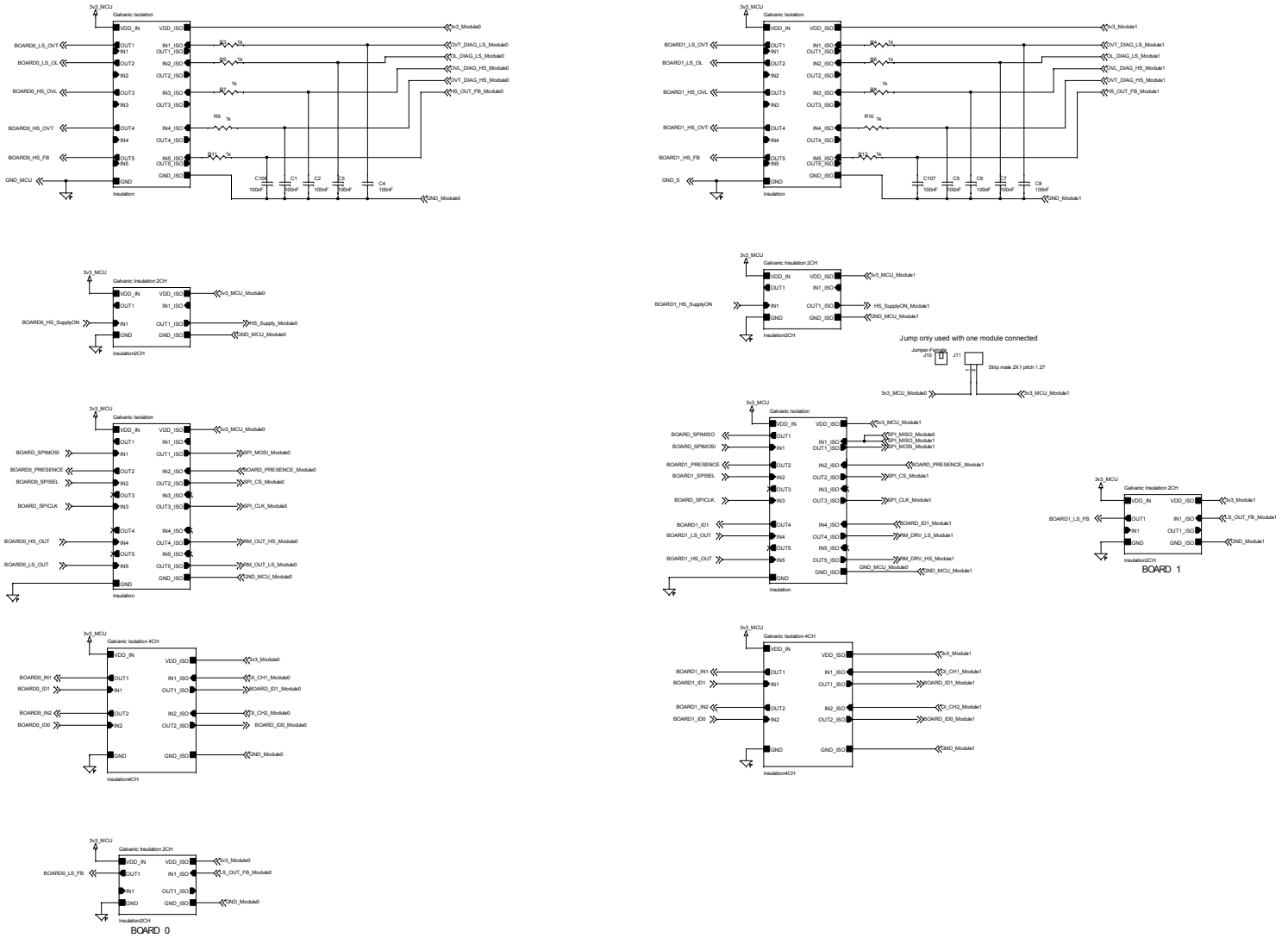

Figure 8. STEVAL-SILKTA01 circuit schematic (8 of 21)

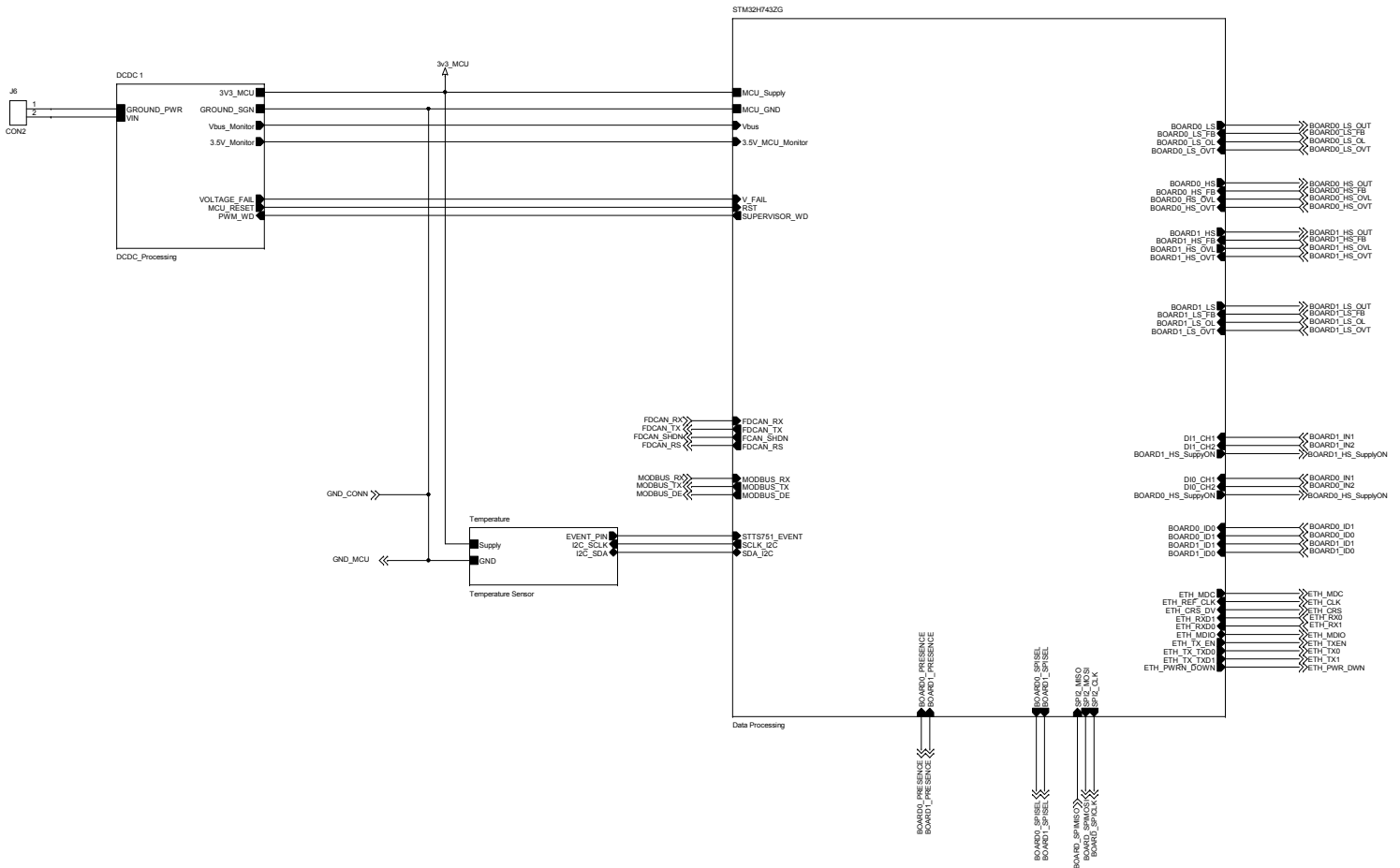

Figure 9. STEVAL-SILKTA01 circuit schematic (9 of 21)



Figure 10. STEVAL-SILKTA01 circuit schematic (10 of 21)

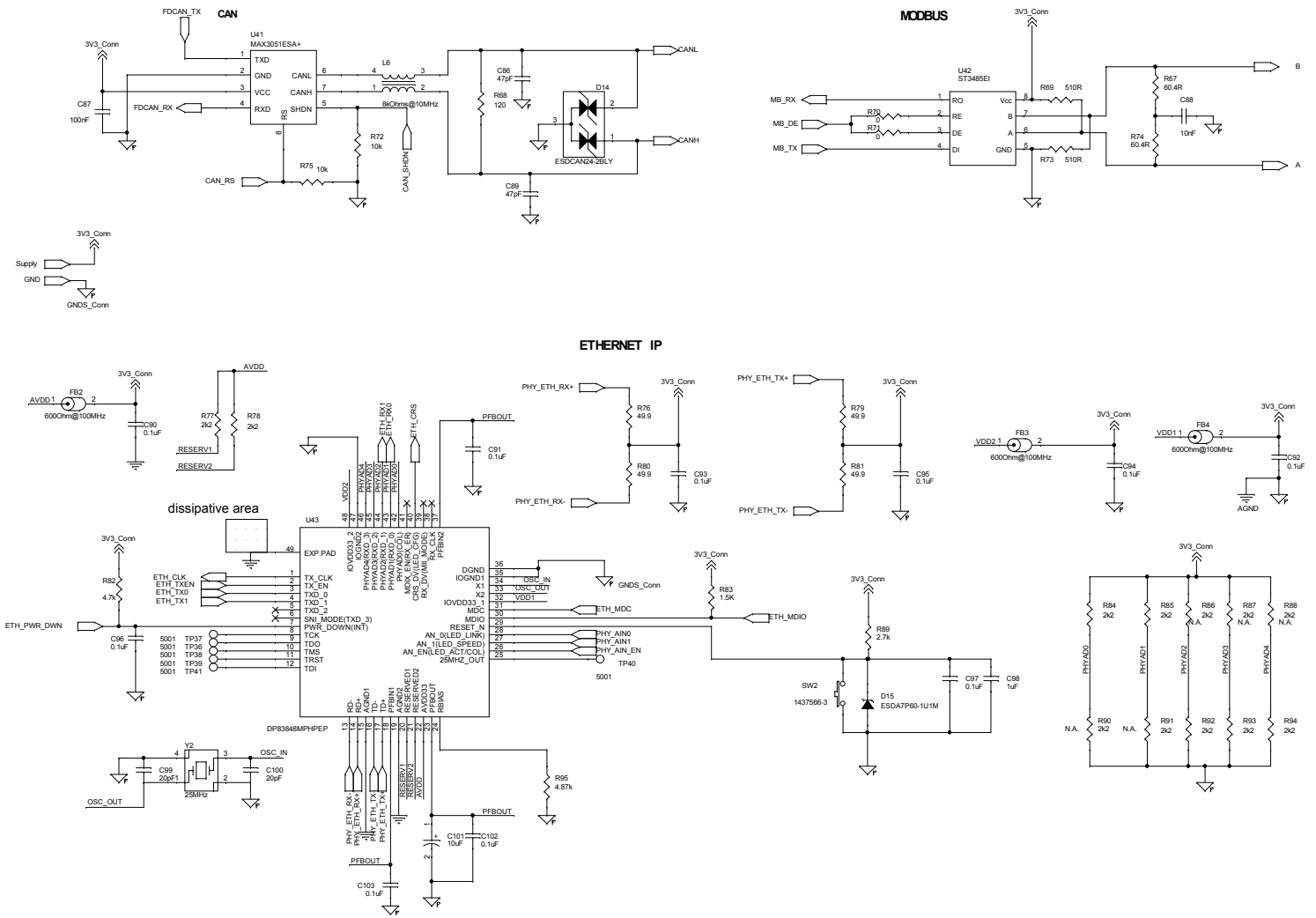

Figure 11. STEVAL-SILKTA01 circuit schematic (11 of 21)

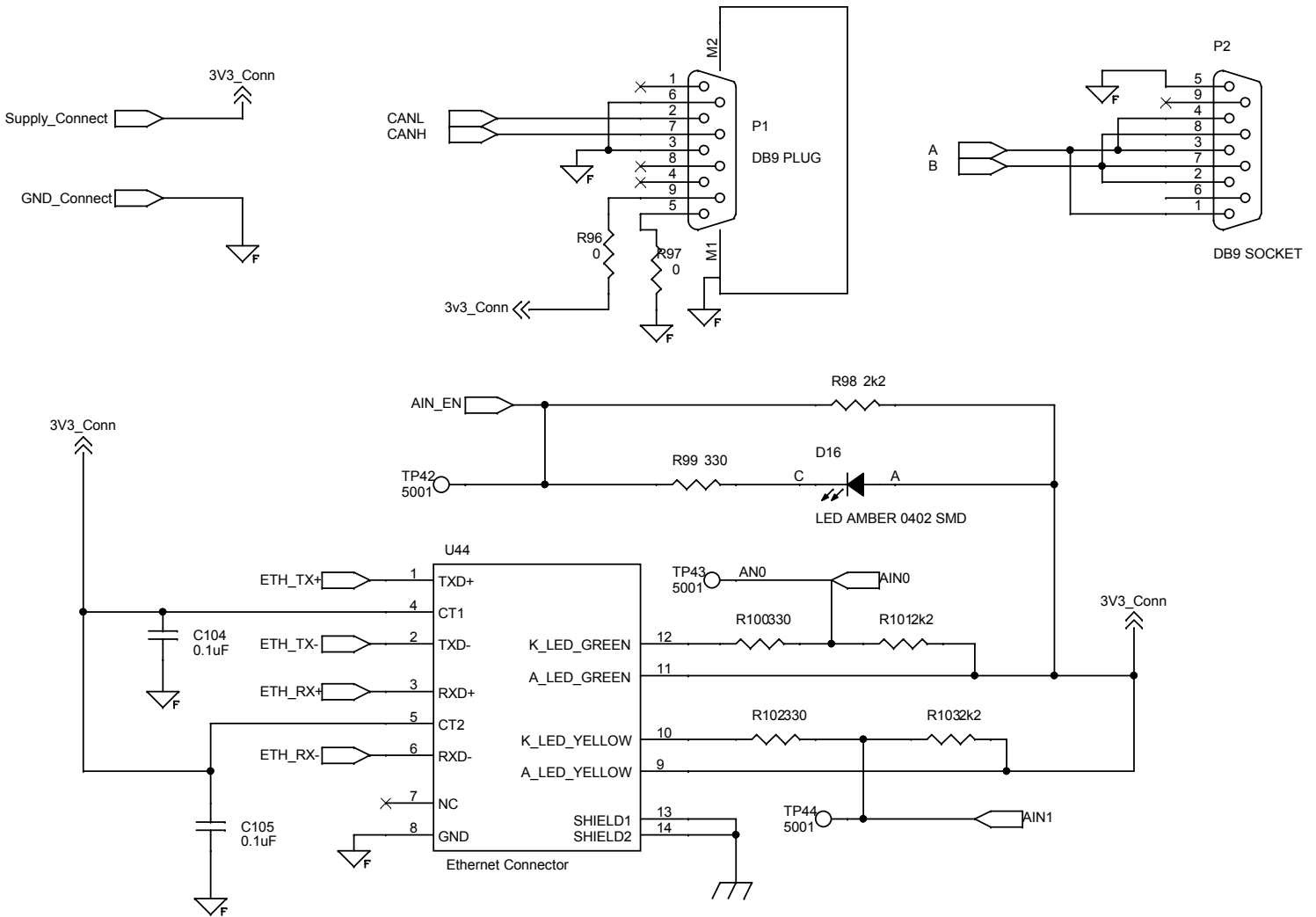

Figure 12. STEVAL-SILKTA01 circuit schematic (12 of 21)

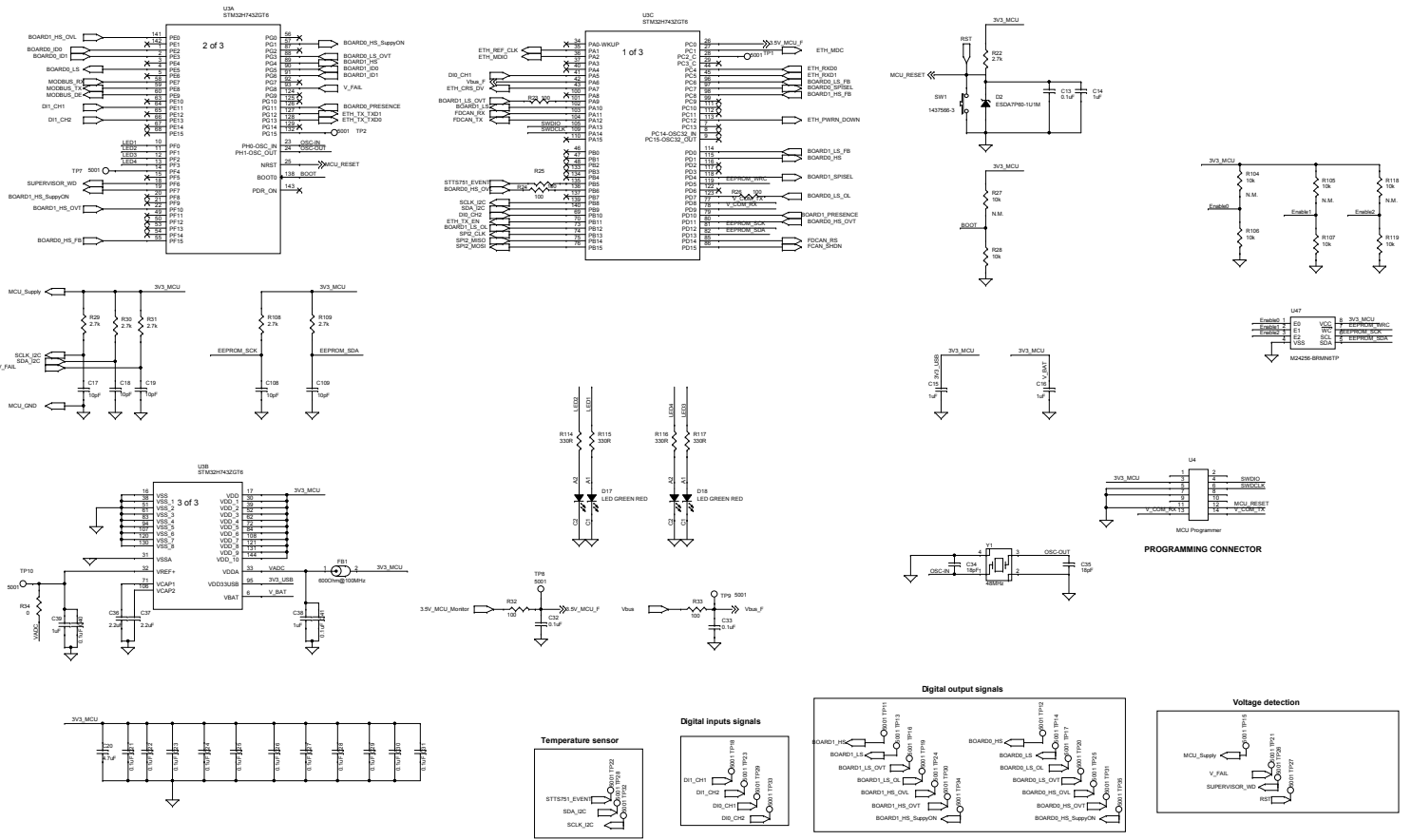
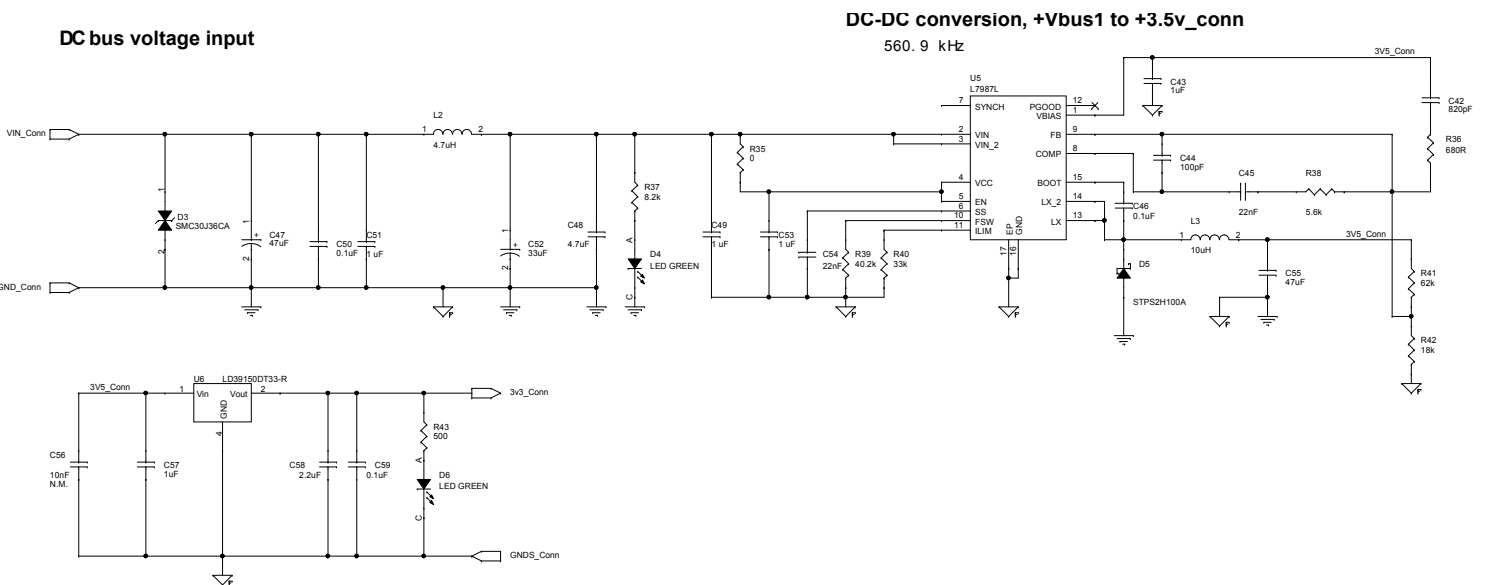

Figure 13. STEVAL-SILKTA01 circuit schematic (13 of 21)



DC bus voltage input

DC-DC conversion, +Vbus1 to +3.5v_conn
560.9 kHz

Figure 14. STEVAL-SILKTA01 circuit schematic (14 of 21)

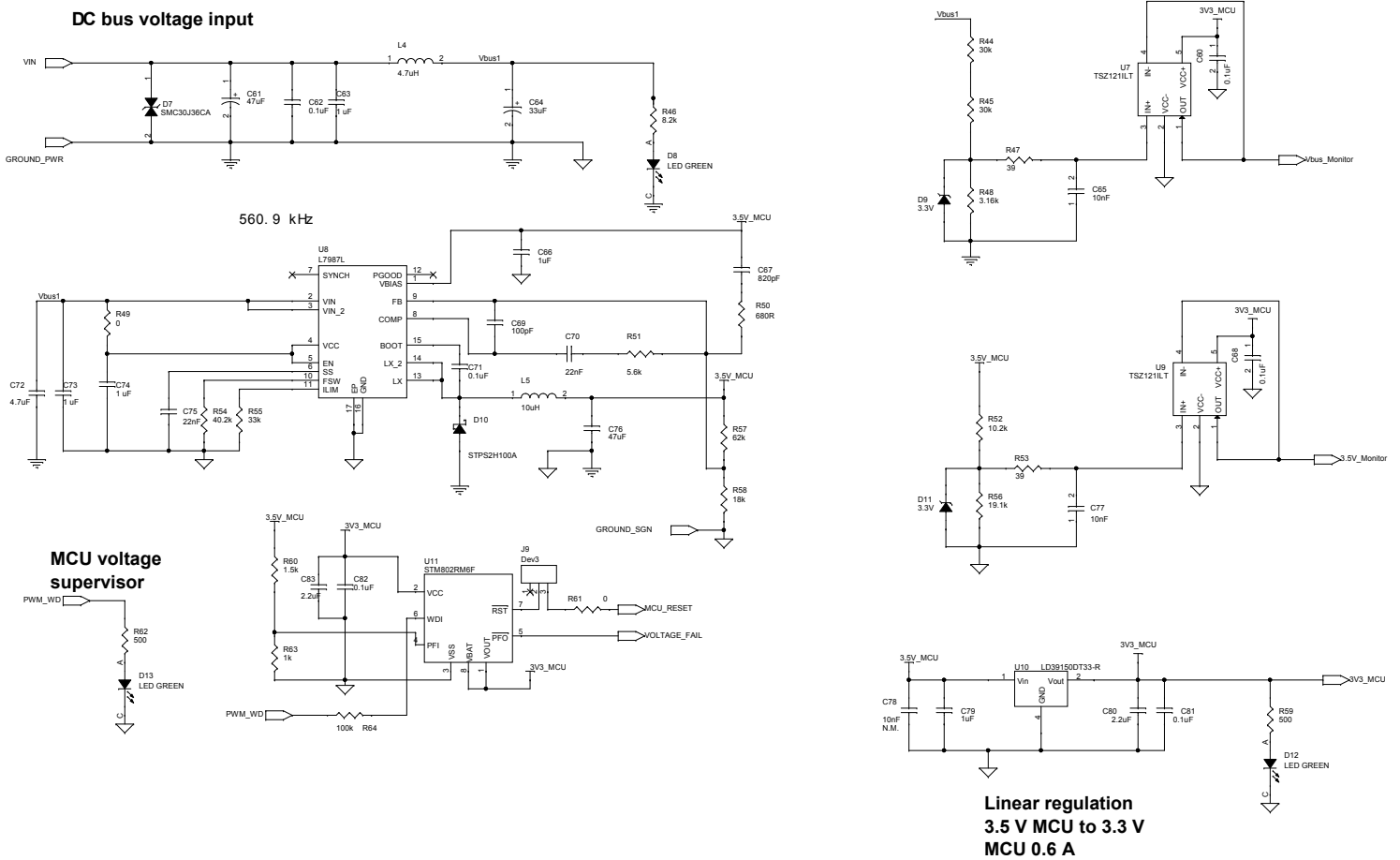

Figure 15. STEVAL-SILKTA01 circuit schematic (15 of 21)

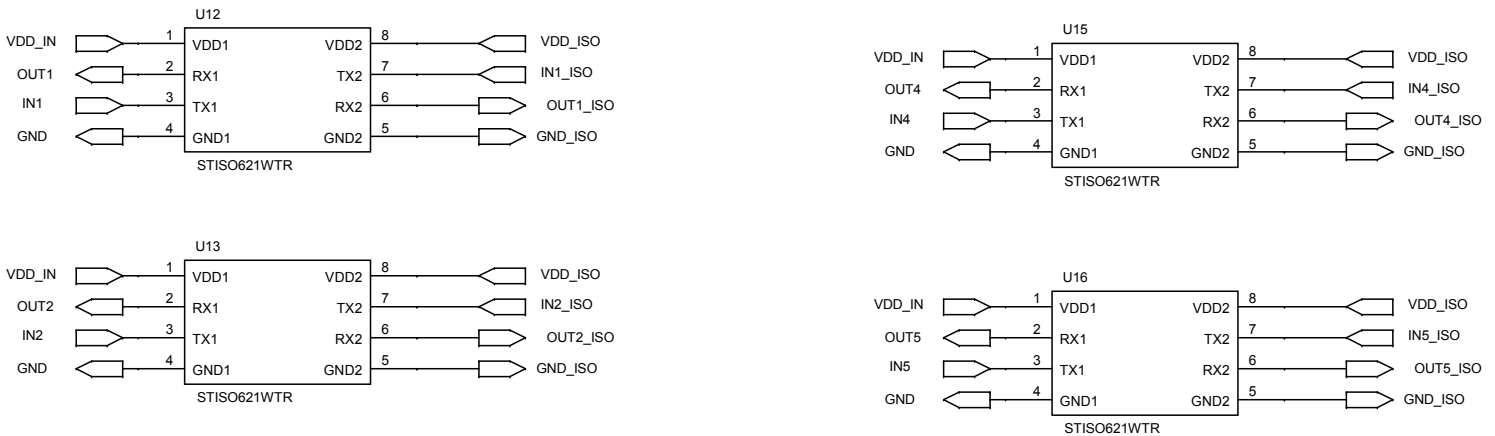

Figure 16. STEVAL-SILKTA01 circuit schematic (16 of 21)

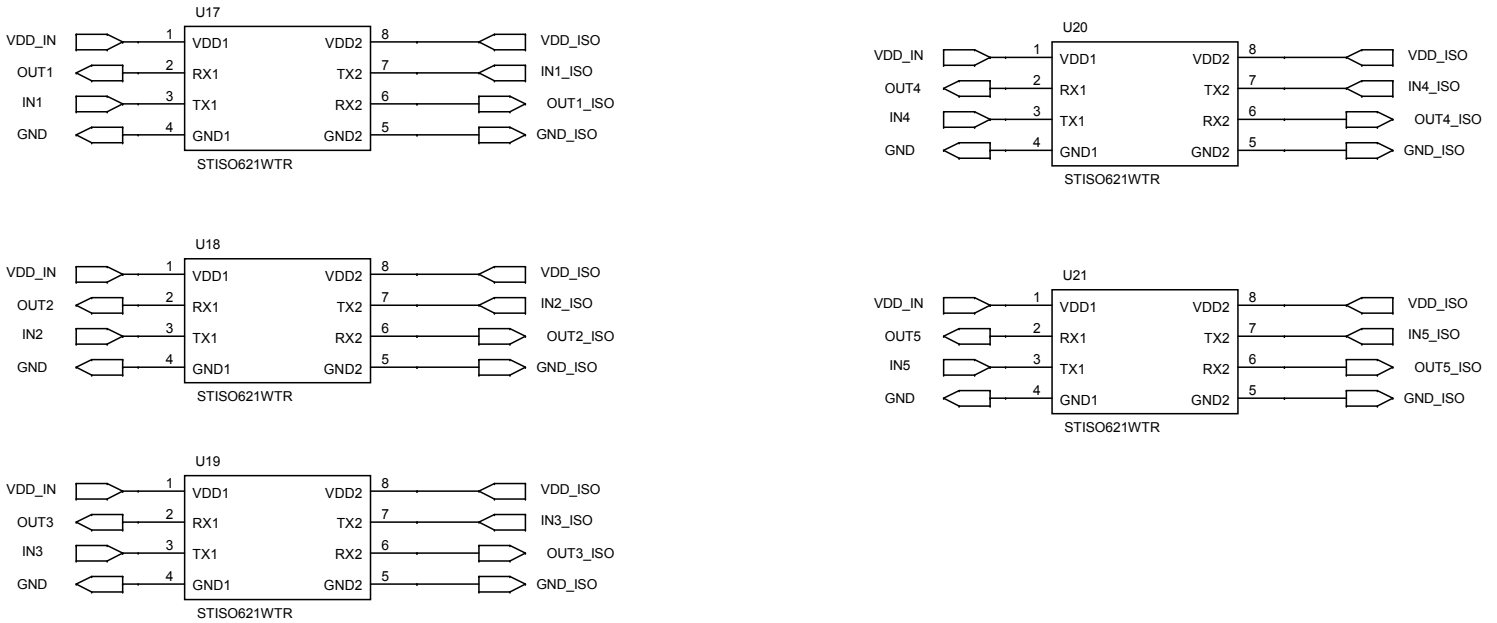

Figure 17. STEVAL-SILKTA01 circuit schematic (17 of 21)

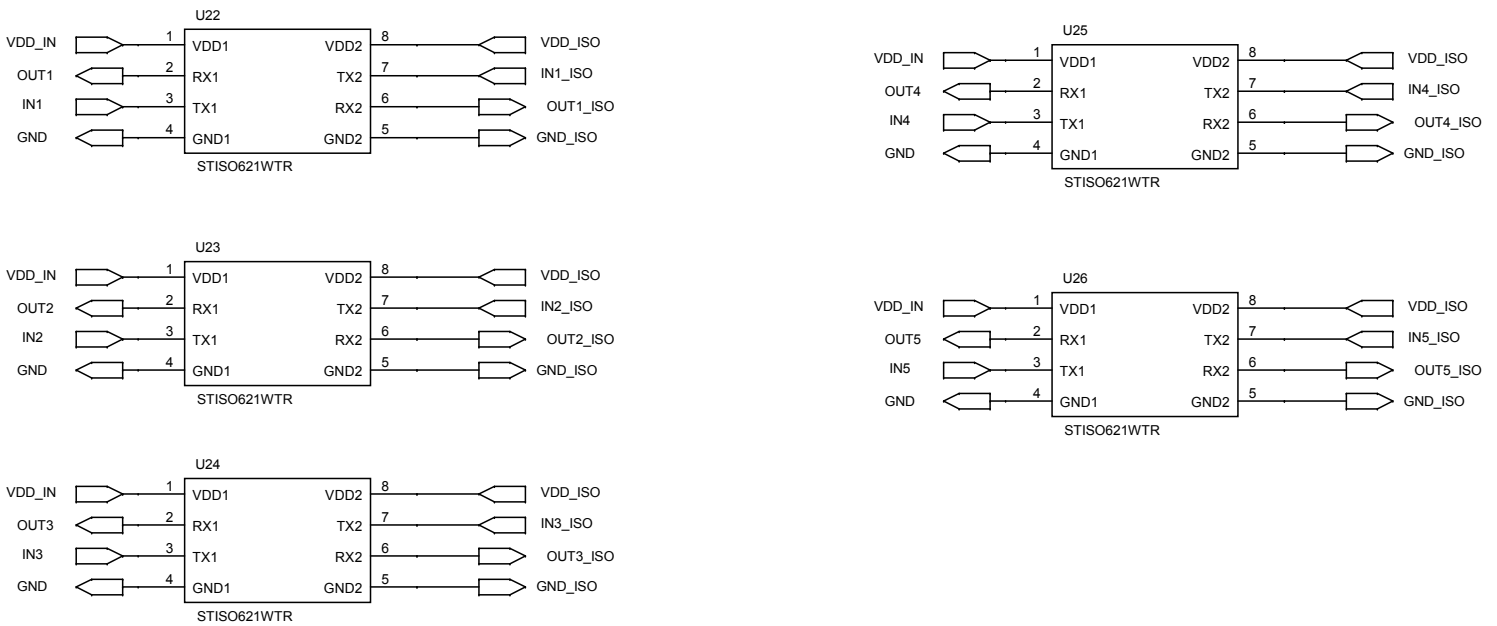

Figure 18. STEVAL-SILKTA01 circuit schematic (18 of 21)

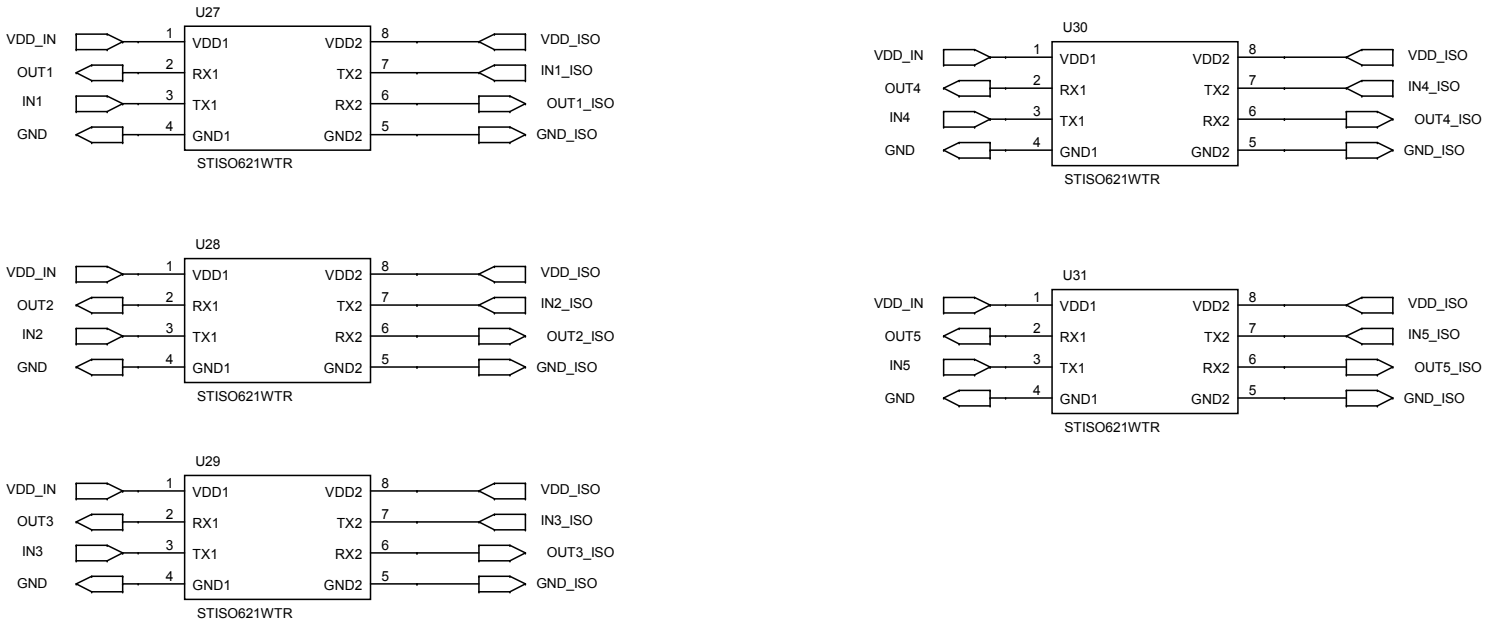

Figure 19. STEVAL-SILKTA01 circuit schematic (19 of 21)

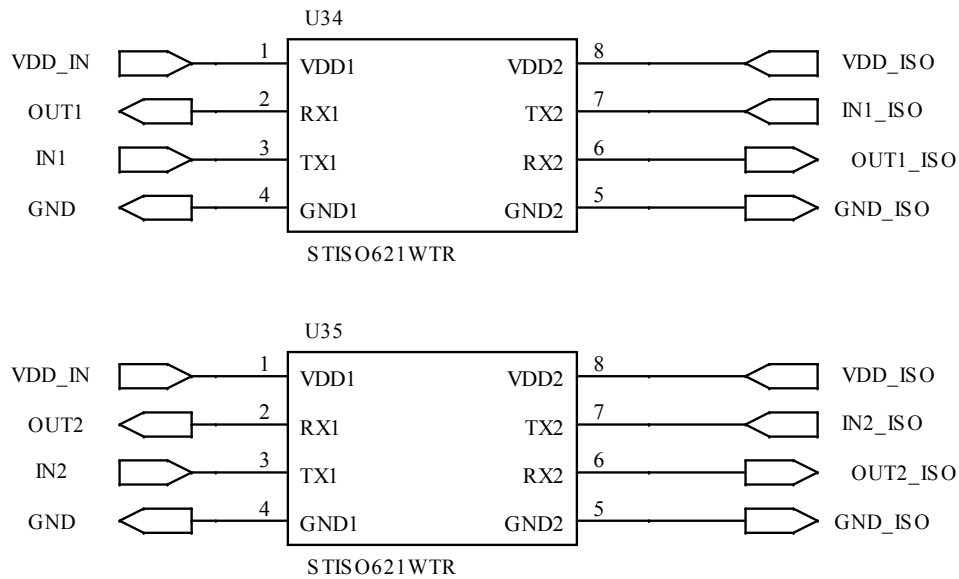

Figure 20. STEVAL-SILKTA01 circuit schematic (20 of 21)

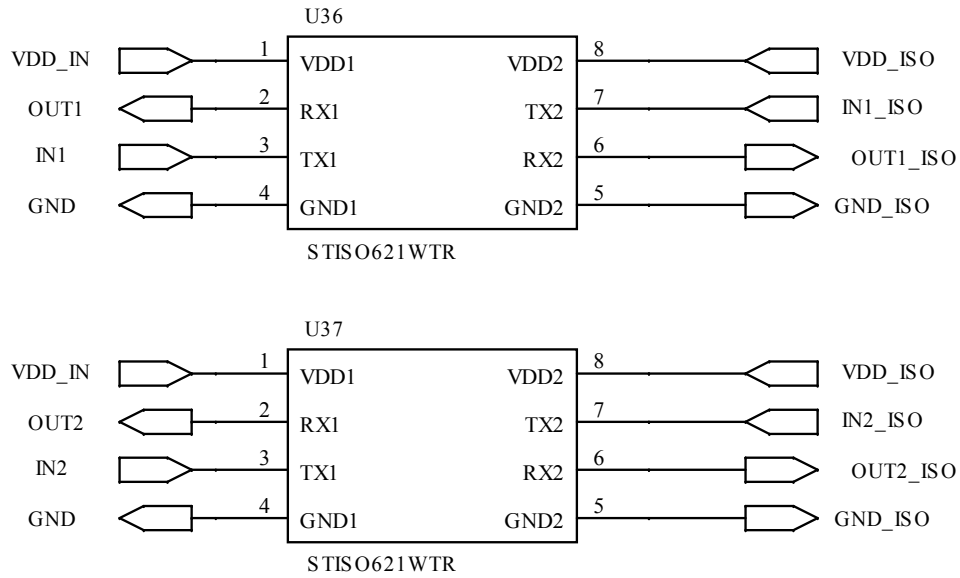

Figure 21. STEVAL-SILKTA01 circuit schematic (21 of 21)

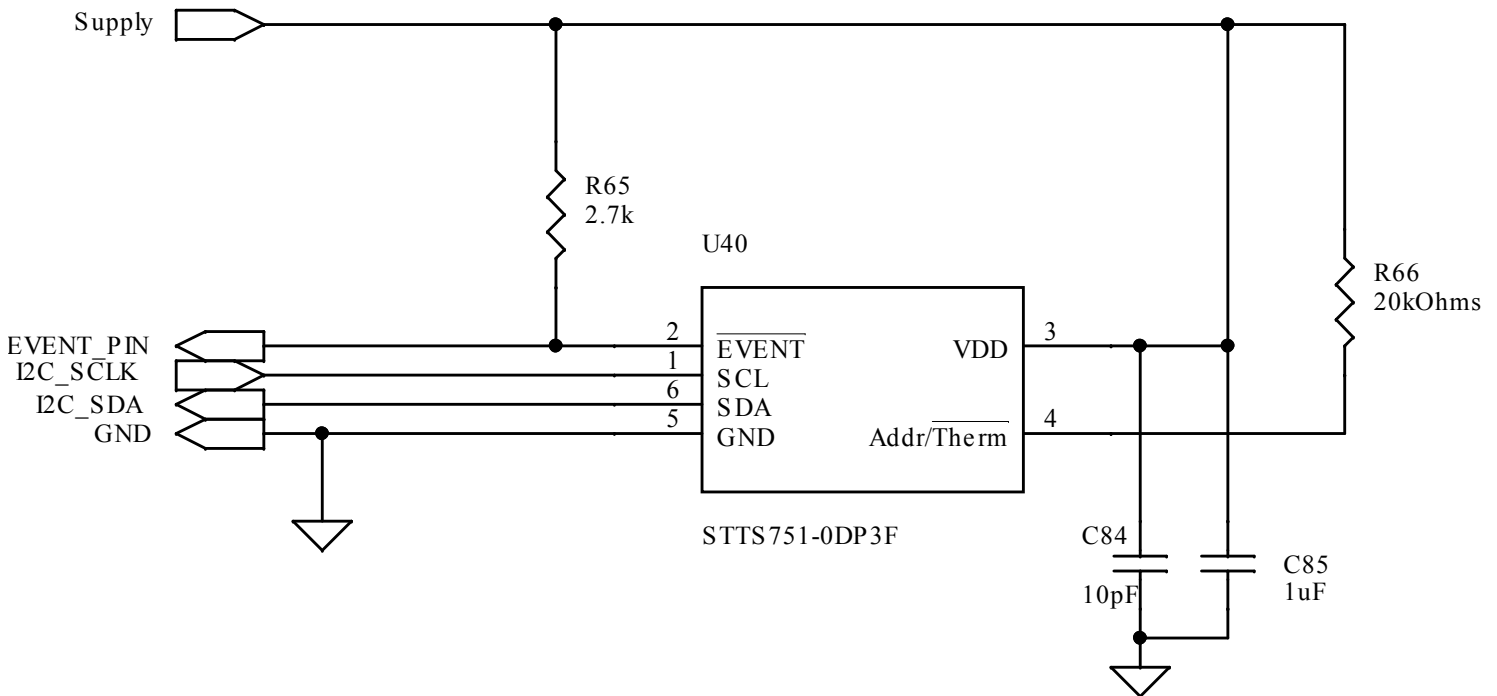

Figure 22. STEVAL-SILKTB01 circuit schematic (1 of 12)

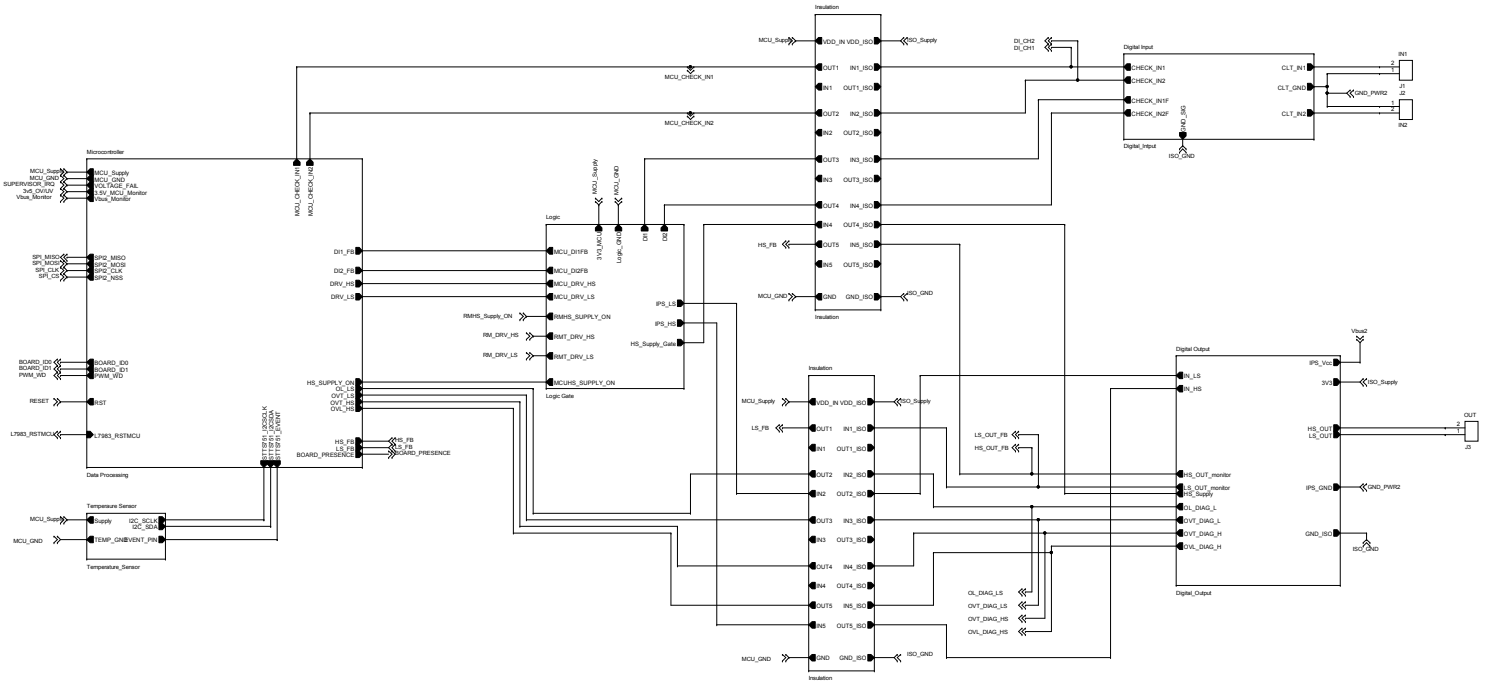
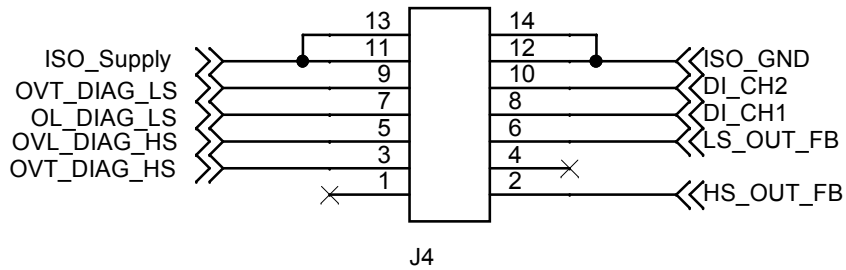
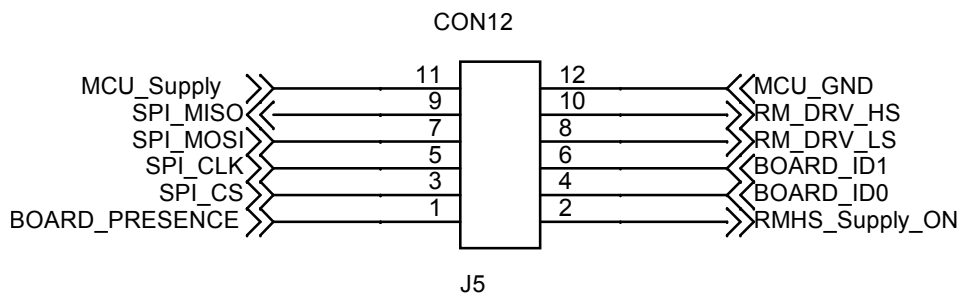

Figure 23. STEVAL-SILKTB01 circuit schematic (2 of 12)

CON 7X2 pitch 2.54 90G



J4



J5

Figure 24. STEVAL-SILKTB01 circuit schematic (3 of 12)

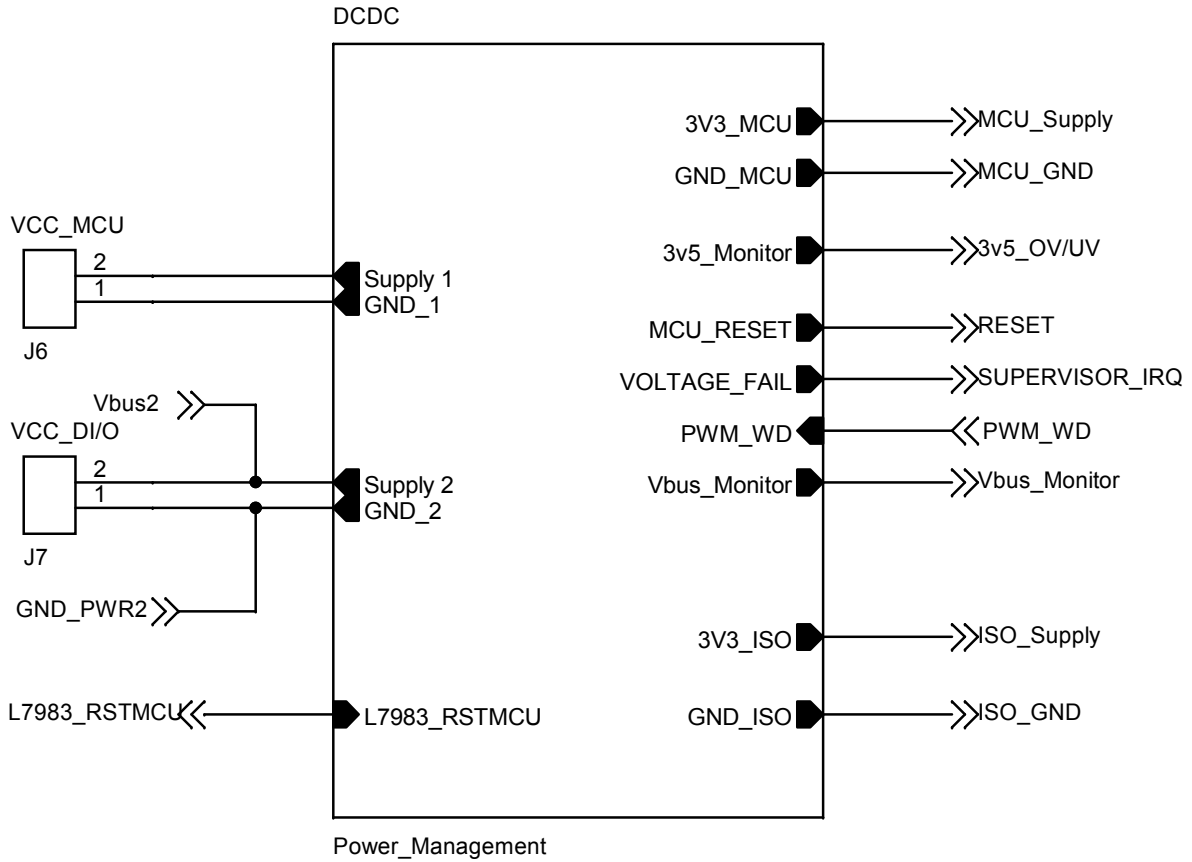

Figure 25. STEVAL-SILKTB01 circuit schematic (4 of 12)

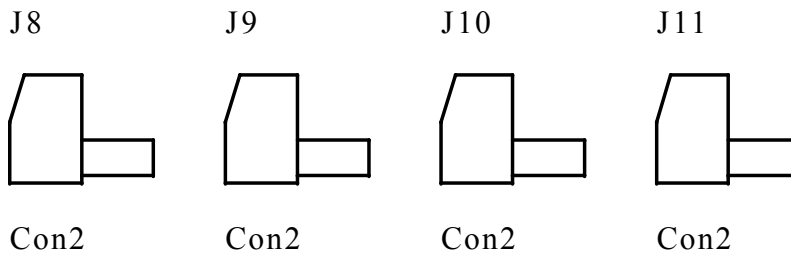

Figure 26. STEVAL-SILKTB01 circuit schematic (5 of 12)

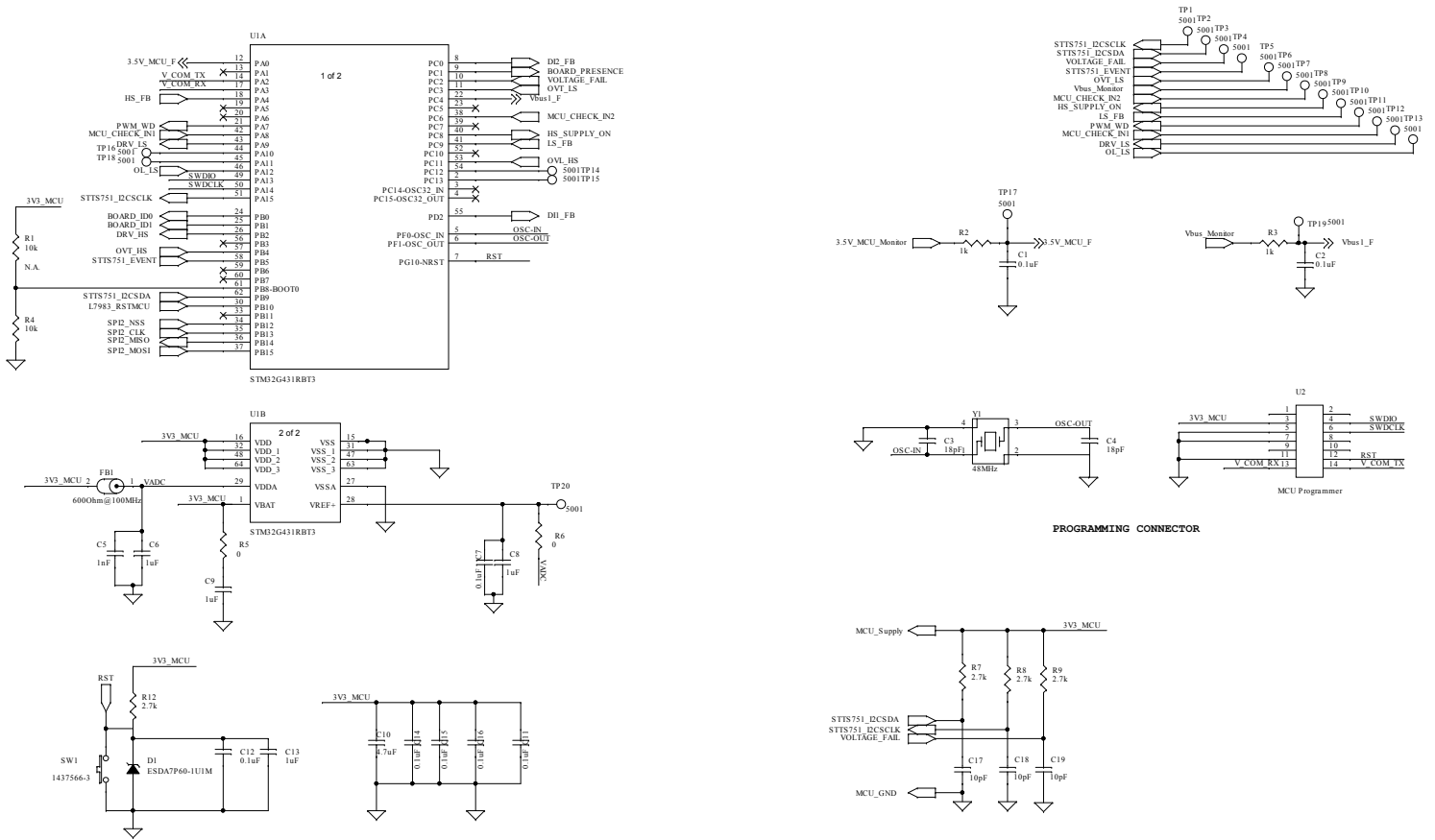

Figure 27. STEVAL-SILKTB01 circuit schematic (6 of 12)

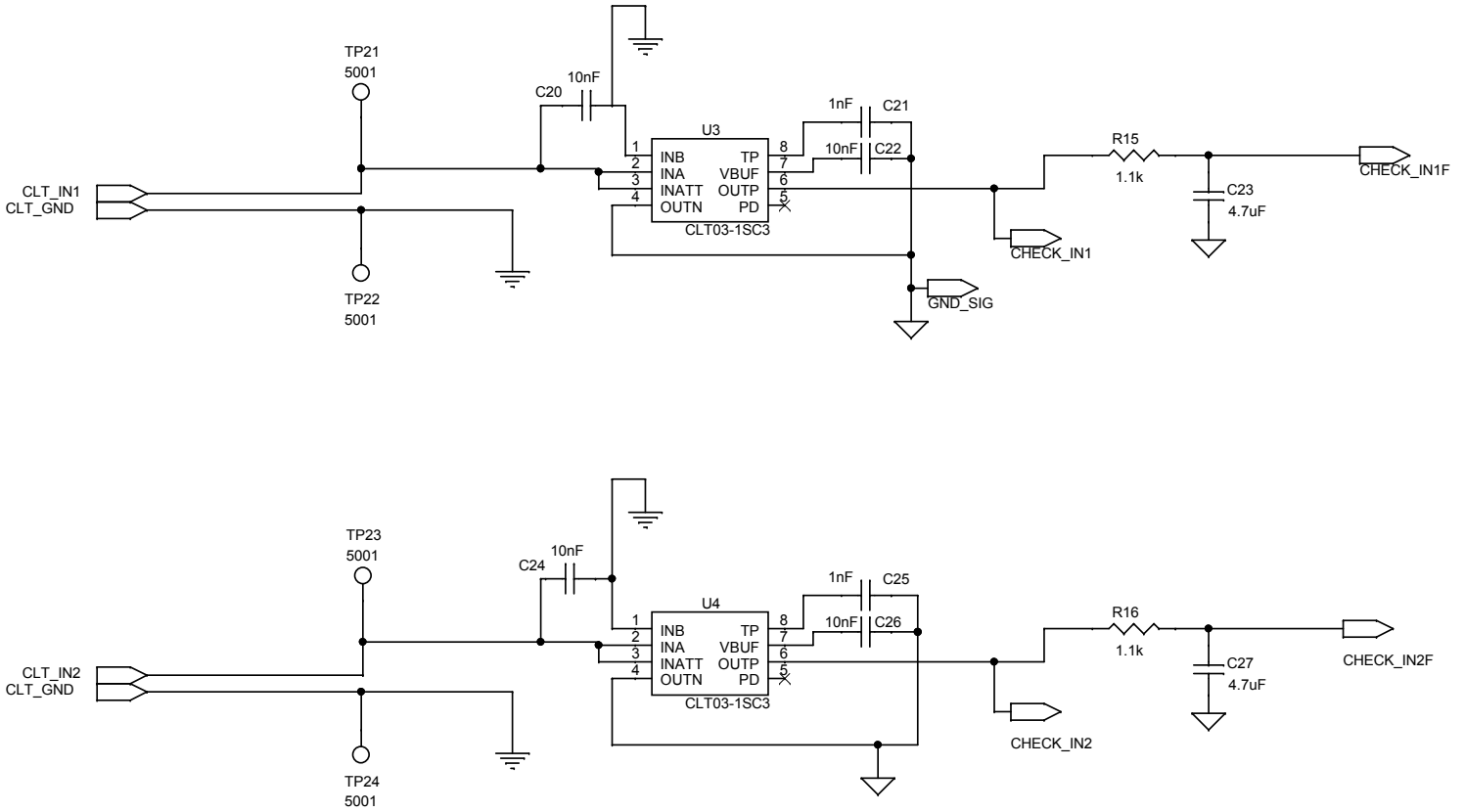

Figure 28. STEVAL-SILKTB01 circuit schematic (7 of 12)

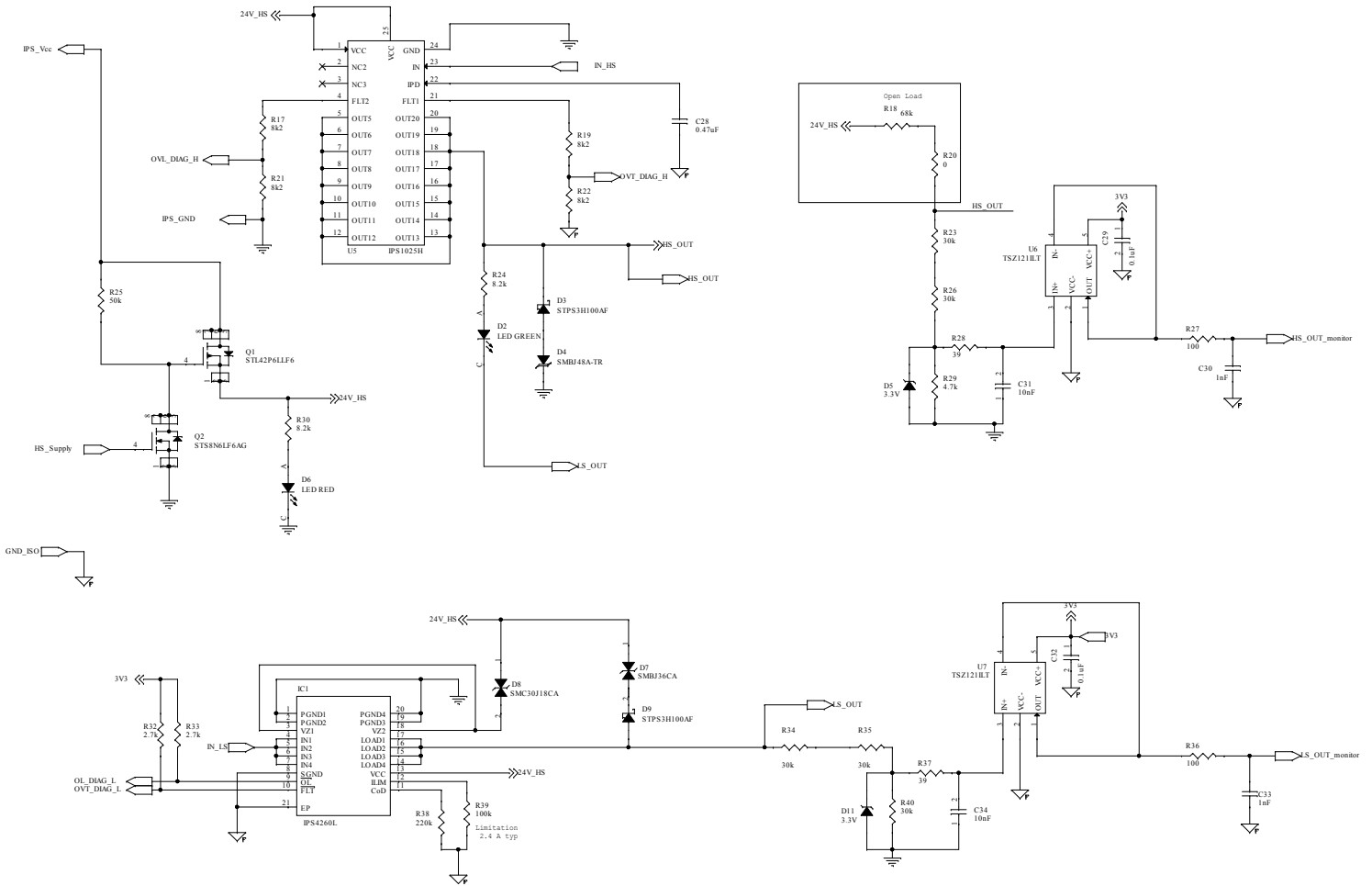

Figure 29. STEVAL-SILKTB01 circuit schematic (8 of 12)

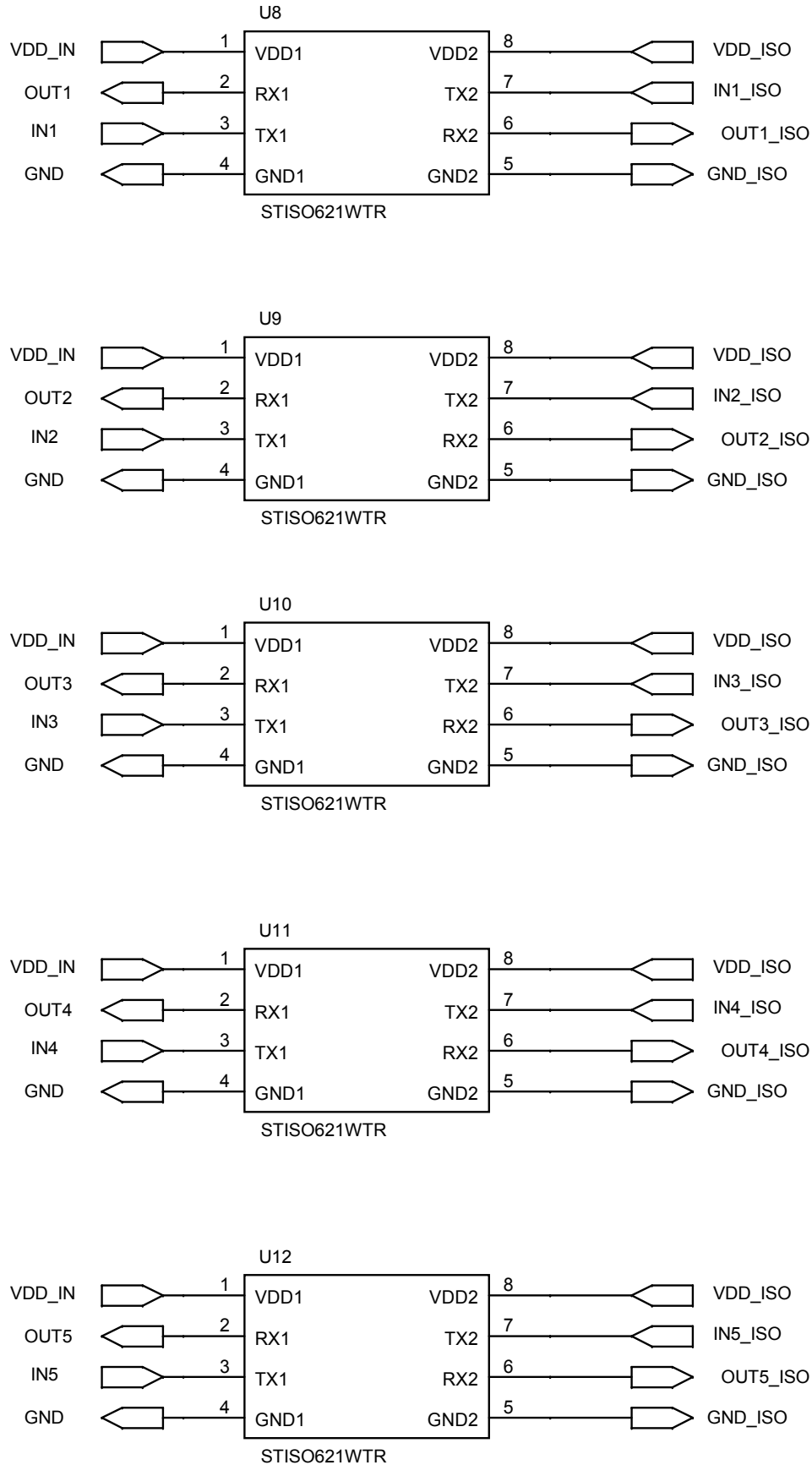

Figure 30. STEVAL-SILKTB01 circuit schematic (9 of 12)

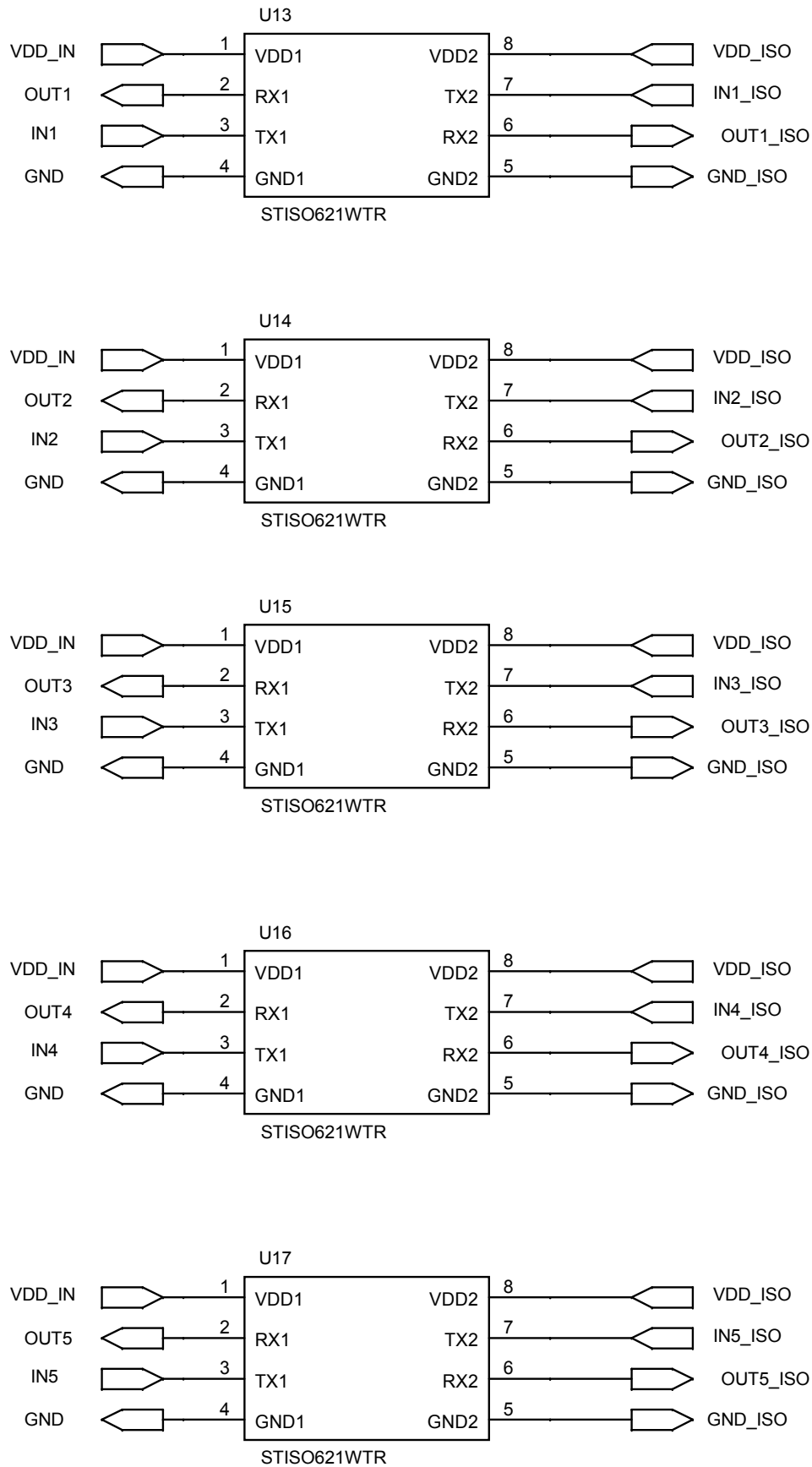

Figure 31. STEVAL-SILKTB01 circuit schematic (10 of 12)

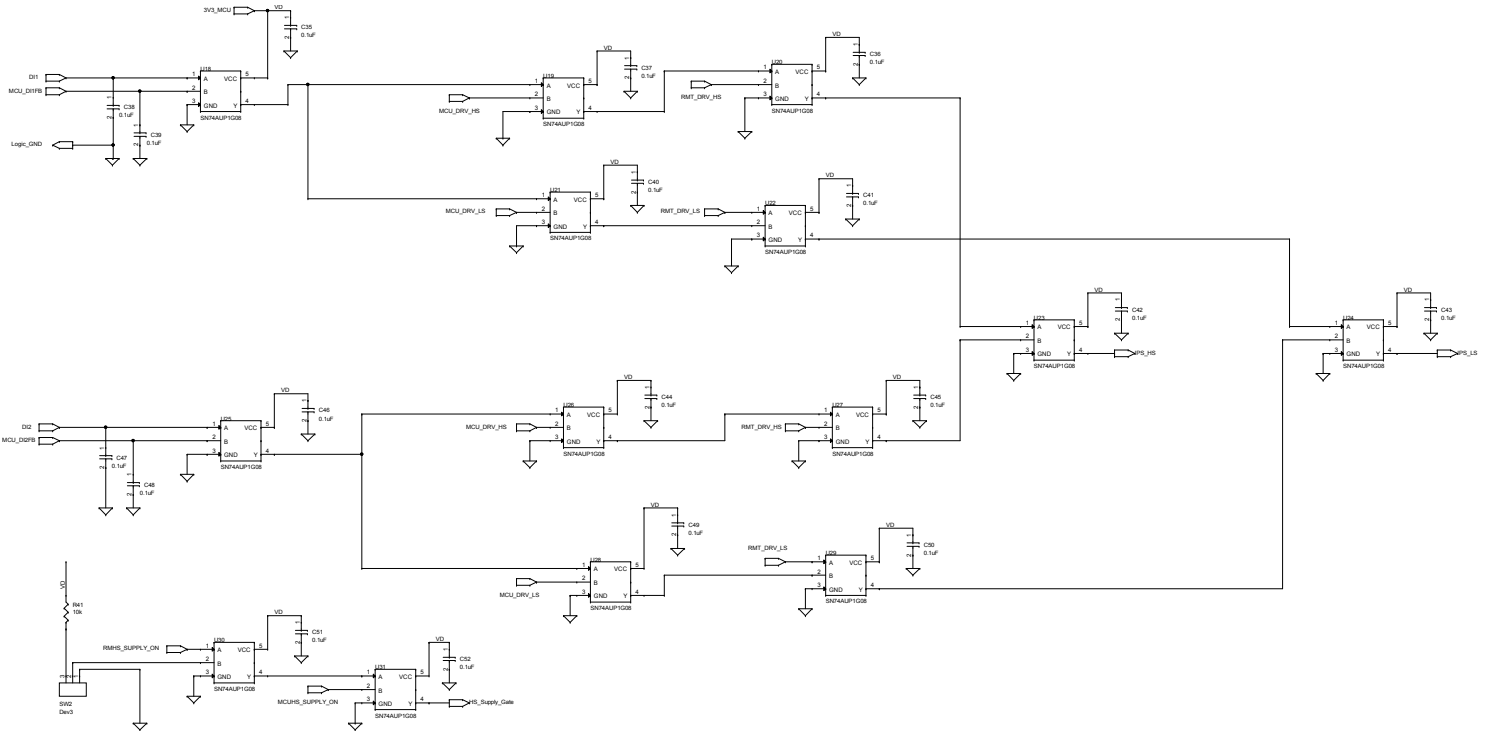

Figure 32. STEVAL-SILKTB01 circuit schematic (11 of 12)

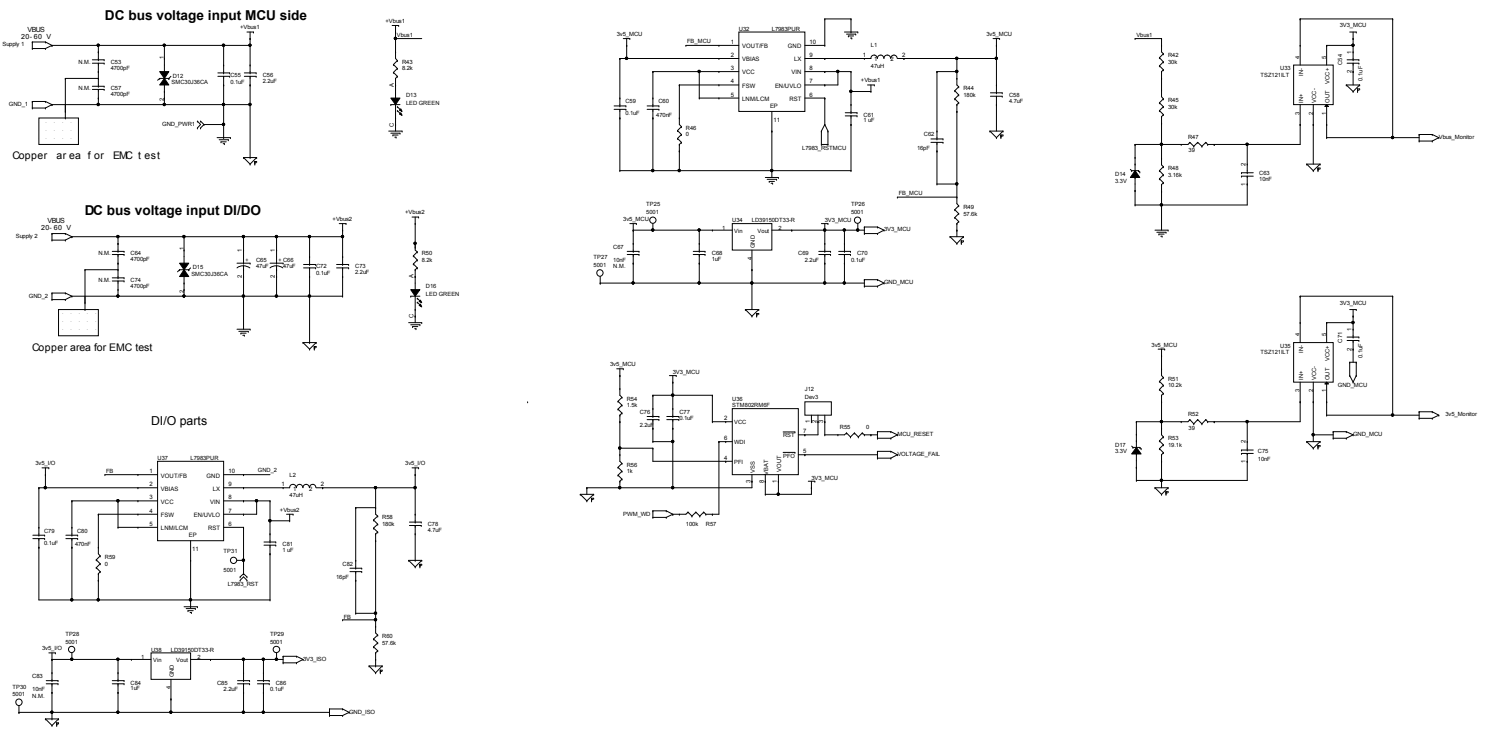
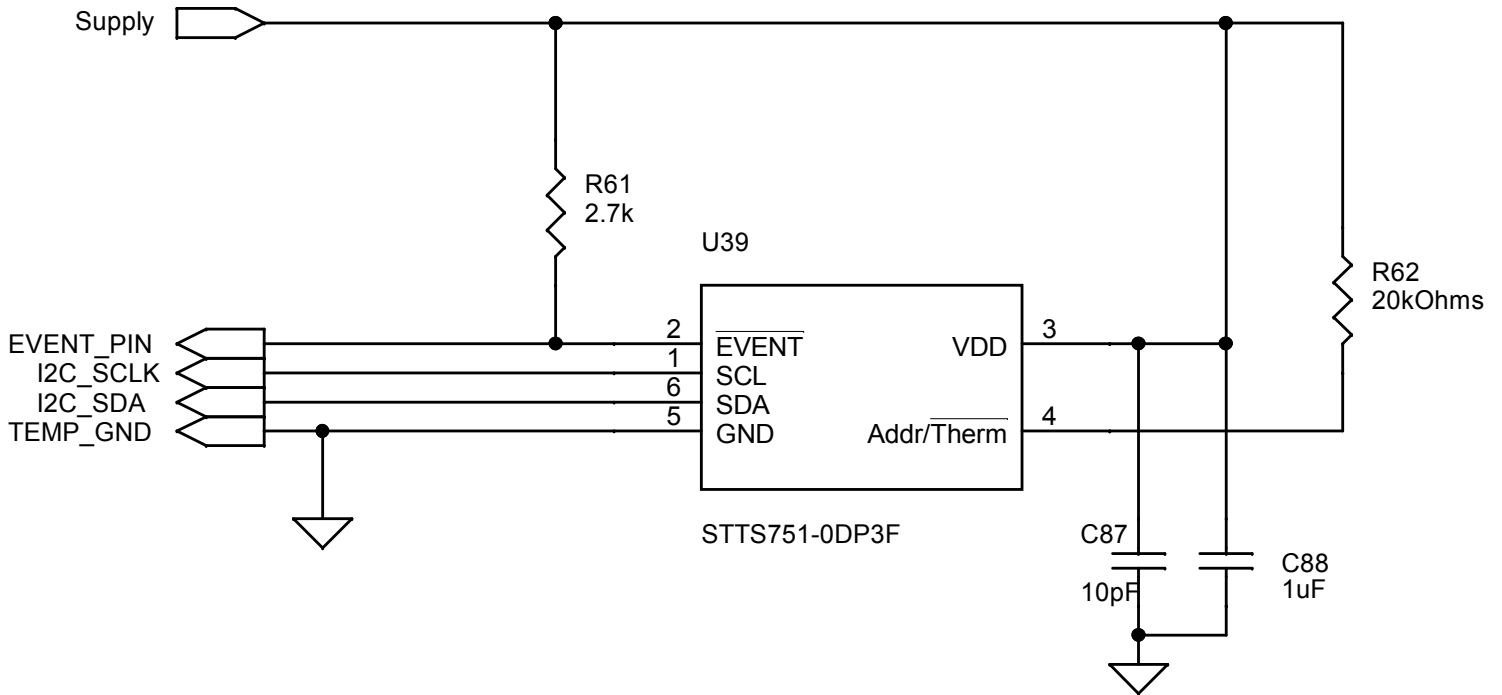

Figure 33. STEVAL-SILKTB01 circuit schematic (12 of 12)



IMPORTANT NOTICE – READ CAREFULLY

STMicroelectronics NV and its subsidiaries (“ST”) reserve the right to make changes, corrections, enhancements, modifications, and improvements to ST products and/or to this document at any time without notice. Purchasers should obtain the latest relevant information on ST products before placing orders. ST products are sold pursuant to ST’s terms and conditions of sale in place at the time of order acknowledgment.

Purchasers are solely responsible for the choice, selection, and use of ST products and ST assumes no liability for application assistance or the design of purchasers’ products.

No license, express or implied, to any intellectual property right is granted by ST herein.

Resale of ST products with provisions different from the information set forth herein shall void any warranty granted by ST for such product.

ST and the ST logo are trademarks of ST. For additional information about ST trademarks, refer to www.st.com/trademarks. All other product or service names are the property of their respective owners.

Information in this document supersedes and replaces information previously supplied in any prior versions of this document.

© 2024 STMicroelectronics – All rights reserved