



---

**Designing robust protection of automotive power rails against  
overvoltage and reverse polarity battery hazards**

---

## **Introduction**

The automotive environment is the source of many electrical hazards. These hazards, such as electromagnetic interference, electrostatic discharges and other electrical disturbances, are generated by various automotive sub-systems like ignition, relay contacts, alternator, injectors, and other accessories.

These hazards can occur directly in the wiring harness in case of conducted hazards, or be applied indirectly to electronic modules by radiation. These generated hazards can impact the electronics in two ways - either on the data lines or on the power rail wires, depending on the environment.

These disturbances found in the automotive environment are described in several standards like ISO 7637, ISO 16750, ISO 10605, and SAE J-1113 among others.

This document describes design considerations for particular protection solutions against overvoltage and reverse polarity battery hazards as well as design considerations for a combined solution.

# 1 Surge definition standards

Figure 1 and Figure 2 show simplified forms of the main surges that can affect automotive electronic parts.

Figure 1. ISO 7637 and ISO 16750 main surges on automotive power rail

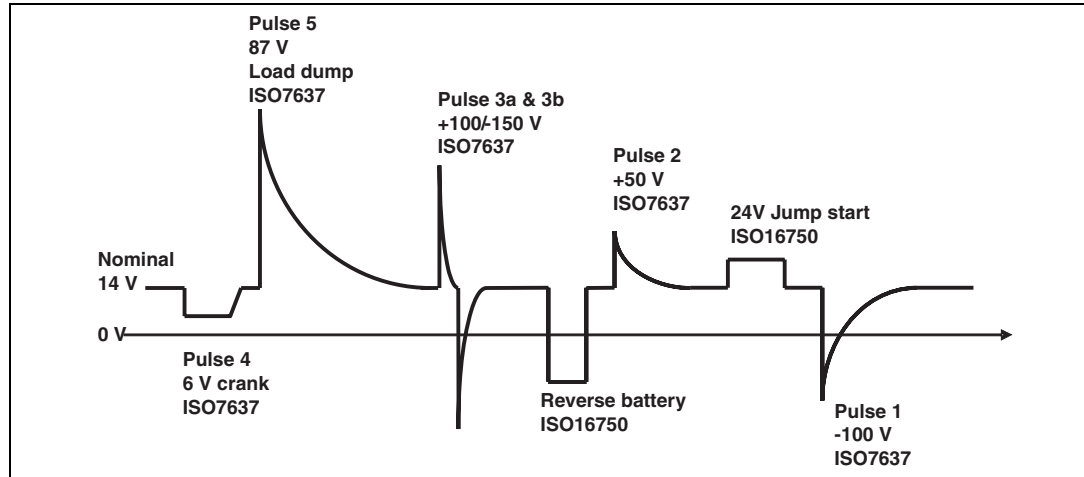
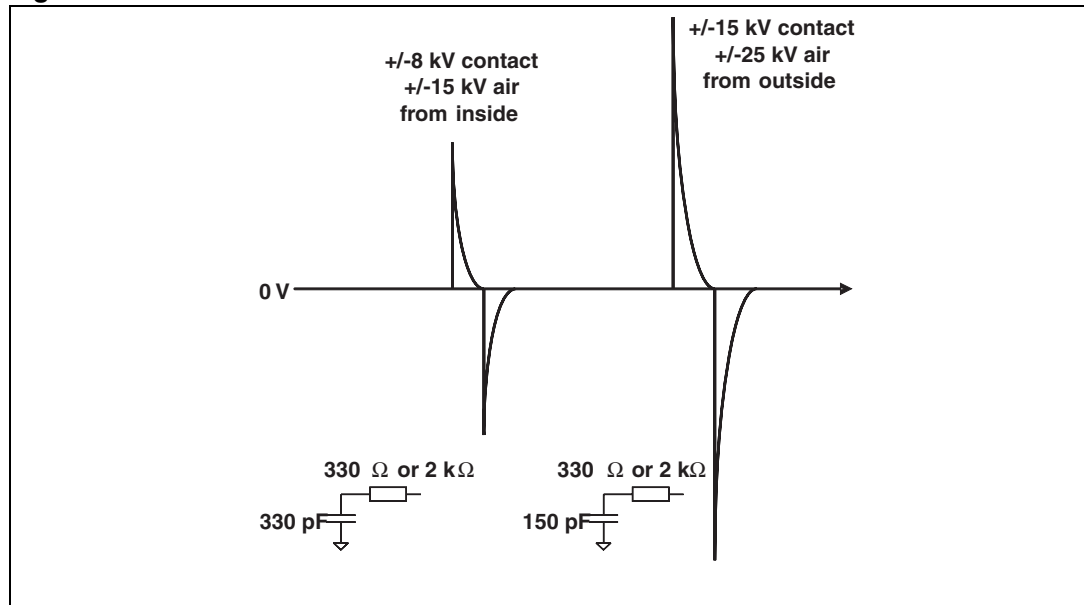

Figure 2. ISO 10605 vehicle test levels



To prevent the onboard electronic modules being disturbed, or even damaged, designers have to consider protection devices each time they develop a new module. Their choice can range from a simple clamping topology like using varistors or Transils™ to more sophisticated protection topologies using several discrete devices or ICs (integrated circuits).

TM: Transil is a trademark of STMicroelectronics

Due to cost considerations clamping device solutions are frequently used.

These clamping solutions generally use varistors or Transils. *Figure 3* shows the device symbols.

**Figure 3. Clamping device symbols**

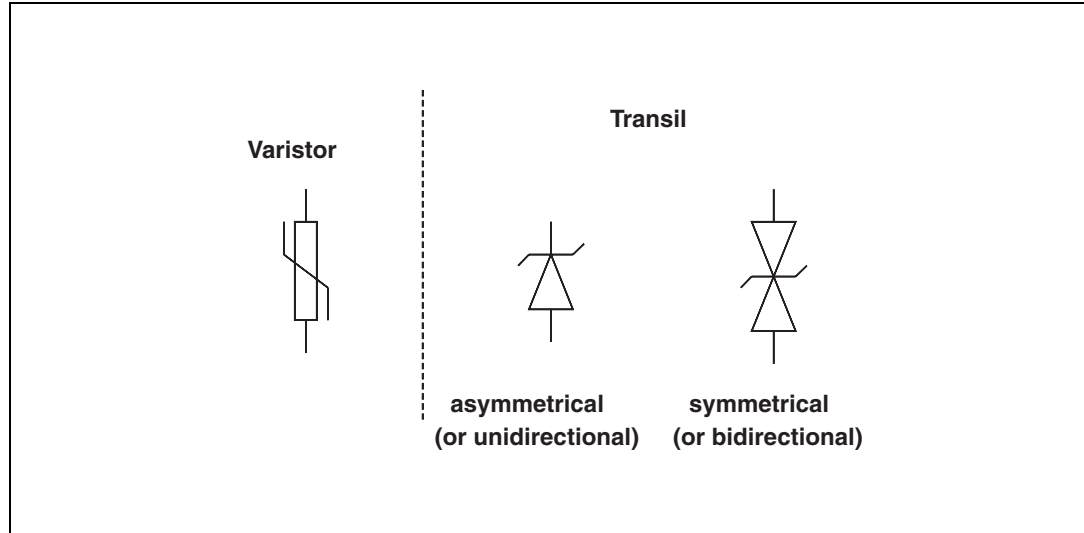

Varistors are always symmetrical clamping devices whereas Transils can be either symmetrical or asymmetrical.

*Figure 4* shows typical static behavior of such devices.

**Figure 4. V/I curves for varistors and Transils**

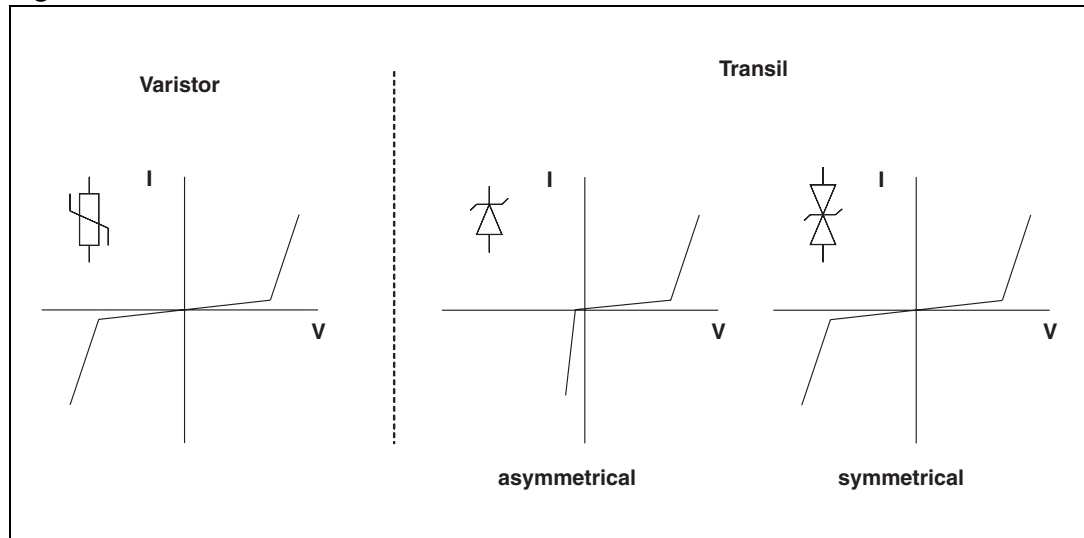

The traces given in *Figure 4* show the static behavior of each device for current versus voltage applied between terminals. We can see that the behavior is symmetrical for varistor device whereas it can be either symmetrical or asymmetrical for Transil devices. This difference is due simply to the different internal physical structure of varistors and Transils (metal oxide structure versus silicon structure).

Figure 5 and Figure 6 show examples of dynamic behavior using either a Transil or a varistor

**Figure 5. Example of electronic module protection with asymmetrical Transil™ when positive or negative surge occur**

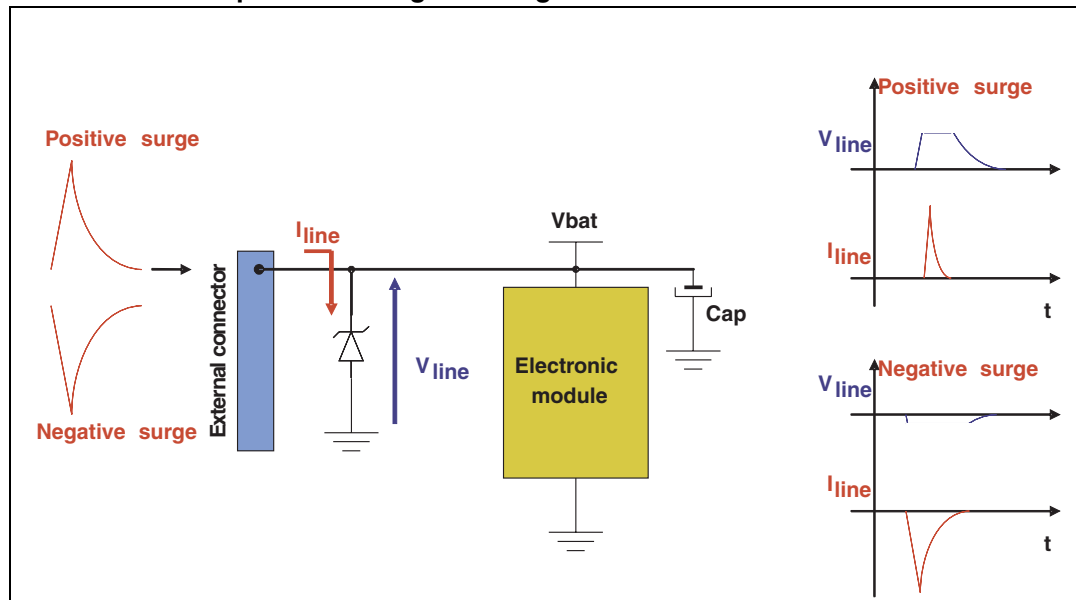

**Figure 6. Example of electronic module protection with a varistor when positive or negative surge occur**

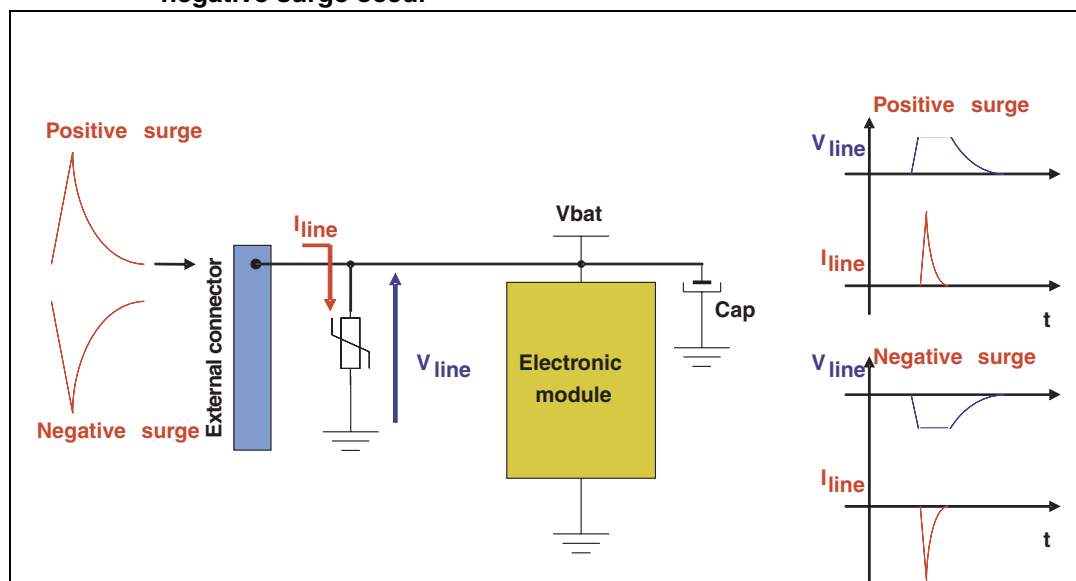

In some cases using asymmetrical Transil may be preferable compared to varistor.

For instance, as shown in Figure 7, there are some electronic modules that can only support electrical voltage supply varying from +40 V to -3 V. So the use of asymmetrical Transil helps to limit negative electrical overstress to a safe level for the electronics.

**Figure 7. Example of protection when the electronic module can withstand a voltage ranging from -3 V to +40 V**

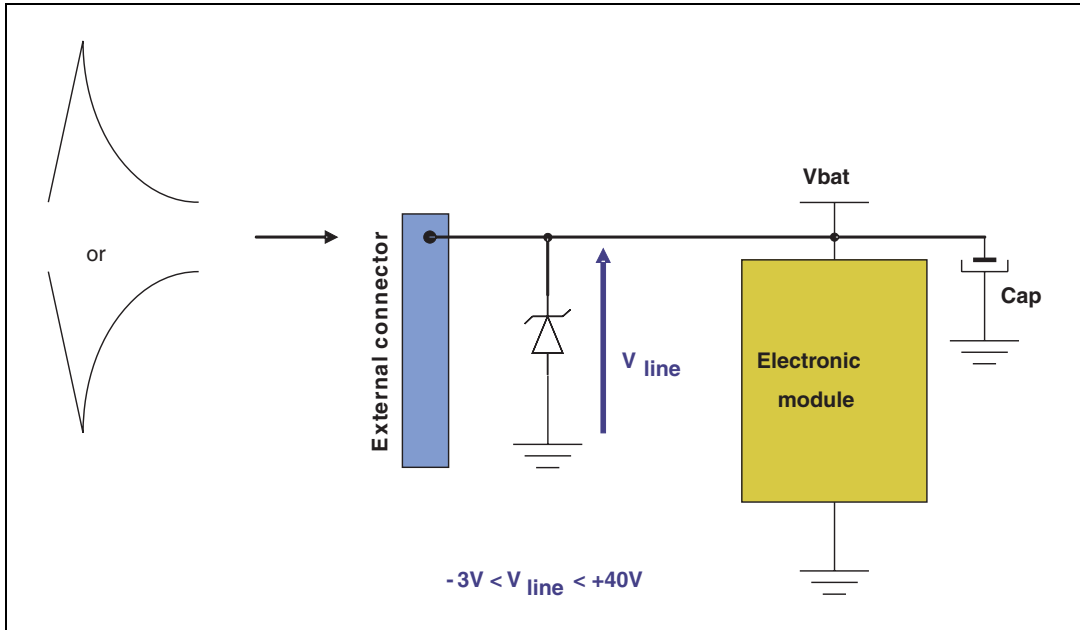

Figure 9, Figure 10, Figure 11, and Figure 12 show a test case example using a 25 V  $V_{bo}$  (breakover voltage) varistor compared to a 27 V  $V_{br}$  (breakdown voltage) asymmetrical Transil when submitted to pulse 2 and pulse 1 from ISO 7637-5 (see Figure 1). Figure 8 shows the test circuit.

**Figure 8. ISO 7637-2 pulse 1 and pulse 2 test setup**

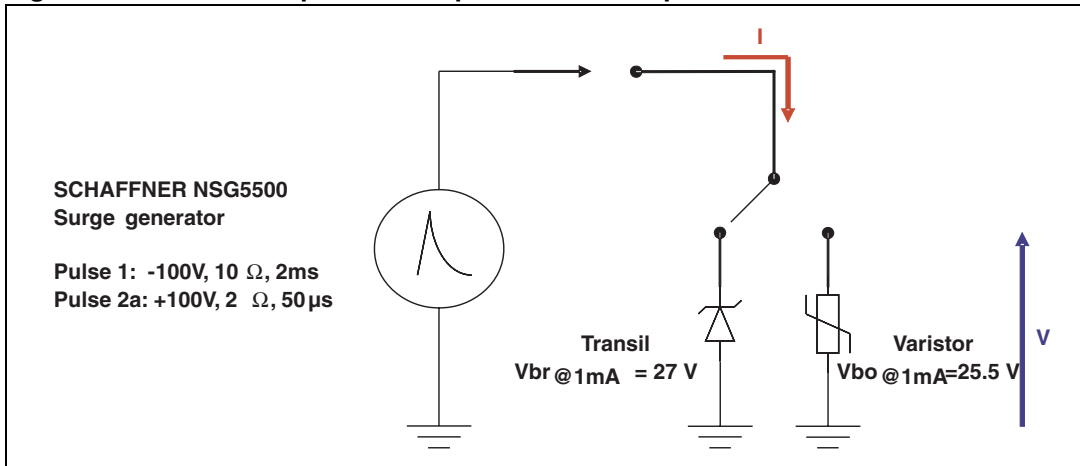

Figure 9. Asymmetrical Transil behavior when ISO 7637-2 pulse 2 is applied

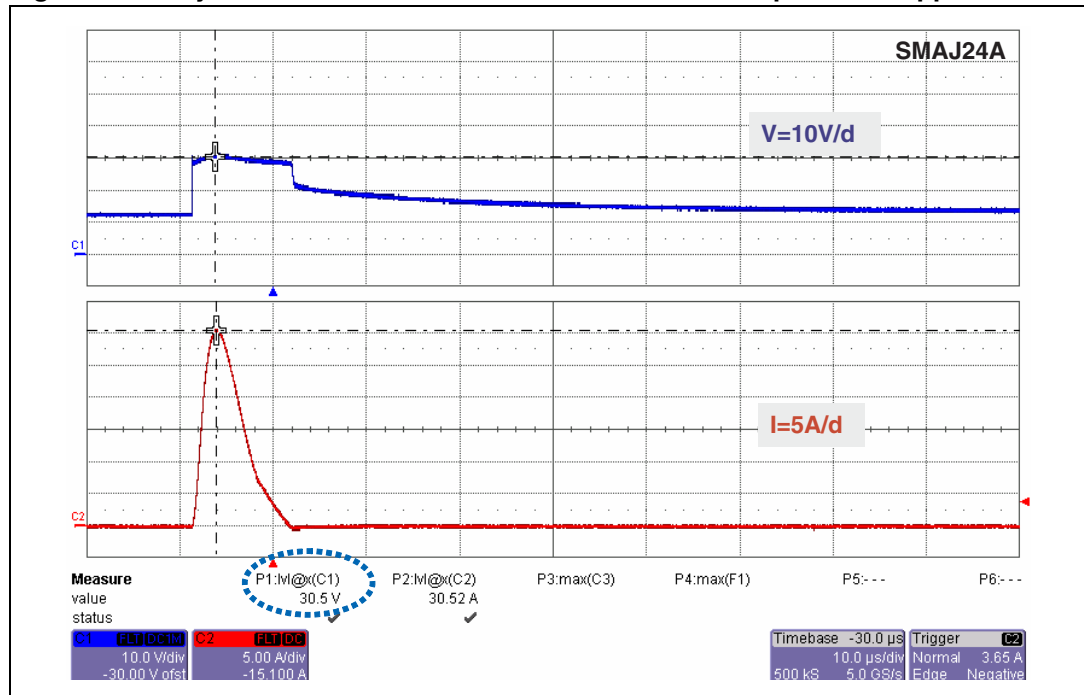

Figure 10. Varistor behavior when ISO 7637-2 pulse 2 is applied

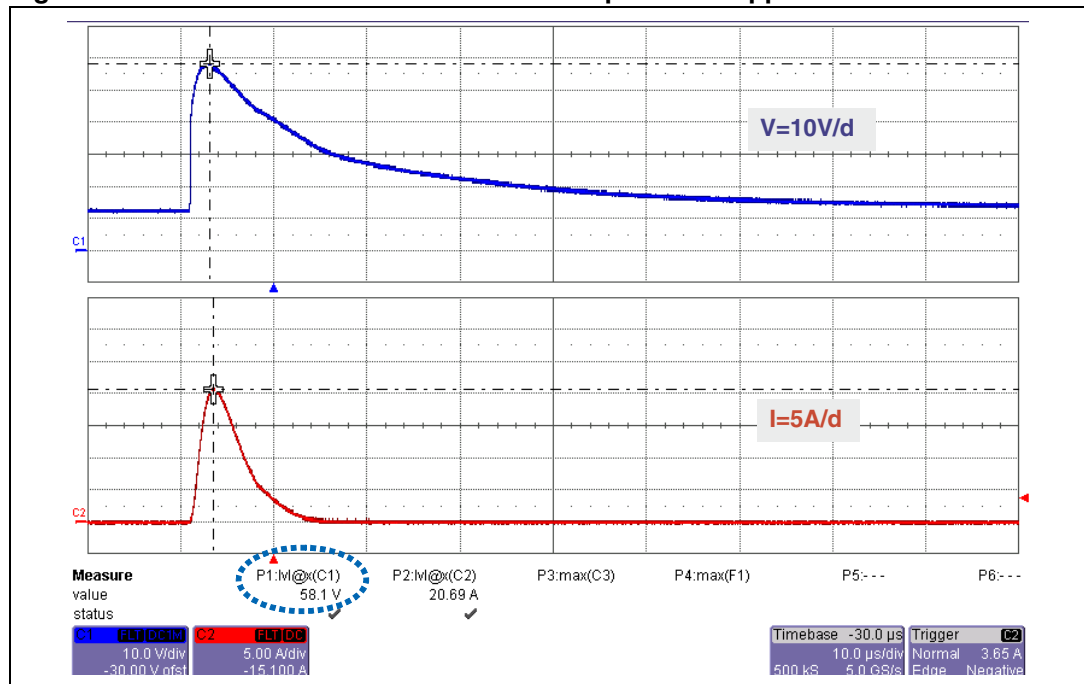

Figure 11. Asymmetrical Transil behavior when ISO 7637-2 pulse 1 is applied

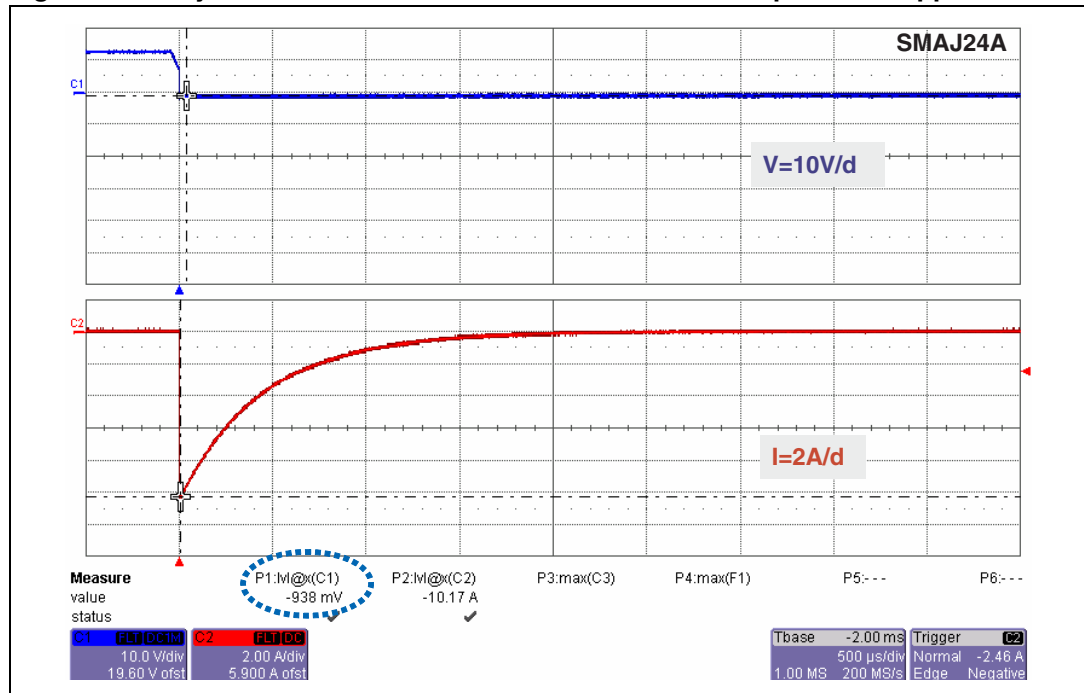
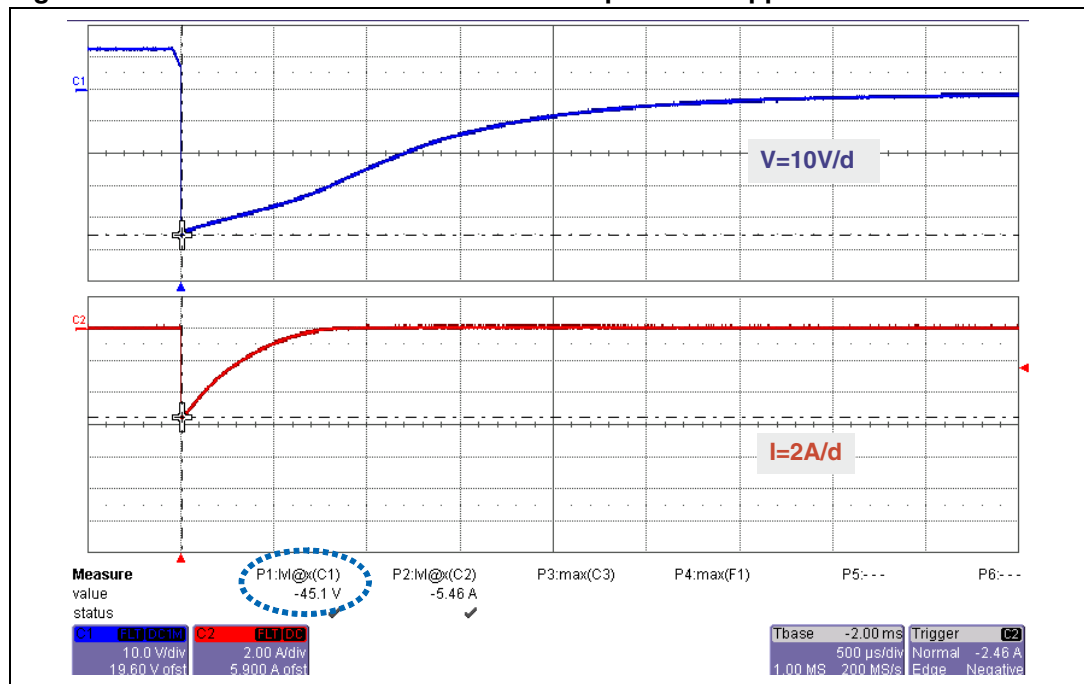

Figure 12. Varistor behavior when ISO 7637-2 pulse 1 is applied



The voltage behavior is quite different for the positive and negative surges between varistor and Transil. For the positive surge case the Transil clamping efficiency limits the overvoltage to 30 V whereas the varistor clamping level is about twice the Transil one.

The negative surge is clamped to few hundreds of millivolts with the Transil whereas the clamping voltage is close to -45 V with the varistor.

The test results shown in [Figure 9](#), [Figure 10](#), [Figure 11](#) and [Figure 12](#) indicate that protection effectiveness has marked differences when using a varistor or a Transil protection solution. The choice between the two solutions depends on the protection level needed.

Designers should not neglect the difference in the destruction mode between the two solutions. When a varistor is destroyed it turns into an open-circuit, thus no longer protecting the electronic module. When a Transil is damaged it becomes a short-circuit and still protects the electronic module.

However, varistors are still frequently used in automotive protection solutions. But, due to increasing electronic module susceptibility, varistors are often replaced by Transils or other accurate surge suppressors in the latest solutions.



## 2 Reverse polarity battery protection

Another vital consideration for protection solutions is the ability for the electronic module to withstand the reverse battery polarity test (see [Figure 1](#)). This test is defined in ISO 16750-2 standard to be a -14V test that last 60 s for 12 V systems.

For this reason all the electronic modules are equipped with a serial protection against the reverse polarity battery hazard. This serial protection typically consists of a fuse or a diode as shown in [Figure 13](#) and [Figure 14](#).

**Figure 13. Reverse polarity battery protection using a serial fuse**

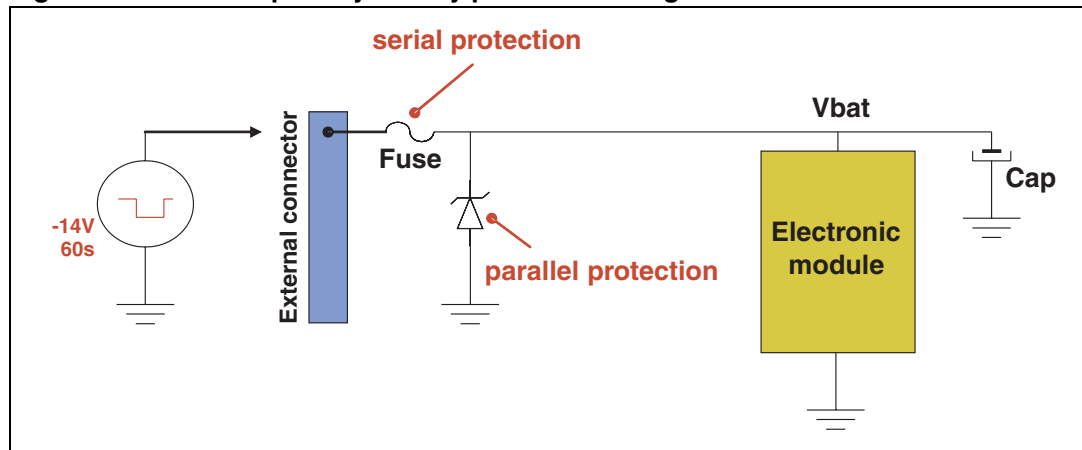

**Figure 14. Reverse polarity battery protection using a serial diode**

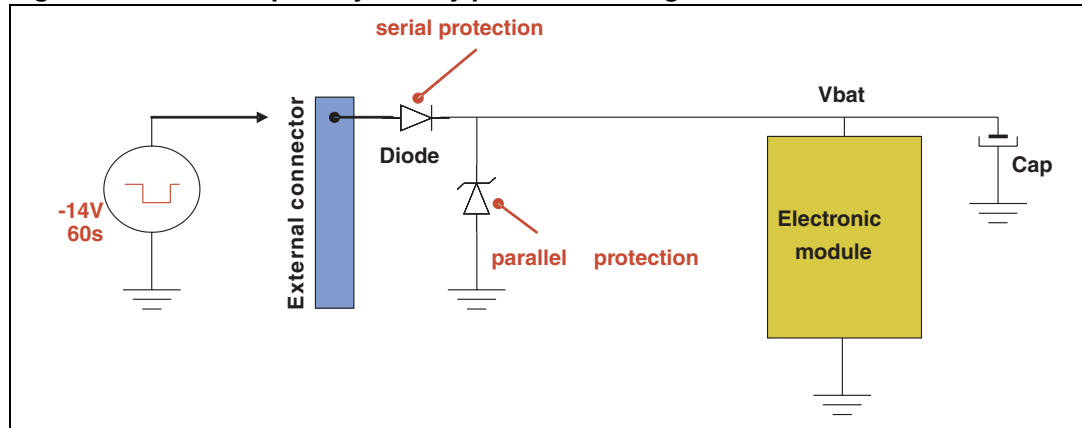

Considering the circuit in [Figure 13](#), when the reverse polarity battery test is applied the parallel protection, (an asymmetrical Transil), shorts the electrical overstress. Thus all the energy flows through the parallel protection and the fuse. The fuse blows and opens the circuit. The remaining voltage at the electronic module side is limited to some few hundreds of millivolts as the Transil diode acts in forward protection.

Note that there is no possibility to use a varistor in this case otherwise the residual voltage applied to the electronic module would be higher than the limits.

Considering the circuit in [Figure 14](#), when the reverse polarity battery test is applied, no current flows through the parallel protection made of an asymmetrical Transil, because the

serial protection using a diode blocks the negative overstress. Therefore there is no negative remaining voltage at the electronic module terminations.

The parallel protection does not act in this case but plays its role when positive surges are concerned.

Comparing the two solutions, both reverse polarity battery protection solutions show about the same performance. But the use of a fuse as a serial protection has its limitation due to the need of repair or replace blown fuses

In the case of a diode used as serial protection, first considerations might indicate that the only restriction we need is a reverse breaking voltage higher than the 14 V defined by the reverse polarity battery test specified in the ISO 16750 standard. But, this would not be correct because this serial reverse protection diode will have to withstand the negative electrical overstresses imposed by the ISO 7637-2 standard as well - in particular pulses 1 and 3a.

For this reason the breaking voltage of the serial protection diode will be rather 150 V minimum unless the serial reverse battery protection is made with a clamping device as in some cases.

There are also some cases where a clamping diode like Transil is used as serial reverse polarity battery protection combined with a conventional parallel protection. This is the case of the RBO40-40 that combines both protection in one die and complies with the ISO 10605, ISO 16750 and almost all ISO 7637-2 requirements.

This device is shown in [Figure 15](#).

**Figure 15. Complete protection solution using the RBO40-40**

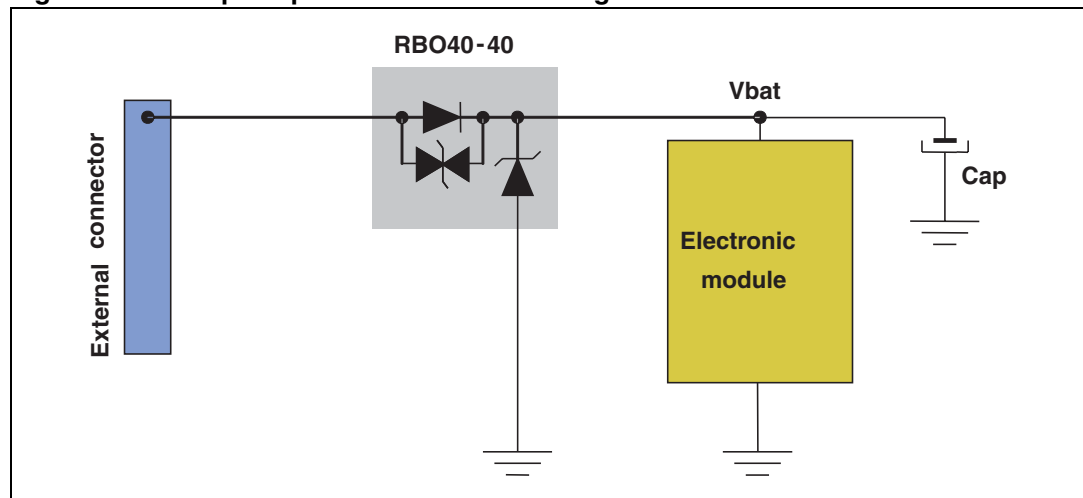

[Figure 17](#), [Figure 18](#) and [Figure 19](#) show the RBO40-40 behavior when submitted to ISO 7637-2 pulse 2 and pulse 1 and ISO 16750-2 reverse polarity battery test.

[Figure 16](#) shows the test circuit.

Figure 16. RBO40-40 test circuit schematic

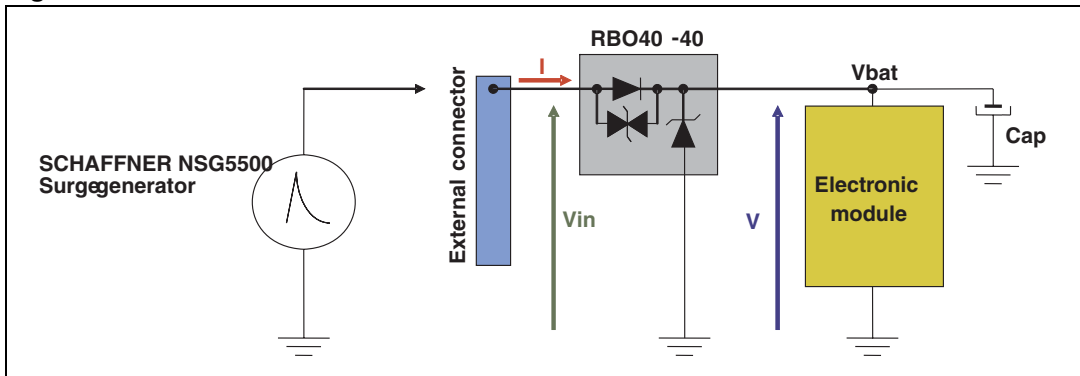

Figure 17. RBO40-40 behavior when submitted to ISO 7637-2 pulse 2

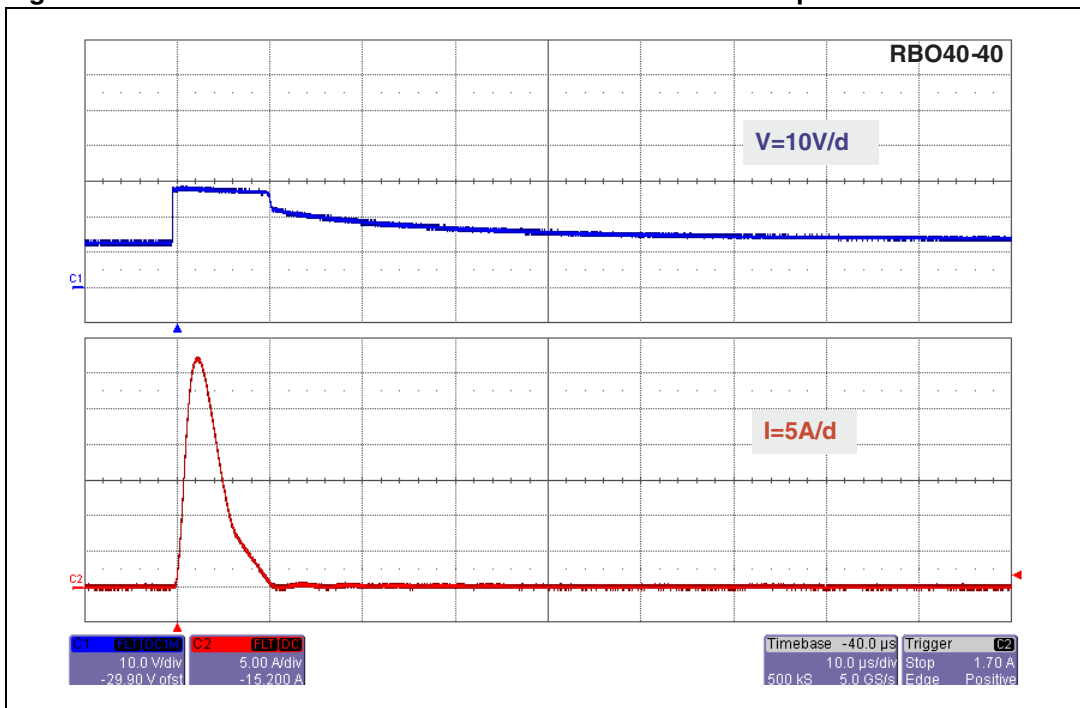

Figure 17 shows that the pulse 2 surge is clamped below 30 V, which fully protects the electronic module during the test.

Figure 18. RBO40-40 behavior when submitted to ISO 7637-2 pulse 1

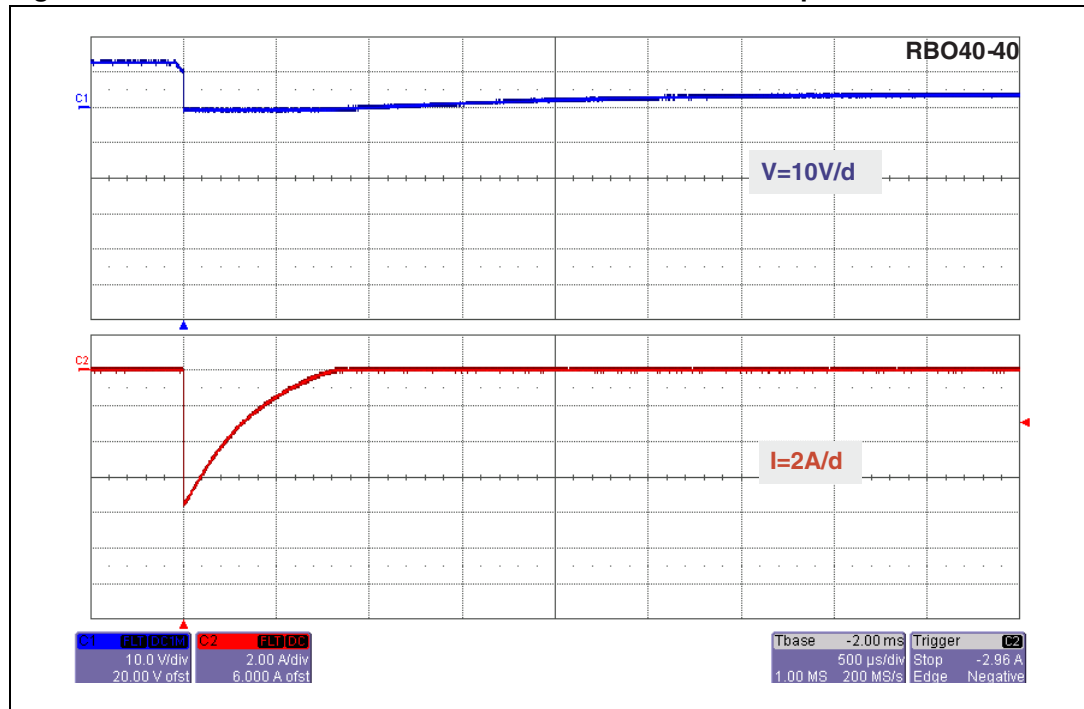
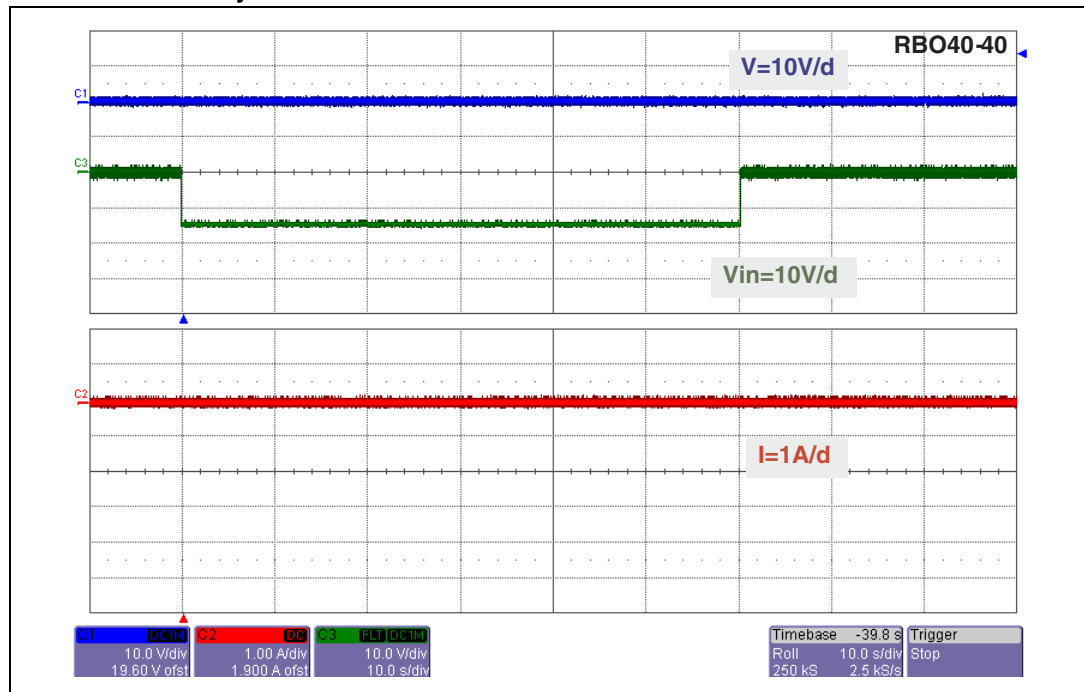

Figure 18 shows the remaining voltage after the protection device is some hundreds of millivolts negative. Thus the electronics can be well protected regarding negative surges.

Figure 19. RBO40-40 behavior when submitted to ISO 16750-2 reverse polarity battery test



*Figure 19* shows the behavior of the protection device behavior when reverse polarity of the battery is applied during 60 s. This figure shows that the reverse polarity battery test does not affect the protection device. No dissipation occurs inside the RBO40-40.

These results show that whatever the surge, the RBO40-40 satisfies both reverse polarity battery and overvoltage protection requirements.

Reverse polarity battery current is blocked thanks to the series internal diode for which the break-over ( $V_{br}$ ) voltage is higher than the test voltage. Higher negative voltage surges are clamped

RBO40-40 is able to withstand pulse 5 (see *Figure 1*) with the conditions given in *Table 1*.

**Table 1. ISO 7637-2 pulse 5 conditions for the RBO40-40 to withstand the surge**

Generator clamped voltage (V)	Pulse duration (ms)	Series resistor ( $\Omega$ )	$V_{bat}$ (V)
24	200	0.5	13.5
30		1	
36		1.5	
24	300	0.5	
30		1.5	
36		2	
24	400	0.5	
30		1.8	
36		2.2	

This device is also very efficient regarding ESD surges (positive or negative) and ensures complete protection of the electronic module.

### 3 Conclusion

All electronic modules that are designed for automotive environment should be equipped with protection devices that eliminate all kinds of electrical overstress and prevent the electronics from battery reverse polarity damage.

The RBO40-40 protection device is a high effective solution to achieve both electrical overstress and reverse polarity battery protection.

### 4 Revision history

**Table 2. Document revision history**

Date	Revision	Changes
30-Nov-2009	1	Initial release.

**Please Read Carefully:**

Information in this document is provided solely in connection with ST products. STMicroelectronics NV and its subsidiaries ("ST") reserve the right to make changes, corrections, modifications or improvements, to this document, and the products and services described herein at any time, without notice.

All ST products are sold pursuant to ST's terms and conditions of sale.

Purchasers are solely responsible for the choice, selection and use of the ST products and services described herein, and ST assumes no liability whatsoever relating to the choice, selection or use of the ST products and services described herein.

No license, express or implied, by estoppel or otherwise, to any intellectual property rights is granted under this document. If any part of this document refers to any third party products or services it shall not be deemed a license grant by ST for the use of such third party products or services, or any intellectual property contained therein or considered as a warranty covering the use in any manner whatsoever of such third party products or services or any intellectual property contained therein.

**UNLESS OTHERWISE SET FORTH IN ST'S TERMS AND CONDITIONS OF SALE ST DISCLAIMS ANY EXPRESS OR IMPLIED WARRANTY WITH RESPECT TO THE USE AND/OR SALE OF ST PRODUCTS INCLUDING WITHOUT LIMITATION IMPLIED WARRANTIES OF MERCHANTABILITY, FITNESS FOR A PARTICULAR PURPOSE (AND THEIR EQUIVALENTS UNDER THE LAWS OF ANY JURISDICTION), OR INFRINGEMENT OF ANY PATENT, COPYRIGHT OR OTHER INTELLECTUAL PROPERTY RIGHT.**

**UNLESS EXPRESSLY APPROVED IN WRITING BY AN AUTHORIZED ST REPRESENTATIVE, ST PRODUCTS ARE NOT RECOMMENDED, AUTHORIZED OR WARRANTED FOR USE IN MILITARY, AIR CRAFT, SPACE, LIFE SAVING, OR LIFE SUSTAINING APPLICATIONS, NOR IN PRODUCTS OR SYSTEMS WHERE FAILURE OR MALFUNCTION MAY RESULT IN PERSONAL INJURY, DEATH, OR SEVERE PROPERTY OR ENVIRONMENTAL DAMAGE. ST PRODUCTS WHICH ARE NOT SPECIFIED AS "AUTOMOTIVE GRADE" MAY ONLY BE USED IN AUTOMOTIVE APPLICATIONS AT USER'S OWN RISK.**

Resale of ST products with provisions different from the statements and/or technical features set forth in this document shall immediately void any warranty granted by ST for the ST product or service described herein and shall not create or extend in any manner whatsoever, any liability of ST.

ST and the ST logo are trademarks or registered trademarks of ST in various countries.

Information in this document supersedes and replaces all information previously supplied.

The ST logo is a registered trademark of STMicroelectronics. All other names are the property of their respective owners.

© 2009 STMicroelectronics - All rights reserved

STMicroelectronics group of companies

Australia - Belgium - Brazil - Canada - China - Czech Republic - Finland - France - Germany - Hong Kong - India - Israel - Italy - Japan - Malaysia - Malta - Morocco - Philippines - Singapore - Spain - Sweden - Switzerland - United Kingdom - United States of America

[www.st.com](http://www.st.com)