

## Discovery kit with STM32F407VG MCU

### Introduction

The STM32F4DISCOVERY Discovery kit allows users to develop applications with the STM32F407VG high-performance microcontroller with the Arm<sup>®</sup> Cortex<sup>®</sup>-M4 32-bit core. It includes everything for beginners or experienced users to get started quickly.

Based on STM32F407VG, it includes an ST-LINK/V2-A embedded debug tool, one MEMS digital accelerometer, one digital microphone, one audio DAC with integrated class D speaker driver, LEDs, push-buttons, and a USB OTG Micro-AB connector. Specialized expansion boards can be connected using the extension header connectors. The STM32F4DISCOVERY Discovery kit comes with the STM32 comprehensive free software libraries and examples available in the STM32CubeF4 MCU Package.

Figure 1. STM32F4DISCOVERY

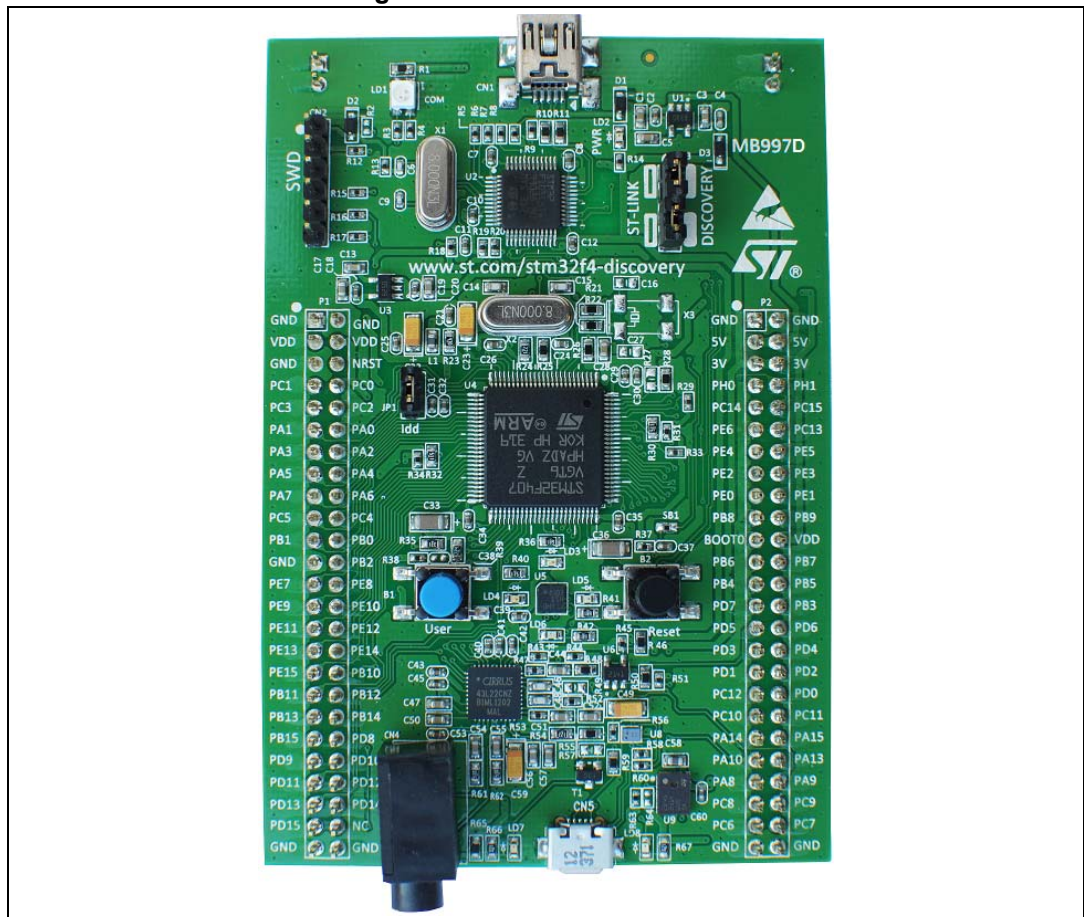

Picture is not contractual.

# Contents

- 1      Features ..... 6**
- 2      Ordering information ..... 7**
  - 2.1    Codification ..... 7
- 3      Development environment ..... 8**
  - 3.1    System requirements ..... 8
  - 3.2    Development toolchains ..... 8
  - 3.3    Demonstration software ..... 8
  - 3.4    EDA resources ..... 8
- 4      Conventions ..... 9**
- 5      Safety recommendations ..... 10**
  - 5.1    Targeted audience ..... 10
  - 5.2    Handling the board ..... 10
  - 5.3    Delivery recommendations ..... 10
  - 5.4    Power supply ..... 10
- 6      Quick start ..... 11**
  - 6.1    Getting started ..... 11
- 7      Hardware and layout and configuration ..... 12**
  - 7.1    Hardware layout ..... 12
  - 7.2    Mechanical dimensions ..... 15
  - 7.3    Embedded ST-LINK/V2-A ..... 16
    - 7.3.1    Drivers ..... 17
    - 7.3.2    ST-LINK/V2-A firmware upgrade ..... 17
    - 7.3.3    ST-LINK/V2-A VCP configuration ..... 18
    - 7.3.4    Using ST-LINK/V2-A to program/debug the STM32F407VG on board . 19
    - 7.3.5    Using ST-LINK/V2-A to program/debug an external STM32 application 20
  - 7.4    Power supply and power selection ..... 21
  - 7.5    LEDs ..... 21

7.6	Push-buttons	21
7.7	On-board audio capability	22
7.8	USB OTG supported	22
7.9	Motion sensor	22
7.10	JP1 (Idd)	22
7.11	Clock sources	23
7.11.1	OSC clock supply	23
7.11.2	OSC 32 KHz clock supply	23
7.12	Solder bridges	24
7.13	Extension connectors	25
<b>8</b>	<b>STM32F4DISCOVERY Discovery kit information</b>	<b>32</b>
8.1	Product marking	32
8.2	STM32F4DISCOVERY product history	33
8.3	Board revision history	35
<b>9</b>	<b>Compliance statements and conformity declarations</b>	<b>36</b>
9.1	Federal Communications Commission (FCC) compliance statement	36
9.2	Innovation, Science and Economic Development Canada (ISED) compliance statement	37
9.3	UKCA conformity	37
9.4	CE conformity	37
9.4.1	Simplified EU declaration of conformity	37
9.4.2	Déclaration de conformité UE simplifiée	37
<b>10</b>	<b>Product disposal</b>	<b>38</b>
<b>11</b>	<b>Revision history</b>	<b>39</b>

## List of tables

Table 1.	Ordering information . . . . .	7
Table 2.	Codification explanation . . . . .	7
Table 3.	ON/OFF conventions . . . . .	9
Table 4.	Jumper states . . . . .	16
Table 5.	Debug connector CN2 (SWD) . . . . .	20
Table 6.	Solder bridges . . . . .	24
Table 7.	STM32 pin description versus board functions . . . . .	26
Table 8.	Product history . . . . .	33
Table 9.	Board revision history . . . . .	35
Table 10.	Document revision history . . . . .	39

## List of figures

Figure 1.	STM32F4DISCOVERY .....	1
Figure 2.	Hardware block diagram .....	12
Figure 3.	STM32F4DISCOVERY top layout .....	13
Figure 4.	STM32F4DISCOVERY bottom layout .....	14
Figure 5.	STM32F4DISCOVERY mechanical drawing .....	15
Figure 6.	USB Composite Device .....	17
Figure 7.	ST-LINK VCP connection to USART2 .....	18
Figure 8.	STM32F4DISCOVERY connections .....	19
Figure 9.	ST-LINK connections .....	20

# 1 Features

The STM32F4DISCOVERY offers the following features:

- STM32F407VGT6 microcontroller featuring 32-bit Arm<sup>®(a)</sup> Cortex<sup>®</sup>-M4 with FPU core, 1-Mbyte flash memory, and 192-Kbyte RAM in an LQFP100 package
- USB OTG FS
- MEMS 3-axis accelerometer
- MEMS audio sensor omnidirectional digital microphone
- Audio DAC with integrated class D speaker driver
- User and reset push-buttons
- Eight LEDs:
  - LD1 (red/green) for USB communication
  - LD2 (red) for 3.3 V power on
  - Four user LEDs, LD3 (orange), LD4 (green), LD5 (red) and LD6 (blue)
  - Two USB OTG LEDs, LD7 (green)  $V_{BUS}$  and LD8 (red) over-current
- Board connectors:
  - USB with Micro-AB
  - Stereo headphone output jack
  - 2.54 mm pitch extension header for all LQFP100 I/Os for quick connection to prototyping board and easy probing
- Flexible power-supply options: ST-LINK, USB  $V_{BUS}$ , or external sources
- External application power supply: 3 V and 5 V
- Comprehensive free software including a variety of examples, part of STM32CubeF4 MCU Package, or STSW-STM32068 for using legacy standard libraries
- On-board ST-LINK/V2-A debugger/programmer with USB re-enumeration capability: mass storage, Virtual COM port, and debug port
- Support of a wide choice of Integrated Development Environments (IDEs) including IAR Embedded Workbench<sup>®</sup>, MDK-ARM, and STM32CubeIDE



---

a. Arm and Cortex are registered trademarks of Arm Limited (or its subsidiaries or affiliates) in the US and/or elsewhere.  
The Arm word and logo are trademarks of Arm Limited (or its subsidiaries) in the US and/or elsewhere. All rights reserved.

## 2 Ordering information

To order the Discovery kit for the STM32F407 product line of microcontrollers, refer to [Table 1](#). Additional information is available from the datasheet and reference manual of the target microcontroller.

**Table 1. Ordering information**

Order code	Board reference	Target STM32
STM32F407G-DISC1 <sup>(1)</sup>	MB997 <sup>(2)</sup>	STM32F407VGT6

1. STM32F407G-DISC1 with ST-LINK/V2-A replaces the obsolete STM32F4DISCOVERY order code with ST-LINK/V2.
2. Subsequently called main board in the rest of the documentation.

### 2.1 Codification

The meaning of the codification is explained in [Table 2](#).

**Table 2. Codification explanation**

STM32F4XXY-DISCN	Description	Example: STM32F407G-DISC1
STM32F4	MCU series in STM32 32-bit Arm Cortex MCUs	STM32F4 series
XX	MCU product line in the series	STM32F407 product line
Y	STM32 flash memory size: – G for 1 Mbyte	1 Mbyte
DISC	Discovery kit	Discovery kit
N	Sequential number	First version

## 3 Development environment

### 3.1 System requirements

- Windows® 10 or 11, Linux® 64-bit, or macOS® (a)
- USB Type-A or USB Type-C® to Mini-B cable

### 3.2 Development toolchains

- IAR Systems® - IAR Embedded Workbench® (b)
- Keil® - MDK-ARM<sup>(b)</sup>
- STMicroelectronics - STM32CubeIDE

### 3.3 Demonstration software

The demonstration software, included in the STM32Cube MCU Package corresponding to the on-board microcontroller, is preloaded in the STM32 flash memory for easy demonstration of the device peripherals in standalone mode. The latest versions of the demonstration source code and associated documentation can be downloaded from [www.st.com](http://www.st.com).

### 3.4 EDA resources

All board design resources, including schematics, EDA databases, manufacturing files, and the bill of materials are available from the STM32F4DISCOVERY product page at [www.st.com](http://www.st.com).

---

a. macOS® is a trademark of Apple Inc. registered in the U.S. and other countries.  
All other trademarks are the property of their respective owners.

b. On Windows® only.

## 4 Conventions

[Table 3](#) provides the conventions used for the ON and OFF settings in the present document.

**Table 3. ON/OFF conventions**

<b>Convention</b>	<b>Definition</b>
Jumper JPx ON	Jumper fitted
Jumper JPx OFF	Jumper not fitted
Jumper JPx [1-2]	Jumper fitted between Pin 1 and Pin 2
Solder bridge SBx ON	SBx connections closed by 0 $\Omega$ resistor
Solder bridge SBx OFF	SBx connections left open
Resistor Rx ON	Resistor soldered
Resistor Rx OFF	Resistor not soldered

## 5 Safety recommendations

### 5.1 Targeted audience

This product targets users with at least basic electronics or embedded software development knowledge such as engineers, technicians, or students.

This board is not a toy and is not suited for use by children.

### 5.2 Handling the board

This product contains a bare printed circuit board and like all products of this type, the user must be careful about the following points:

- The connection pins on the board might be sharp. Be careful when handling the board to avoid injury.
- This board contains static sensitive devices. To avoid damaging it, handle the board in an ESD-proof environment.
- While powered, do not touch the electric connections on the board with your fingers or anything conductive.
- The board operates at a voltage level that is not dangerous, but components might be damaged when shorted.
- Do not put any liquid on the board and avoid operating it close to water or at a high humidity level.
- Do not operate the board if it is dirty or dusty.
- The pins of the board are exposed and must not come into contact with a metal surface, as this can produce a short circuit and damage the board.

### 5.3 Delivery recommendations

Before the first use, inspect the board for any damage that may have occurred during shipment. Ensure that all socketed components are securely fixed in their sockets and that nothing is loose in the plastic bag.

### 5.4 Power supply

A power supply unit or auxiliary equipment complying with the EN 62368-1:2014+A11:2017 standard (or the one replacing it) and safety extralow voltage (SELV/ES1) with limited power capability (LPS/PS2) must power this equipment.

## 6 Quick start

The STM32F4DISCOVERY is a low-cost and easy-to-use development kit to quickly evaluate and start development with an STM32F407VGT6 high-performance microcontroller.

Before installing and using the product, accept the evaluation product license agreement from the [www.st.com/epla](http://www.st.com/epla) webpage.

For more information on the STM32F4DISCOVERY and demonstration software, visit the [www.st.com/en/product/stm32f4discovery](http://www.st.com/en/product/stm32f4discovery) webpage.

### 6.1 Getting started

Follow the sequence below to configure the STM32F4DISCOVERY board and launch the DISCOVER application:

1. Check the jumper positions on the board: JP1 ON, CN3 ON (DISCOVERY selected).
2. Connect the STM32F4DISCOVERY board to a PC with a USB Type-A or USB Type-C<sup>®</sup> to Mini-B cable through USB connector CN1 to power the board. Red LED LD2 (PWR) then lights up.
3. Four LEDs between buttons B1 and B2 are blinking.
4. Press user button B1 to enable the MEMS sensor, move the board, and observe the four LEDs blinking according to the motion direction and speed. (If a second USB Type-A or USB Type-C<sup>®</sup> to Mini-B cable is connected between the PC and CN5 connector, then the board is recognized as a standard mouse and its motion will also control the PC cursor).
5. To study or modify the DISCOVER project related to this demonstration, visit the [www.st.com/stm32f4-discovery](http://www.st.com/stm32f4-discovery) webpage and follow the tutorial.
6. Discover the STM32F407VG features, download and execute programs proposed in the list of projects.
7. Develop the application using available examples.

# 7 Hardware and layout and configuration

## 7.1 Hardware layout

The STM32F4DISCOVERY is designed around the STM32F407VGT6 microcontroller in a 100-pin LQFP package.

Figure 2 illustrates the connections between the STM32F407VGT6 and its peripherals (ST-LINK/V2-A, push buttons, LEDs, audio DAC, USB, MEMS accelerometer and microphone, and connectors).

Figure 3 and Figure 4 help users locate these features on the STM32F4DISCOVERY board.

Figure 2. Hardware block diagram

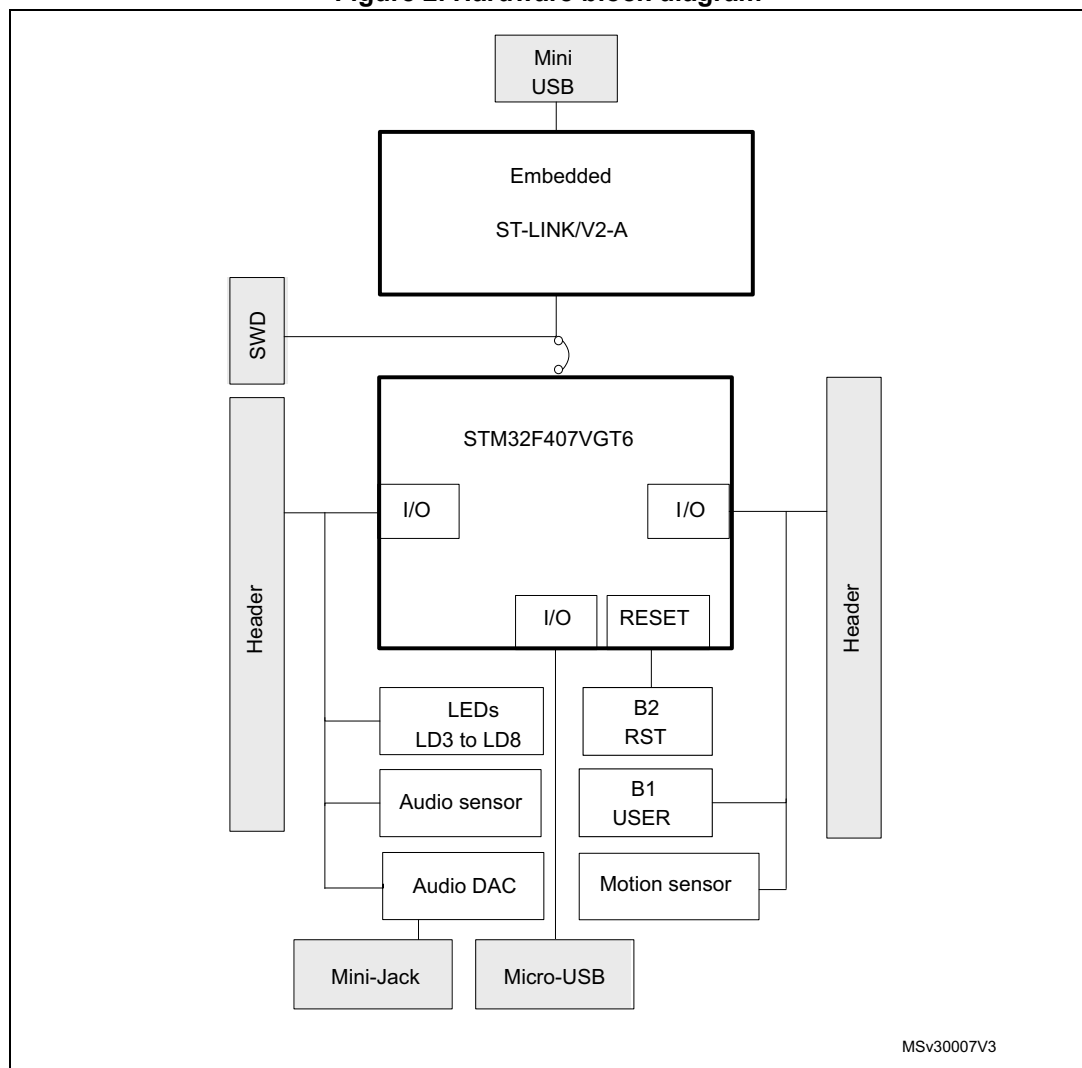
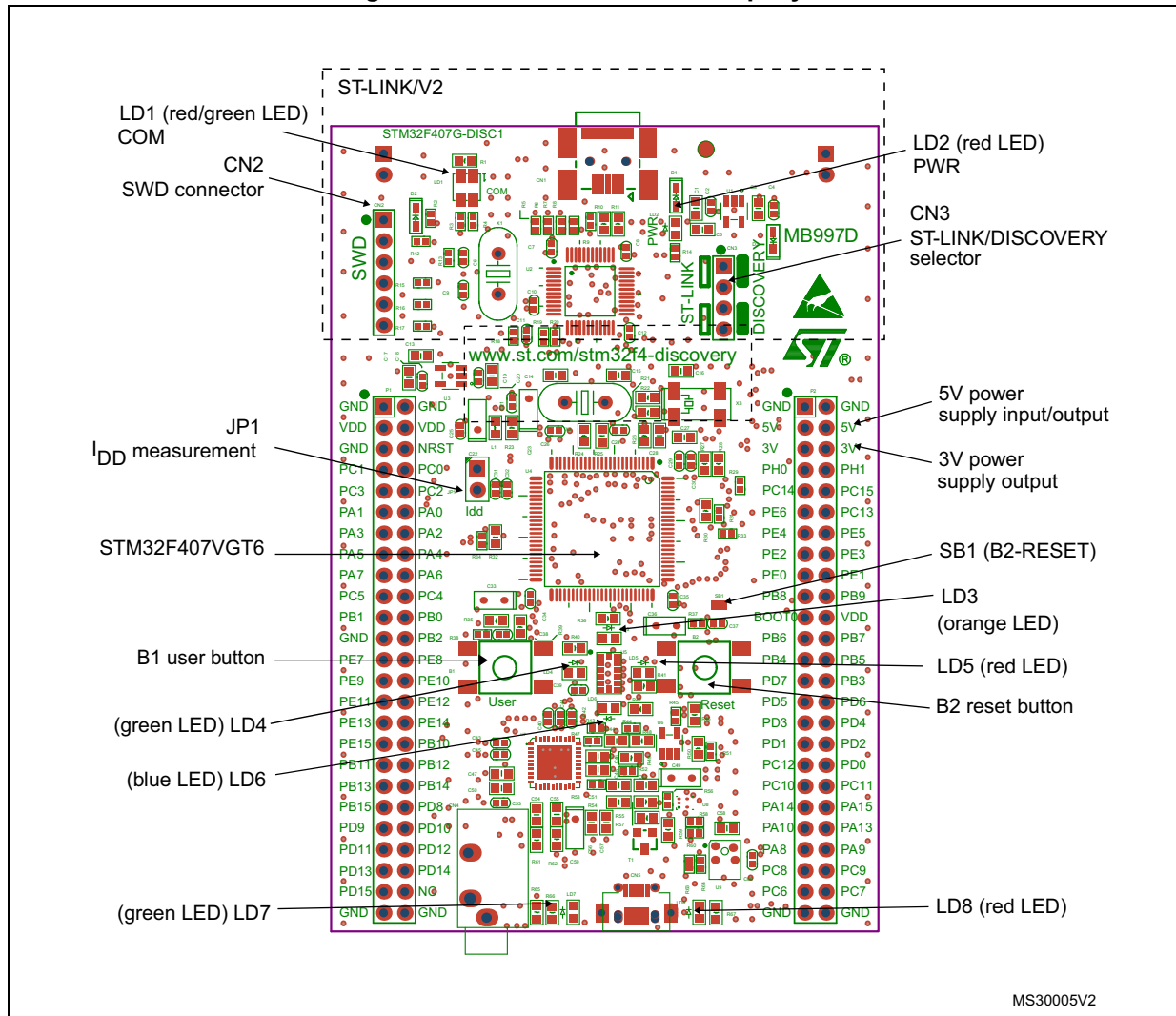
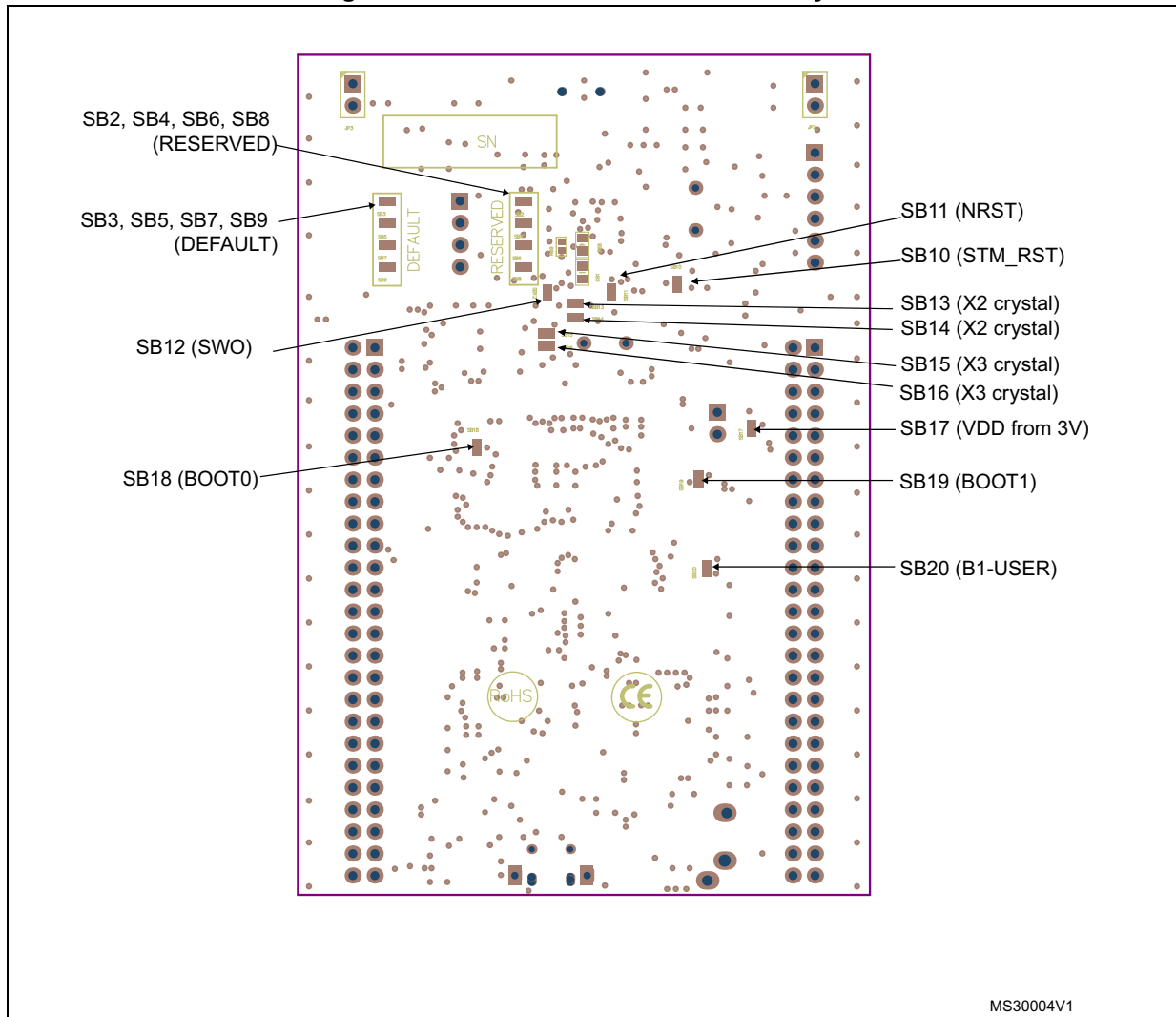

Figure 3. STM32F4DISCOVERY top layout



Note: Pin 1 of CN2, CN3, JP1, P1, and P2 connectors are identified by a red square.

Figure 4. STM32F4DISCOVERY bottom layout



## 7.2 Mechanical dimensions

Figure 5. STM32F4DISCOVERY mechanical drawing

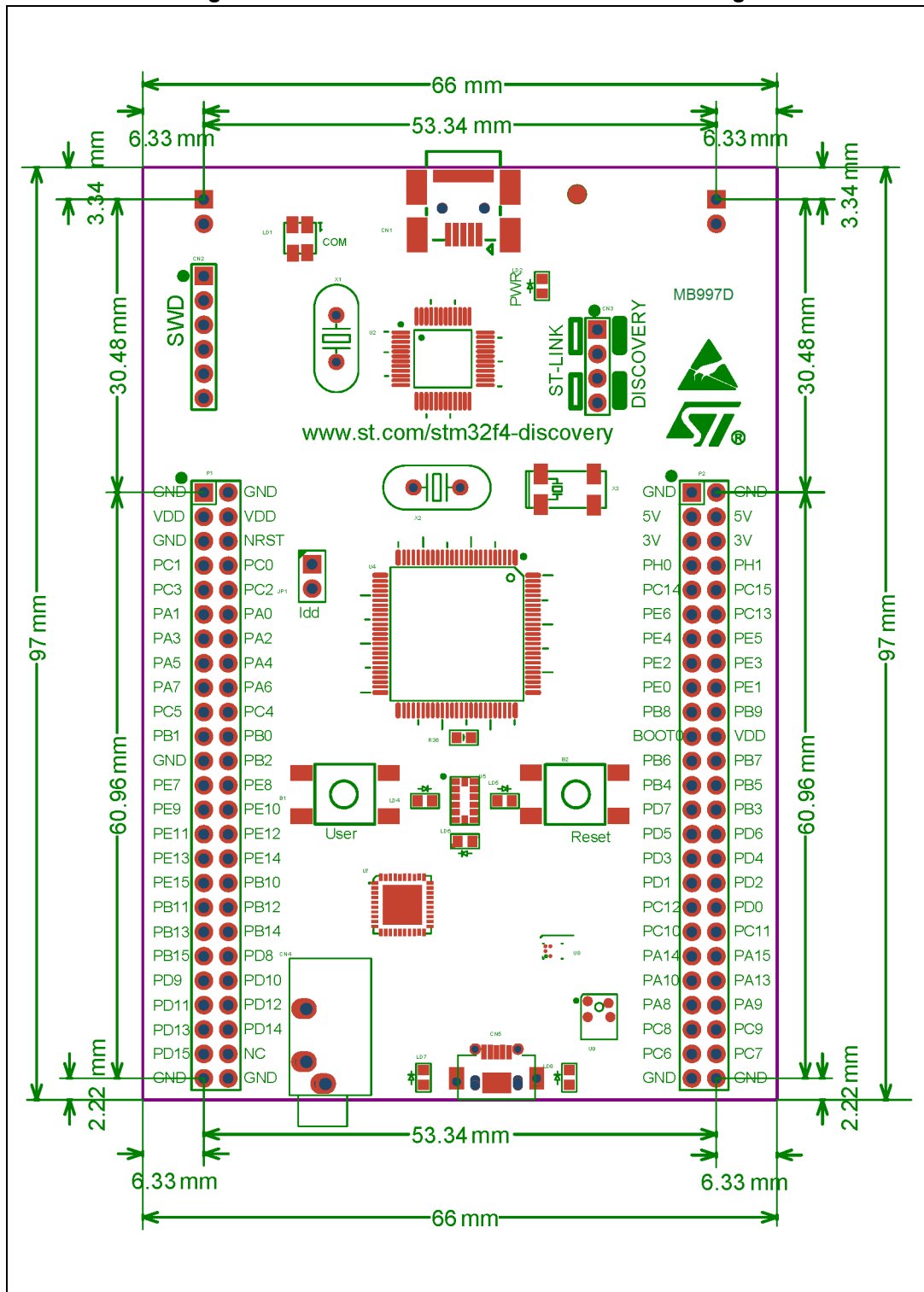

## 7.3 Embedded ST-LINK/V2-A

ST-LINK/V2-A<sup>(a)</sup> is an embedded tool for programming and debugging.

The embedded ST-LINK/V2-A supports only SWD for STM32 devices.

For information about the debugging and programming features refer to the user manual *ST-LINK/V2 in-circuit debugger/programmer for STM8 and STM32* (UM1075). To compare the various ST-LINK solutions, refer to the technical note *Overview of ST-LINK derivatives* (TN1235).

Features supported with ST-LINK/V2-A:

- Virtual COM port interface on USB (see [Section 7.3.3: ST-LINK/V2-A VCP configuration](#))
- Mass storage interface on USB

Features not supported with ST-LINK/V2-A:

- SWIM interface
- Minimum supported application voltage limited to 3 V
- USB power management request for more than 100 mA power on USB

Known limitation:

- Activating the readout protection on an ST-LINK/V2-A target prevents the target application from running afterward. The target readout protection must be kept disabled on ST-LINK/V2-A boards.

There are two different ways to use the embedded ST-LINK/V2-A depending on the jumper states (see [Table 4](#)):

- Program/debug the STM32 on board (refer to [Section 7.3.4: Using ST-LINK/V2-A to program/debug the STM32F407VG on board](#))
- Program/debug the STM32 in an external application board, using a cable connected to SWD connector CN2 (refer to [Section 7.3.5: Using ST-LINK/V2-A to program/debug an external STM32 application](#))

**Table 4. Jumper states**

Jumper state	Description
Both CN3 jumpers ON	ST-LINK/V2-A functions enabled for on-board programming (default)
Both CN3 jumpers OFF	ST-LINK/V2-A functions enabled for application through external CN2 connector (SWD supported)

a. The features described in this section apply also to ST-LINK/V2, which is the debugger/programmer embedded in the obsolete Discovery kit with order code STM32F4DISCOVERY. Only [Section 7.3.3: ST-LINK/V2-A VCP configuration](#) is specific to the Discovery kit with order code STM32F407G-DISC1.

### 7.3.1 Drivers

Before connecting the STM32F4DISCOVERY board to a Windows® PC (7, 8, and 10) through the USB, a driver for the ST-LINK/V2-A must be installed. It is available at the [www.st.com](http://www.st.com) website. In case the STM32 Discovery board is connected to the PC before the driver is installed, some Discovery interfaces might be declared as *Unknown* in the PC device manager. To recover from this situation, after installing the dedicated driver, the association of “Unknown” USB devices found on the STM32F4DISCOVERY board to this dedicated driver, must be updated in the device manager manually.

*Note:* It is recommended to proceed by using the USB Composite Device, as shown in [Figure 6](#).

Figure 6. USB Composite Device

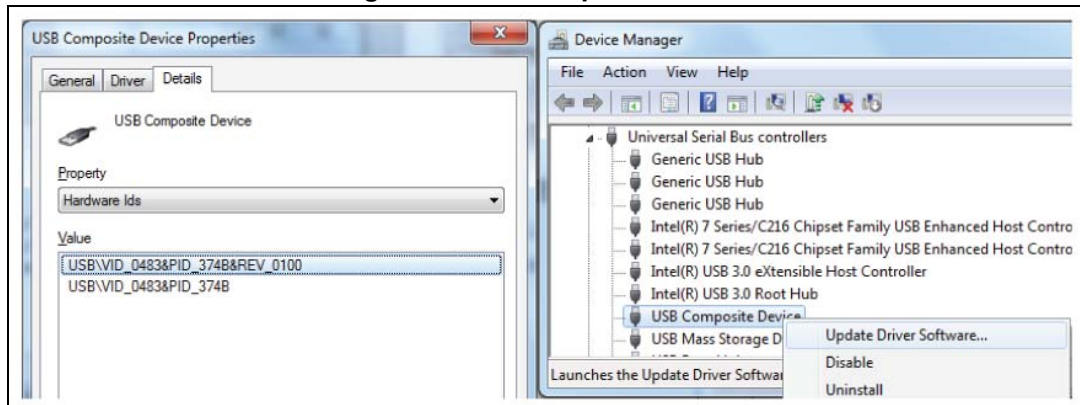

### 7.3.2 ST-LINK/V2-A firmware upgrade

The ST-LINK/V2-A embeds a firmware upgrade mechanism for in-place upgrade through the USB port. As the firmware might evolve during the lifetime of the ST-LINK/V2-A product (for example new functionalities, bug fixes, and support for new microcontroller families), it is recommended to visit the [www.st.com](http://www.st.com) website before starting to use the Discovery board and periodically stay up-to-date with the latest firmware version.

### 7.3.3 ST-LINK/V2-A VCP configuration

The ST-LINK/V2-A supports a Virtual COM port (VCP) on U2 pin 12 (ST-LINK\_TX) and U2 pin 13 (ST-LINK\_RX) but these pins are not connected to the USART of the STM32F407 microcontroller.

Two solutions are possible to connect an STM32F407 USART to the VCP on the PC:

- Using a USART to USB dongle from the market connected for instance to STM32F407 USART2 available on connector P1 pin 14 (PA2: USART2\_TX) and P1 pin 13 (PA3: USART2\_RX).
- Using flying wires to connect ST-LINK/V2-A Virtual COM port (ST-LINK VCP on U2 pin 12 and 13) to STM32F407 USART2 (PA2 and PA3: P1 pin 14 and 13) as shown in [Figure 7](#).

Figure 7. ST-LINK VCP connection to USART2

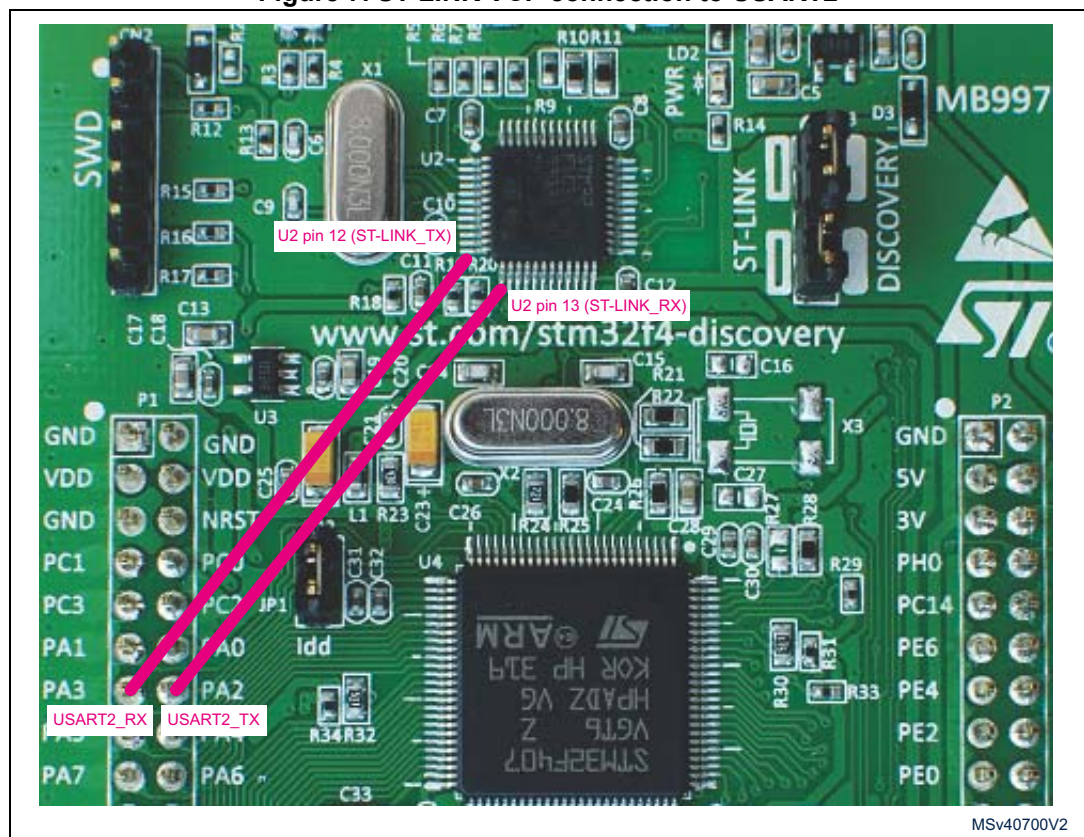

### 7.3.4 Using ST-LINK/V2-A to program/debug the STM32F407VG on board

To program the STM32F407VG on board, plug in the two jumpers on CN3, as shown in [Figure 8](#) in yellow, but do not use the CN2 connector as that could disturb communication with the STM32F407VG of the STM32F4DISCOVERY.

Figure 8. STM32F4DISCOVERY connections

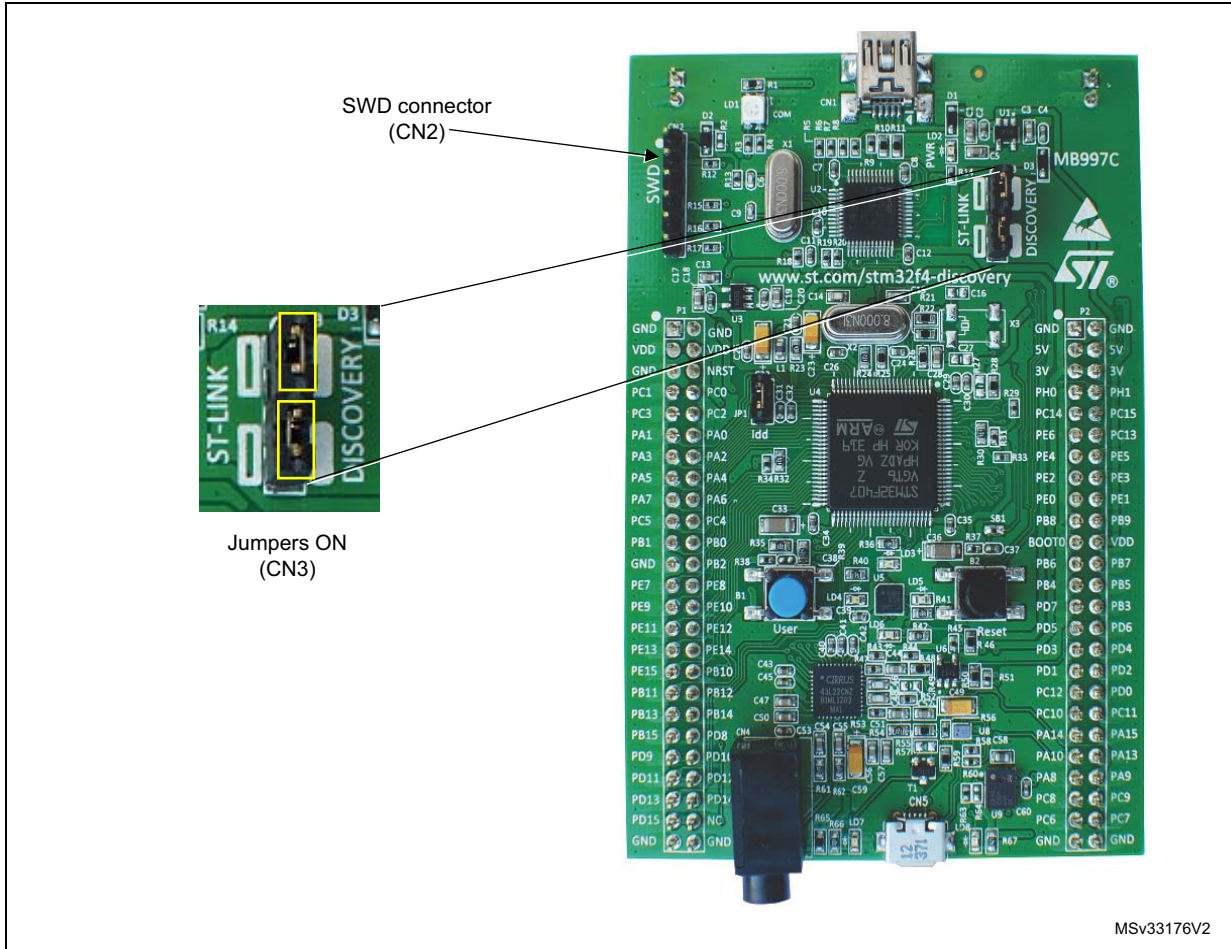

### 7.3.5 Using ST-LINK/V2-A to program/debug an external STM32 application

It is very easy to use the ST-LINK/V2-A to program the STM32 on an external application. Simply remove the two jumpers from CN3, as shown in [Figure 9](#), and connect the application to the CN2 debug connector according to [Table 5](#).

*Note:* SB11 must be OFF if CN2 pin 5 is used in the external application.

**Table 5. Debug connector CN2 (SWD)**

Pin	CN2	Designation
1	VDD_TARGET	VDD from application
2	SWCLK	SWD clock
3	GND	Ground
4	SWDIO	SWD data input/output
5	NRST	RESET of target STM32
6	SWO	Reserved

**Figure 9. ST-LINK connections**

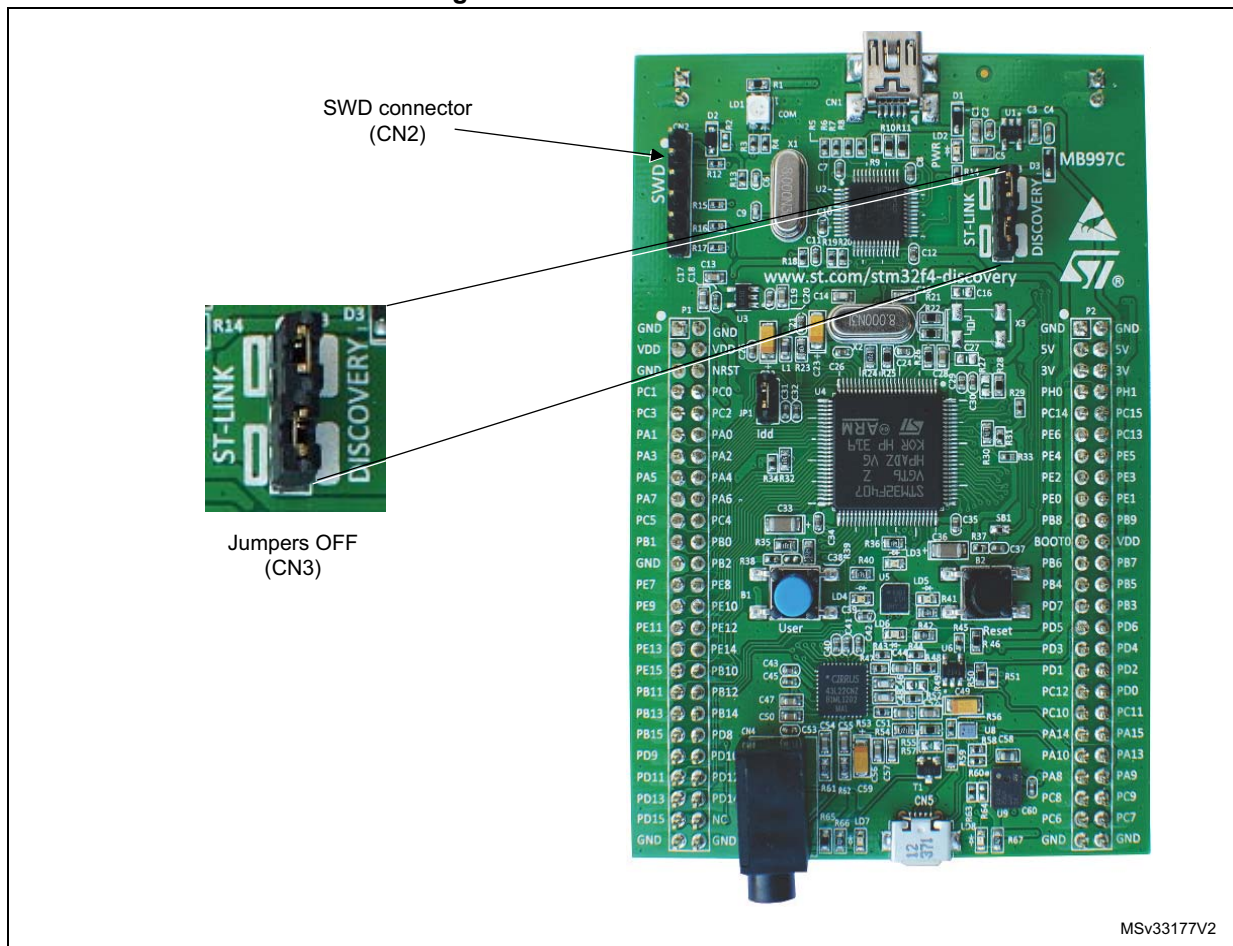

MSV33177V2

## 7.4 Power supply and power selection

The power supply is provided either by the host PC through the USB cable, or by an external 5 V power supply.

The D1 and D2 diodes protect the 5V and 3V pins from external power supplies:

- 5V and 3V can be used as output power supplies when another application board is connected to pins P1 and P2.  
In this case, the 5V and 3V pins deliver a 5 V or 3 V power supply and power consumption must be lower than 100 mA.
- 5V can also be used as input power supplies, for instance when the USB connector is not connected to the PC.

## 7.5 LEDs

- LD1 COM: The LD1 default status is red. LD1 turns to green to indicate that communications are in progress between the PC and the ST-LINK/V2-A.
- LD2 PWR: The red LED indicates that the board is powered.
- User LD3: The orange LED is a user LED connected to the I/O PD13 of the STM32F407VGT6.
- User LD4: The green LED is a user LED connected to the I/O PD12 of the STM32F407VGT6.
- User LD5: The red LED is a user LED connected to the I/O PD14 of the STM32F407VGT6.
- User LD6: The blue LED is a user LED connected to the I/O PD15 of the STM32F407VGT6.
- USB LD7: The green LED indicates when  $V_{BUS}$  is present on CN5 and is connected to PA9 of the STM32F407VGT6.
- USB LD8: The red LED indicates an over-current from  $V_{BUS}$  of CN5 and is connected to the I/O PD5 of the STM32F407VGT6.

## 7.6 Push-buttons

- B1 USER: The user and wake-up buttons are connected to the I/O PA0 of the STM32F407VG.
- B2 RESET: The push-button connected to NRST is used to RESET the STM32F407VG.

## 7.7 On-board audio capability

The STM32F407VG microcontroller uses an audio DAC to output sounds through the audio mini-jack connector.

The STM32F407VG microcontroller controls the audio DAC through the I<sup>2</sup>C interface and processes digital signals through an I<sup>2</sup>S connection or an analog input signal.

- The sound can come independently from different inputs:
  - MEMS microphone: digital using PDM protocol or analog when using the low pass filter
  - USB connector: from external mass storage such as a USB key, USB HDD and others
  - Internal memory of the STM32F407VG microcontroller
- The sound can be output in different ways through the audio DAC:
  - Using I<sup>2</sup>S protocol
  - Using DAC to analog input IN1x of the audio DAC
  - Using the microphone output directly via a low-pass filter to analog input IN2x of the audio DAC

## 7.8 USB OTG supported

The STM32F407VG microcontroller is used on this board to only drive the USB full-speed OTG. The USB Micro-AB connector (CN5) allows the user to connect a host or device component, such as a USB key, mouse, or others.

Two LEDs are dedicated to this module:

- LD7 (green LED) indicates when  $V_{BUS}$  is active.
- LD8 (red LED) indicates an over-current from the connected device.

## 7.9 Motion sensor

The MEMS motion sensor is an ultra-compact low-power three-axis linear accelerometer.

The motion sensor includes a sensing element and an IC interface able to provide the measured acceleration to the external world through the I<sup>2</sup>C/SPI serial interfaces.

The STM32F407VG microcontroller controls this motion sensor through the SPI interface.

## 7.10 JP1 (Idd)

Jumper JP1, labeled Idd, allows the consumption of STM32F407VG to be measured by removing the jumper and connecting an ammeter.

- Jumper on: STM32F407VGT6 is powered (default).
- Jumper off: an ammeter must be connected to measure the STM32F407VG current, (if there is no ammeter, the STM32F407VG is not powered).

## 7.11 Clock sources

### 7.11.1 OSC clock supply

If PH0 and PH1 are used as GPIOs instead of being used as a clock, then SB13 and SB14 are ON and R24, R25 and R68 are OFF.

- **MCO from ST-LINK.** From MCO of the STM32F103. This frequency cannot be changed, it is fixed at 8 MHz and connected to PH0-OSC\_IN of the STM32F407VG. Configuration needed:
  - SB13, SB14, and R25<sup>(a)</sup> OFF
  - R68<sup>(a)</sup> ON
- **Oscillator on board.** From X2 crystal. For typical frequencies, capacitors, and resistors, refer to the STM32F407VG datasheet at [www.st.com](http://www.st.com). Configuration needed:
  - SB13, SB14, and R68<sup>(a)</sup> OFF
  - R25<sup>(a)</sup> ON
- **Oscillator from external PH0.** From the external oscillator through pin 7 of the P2 connector. Configuration needed:
  - SB13 and SB14 ON
  - R25 and R68 OFF

### 7.11.2 OSC 32 KHz clock supply

If PC14 and PC15 are only used as GPIOs and not as a clock, then SB15 and SB16 are ON, and R21 and R22 are OFF.

- **Oscillator on board.** From X1 crystal (not provided). Configuration needed:
  - SB15 and SB16 OFF
  - C16, C27, R21, and R22 ON
- **Oscillator from external PC14.** From the external oscillator through the pin 9 of P2 connector. Configuration needed:
  - SB15 and SB 16 ON
  - R21 and R22 OFF

---

a. As the frequency supplied by X2 is the same as MCO (8 MHz), R25 and R68 are ON.

## 7.12 Solder bridges

**Table 6. Solder bridges**

Bridge	State <sup>(1)</sup>	Description
SB13,14 (X2 crystal) <sup>(2)</sup>	<b>OFF</b>	X2, C14, C15, R24, and R25 provide a clock. PH0 and PH1 are disconnected from P2.
	ON	PH0 and PH1 are connected to P2. R24, R25, and R68 must be OFF.
SB3, 5, 7, 9 (Default)	<b>ON</b>	Reserved, do not modify.
SB2, 4, 6, 8 (Reserved)	<b>OFF</b>	Reserved, do not modify.
SB15,16 (X3 crystal)	<b>ON</b>	PC14 and PC15 are only connected to P2. Remove only R21, R22
	OFF	X3, C16, C27, R21, and R22 deliver a 32 KHz clock. PC14 and PC15 are not connected to P2.
SB1 (B2-RESET)	<b>ON</b>	B2 pushbutton is connected to the NRST pin of the STM32F407VGT6.
	OFF	B2 pushbutton is not connected to the NRST pin of the STM32F407VGT6.
SB20 (B1-USER)	<b>ON</b>	B1 pushbutton is connected to PA0.
	OFF	B1 pushbutton is not connected to PA0.
SB17 (VDD powered from 3V)	<b>OFF</b>	VDD is not powered from 3V, depends on the JP1 jumper.
	ON	VDD is permanently powered from 3V, JP1 jumper has no effect.
SB11 (NRST)	<b>ON</b>	NRST signal of the CN2 connector is connected to the NRST pin of the STM32F407VGT6.
	OFF	NRST signal of the CN2 connector is not connected to the NRST pin of the STM32F407VGT6.
SB12 (SWO)	<b>ON</b>	SWO signal of the CN2 connector is connected to PB3.
	OFF	SWO signal is not connected.
SB10 (STM_RST)	<b>OFF</b>	No incidence on STM32F103C8T6 (ST-LINK/V2-A) NRST signal.
	ON	STM32F103C8T6 (ST-LINK/V2-A) NRST signal is connected to GND.
SB18 (BOOT0)	<b>ON</b>	BOOT0 signal of the STM32F407VGT6 is held low through a 510-ohm pull-down resistor.
	OFF	BOOT0 signal of the STM32F407VGT6 is held high through a 10-kohm pull-up resistor <sup>(3)</sup> .
SB19 (BOOT1)	<b>OFF</b>	The BOOT1 signal of the STM32F407VGT6 is held high through a 10-kohm pull-up resistor.
	ON	The BOOT1 signal of the STM32F407VGT6 is held low through a 510-ohm pull-down resistor.

1. Default SBx state is shown in bold.
2. SB13 and SB14 are OFF to allow the user to choose between MCO and X2 crystal for the clock source.
3. For MB997 C-01 and D-01 revisions, R31 (10-kohm resistor) must be ON before to get such a behavior.

## 7.13 Extension connectors

The male headers P1 and P2 can connect the STM32F4DISCOVERY to a standard prototyping/wrapping board. The STM32F407VG GPIOs are available on these connectors. P1 and P2 can also be probed by an oscilloscope, a logical analyzer, or a voltmeter.



Table 7. STM32 pin description versus board functions

STM32 pin			Board function													
Main function	Alternate functions	LQFP 100	Audio DAC	Audio sensor	Motion sensor	Push button	LED	SWD	USB	OSC	Free I/O	Power supply	CN5	CN2	P1	P2
BOOT0	V <sub>PP</sub>	94	-	-	-	-	-	-	-	-	-	-	-	-	-	21
NRST	-	14	-	-	-	RESET	-	NRST	-	-	-	-	-	5	6	-
PA0-WKUP	USART2_CTS/USART4_TX/ ETH_MII_CRX/TIM2_CH1_ETR/ TIM5_CH1/TIM8_ETR/ ADC123_IN0/WKUP	23	-	-	-	USER	-	-	-	-	PA0	-	-	-	12	-
PA1	USART2_RTS/USART4_RX/ ETH_RMII_REF_CLK/ ETH_MII_RX_CLK/TIM5_CH2/ TIM2_CH2/ADC123_IN1	24	-	-	-	-	-	-	-	-	PA1	-	-	-	11	-
PA2	USART2_TX/TIM5_CH3/TIM9_CH1/ TIM2_CH3/ETH_MDIO/ ADC123_IN2	25	-	-	-	-	-	-	-	-	PA2	-	-	-	14	-
PA3	USART2_RX/TIM5_CH4/TIM9_CH2/ TIM2_CH4/OTG_HS_ULPI_D0/ ETH_MII_COL/ADC123_IN3	26	-	-	-	-	-	-	-	-	PA3	-	-	-	13	-
PA4	SPI1_NSS/SPI3_NSS/USART2_CK/ DCMI_HSYNC/OTG_HS_SOF/ I2S3_WS/ADC12_IN4/DAC1_OUT	29	LRCK/ AIN1x	-	-	-	-	-	-	-	-	-	-	-	16	-
PA5	SPI1_SCK/OTG_HS_ULPI_CK/ TIM2_CH1_ETR/TIM8_CHIN/ ADC12_IN5/DAC2_OUT	30	-	-	SCL/ SPC	-	-	-	-	-	-	-	-	-	15	-
PA6	SPI1_MISO/TIM8_BKIN/ TIM13_CH1/DCMI_PIXCLK/ TIM3_CH1/TIM1_BKIN/ADC12_IN6	31	-	-	SDO	-	-	-	-	-	-	-	-	-	18	-
PA7	SPI1_MOSI/TIM8_CH1N/ TIM14_CH1/TIM3_CH2/ ETH_MII_RX_DV/TIM1_CH1N/ RMII_CRX_DV/ADC12_IN7	32	-	-	SDA/SDI /SDO	-	-	-	-	-	-	-	-	-	17	-
PA8	MCO1/USART1_CK/TIM1_CH1/ I2C3_SCL/OTG_FS_SOF	67	-	-	-	-	-	-	-	-	PA8	-	-	-	-	43
PA9	USART1_TX/TIM1_CH2/ I2C3_SMBA/DCMI_D0/ OTG_FS_VBUS	68	-	-	-	-	GREEN	-	V <sub>BUS</sub>	-	-	-	1	-	-	44
PA10	USART1_RX/TIM1_CH3/ OTG_FS_ID/DCMI_D1	69	-	-	-	-	-	-	ID	-	-	-	4	-	-	41



**Table 7. STM32 pin description versus board functions (continued)**

STM32 pin			Board function													
Main function	Alternate functions	LQFP 100	Audio DAC	Audio sensor	Motion sensor	Push button	LED	SWD	USB	OSC	Free I/O	Power supply	CN5	CN2	P1	P2
PA11	USART1_CTS/CAN1_RX/ TIM1_CH4/OTG_FS_DM	70	-	-	-	-	-	-	DM	-	-	-	2	-	-	-
PA12	USART1_RTS/CAN1_TX/ TIM1_ETR/OTG_FS_DP	71	-	-	-	-	-	-	DP	-	-	-	3	-	-	-
PA13	JTMS-SWDIO	72	-	-	-	-	-	SWDIO	-	-	-	-	-	4	-	42
PA14	JTCK-SWCLK	76	-	-	-	-	-	SWCLK	-	-	-	-	-	2	-	39
PA15	JTDI/SPI3_NSS/I2S3_WS/ TIM2_CH1_ETR/SPI1_NSS	77	-	-	-	-	-	-	-	-	PA15	-	-	-	-	40
PB0	TIM3_CH3/TIM8_CH2N/ OTG_HS_ULPI_D1/ETH_MII_RXD2/ TIM1_CH2N/ADC12_IN8	35	-	-	-	-	-	-	-	-	PB0	-	-	-	22	-
PB1	TIM3_CH4/TIM8_CH3N/ OTG_HS_ULPI_D2/ETH_MII_RXD3/ OTG_HS_INTN/TIM1_CH3N/ ADC12_IN9	36	-	-	-	-	-	-	-	-	PB1	-	-	-	21	-
PB2	BOOT1	37	-	-	-	-	-	-	-	-	-	-	-	-	24	-
PB3	JTDO/TRACESWO/SPI3_SCK/ I2S3_CK/TIM2_CH2/SPI1_SCK	89	-	-	-	-	-	SWO	-	-	PB3	-	-	6	-	28
PB4	NJTRST/SPI3_MISO/TIM3_CH1/ SPI1_MISO/I2S3ext_SD	90	-	-	-	-	-	-	-	-	PB4	-	-	-	-	25
PB5	I2C1_SMBA/CAN2_RX/ OTG_HS_ULPI_D7/ETH_PPS_OUT/ TIM3_CH2/SPI1_MOSI/SPI3_MOSI/ DCMI_D10/I2S3_SD	91	-	-	-	-	-	-	-	-	PB5	-	-	-	-	26
PB6	I2C1_SCL/TIM4_CH1/CAN2_TX/ OTG_FS_INTN/DCMI_D5/ USART1_TX	92	SCL	-	-	-	-	-	-	-	-	-	-	-	-	23
PB7	I2C1_SDA/FSMC_NL/ DCMI_VSYNC/USART1_RX/ TIM4_CH2	93	-	-	-	-	-	-	-	-	PB7	-	-	-	-	24
PB8	TIM4_CH3/SDIO_D4/TIM10_CH1/ DCMI_D6/OTG_FS_SCL/ ETH_MII_TXD3/I2C1_SCL/ CAN1_RX	95	-	-	-	-	-	-	-	-	PB8	-	-	-	-	19



Table 7. STM32 pin description versus board functions (continued)

STM32 pin			Board function													
Main function	Alternate functions	LQFP 100	Audio DAC	Audio sensor	Motion sensor	Push button	LED	SWD	USB	OSC	Free I/O	Power supply	CN5	CN2	P1	P2
PB9	SPI2_NSS/I2S2_WS/TIM4_CH4/ TIM11_CH1/OTG_FS_SDA/ SDIO_D5/DCMI_D7/I2C1_SDA/ CAN1_TX	96	SDA	-	-	-	-	-	-	-	-	-	-	-	-	20
PB10	SPI2_SCK/I2S2_CK/I2C2_SCL/ USART3_TX/OTG_HS_ULPI_D3/ ETH_MII_RX_ER/OTG_HS_SCL/ TIM2_CH3	47	-	CLK	-	-	-	-	-	-	-	-	-	-	34	-
PB11	I2C2_SDA/USART3_RX/ OTG_HS_ULPI_D4/ ETH_RMII_TX_EN/ETH_MII_TX_EN/ OTG_HS_SDA/TIM2_CH4	48	-	-	-	-	-	-	-	-	PB11	-	-	-	35	-
PB12	SPI2_NSS/I2S2_WS/I2C2_SMBA/ USART3_CK/TIM1_BKIN/CAN2_RX/ OTG_HS_ULPI_D5/ ETH_RMII_TXD0/ETH_MII_TXD0/ OTG_HS_ID	51	-	-	-	-	-	-	-	-	PB12	-	-	-	36	-
PB13	SPI2_SCK/I2S2_CK/USART3_CTS/ TIM1_CH1N/CAN2_TX/ OTG_HS_ULPI_D6/ ETH_RMII_TXD1/ETH_MII_TXD1/ OTG_HS_VBUS	52	-	-	-	-	-	-	-	-	PB13	-	-	-	37	-
PB14	SPI2_MISO/TIM1_CH2N/ TIM12_CH1/OTG_HS_D/ USART3_RTS/TIM8_CH2N/ I2S2ext_SD	53	-	-	-	-	-	-	-	-	PB14	-	-	-	38	-
PB15	SPI2_MOSI/I2S2_SD/TIM1_CH3N/ TIM8_CH3N/TIM12_CH2/ OTG_HS_DP	54	-	-	-	-	-	-	-	-	PB15	-	-	-	39	-
PC0	OTG_HS_ULPI_STP/ADC123_IN10	15	-	-	-	-	-	-	Power On	-	-	-	-	-	8	-
PC1	ETH_MDC/ADC123_IN11	16	-	-	-	-	-	-	-	-	PC1	-	-	-	7	-
PC2	SPI2_MISO/OTG_HS_ULPI_DIR/ TH_MII_TXD2/I2S2ext_SD/ ADC123_IN12	17	-	-	-	-	-	-	-	-	PC2	-	-	-	10	-
PC3	SPI2_MOSI/I2S2_SD/ OTG_HS_ULPI_NXT/ ETH_MII_TX_CLK/ADC123_IN13	18	-	DOUT/A IN4x	-	-	-	-	-	-	-	-	-	-	9	-



**Table 7. STM32 pin description versus board functions (continued)**

STM32 pin			Board function													
Main function	Alternate functions	LQFP 100	Audio DAC	Audio sensor	Motion sensor	Push button	LED	SWD	USB	OSC	Free I/O	Power supply	CN5	CN2	P1	P2
PC4	ETH_RMII_RX_D0/ ETH_MII_RX_D0/ADC12_IN14	33	-	-	-	-	-	-	-	-	PC4	-	-	-	20	-
PC5	ETH_RMII_RX_D1/ ETH_MII_RX_D1/ADC12_IN15	34	-	-	-	-	-	-	-	-	PC5	-	-	-	19	-
PC6	I2S2_MCK/TIM8_CH1/SDIO_D6/ USART6_TX/DCMI_D0/TIM3_CH1	63	-	-	-	-	-	-	-	-	PC6	-	-	-	-	47
PC7	I2S3_MCK/TIM8_CH2/SDIO_D7/ USART6_RX/DCMI_D1/TIM3_CH2	64	MCLK	-	-	-	-	-	-	-	-	-	-	-	-	48
PC8	TIM8_CH3/SDIO_D0/TIM3_CH3/ USART6_CK/DCMI_D2	65	-	-	-	-	-	-	-	-	PC8	-	-	-	-	45
PC9	I2S_CKIN/MCO2/TIM8_CH4/ SDIO_D1/I2C3_SDA/DCMI_D3/ TIM3_CH4	66	-	-	-	-	-	-	-	-	PC9	-	-	-	-	46
PC10	SPI3_SCK/I2S3_CK/UART4_TX/ SDIO_D2/DCMI_D8/USART3_TX	78	SCLK	-	-	-	-	-	-	-	-	-	-	-	-	37
PC11	UART4_RX/SPI3_MISO/SDIO_D3/ DCMI_D4/USART3_RX/ I2S3ext_SD	79	-	-	-	-	-	-	-	-	PC11	-	-	-	-	38
PC12	UART5_TX/SDIO_CK/DCMI_D9/ SPI3_MOSI/I2S3_SD/USART3_CK	80	SDIN	-	-	-	-	-	-	-	-	-	-	-	-	35
PC13	RTC_AF1	7	-	-	-	-	-	-	-	-	PC13	-	-	-	-	12
PC14	OSC32_IN	8	-	-	-	-	-	-	-	OSC32_IN	PC14	-	-	-	-	9
PC15	OSC32_OUT	9	-	-	-	-	-	-	-	OSC32_OUT	PC15	-	-	-	-	10
PD0	FSMC_D2/CAN1_RX	81	-	-	-	-	-	-	-	-	PD0	-	-	-	-	36
PD1	FSMC_D3/CAN1_TX	82	-	-	-	-	-	-	-	-	PD1	-	-	-	-	33
PD2	TIM3_ETR/UART5_RX/SDIO_CMD /DCMI_D11	83	-	-	-	-	-	-	-	-	PD2	-	-	-	-	34
PD3	FSMC_CLK/USART2_CTS	84	-	-	-	-	-	-	-	-	PD3	-	-	-	-	31
PD4	FSMC_NOE/USART2_RTS	85	RESET	-	-	-	-	-	-	-	-	-	-	-	-	32
PD5	FSMC_NWE/USART2_TX	86	-	-	-	-	RED	-	Over current	-	-	-	-	-	-	29



Table 7. STM32 pin description versus board functions (continued)

STM32 pin			Board function													
Main function	Alternate functions	LQFP 100	Audio DAC	Audio sensor	Motion sensor	Push button	LED	SWD	USB	OSC	Free I/O	Power supply	CN5	CN2	P1	P2
PD6	FSMC_NWAIT/USART2_RX	87	-	-	-	-	-	-	-	-	PD6	-	-	-	-	30
PD7	USART2_CK/FSMC_NE1/ FSMC_NCE2	88	-	-	-	-	-	-	-	-	PD7	-	-	-	-	27
PD8	FSMC_D13/USART3_TX	55	-	-	-	-	-	-	-	-	PD8	-	-	-	40	-
PD9	FSMC_D14/USART3_RX	56	-	-	-	-	-	-	-	-	PD9	-	-	-	41	-
PD10	FSMC_D15/USART3_CK	57	-	-	-	-	-	-	-	-	PD10	-	-	-	42	-
PD11	FSMC_A16/USART3_CTS	58	-	-	-	-	-	-	-	-	PD11	-	-	-	43	-
PD12	FSMC_A17/TIM4_CH1/ USART3_RTS	59	-	-	-	-	GREEN	-	-	-	-	-	-	-	44	-
PD13	FSMC_A18/TIM4_CH2	60	-	-	-	-	ORANGE	-	-	-	-	-	-	-	45	-
PD14	FSMC_D0/TIM4_CH3	61	-	-	-	-	RED	-	-	-	-	-	-	-	46	-
PD15	FSMC_D1/TIM4_CH4	62	-	-	-	-	BLUE	-	-	-	-	-	-	-	47	-
PE0	TIM4_ETR/FSMC_NBL0/DCMI_D2	97	-	-	INT1	-	-	-	-	-	-	-	-	-	-	17
PE1	FSMC_NBL1/DCMI_D3	98	-	-	INT2	-	-	-	-	-	-	-	-	-	-	18
PE2	TRACECLK/FSMC_A23/ ETH_MII_TXD3	1	-	-	-	-	-	-	-	-	PE2	-	-	-	-	15
PE3	TRACED0/FSMC_A19	2	-	-	CS_I2C/SPI	-	-	-	-	-	-	-	-	-	-	16
PE4	TRACED1/FSMC_A20/DCMI_D4	3	-	-	-	-	-	-	-	-	PE4	-	-	-	-	13
PE5	TRACED2/FSMC_A21/TIM9_CH1/ DCMI_D6	4	-	-	-	-	-	-	-	-	PE5	-	-	-	-	14
PE6	TRACED3/FSMC_A22/TIM9_CH2/ DCMI_D7	5	-	-	-	-	-	-	-	-	PE6	-	-	-	-	11
PE7	FSMC_D4/TIM1_ETR	38	-	-	-	-	-	-	-	-	PE7	-	-	-	25	-
PE8	FSMC_D5/TIM1_CH1N	39	-	-	-	-	-	-	-	-	PE8	-	-	-	26	-
PE9	FSMC_D6/TIM1_CH1	40	-	-	-	-	-	-	-	-	PE9	-	-	-	27	-
PE10	FSMC_D7/TIM1_CH2N	41	-	-	-	-	-	-	-	-	PE10	-	-	-	28	-
PE11	FSMC_D8/TIM1_CH2	42	-	-	-	-	-	-	-	-	PE11	-	-	-	29	-
PE12	FSMC_D9/TIM1_CH3N	43	-	-	-	-	-	-	-	-	PE12	-	-	-	30	-
PE13	FSMC_D10/TIM1_CH3	44	-	-	-	-	-	-	-	-	PE13	-	-	-	31	-



**Table 7. STM32 pin description versus board functions (continued)**

STM32 pin			Board function													
Main function	Alternate functions	LQFP 100	Audio DAC	Audio sensor	Motion sensor	Push button	LED	SWD	USB	OSC	Free I/O	Power supply	CN5	CN2	P1	P2
PE14	FSMC_D11/TIM1_CH4	45	-	-	-	-	-	-	-	-	PE14	-	-	-	32	-
PE15	FSMC_D12/TIM1_BKIN	46	-	-	-	-	-	-	-	-	PE15	-	-	-	33	-
PH0	OSC_IN	12	-	-	-	-	-	-	-	OSC_IN	PH0	-	-	-	-	7
PH1	OSC_OUT	13	-	-	-	-	-	-	-	OSC_OUT	PH1	-	-	-	-	8
-	-	-	-	-	-	-	-	-	-	-	-	5V	-	-	-	3
-	-	-	-	-	-	-	-	-	-	-	-	5V	-	-	-	4
-	-	-	-	-	-	-	-	-	-	-	-	3V	-	-	-	5
-	-	-	-	-	-	-	-	-	-	-	-	3V	-	-	-	6
-	-	-	-	-	-	-	-	-	-	-	-	VDD	-	-	3	-
-	-	-	-	-	-	-	-	-	-	-	-	VDD	-	-	4	-
-	-	-	-	-	-	-	-	-	-	-	-	VDD	-	-	-	22
-	-	-	-	-	-	-	-	GND	GND	-	-	GND	5	3	1	-
-	-	-	-	-	-	-	-	-	-	-	-	GND	-	-	2	-
-	-	-	-	-	-	-	-	-	-	-	-	GND	-	-	5	-
-	-	-	-	-	-	-	-	-	-	-	-	GND	-	-	23	-
-	-	-	-	-	-	-	-	-	-	-	-	GND	-	-	49	-
-	-	-	-	-	-	-	-	-	-	-	-	GND	-	-	50	-
-	-	-	-	-	-	-	-	-	-	-	-	GND	-	-	-	1
-	-	-	-	-	-	-	-	-	-	-	-	GND	-	-	-	2
-	-	-	-	-	-	-	-	-	-	-	-	GND	-	-	-	49
-	-	-	-	-	-	-	-	-	-	-	-	GND	-	-	-	50

## 8 STM32F4DISCOVERY Discovery kit information

### 8.1 Product marking

The product and each board composing the product are identified with one or several stickers. The stickers, located on the top or bottom side of each PCB, provide product information:

- Main board featuring the target device: product order code, product identification, serial number, and board reference with revision.  
Single-sticker example:

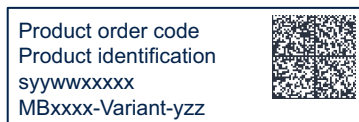

Dual-sticker example:



- Other boards if any: board reference with revision and serial number.  
Examples:



On the main board sticker, the first line provides the product order code, and the second line the product identification.

On all board stickers, the line formatted as “*MBxxxx-Variant-yzz*” shows the board reference “*MBxxxx*”, the mounting variant “*VARIANT*” when several exist (optional), the PCB revision “*y*”, and the assembly revision “*zz*”, for example B01. The other line shows the board serial number used for traceability.

Products and parts labeled as “*ES*” or “*E*” are not yet qualified or feature devices that are not yet qualified. STMicroelectronics disclaims any responsibility for consequences arising from their use. Under no circumstances will STMicroelectronics be liable for the customer's use of these engineering samples. Before deciding to use these engineering samples for qualification activities, contact STMicroelectronics' quality department.

“*ES*” or “*E*” marking examples of location:

- On the targeted STM32 that is soldered on the board (for an illustration of STM32 marking, refer to the STM32 datasheet *Package information* paragraph at the [www.st.com](http://www.st.com) website).
- Next to the evaluation tool ordering part number that is stuck or silk-screen printed on the board.

Some boards feature a specific STM32 device version, which allows the operation of any bundled commercial stack/library available. This STM32 device shows a “*U*” marking option at the end of the standard part number and is not available for sales.

To use the same commercial stack in their applications, the developers might need to purchase a part number specific to this stack/library. The price of those part numbers includes the stack/library royalties.

## 8.2 STM32F4DISCOVERY product history

Table 8. Product history

Order code	Product identification	Product details	Product change description	Product limitations
STM32F4DISCOVERY	STM32F4DISCOVER/01-0	MCU: – STM32F407VGT6 silicon revision 'A'	Initial revision	No limitation
		MCU errata sheet: – <i>STM32F405/407xx and STM32F415/417xx device errata</i> (ES0182)		
		Board: – MB997-F407VGT6-B01 (main board)		
	STM32F4DISCOVER/02-0	MCU: – STM32F407VGT6 silicon revision 'Z'	– MCU silicon revision changed – Board revision changed	No limitation
		MCU errata sheet: – <i>STM32F405/407xx and STM32F415/417xx device errata</i> (ES0182)		
		Board: – MB997-F407VGT6-B02 (main board)		
	STM32F4DISCOVER/03-0 STM32F4DISCOVER/04-0 STM32F4DISC-FAR/04-0	MCU: – STM32F407VGT6 silicon revision 'Z' or silicon revision 'Y'	Board revision changed	No limitation
		MCU errata sheet: – <i>STM32F405/407xx and STM32F415/417xx device errata</i> (ES0182)		
		Board: – MB997-F407VGT6-C01 (main board)		

Table 8. Product history (continued)

Order code	Product identification	Product details	Product change description	Product limitations
STM32F407G-DISC1	32F407GDISC1/01-0 32F407GDISC1-RS/01-0 32F407GDISC1-FA/01-0	MCU: – STM32F407VGT6 silicon revision 'Y'	Board revision changed	No limitation
		MCU errata sheet: – <i>STM32F405/407xx and STM32F415/417xx device errata</i> (ES0182)		
		Board: – MB997-F407VGT6-D01 (main board)		
	DK32F407G\$CW1 DK32F407G\$CW2	MCU: – STM32F407VGT6 silicon revision 'Y'	– Board revision changed – Packaging: plastic blister replaced by a carton box	No limitation
MCU errata sheet: – <i>STM32F405/407xx and STM32F415/417xx device errata</i> (ES0182)				
Board: – MB997-F407VGT6-E01 (main board)				
DK32F407G\$RW1	MCU: – STM32F407VGT6 silicon revision '5' or '6'	– Board revision changed – Board sticker format changed – MCU silicon revision changed	No limitation	
	MCU errata sheet: – <i>STM32F405/407xx and STM32F415/417xx device errata</i> (ES0182)			
	Board: – MB997-F407VGT6-E01 (main board)			
DK32F407G\$RW2	MCU: – STM32F407VGT6 silicon revision '5' or '6'	Board revision changed	No limitation	
	MCU errata sheet: – <i>STM32F405/407xx and STM32F415/417xx device errata</i> (ES0182)			
	Board: – MB997-F407VGT6-G01 (main board)			

## 8.3 Board revision history

**Table 9. Board revision history**

Board reference	Board variant and revision	Board change description	Board limitations
MB997 (main board)	F407VGT6-B01	Initial revision	No limitation
	F407VGT6-B02	<ul style="list-style-type: none"> <li>– R27 OFF</li> <li>– R28 ON</li> </ul>	No limitation
	F407VGT6-C01	<ul style="list-style-type: none"> <li>– LIS302 replaced by 9177973 LIS3DSHTR</li> <li>– R31 OFF</li> <li>– STM32F4 VSS replaces PDR_ON</li> </ul>	No limitation
	F407VGT6-D01	<ul style="list-style-type: none"> <li>– PCB silkscreen changed to STM32F407G-DISC1</li> <li>– Mbed-enabled removed on silkscreen</li> <li>– STM32F103C8T6 replaced by STM32F103CBT6</li> <li>– ST-LINK/V2 is replaced by ST-LINK/V2-A</li> </ul>	No limitation
	F407VGT6-E01	<ul style="list-style-type: none"> <li>– Microphone MEMS MP45DT02-M replaced by IMP34DT05TR</li> <li>– Update Certification logos on PCB</li> <li>– Some LED references changed</li> </ul>	No limitation
	F407VGT6-G01	<ul style="list-style-type: none"> <li>– Several part references updated due to obsolescence:               <ul style="list-style-type: none"> <li>- U7 Stereo Codec CIRRUS LOGIC CS43L22-CNZ replaced by CIRRUS LOGIC WM8904CGEFL/RV with impact on the PCB and firmware</li> <li>- ESD protection STMICROELECTRONICS EMIF02-USB03F2 replaced by STMICROELECTRONICS ECMF2-40A100N6, STMICROELECTRONICS ESDA7P120-1U1M, and STMICROELECTRONICS ESDZV5H-1BU2 with impact on the PCB.</li> <li>- U5 MEMS sensor STMICROELECTRONICS LIS3DSHTR replaced by STMICROELECTRONICS IIS2DLPC with impact on the firmware</li> </ul> </li> <li>– Refer to the bill of materials for further details</li> </ul>	No limitation

## 9 Compliance statements and conformity declarations

### 9.1 Federal Communications Commission (FCC) compliance statement

#### Part 15.19

This device complies with Part 15 of the FCC Rules. Operation is subject to the following two conditions: (1) this device may not cause harmful interference, and (2) this device must accept any interference received, including interference that may cause undesired operation.

#### Part 15.21

Any changes or modifications to this equipment not expressly approved by STMicroelectronics may cause harmful interference and void the user's authority to operate this equipment.

#### Part 15.105

This equipment has been tested and found to comply with the limits for a Class B digital device, pursuant to part 15 of the FCC Rules. These limits are designed to provide reasonable protection against harmful interference in a residential installation. This equipment generates uses and can radiate radio frequency energy and, if not installed and used in accordance with the instructions, may cause harmful interference to radio communications. However, there is no guarantee that interference will not occur in a particular installation. If this equipment does cause harmful interference to radio or television reception which can be determined by turning the equipment off and on, the user is encouraged to try to correct interference by one or more of the following measures:

- Reorient or relocate the receiving antenna.
- Increase the separation between the equipment and receiver.
- Connect the equipment into an outlet on a circuit different from that to which the receiver is connected.
- Consult the dealer or an experienced radio/TV technician for help.

*Note: Use only shielded cables..*

#### Responsible party (in the USA)

Francesco Doddo  
STMicroelectronics, Inc.  
200 Summit Drive | Suite 405 | Burlington, MA 01803  
USA  
Telephone: +1 781-472-9634

## 9.2 Innovation, Science and Economic Development Canada (ISED) compliance statement

Innovation, Science and Economic Development Canada  
(ISED) compliance statement

**This product complies with the ICES-003 standard class B of the ISED regulation.**

ISED Canada ICES-003 Compliance Label: CAN ICES-3 (B)/NMB-3 (B).

*Note: Use only shielded cables.*

**Ce produit est conforme à la norme NMB-003 classe B de la ISDE.**

Étiquette de conformité à la NMB-003 d'ISDE Canada : CAN ICES-3 (B) / NMB-3 (B).

*Note: Utiliser uniquement des câbles blindés.*

## 9.3 UKCA conformity

### Simplified UK declaration of conformity

Hereby, the manufacturer STMicroelectronics, declares that the equipment type STM32F4DISCOVERY is in compliance with the UK Electromagnetic Compatibility Regulations 2016 (UK SI 2016 No. 1091) and with the Restriction of the Use of Certain Hazardous Substances in Electrical and Electronic Equipment Regulations 2012 (UK SI 2012 No. 3032).

*Note: Use only shielded cables.*

## 9.4 CE conformity

### 9.4.1 Simplified EU declaration of conformity

Hereby, STMicroelectronics declares that the equipment type STM32F4DISCOVERY is in compliance with directives 2011/53/EU and 2015/863/EU (RoHS), and 2014/30/EU (EMC).

*Note:*

- RoHS: Restriction of hazardous substances
- EMC: Electromagnetic compatibility

*Note: Use only shielded cables.*

### 9.4.2 Déclaration de conformité UE simplifiée

STMicroelectronics déclare que l'équipement électrique du type STM32F4DISCOVERY est conforme aux directives 2011/53/UE et 2015/863/UE (LdSD), et à la directive 2014/30/UE (CEM).

*Note:*

- LdSD : directive sur la limitation de l'utilisation des substances dangereuses
- CEM : compatibilité électromagnétique

*Note: Utiliser uniquement des câbles blindés.*

## 10 Product disposal

### Disposal of this product: WEEE (Waste Electrical and Electronic Equipment)

(Applicable in Europe)

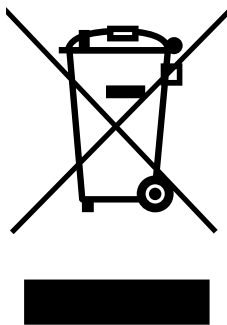

This symbol on the product, accessories, or accompanying documents indicates that the product and its electronic accessories must not be disposed of with household waste at the end of their working life.

To prevent possible harm to the environment and human health from uncontrolled waste disposal, separate these items from other types of waste and recycle them responsibly at a designated collection point to promote the sustainable reuse of material resources.

#### Household users:

Contact the retailer that you purchased the product from or your local authority for details of your nearest designated collection point.

#### Business users:

Contact your dealer or supplier for further information.

# 11 Revision history

**Table 10. Document revision history**

Date	Revision	Changes
27-Sept-2011	1	Initial release.
30-Jan-2012	2	Added Section 5.1: STM32F407VGT6 microcontroller corrected <i>Figure 3</i> MCU name, modified <i>Figure 2</i> and <i>Section 7: Electrical schematics</i> . Modified <a href="#">Table 7</a> PE2 and PE3 entries.
28-Nov-2013	3	Updated for board rev. C. Modified title. Modified <i>Section 6.7: Motion sensor</i> . Updated <i>Section 7: Electrical schematics</i> .
29-Jan-2014	4	Modified <i>Section 6: Hardware and layout</i> , <i>Figure 2</i> , <i>Section 6.7: Motion sensor</i> and <i>Table 6</i> adding MEMS reference.
04-Feb-2016	5	Updated revision to introduce STM32F407G-DISC1 additional order code that corresponds to the mbed-enabled Discovery kit. Updated <i>Introduction</i> , <i>Features</i> , <i>Section 5: Quick start</i> , <i>Section 6: Hardware and layout</i> , <i>Section 6.1: Embedded ST-LINK/V2 (or V2-A)</i> , <i>Section 7: Electrical schematics</i> . Removed <i>Section 4.1 STM32F407VG microcontroller</i> .
31-May-2017	6	Updated <i>Table 6: STM32 pin description versus board functions</i> .
12-Oct-2020	7	Removed all references to the obsolete STM32F4DISCOVERY order code and focused the ST-LINK descriptions on ST-LINK/V2-A accordingly across the document. Removed all mentions of Arm® Mbed™. Removed MEMS product references across the document. Removed <i>Electrical schematics</i> . Updated SB15/SB16 in <i>Table 6</i> , and PA1 and PB14 in <i>Table 7</i> . Reorganized the entire document: <ul style="list-style-type: none"> <li>– Updated <i>Features</i>, <i>Ordering information</i>, and <i>Product marking</i></li> <li>– Added <i>Codification</i> and <i>Development environment</i></li> <li>– Added <i>STM32F4DISCOVERY Discovery kit information</i></li> <li>– Added <i>Federal Communications Commission (FCC) and ISED Canada Compliance Statements</i></li> </ul>

Table 10. Document revision history (continued)

Date	Revision	Changes
26-May-2025	8	Added: – <a href="#">Section 5: Safety recommendations</a> – Note to <a href="#">Table 6: Solder bridges</a> regarding R31 setting on MB997 specific versions – <a href="#">Section 10: Product disposal</a> Updated: – <a href="#">Section 3.4: EDA resources</a> – <a href="#">Section 8: STM32F4DISCOVERY Discovery kit information</a> including <a href="#">Product marking</a> , <a href="#">Product history</a> , and <a href="#">Board revision history</a> – <a href="#">Section Note:: Utiliser uniquement des câbles blindés.</a>
27-Feb-2026	9	Updated: – <a href="#">Section 5: Safety recommendations</a> – <a href="#">Section 7.4: Power supply and power selection</a> – <a href="#">Section 7.7: On-board audio capability</a> – <a href="#">Section 8.2: STM32F4DISCOVERY product history</a> – <a href="#">Section 8.3: Board revision history</a> – <a href="#">Section 9: Compliance statements and conformity declarations</a> – <a href="#">Section 10: Product disposal</a>

**IMPORTANT NOTICE – READ CAREFULLY**

STMicroelectronics NV and its subsidiaries (“ST”) reserve the right to make changes, corrections, enhancements, modifications, and improvements to ST products and/or to this document at any time without notice.

In the event of any conflict between the provisions of this document and the provisions of any contractual arrangement in force between the purchasers and ST, the provisions of such contractual arrangement shall prevail.

The purchasers should obtain the latest relevant information on ST products before placing orders. ST products are sold pursuant to ST’s terms and conditions of sale in place at the time of order acknowledgment.

The purchasers are solely responsible for the choice, selection, and use of ST products and ST assumes no liability for application assistance or the design of the purchasers’ products.

No license, express or implied, to any intellectual property right is granted by ST herein.

Resale of ST products with provisions different from the information set forth herein shall void any warranty granted by ST for such product.

If the purchasers identify an ST product that meets their functional and performance requirements but that is not designated for the purchasers’ market segment, the purchasers shall contact ST for more information.

ST and the ST logo are trademarks of ST. For additional information about ST trademarks, refer to [www.st.com/trademarks](http://www.st.com/trademarks). All other product or service names are the property of their respective owners.

Information in this document supersedes and replaces information previously supplied in any prior versions of this document.

© 2026 STMicroelectronics – All rights reserved