

Introduction

The 32L496GDISCOVERY Discovery kit is a complete demonstration and development platform for the STMicroelectronics Arm® Cortex®-M4 core-based STM32L496AGI6 microcontroller. Thanks to the innovative ultra-low-power-oriented features, extended RAM, and graphics performance (Chrom-ART Accelerator™) offered by the STM32L496AG, the 32L496GDISCOVERY kit is designed to enable easy prototyping for many applications, including audio and graphics, with state-of-the-art energy efficiency. For even more user-friendliness, the on-board ST-LINK/V2-1 debugger provides out-of-the-box loading and debugging capabilities. The microcontroller features the following interfaces: four I²Cs, three SPIs, one SDIO, FMC, and Quad-SPI. It also features five USARTs, one ULP UART, two CAN buses, three 12-bit ADCs, two 12-bit DACs, two SAIs, two ULP analog comparators, two OPAMPs, LCD 8 × 40 or 4 × 44 with step-up converter, four digital filters for sigma-delta modulator and SWP, 8- to 14-bit camera interface, USB 2.0 OTG FS, and JTAG and SWD debugging support. This 32L496GDISCOVERY Discovery kit offers everything required for users to get started quickly and develop applications easily.

The full range of hardware features on the board helps users evaluate almost all peripherals (USB OTG FS, microSD™ card, 8-bit camera, 8-Mbit PSRAM, IDD measurement, full-duplex I²S with an audio CODEC and stereo jack for headset including analog microphone, DFSDM with a pair of MEMS digital microphones on board, Quad-SPI flash memory device, 1.54-inch TFT LCD using FMC interface with capacitive touch panel and others) and develop applications. ARDUINO® Uno V3, Pmod™; and STMod+ connectors allow easy connection of extension shields or daughterboards for specific applications.

The integrated ST-LINK/V2-1 provides an embedded in-circuit debugger and programmer for the STM32 MCU.

The 32L496GDISCOVERY Discovery kit comes with the STM32 comprehensive software HAL library and LL APIs together with various packaged software examples.

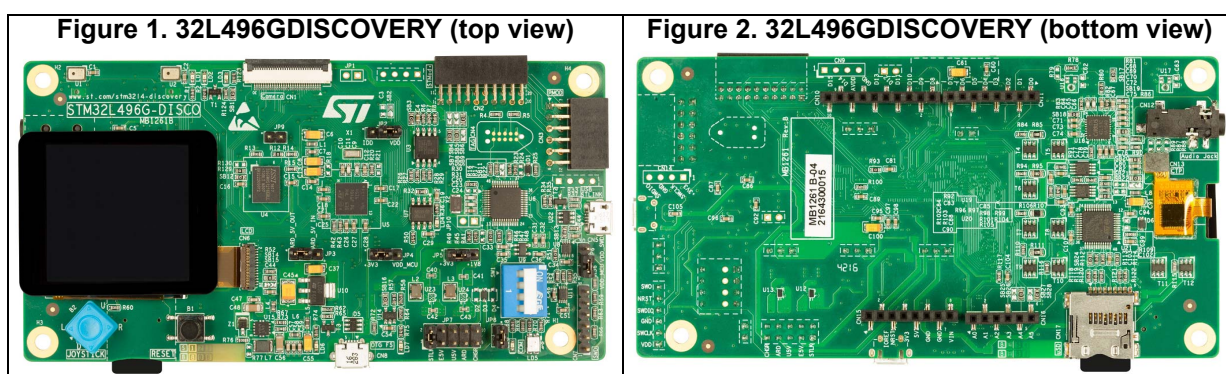

1. Pictures are not contractual.

Contents

- 1 Features 7**
- 2 Ordering information 8**
 - 2.1 Codification 8
- 3 Development environment 9**
 - 3.1 System requirements 9
 - 3.2 Development toolchains 9
 - 3.3 CAD resources 9
- 4 Conventions 9**
- 5 Safety recommendations 10**
 - 5.1 Targeted audience 10
 - 5.2 Handling the board 10
- 6 Hardware layout and configuration 11**
 - 6.1 32L496GDISCOVERY Discovery kit layout 12
 - 6.2 32L496GDISCOVERY Discovery kit mechanical drawing 14
 - 6.3 Embedded ST-LINK/V2-1 15
 - 6.3.1 Drivers 15
 - 6.3.2 ST-LINK/V2-1 firmware upgrade 16
 - 6.4 Low-power consumption state 16
 - 6.5 TAG and SWD 16
 - 6.6 Power supply 17
 - 6.6.1 Supplying the board with the ST-LINK/V2-1 USB connector (CN5) ... 17
 - 6.6.2 Supplying the board with VIN from the ARDUINO® connector (CN15) . 18
 - 6.6.3 Supplying the board with the USB OTG FS connector (CN8) 18
 - 6.6.4 Supplying the board with +5V of the ARDUINO® connector (CN15) ... 19
 - 6.6.5 Supplying the board with a charger connected to ST-LINK 19
 - 6.6.6 MCU power supply options 20
 - 6.6.7 Supplying the board with ST-LINK/V2-1 USB 20
 - 6.6.8 Measurement of current consumption by the microcontroller 20

6.7	Programming/debugging when the power supply is not from ST-LINK/V2-1	22
6.8	Clock source	22
6.9	Reset sources	22
6.10	Boot configuration	22
6.11	Audio codec	23
6.12	Stereo headset and headphone jack	23
6.13	DFSDM	23
6.14	USB OTG FS	23
6.14.1	32L496GDISCOVERY as USB Device	23
6.14.2	32L496GDISCOVERY as USB Host	24
6.15	PSRAM memory	24
6.16	Quad-SPI flash memory	24
6.17	Virtual COM port	24
6.18	Joystick and LEDs	24
7	Connectors	26
7.1	ARDUINO® Uno V3 compatible connectors	26
7.2	CN3 Pmod™ connector	28
7.3	CN2 STMod+ connector	28
7.4	CN4 TAG connector	29
7.5	CN7 SWD connector	30
7.6	CN8 USB OTG FS Micro-AB connector	30
7.7	CN1 camera module connector	30
7.8	microSD™ card	31
7.9	LCD	32
7.10	Backlight	34
7.11	Touch panel	34
7.12	CN5 ST-LINK/V2-1 USB Micro-B connector	34
8	32L496GDISCOVERY board I/O assignment	36
9	Pmod™ and STMod+ schematic table	40
10	Fanout board	42

10.1	MikroElektronika mikroBUS™ compatible connector (Fanout CN10 and CN11)	42
11	32L496GDISCOVERY board information	44
11.1	Product marking	44
11.2	32L496GDISCOVERY product history	45
11.3	Board revision history	46
12	Federal Communications Commission (FCC) and ISED Canada Compliance Statements	47
12.1	FCC Compliance Statement	47
12.2	ISED Compliance Statement	48
13	CE conformity	49
13.1	Warning	49
14	Product disposal	50
	Revision history	51

List of tables

Table 1.	Ordering Information	8
Table 2.	Codification explanation	8
Table 3.	ON/OFF conventions	9
Table 4.	JP6 (VDD_STL) jumper description	17
Table 5.	32L496GDISCOVERY board power configuration	17
Table 6.	JP7 (STLK) jumper description	18
Table 7.	JP7 (E5V) jumper description	18
Table 8.	JP7 (U5V) jumper description	18
Table 9.	JP7 (ARD) jumper description	19
Table 10.	JP7 (CHGR) jumper description	20
Table 11.	IDD measurement jumper settings	21
Table 12.	32L496GDISCOVERY user LEDs	25
Table 13.	32L496GDISCOVERY non-user LEDs	25
Table 14.	JP4 (VDDA) jumper description	26
Table 15.	ARDUINO® compatible connectors	27
Table 16.	CN3 Pmod™ connector	28
Table 17.	CN2 STMod+ connector	28
Table 18.	CN4 TAG connector	29
Table 19.	CN7 SWD connector	30
Table 20.	CN8 USB OTG FS Micro-AB connector	30
Table 21.	CN1 camera module connector	31
Table 22.	CN17 microSD™ card connector	32
Table 23.	CN6 LCD connector	33
Table 24.	CN13 touch panel connector	34
Table 25.	CN5 USB Micro-B connector	35
Table 26.	32L496GDISCOVERY Discovery board I/O assignment	36
Table 27.	STMod+ connector signals	41
Table 28.	Description of the mikroBUS™ connector pins	43
Table 29.	Product history	45
Table 30.	Board revision history	46
Table 31.	Document revision history	51

List of figures

Figure 1.	32L496GDISCOVERY (top view)	1
Figure 2.	32L496GDISCOVERY (bottom view)	1
Figure 3.	Hardware block diagram	11
Figure 4.	32L496GDISCOVERY top layout	12
Figure 5.	32L496GDISCOVERY bottom layout	13
Figure 6.	32L496GDISCOVERY mechanical drawing (bottom view)	14
Figure 7.	USB composite device	15
Figure 8.	CN4 TAG connector (Top view)	29
Figure 9.	CN68 USB OTG FS Micro-AB connector (Front view)	30
Figure 10.	CN1 camera module connector (Front view)	31
Figure 11.	CN17 microSD™ card connector (Top view)	32
Figure 12.	CN5 USB Micro-B connector (Front view)	34
Figure 13.	STMod+ Fanout module plugged into CN2 connector	42

1 Features

- STM32L496AGI6 Arm^{®(a)} Cortex[®]-M4 core-based microcontroller featuring 1 Mbyte of flash memory and 320 Kbytes of RAM in a UFBGA169 package
- 1.54-inch 240 x 240-pixel TFT color LCD with parallel interface
- SAI audio codec, with stereo output, including analog microphone input
- Stereo digital MEMS microphones
- 8-Mbit PSRAM
- 64-Mbit Quad-SPI flash
- Eight LEDs including three user-controllable ones
- Reset push-button
- 4-way joystick with selection
- Board connectors:
 - 8-bit camera
 - Stereo headset jack
 - microSD[™] card holder with included card
 - USB Micro-B
 - USB Micro-AB
 - STMod+ and Pmod[™]
 - ARDUINO[®] Uno V3
- On-board ST-LINK/V2-1 debugger/programmer with USB re-enumeration capability: mass storage, Virtual COM port, and debug port
- Flexible power-supply options: ST-LINK USB V_{BUS}, USB OTG FS connector, or external sources
- 1.8 and 3.3 V possible MCU supply voltages
- IDD measurement
- Comprehensive free software libraries and examples available with the STM32Cube MCU Package
- Support of a wide choice of Integrated Development Environments (IDEs) including IAR Embedded Workbench[®], MDK-ARM, and STM32CubeIDE



a. Arm is a registered trademark of Arm Limited (or its subsidiaries) in the US and/or elsewhere.

2 Ordering information

To order the 32L496GDISCOVERY Discovery kit, refer to [Table 1](#). Additional information is available from the datasheet and reference manual of the target STM32.

Table 1. Ordering Information

Order Code	Board reference	Target STM32
STM32L496G-DISCO	– MB1261 ⁽¹⁾ – MB1280 ⁽²⁾	STM32L496AGI6

1. Main board
2. Fanout board

2.1 Codification

The meaning of the codification is explained in Table 2.

Table 2. Codification explanation

STM32XXYYT-DISCO	Description	Example: STM32L496G-DISCO
XX	MCU series in STM32 32-bit Arm Cortex MCUs	STM32L4 series
YY	MCU product line in the series	STM32L4x6 product line
T	STM32 flash memory size: – G for 1 Mbyte	1 Mbyte
DISCO	Discovery kit	Discovery kit

3 Development environment

3.1 System requirements

- Multi-OS support: Windows® 10, Linux®(a) 64-bit, or macOS®(b)
- USB Type-A or USB Type-C® to Micro-B cable

3.2 Development toolchains

- IAR Systems - IAR Embedded Workbench®(c)
- Keil® MDK-ARM(c) (d)
- STMicroelectronics - STM32CubeIDE

3.3 CAD resources

All board design resources, including schematics, CAD databases, manufacturing files, and the bill of materials, are available from the 32L496GDISCOVERY product page at www.st.com.

4 Conventions

Table 3 defines some conventions used in the present document.

Table 3. ON/OFF conventions

Convention	Definition
Jumper JPx ON	Jumper fitted
Jumper JPx OFF	Jumper not fitted
Jumper JPx [1-2]	Jumper fitted between pin 1 and pin 2
Solder bridge SBx ON	SBx connections closed by 0 Ω resistor
Solder bridge SBx OFF	SBx connections left open
Resistor Rx ON	Resistor soldered
Resistor Rx OFF	Resistor not soldered
Capacitor Cx ON	Capacitor soldered
Capacitor Cx OFF	Capacitor not soldered

a. Linux® is a registered trademark of Linus Torvalds.

b. macOS® is a trademark of Apple Inc., registered in the U.S. and other countries and regions.

c. On Windows® only.

d. All other trademarks are the property of their respective owners.

5 Safety recommendations

5.1 Targeted audience

This product targets users with at least basic electronics or embedded software development knowledge such as engineers, technicians, or students. This board is not a toy and is not suited for use by children.

5.2 Handling the board

This product contains a bare printed circuit board and like all products of this type, the user must be careful about the following points:

- The connection pins on the board might be sharp. Be careful when handling the board to avoid hurting yourself.
- This board contains static-sensitive devices. To avoid damaging it, handle the board in an ESD-proof environment.
- While powered, do not touch the electric connections on the board with your fingers or anything conductive. The board operates at a voltage level that is not dangerous, but components might be damaged when shorted.
- Do not put any liquid on the board and avoid operating the board close to water or at a high humidity level.
- Do not operate the board if dirty or dusty.

6 Hardware layout and configuration

The 32L496GDISCOVERY Discovery kit is designed around the STM32L496AGI6 (169-ball UFBGA package). The hardware block diagram (see [Figure 3](#)) illustrates the connection between STM32L496AGI6 and peripherals (PSRAM, Quad-SPI flash memory, color LCD, USB OTG FS connector, USART, audio, camera connector, IDD measurement, joystick, microSD™ card, ARDUINO® Uno V3, Pmod™ and STMod+ shields, and embedded ST-LINK). [Figure 4](#) and [Figure 5](#) help users locate these features on the 32L496GDISCOVERY board. The mechanical dimensions of the 32L496GDISCOVERY board are shown in [Figure 6](#).

Figure 3. Hardware block diagram

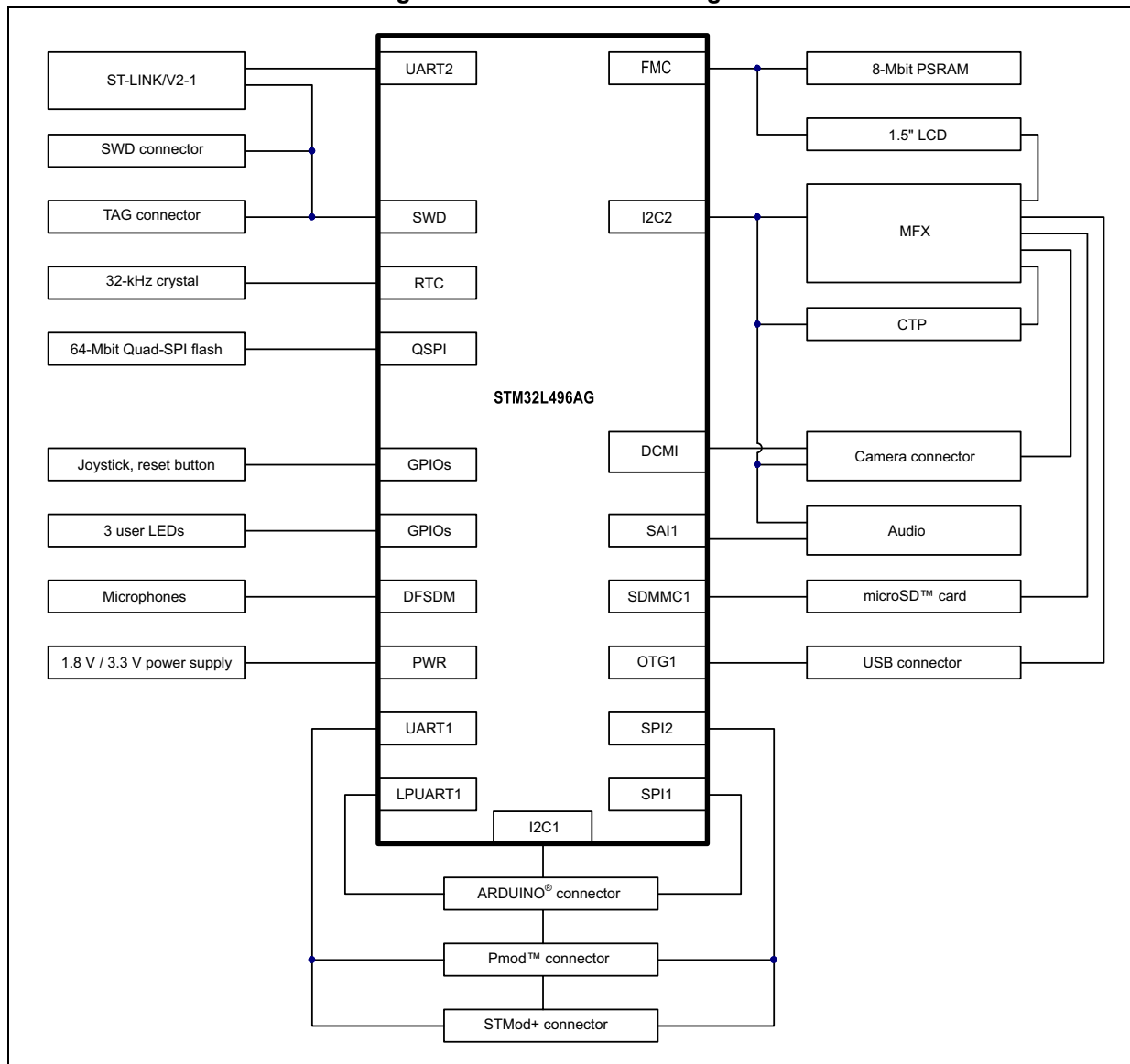

6.1 32L496GDISCOVERY Discovery kit layout

Figure 4. 32L496GDISCOVERY top layout

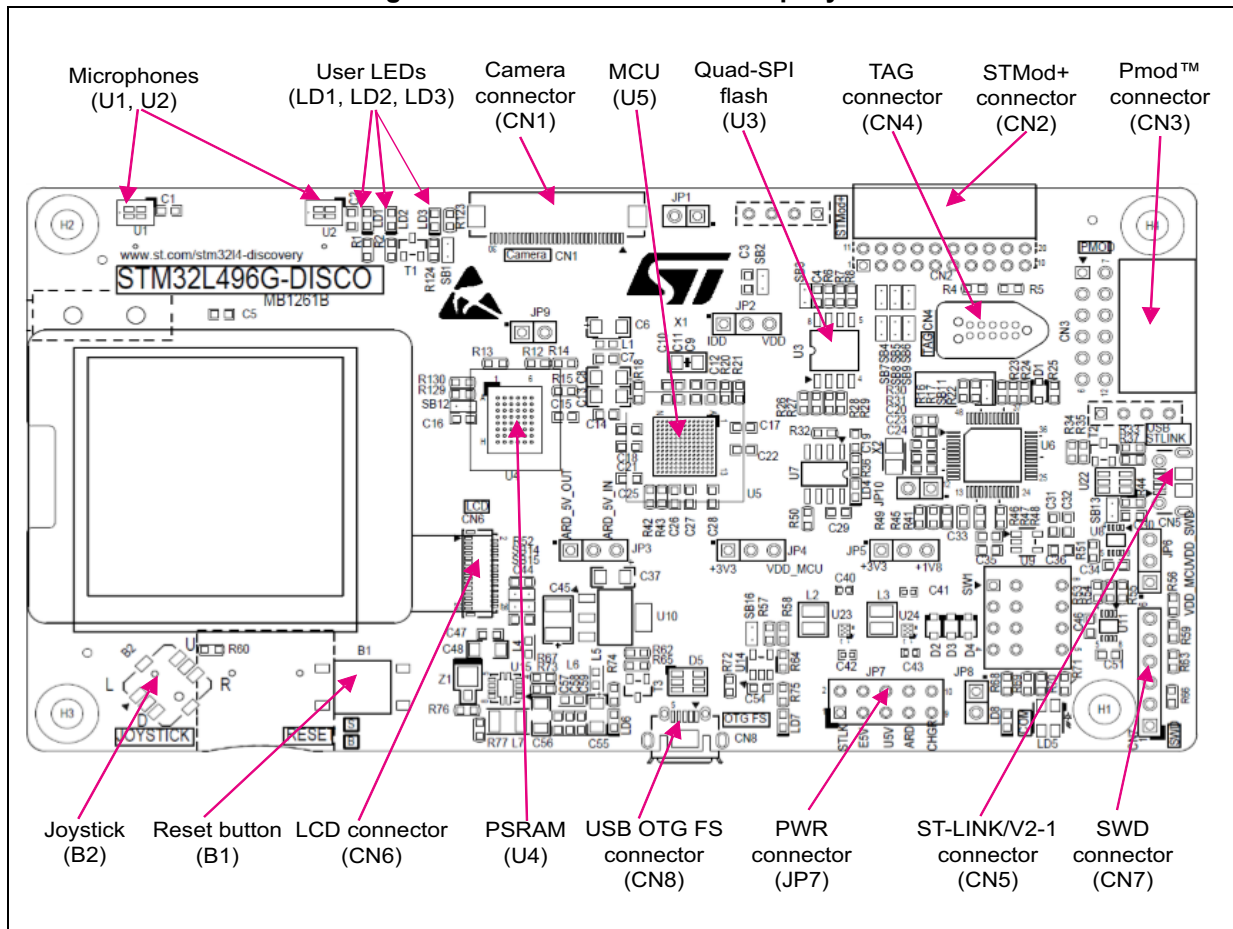
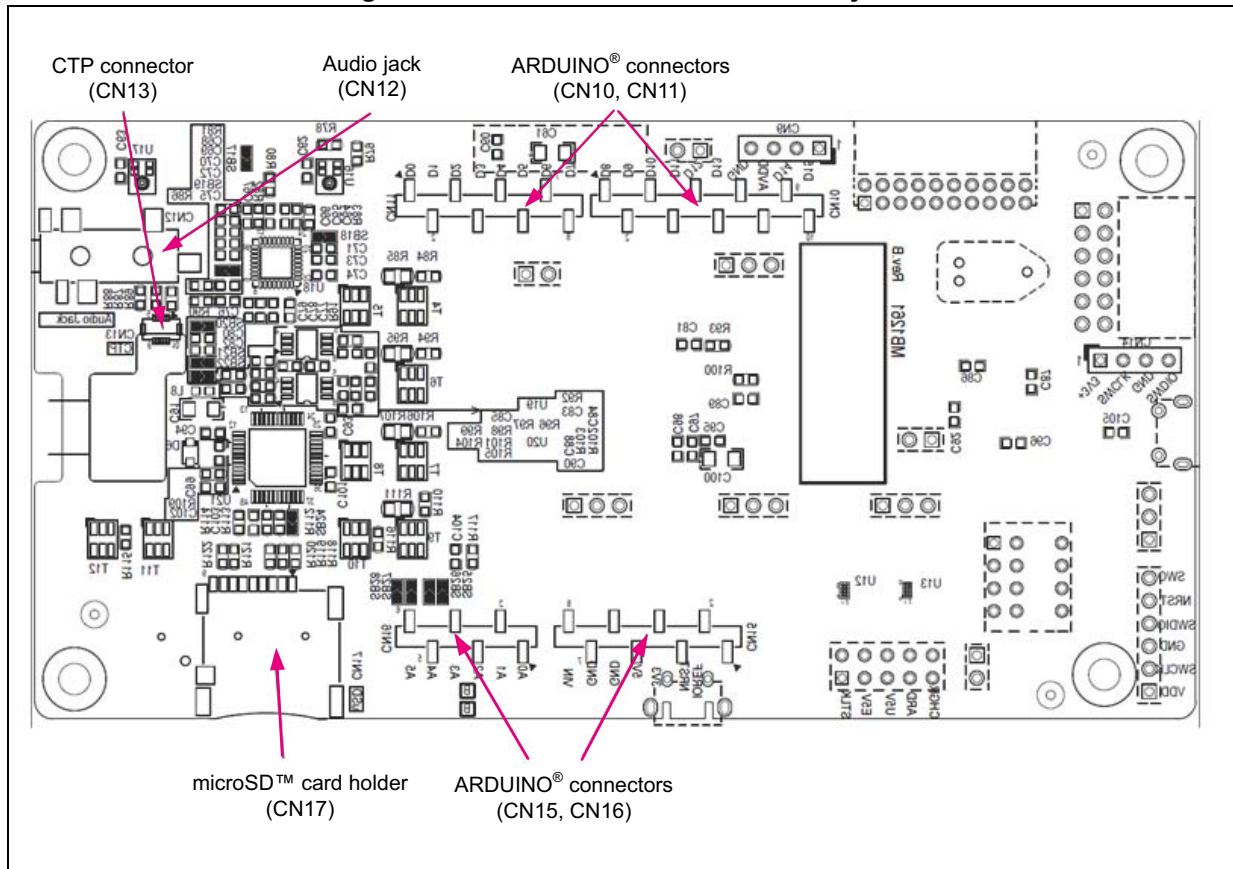
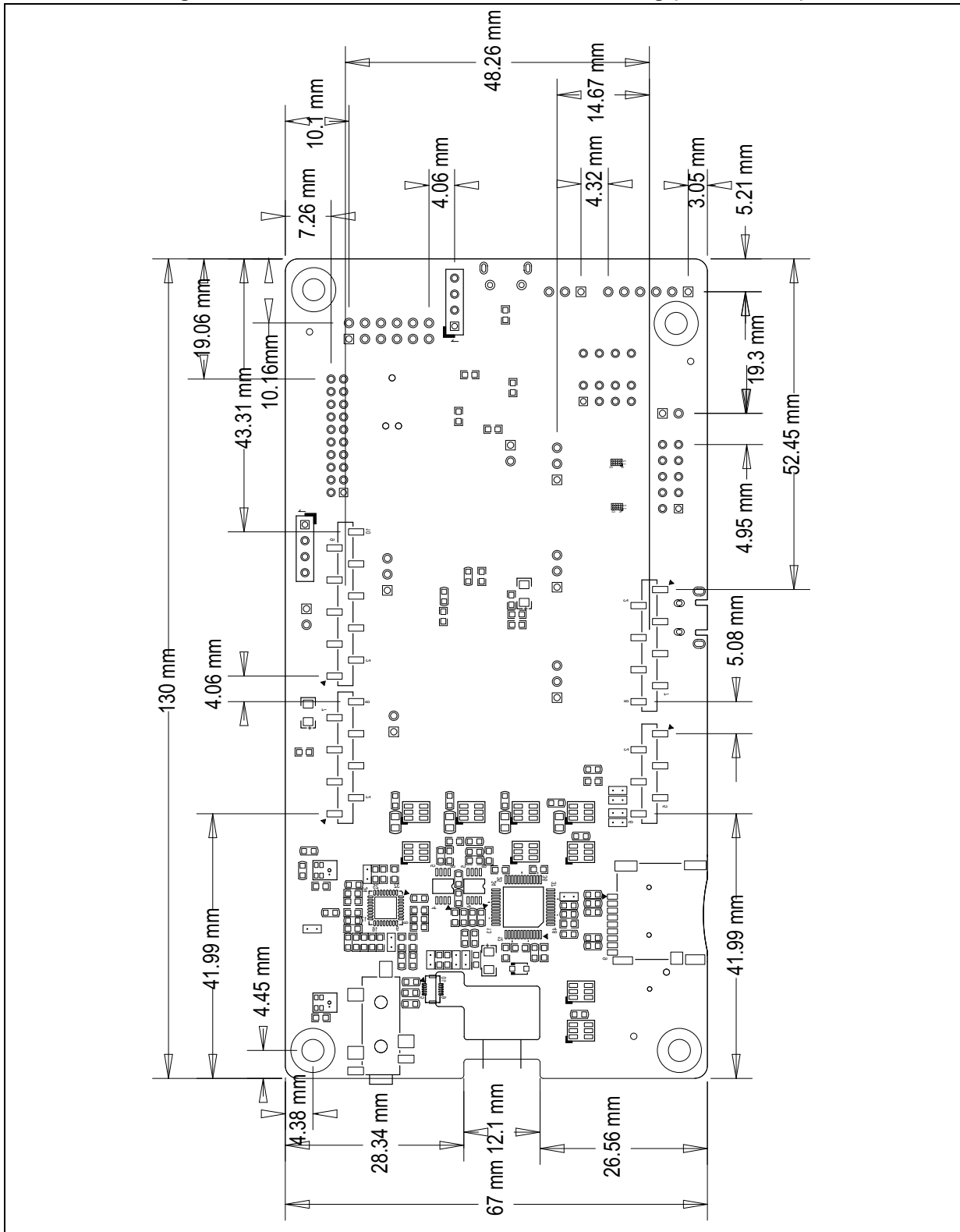

Figure 5. 32L496GDISCOVERY bottom layout



6.2 32L496GDISCOVERY Discovery kit mechanical drawing

Figure 6. 32L496GDISCOVERY mechanical drawing (bottom view)



6.3 Embedded ST-LINK/V2-1

The ST-LINK/V2-1 programming and debugging tool is integrated into the 32L496GDISCOVERY board. Compared to ST-LINK/V2 the changes are listed below.

The new features supported on ST-LINK/V2-1 are:

- USB software re-enumeration
- Virtual COM port interface on USB
- Mass storage interface on USB
- USB power management request for more than 100 mA power on USB

These features are no longer supported on ST-LINK/V2-1:

- SWIM interface
- Application voltage lower than 3 V

For general information concerning the debugging and programming features that are common to both versions V2 and V2-1, refer to *ST-LINK/V2 in-circuit debugger/programmer for STM8 and STM32 user manual* (UM1075).

6.3.1 Drivers

Before connecting the 32L496GDISCOVERY board to a Windows® PC via USB, a driver for ST-LINK/V2-1 must be installed. It can be downloaded from the www.st.com website.

In case the 32L496GDISCOVERY board is connected to the PC before installing the driver, the PC device manager might report some 32L496GDISCOVERY board interfaces as *Unknown*. To recover from this situation, after installing the dedicated driver, the association of *Unknown* USB devices found on the 32L496GDISCOVERY board to this dedicated driver must be manually updated in the device manager.

Note: It is recommended to use the USB Composite Device, as shown in [Figure 7](#).

Figure 7. USB composite device

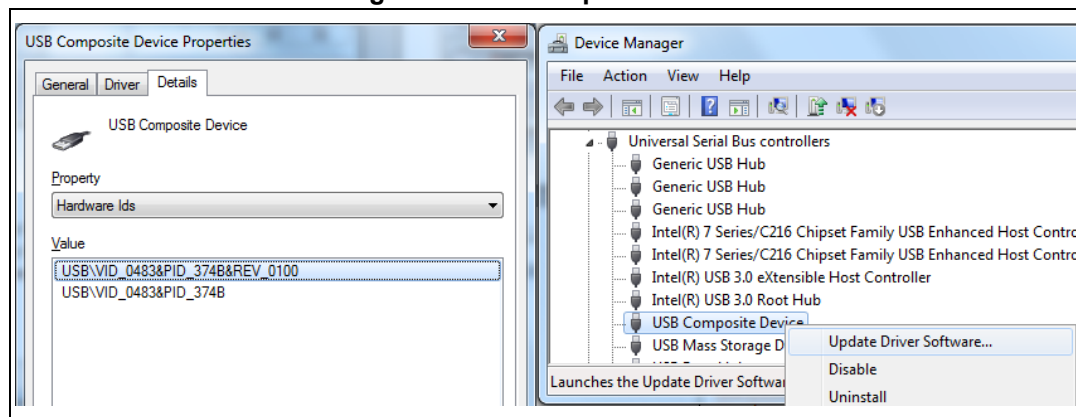

6.3.2 ST-LINK/V2-1 firmware upgrade

The ST-LINK/V2-1 embeds a firmware upgrade mechanism for the in-place upgrade with the USB port. The firmware might evolve during the lifetime of the ST-LINK/V2-1 product with new functionality, bug fixes, or support for new microcontroller families. Therefore, it is recommended to visit the www.st.com website before starting to use the 32L496GDISCOVERY board and periodically, to stay updated with the latest firmware version.

6.4 Low-power consumption state

The 32L496GDISCOVERY board can be set in a low-power state with a maximum current kept below 20 μ A at 5 V.

The low-power mode is reached when the following conditions are satisfied:

1. The connections between the ST-LINK/V2-1 and the MCU are manually disconnected with the microswitch SW1. This especially controls the four pull-ups on RST, the pull-up on SWDIO, and the VDD and 5 V detection circuits.
2. The peripherals (Including LCD, CTP, and PSRAM) are unpowered with the MOSFET controlled by the PH0 signal of STM32L496AGI6.
3. The JP8 jumper is OFF so the 5-V power LED is powered down.
4. Firmware sets the peripherals to reach the Power-down mode
 - a) Set QSPI to low-power mode
 - b) Set MFX to sleep mode
 - c) Remove the microSD™ card from the socket
 - d) Set all the audio lines to low

6.5 TAG and SWD

One TAG interface footprint is reserved on the 32L496GDISCOVERY board. It can be used to debug and program the on-board MCU.

One 6-pin header was added to the 32L496GDISCOVERY board. This header connects to the on-board ST-LINK SWD that can be used to debug and program an external MCU. In such a configuration, the VDD power supply from the external board can be either 1.8 V or 3.3 V thanks to the on-board voltage converter.

[Table 4](#) describes the use of the JP6 jumper for selecting between on-board and external MCU.

Table 4. JP6 (VDD_STL) jumper description

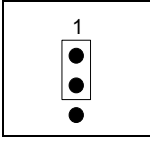
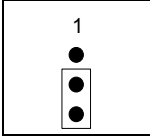
Jumper	Description
JP6 VDD_STL setting	<p>Default setting: VDD_STL gets power from the 32L496GDISCOVERY board. ST-LINK can be used to program the on-board MCU. JP6 is set [1-2]</p> 
	<p>VDD_STL gets externally supplied power with the CN7 connector. ST-LINK can be used to program the external MCU. JP6 is set [2-3].</p> 

6.6 Power supply

The 32L496GDISCOVERY board is designed to be powered by a selection of sources according to the position of the JP7 jumper as described in [Table 5](#).

Table 5. 32L496GDISCOVERY board power configuration

JP7 configuration	Power connector	Power source
STLK	CN5	STLINK/V2-1
E5V	CN15 (VIN)	ARDUINO®
U5V	CN8	USB OTG
ARD	CN15 (5 V)	ARDUINO®
CHGR	CN5	DC power charger

Note: The Discovery board must be powered by a power supply unit or by auxiliary equipment complying with the standard EN-62368-1: 2014/A11:2017, and must be safety extralow voltage (SELV) with limited power capability.

6.6.1 Supplying the board with the ST-LINK/V2-1 USB connector (CN5)

In this mode, STLK from the ST-LINK/V2-1 USB connector (CN5) is used. The corresponding setting is described in [Table 6](#). The green LED (LD8) is lit to confirm the presence of a 5 V supply.

Note: This mode is limited to 500 mA.

Table 6. JP7 (STLK) jumper description

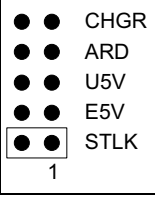
Jumper	Description
JP7 Power source selector	<p>Default setting The 32L496GDISCOVERY board is supplied with the Micro-B ST-LINK/V2-1 connector (CN5). JP7 is set [1-2] on STLK.</p> 

6.6.2 Supplying the board with VIN from the ARDUINO® connector (CN15)

In this mode, 6 V to 9 V DC is supplied with the VIN pin of the ARDUINO® compatible connector (CN15). The corresponding setting is described in [Table 7](#). The green LED (LD8) is lit to confirm the presence of a 5 V supply.

Note: The voltage is limited to 9 V so that the temperature of the regulator (U10) is kept within the safe thermal area.

Table 7. JP7 (E5V) jumper description

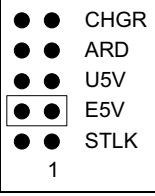
Jumper	Description
JP7 Power source selector	<p>The 32L496GDISCOVERY board is supplied with the VIN pin of the ARDUINO® compatible connector (CN15). JP7 is set [3-4] on E5V.</p> 

6.6.3 Supplying the board with the USB OTG FS connector (CN8)

In this mode, 5 V DC is supplied with the user USB FS connector (CN8). The corresponding setting is described in [Table 8](#). The green LED (LD8) is lit to confirm the presence of a 5 V supply.

Table 8. JP7 (U5V) jumper description

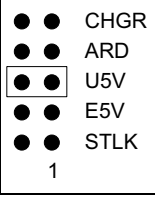
Jumper	Description
JP7 Power source selector	<p>The 32L496GDISCOVERY board is supplied by the USB OTG connector (CN8). JP7 is set [5-6] on U5V.</p> 

6.6.4 Supplying the board with +5V of the ARDUINO® connector (CN15)

In this mode, 5 V DC is supplied with the +5V of the ARDUINO® compatible connector (CN15). The corresponding setting is described in [Table 9](#). The green LED (LD8) is lit to confirm the presence of a 5 V supply.

Note: JP3 is set [2-3] on the input/output voltage selection so that the 32L496GDISCOVERY board is supplied 5 V with the CN15 connector (default setting).

Table 9. JP7 (ARD) jumper description

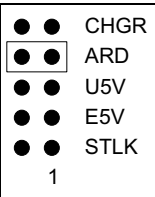
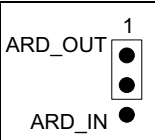
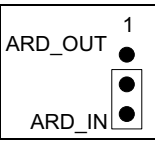
Jumper	Description
<p>JP7 Power source selector</p>	<p>5 V is supplied with +5V of the ARDUINO® compatible connector (CN15). JP7 [7-8] is on ARD.</p> 
<p>JP3 ARD 5V input/output voltage selection</p>	<p>The 32L496GDISCOVERY board supplies 5 V with +5V of the ARDUINO® compatible connector (CN15) to an external board. JP3 is set [1-2] on ARD_OUT.</p> 
	<p>Default setting The 32L496GDISCOVERY board is supplied 5 V with +5V of the ARDUINO® compatible connector (CCN15). JP3 is set [2-3] on ARD_IN.</p> 

6.6.5 Supplying the board with a charger connected to ST-LINK

In this mode, a 5 V-DC power charger is connected to the USB STLINK connector (CN5). The corresponding setting is described in [Table 10](#). The green LED (LD8) is lit to confirm the presence of a 5 V supply.

Note: Debugging is impossible if the 32L496GDISCOVERY board is powered by an external USB charger. This limitation does not apply when power is supplied by a PC.

Warning: In this mode, the 32L496GDISCOVERY board is not protecting a PC supplying power with the CN15 connector against electrical damage.

Table 10. JP7 (CHGR) jumper description

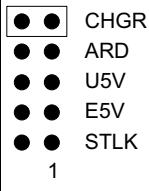
Jumper	Description
<p>JP7 Power source selector</p>	<p>The 32L496GDISCOVERY board is supplied with the CN5 connector. JP7 is set [9-10] on CHGR.</p> 

6.6.6 MCU power supply options

The 32L496GDISCOVERY board offers the possibility to supply the MCU with 1.8 V or 3.3 V. A jumper must be placed at the 1V8 location of JP5 (connecting pins 2 and 3) to supply the MCU with 1.8 V. The jumper must be placed at the 3V3 location of JP5 (connecting pins 1 and 2) to supply the MCU with 3.3 V.

6.6.7 Supplying the board with ST-LINK/V2-1 USB

In this mode, the USB Host (a PC) is connected to the standard Micro-B USB receptacle of the 32L496GDISCOVERY board with a USB cable. The connection event starts the USB enumeration procedure.

In the initial phase of the enumeration procedure, the current supply capability of the host USB port is limited to 100 mA. This value is high enough for normal operation since only the ST-LINK/V2-1 part of 32L496GDISCOVERY draws power during that phase. If the SB11 solder bridge is OFF in the default configuration, the power switch (U7) is set to the OFF position. This isolates the rest of 32L496GDISCOVERY from the power source.

In the next phase of the enumeration procedure, the host PC informs the ST-LINK/V2-1 facility of its capability to supply up to 500 mA. If this is accepted, the ST-LINK/V2-1 sets the power switch to the ON position to supply power to the rest of the 32L496GDISCOVERY board. If the PC USB port is not capable of supplying up to 500 mA, another power source must be used as the VIN pin of the CN15 connector.

If a short circuit occurs on the board, the power switch protects the host USB port against current demand exceeding 600 mA. In such an event, the FAULT red LED (LD4) lights up.

The 32L496GDISCOVERY board can also be supplied power by a USB power source that does not support enumeration, such as a USB charger. In such a particular case, the SB11 solder bridge must be ON. ST-LINK/V2-1 turns the power switch ON regardless of the enumeration procedure result and passes the power unconditionally to the board.



The green LED (LD8) is lit whenever the board is powered.

6.6.8 Measurement of current consumption by the microcontroller

The IDD-labeled JP2 jumper enables an ammeter circuit built into the MCU to measure the STM32L496AGI6's power consumption by directly measuring from 60 nA to 50 mA, or by removing the jumper and connecting an external ammeter.

The MCU must run software to let this current test circuit go into the Low-power mode.

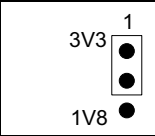
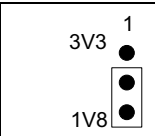
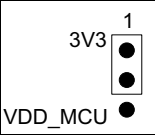
Table 11. IDD measurement jumper settings

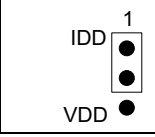
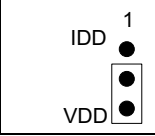
Jumper	Description
JP5 VDD_MCU voltage selection	<p>Default setting The STM32L496AGI6 is supplied with 3.3 V. JP5 is set [1-2] on 3V3.</p> 
	<p>The STM32L496AGI6 is supplied with 1.8 V. JP5 is set [2-3] on 1V8.</p> 
JP4 VDD_USB source selection	<p>Default setting The VDD_USB power pin of the STM32L496AGI6 is supplied with 3.3 V. JP4 is set [1-2] on 3V3.</p> 
	<p>The VDD_USB power pin of the STM32L496AGI6 is supplied with VDD_MCU. JP4 is set [2-3] on VDD_MCU.</p> 
JP2 VDD_MCU measure	<p>Default setting IDD measurement: use of an on-board module that is designed to measure from 60 nA to 50 mA by using several MOSFETs and that automatically switches depending on the range of the measured value.</p> <p>There is no jumper in this configuration: an ammeter must be connected to measure the STM32L496AGI6 current with pins 1 and 2 of JP2. If no ammeter is connected to these pins, the STM32L496AGI6 is unpowered.</p> 
	<p>The STM32L496AGI6 is powered by VDD. JP2 is set [2-3] on VDD.</p> 

6.7 Programming/debugging when the power supply is not from ST-LINK/V2-1

It is mandatory to power the board first using the user USB FS connector (CN8) or the VIN pin of the ARDUINO® connector (CN15) before connecting the USB cable from ST-LINK/V2-1 (CN5) to the PC. Proceeding this way ensures that the enumeration succeeds, thanks to the external power source.

The following power sequence procedure must be respected:

1. Connect the JP7 jumper on U5V pins to use power from the user USB (CN8) or on E5V pins to use power from the VIN pin of the ARDUINO® connector (CN15).
2. Connect the corresponding external power source
3. Check that the green LED (LD8) is turned ON
4. Connect the PC to the ST-LINK/V2-1 USB connector (CN5)

If this order is not respected, the 32L496GDISCOVERY board might be powered by V_{BUS} first from ST-LINK and the following risks might be encountered:

1. If the board needs more than 500 mA current, the PC might be damaged or the PC can limit the current. As a consequence, the board is not powered correctly.
2. 500 mA is requested at enumeration: if the PC cannot provide such current, there is a risk that the request is rejected and that the enumeration does not succeed.

6.8 Clock source

One clock source is available as described below:

- X1, 32-kHz crystal for STM32L496AGI6 embedded RTC

6.9 Reset sources

The reset signal of the 32L496GDISCOVERY board is active at a low level and the reset sources include:

- Reset button (B1)
- ARDUINO® Uno V3 shield board from CN15
- Embedded ST-LINK/V2-1

6.10 Boot configuration

The boot configuration of the STM32L496AGI6 microcontroller is controlled by the BOOT0 signal on pin PH3.

BOOT0 is by default grounded with the R20 pull-down resistor.

It is possible to set BOOT0 high by removing resistor R20 and soldering resistor R21.

6.11 Audio codec

The audio codec (U18) is connected to the SAI1 interface of the STM32L496AGI6. It communicates with STM32L496AGI6 via an I²C bus and offers the possibility to connect stereo headphones or a headset with a mono analog microphone.

The I²C-bus address of the audio codec is 94h.

6.12 Stereo headset and headphone jack

A stereo headphone or a stereo headset with an analog microphone can be plugged into the 3.5 mm standard jack socket (CN12).

If a headset is plugged into CN12, the bias of the microphone is driven by the MICBIAS1 output of the codec, and the analog audio enters the codec by the AIN3A pin.

6.13 DFSDM

Two MEMS digital microphones (U1 and U2) are available on the 32L496GDISCOVERY board. The two microphones are separated by a distance of 21 mm. The microphones are connected to the DFSDM of the STM32L496AGI6 by the PC2 port generating the clock and by the PC7 port collecting the PDM interleaved data. Both are powered by MIC_VDD (PH1 of STM32L496AGI6).

6.14 USB OTG FS

The 32L496GDISCOVERY board supports USB OTG full-speed communication via a USB Micro-AB connector (CN8) and USB power switch (U14) connected to V_{BUS}.

The green LED (LD6) is lit in one of these cases:

- The power switch (U14) is ON and the 32L496GDISCOVERY board works as a USB Host
- V_{BUS} is powered by another USB Host when the 32L496GDISCOVERY board works as a USB Device.

The LD7 red LED is lit in case of overcurrent.

Note 1: When the 32L496GDISCOVERY board is powered by the ST-LINK, then the OTG function provides up to 100 mA.

Note 2: When the 32L496GDISCOVERY board is powered by an external power supply then the OTG function provides more than 100 mA, according to the external power supply capability.

Note 3: When the 32L496GDISCOVERY board is powered by an external power supply with the USB FS connector (CN8) in device mode, do not use a PC as the power source. Refer to [Section 6.6.3](#).

6.14.1 32L496GDISCOVERY as USB Device

When the 32L496GDISCOVERY board is used as a USB Device, the board can be powered by the 5 V DC of the USB OTG FS connection. JP7 is set [5-6].

The VBUS and PWR green LEDs (LD6 and LD8) are lit to confirm the 5 V presence.

6.14.2 32L496GDISCOVERY as USB Host

When the 32L496GDISCOVERY board is used as a USB Host, it supplies the 5 V for the USB peripheral using one of the following sources:

- ST-LINK/V2-1 USB Micro-B connector (CN5) when a jumper connects the pins at the STLK location of the JP7 jumper.
- An external 5 V source connected to pin 5 of the ARDUINO[®] connector (CN15) when a jumper connects the pins at the ARD location of the JP7 jumper.
- An external source between 7 V and 11 V connected to the VIN pin of the ARDUINO[®] connector (CN15) when a jumper connects the pins at the E5V location of JP7.

The LD8 green LED is lit to confirm the presence of the 5 V source.

The MFX_GPIO3 port controls the power switch to deliver the 5 V power to the USB Device connected to the USB connector (CN8). When MFX_GPIO3 is pulled to the ground, the power switch is ON, and the green LED (LD6) confirms the 5 V to the USB device. The LD7 FAULT red LED is lit in case of overcurrent.

For more details, refer to [Section 6.6: Power supply on page 17](#).

6.15 PSRAM memory

An 8-Mbit PSRAM is connected to the NOR_RAM of the FMC interface of the STM32L496AGI6. The data bus is shared with the LCD.

Note: The PSRAM only works when the STM32L496AGI6 is supplied with 3.3 V.

6.16 Quad-SPI flash memory

A 64-Mbit Quad-SPI flash memory device is connected to the Quad-SPI interface of the STM32L496AGI6.

6.17 Virtual COM port

The serial interface USART2 is directly available as a Virtual COM port of the PC connected to the ST-LINK/V2-1 USB connector (CN5). The Virtual COM port settings are 115200 b/s, 8-bit data, no parity, one-stop bit, and no flow control.

6.18 Joystick and LEDs

The blue button (B2) is a four-directional joystick with a selection mode when pressed in the center. The logic state is high when one of the five positions (left, right, up, down, selection) is pressed. The center position is connected to a wake-up pin of the microcontroller PC13. This offers the possibility to wake up the microcontroller by pressing the center of the joystick.

Two LEDs near the camera connector (CN1) are available for the user. Refer to [Figure 4: 32L496GDISCOVERY top layout on page 12](#) for details. The LEDs are LD1 and LD2, from

left to right with the colors orange and green respectively as presented in [Table 13](#). To light a LED, a low logic state 0 must be written in the corresponding GPIO.

Table 12. 32L496GDISCOVERY user LEDs

LED	Control MCU port	Color	Polarity
LD1	MFx_GPIO4	Orange	Active high
LD2	PB13	Green	Active high
LD3	PA5	Green	Active low

Table 13. 32L496GDISCOVERY non-user LEDs

LED	Function
LD4	ST-LINK overcurrent
LD5	ST-LINK
LD6	USB V _{BUS} present
LD7	USB overcurrent
LD8	Board power supply present

7 Connectors

7.1 ARDUINO® Uno V3 compatible connectors

Four female connectors (CN10, CN11, CN15, and CN16) are compatible with ARDUINO® Uno V3 standards. Most shields designed for ARDUINO® Uno V3 are also supported by the 32L496GDISCOVERY board.

The ARDUINO® connectors on the 32L496GDISCOVERY board support the ARDUINO® Uno V3.

There are three possible power sources for VREF+:

- From the 32L496GDISCOVERY board VDDA. The related jumper settings are detailed in [Table 14](#). In this case, a 0 Ω resistor must be mounted on R18.

Table 14. JP4 (VDDA) jumper description

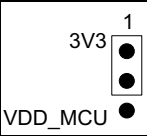
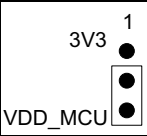
Jumper	Description
JP4 VDDA source selection	<p>Default setting</p> <p>VDDA is supplied from 3.3 V. JP4 [1-2].</p> 
	<p>VDDA is supplied from VDD_MCU. JP4 [2-3].</p> 

Warning: There is a high leakage and a risk of damage in the following configuration: VDDA = VDD_MCU = 1.8 V and 3.3 V connected to ADC input IO.

- From an external shield with the CN10 ARDUINO® connector. In this case, a 0 Ω resistor must be mounted on SB2 and a 100 nF capacitor must be mounted on C3.
- From the STM32L496AGI6 MCU (Default configuration).

Caution: The I/Os of the STM32 microcontroller are 3.3 V compatible instead of 5 V for ARDUINO® Uno V3.

ARDUINO® compatible connectors are detailed in [Table 15](#).

Note 1: The 3.3 V supply on ARD connector PIN4 is not a power input for the 32L496GDISCOVERY board to keep the power architecture simple.

Note 2: The external voltage applied to pin VIN must be in the range of 6 V to 9 V at 25 °C ambient temperature. The regulator (U10) risks overheating and can be damaged if a higher voltage is applied.

Note 3: By default pin 5 and pin 6 of the CN16 connector are connected to MCU ports PC0 and PA1 respectively. The default configuration of solder bridges enables them: SB28 and SB26 are ON, while SB27 and SB25 are OFF. If an I²C interface is needed on pins 5 and 6 of CN16 instead of ADC inputs, SB28 and SB26 must be OFF and SB27 and SB25 must be ON.

7.2 CN3 Pmod™ connector

The standard Pmod™ connector is available on the 32L496GDISCOVERY board to support flexibility in small form factor applications. The Pmod™ connector is implementing Pmod™ types 2A and 4A on the 32L496GDISCOVERY board. The Pmod™ connector is detailed in [Table 16](#).

Table 16. CN3 Pmod™ connector

Pin number	Description	Pin number	Description
1	SS/CTS (PG11)	7	INT (PH2)
2	MOSI/TXD (PB15/PB6)	8	RESET (PB2)
3	MISO/RXD (PI2/PG10)	9	NA
4	SCK/RTS (PI1/PG12)	10	NA
5	GND	11	GND
6	3V3	12	3V3

Refer to [Section 9: Pmod™ and STMod+ schematic table](#) to find more information about Pmod™ pins.

7.3 CN2 STMod+ connector

The STMod+ connector is available on the 32L496GDISCOVERY board to support flexibility in small form factor applications. The STMod+ connector extends the SPI and spare I/Os for a different peripheral expansion. It is described in [Table 17](#).

Table 17. CN2 STMod+ connector

Pin number	Description	Pin number	Description
1	SS/CTS (PG11)	11	INT (PH2)
2	MOSI/TXD (PB15/PB6)	12	RESET (PB2))
3	MISO/RXD (PI2/PG10)	13	ADC (PA4)
4	SCK/RTS (PI1/PG12)	14	PWM (PA0)
5	GND	15	+5V

Table 17. CN2 STMod+ connector (continued)

Pin number	Description	Pin number	Description
6	+5V	16	GND
7	I2C_SCL (PB8)	17	DFSDM-DATA3 (PC7)
8	MOSIs (PI3)	18	DFSDM-CK (PC2)
9	MISOs (PD3)	19	DFSDM-DATA1 (PB12)
10	I2C_SDA (PB7)	20	DFSDM-CK (PC2)

Refer to [Section 9: Pmod™ and STMod+ schematic table](#) to find more information about STMod+ signals.

7.4 CN4 TAG connector

The 10-pin footprint TAG connector supports the SWD mode. It is used to connect to the STM32L496AGI6 for programming or debugging purposes.

Figure 8. CN4 TAG connector (Top view)

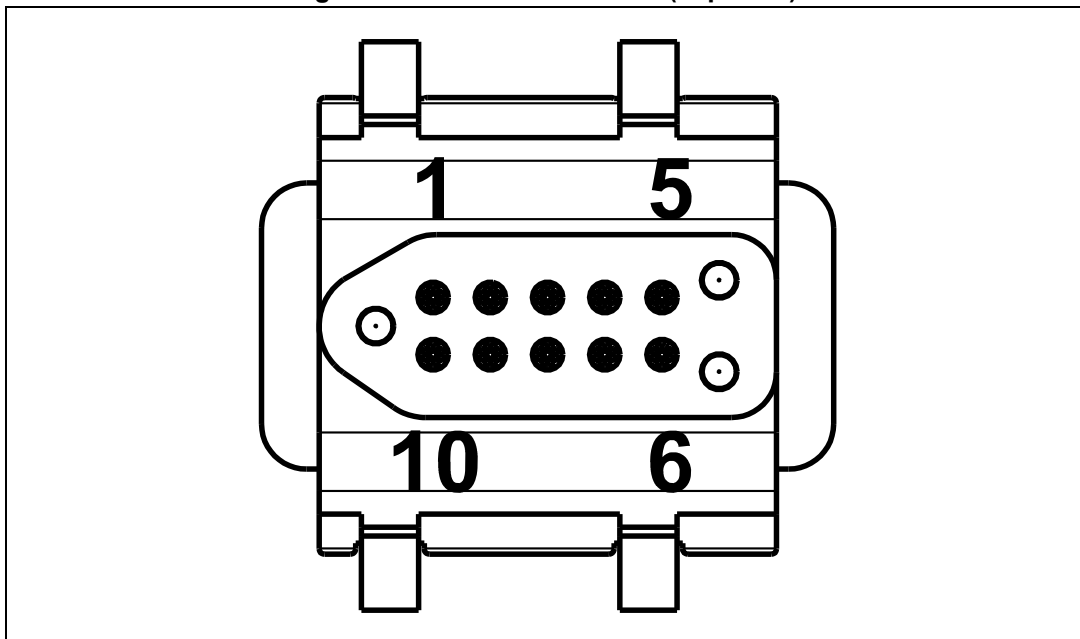

Table 18. CN4 TAG connector

Pin number	Description	Pin number	Description
1	VDD	10	RESET#
2	SWDIO (PA13)	9	NA
3	GND	8	NA
4	SWCLK (PA14)	7	NA
5	GND	6	SWO (PB3)

7.5 CN7 SWD connector

SWD can be used to program or debug on an MCU in an external application board using a cable connected to the CN7 SWD connector with JP6 [2-3].

When SWD is used to program or debug the STM32L496AGI6, JP6 [1-2] (default setting).

Table 19. CN7 SWD connector

Pin number	Description	Pin number	Description
1	VDD	4	SWDIO
2	SWCLK	5	NRST
3	GND	6	SWO

7.6 CN8 USB OTG FS Micro-AB connector

USB OTG full-speed interface is available on 32L496GDISCOVERY as CN8 USB Micro-AB connector.

Figure 9. CN8 USB OTG FS Micro-AB connector (Front view)

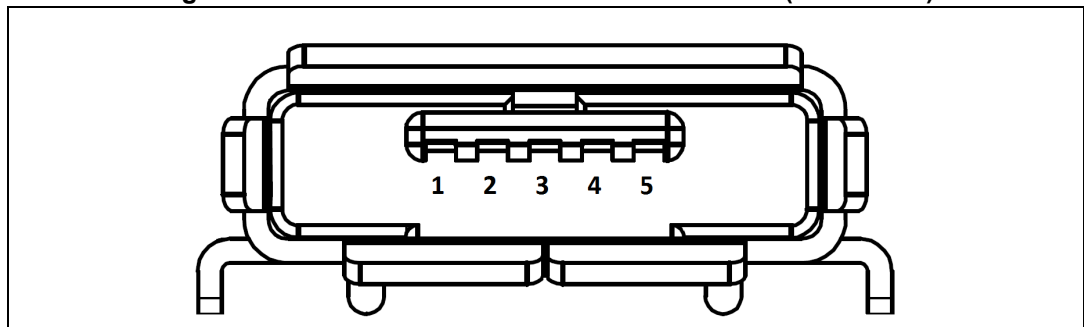

Table 20. CN8 USB OTG FS Micro-AB connector

Pin number	Description	Pin number	Description
1	V _{BUS} (PA9)	4	ID (PA10)
2	DM (PA11)	5	GND
3	DP (PA12)	-	-

7.7 CN1 camera module connector

The 32L496GDISCOVERY offers the possibility to connect a camera module to the CN1 connector as detailed in [Figure 10](#) and [Table 21](#).

Note: The camera only works when the STM32L496AGI6 is supplied with 3.3 V.

Figure 10. CN1 camera module connector (Front view)

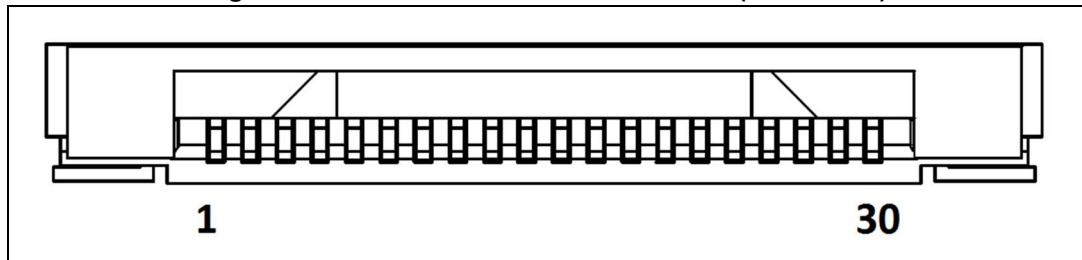

Table 21. CN1 camera module connector

Pin number	Description	Pin number	Description
1	GND	16	GND
2	NC	17	DCMI_HSYNC (PH8)
3	NC	18	NC
4	DCMI_D0 (PH9)	19	DCMI_VSYNC (PI5)
5	DCMI_D1 (PH10)	20	VDD
6	DCMI_D2 (PH11)	21	Camera_CLK (MCU PA8)
7	DCMI_D3 (PH12)	22	NC
8	DCMI_D4 (PH14)	23	GND
9	DCMI_D5 (PI4)	24	NC
10	DCMI_D6 (PE5)	25	DCMI_PWR_EN (MFX_GP6)
11	DCMI_D7 (PI7)	26	RESET#
12	NC	27	DCMI_SDA (PB14)
13	NC	28	DCMI_SCL (PH4)
14	GND	29	GND
15	DCMI_PIXCK (PH5)	30	VDD

7.8 microSD™ card

microSD™ cards with 4 Gbytes or more capacity can be inserted in the receptacle CN17. 4 bits of the SDIO interface including CLK and CMD signals of the STM32L496AG are used to communicate with the microSD™ card. MFX_GPIO8 reads the card detection: when a microSD™ card is inserted, the logic level is 0, otherwise, it is 1. The CN17 connector is detailed in [Figure 11](#) and [Table 22](#).

Note: The microSD™ card only works when the STM32L496AGI6 is supplied with 3.3 V.

Figure 11. CN17 microSD™ card connector (Top view)

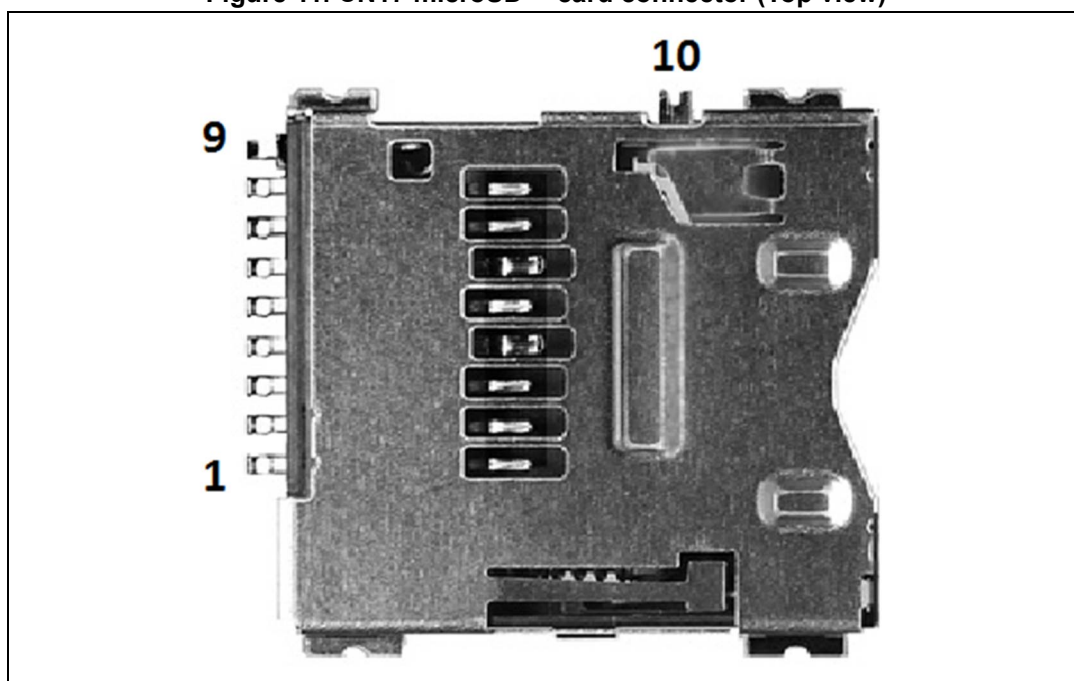

Table 22. CN17 microSD™ card connector

Pin number	Description	Pin number	Description
1	SDIO_D2 (PC10)	6	GND
2	SDIO_D3 (PC11)	7	SDIO_D0 (PC8)
3	SDIO_CMD (PD2)	8	SDIO_D1 (PC9)
4	3V3	9	GND
5	SDIO_CLK (PC12)	10	MicroSD card_detect (MFX_GPIO8)

7.9 LCD

The display is a 1.54-inch 240 x 240 pixels TFT color LCD with a capacitive touch panel. It can display up to 262 K colors. The LCD parallel interface is connected to the FMC of the STM32L496AGI6 by the CN6 connector. By default, the solder bridge SB15 is OFF and the solder bridge SB14 is ON. It sets the IM of the LCD to high, enabling the LCD data bus in 16-bit mode. To use the LCD in 8-bit mode, SB15 must be ON and SB14 OFF.

The FMC_NE1 (PD7) signal performs the selection of the LCD. The write-enable signal is FMC_NWE (PD5) and the read-enable signal is FMC_NOE (PD4). The FMC address A18 signal selects data/command access to the LCD.

The PH7 port must be used as an input of the microcontroller connected to the LCD signal TE (tearing effect). The TE signal is used to synchronize the refresh of the LCD memory by the microcontroller with the LCD scan. Such a synchronization avoids visible artifacts on the display.

The LCD_RESET (MFX_GPIO2) signal gives the possibility to reset the LCD by the microcontroller. [Table 23](#) details the signals of the CN6 LCD connector.

Table 23. CN6 LCD connector

CN6 pin	Signal name	Description	MCU pin involved
1	GND	Ground	GND
2	LCD_TE	Tearing effect output pin to interrupt MCU	PH7
3	D15	Data connected to FMC	PD10
4	D14	Data connected to FMC	PD9
5	D13	Data connected to FMC	PD8
6	D12	Data connected to FMC	PE15
7	D11	Data connected to FMC	PE14
8	D10	Data connected to FMC	PE13
9	D9	Data connected to FMC	PE12
10	D8	Data connected to FMC	PE11
11	D7	Data connected to FMC	PE10
12	D6	Data connected to FMC	PE9
13	D5	Data connected to FMC	PE8
14	D4	Data connected to FMC	PE7
15	D3	Data connected to FMC	PD1
16	D2	Data connected to FMC	PD0
17	D1	Data connected to FMC	PD15
18	D0	Data connected to FMC	PD14
19	/RD	Read of LCD connected to FMC_NOE	PD4
20	/WR	Write of LCD connected to FMC_NWE	PD5
21	RS	Data/Command select connected to A18	PD13
22	/CS	Chip Select of LCD connected to FMC_NE1	PD7
23	RESET	LCD RESET	MFx_GP2
24	IM	8 bits (low)/16bits (high) mode selection pin	n/a
25	IOVCC	LCD I/Os power supply connected to VDD	n/a
26	VCI	Power supply connected to +3V3	n/a
27	GND	Ground	GND
28	LEDA	Anode of backlight LED	n/a
29	LEDK	Cathode of backlight LED	n/a

7.10 Backlight

The LEDK and LEDA signals of the LCD module are the cathode and anode of the backlight LEDs.

Typically, the backlight LEDs require a current source supply of 15 mA capable of delivering a voltage of up to 10 V. The backlight driver circuit, which is a switching mode boost converter powered by the 5 V rail of the board, handles this function.

A high level of the LCD_BLCTRL (PI0) signal switches the backlight on. It is possible to lower backlight intensity by applying a low-frequency PWM signal to LCD_BLCTR, typically from 1 kHz to 10 kHz.

7.11 Touch panel

The touch panel is a capacitive touch panel using an I²C interface. The CN13 10-pin connector of the touch panel is located on the bottom side of the 32L496GDISCOVERY board. The I²C SDA line is connected to PB14 and the I²C SCL line is connected to PH4. The CTP_INT interrupt output is connected to port PG14 as an interruption input of the microcontroller. Port MFX_GPIO1 is the reset of the capacitive touch panel.

Table 24. CN13 touch panel connector

Pin number	Description	Pin number	Description
1	GND	6	GND
2	INT (PG14)	7	RESET (MFX_GPIO1)
3	GND	8	VDD
4	SDA (PB14)	9	VDD
5	SCL (PH4)	10	GND

7.12 CN5 ST-LINK/V2-1 USB Micro-B connector

The CN5 USB connector is used to connect embedded ST-LINK/V2-1 to the PC for the programming and debugging of the STM32L496AGI6 microcontroller.

Figure 12. CN5 USB Micro-B connector (Front view)

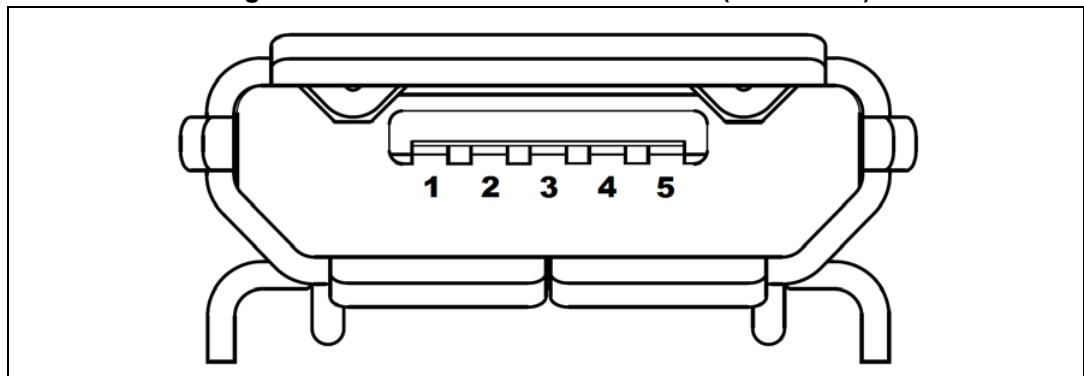

Table 25. CN5 USB Micro-B connector

Pin number	Description	Pin number	Description
1	V _{BUS} (power)	4	GND
2	DM	5, 6	Shield
3	DP	-	-

8 32L496GDISCOVERY board I/O assignment

Table 26. 32L496GDISCOVERY Discovery board I/O assignment

Pin name	Pin number	Signal or label	Note
PA0	K3	TIM2_CH1	-
PA1	N2	ARD_A4	-
PA2	N1	UART2_TX	-
PA3	M2	QSPI_CLK	-
PA4	L3	ADC12_IN9	-
PA5	K4	ARD_D13	ARD_SPI1_CLK, LD3
PA6	M4	QSPI_BK1_IO3	-
PA7	L4	QSPI_BK1_IO2	-
PA8	G8	DCMI_CLK	-
PA9	F10	USB_VBUS	-
PA10	F9	USB_ID	-
PA11	E13	USB_DM	-
PA12	D13	USB_DP	-
PA13	A11	STLK_JTMS	SWDIO
PA14	A10	STLK_JTLK	SWCLK
PA15	A9	ARD_D10	SPI1_NSS/TIM2_CH1
PB0	K5	QSPI_BK1_IO1	-
PB1	L5	QSPI_BK1_IO0	-
PB2	N5	PMOD+ RESET	-
PB3	A6	STLK_JTDO	TRACESWO
PB4	A5	ARD_D12	ARD_SPI1_MISO
PB5	B5	ARD_D11	ARD_SPI1_MOSI
PB6	C5	UART1_TX	-
PB7	D5	ARD_D14	I2C1_SDA
PB8	C4	ARD_D15	I2C1_SCL
PB9	D4	ARD_D5	TIM4_CH4
PB10	N9	SAI1_SCK_A	-
PB11	H8	QSPI_BK1_NCS	-
PB12	N12	DFSDM_DATA1	-
PB13	N13	LED1	-
PB14	M13	I2C2_SDA	-
PB15	M12	SPI2_MOSI	-

Table 26. 32L496GDISCOVERY Discovery board I/O assignment (continued)

Pin name	Pin number	Signal or label	Note
PC0	J2	ARD_A5	-
PC1	J3	ARD_A1	-
PC2	J4	DFSDM_CKOUT	-
PC3	K1	ARD_A2	-
PC4	H5	ARD_A0	-
PC5	J5	MFx_WAKEUP	-
PC6	F11	AUDIO_RST	-
PC7	G12	DFSDM_DATA3	-
PC8	G10	SD_D0	-
PC9	G9	SD_D1	-
PC10	D9	SD_D2	-
PC11	E9	SD_D3	-
PC12	F8	SD_CLK	-
PC13	E1	JOY_SEL	WAKEUP
PC14 OSC32_IN	F1	OSC32_IN	-
PC15 OSC32_OUT	G1	OSC32_OUT	-
PD0	B8	PSRAM_D2	LCD_D2
PD1	C8	PSRAM_D3	LCD_D3
PD2	D8	SD_CMD	-
PD3	E8	SPI2_MISO	-
PD4	C7	PSRAM_NOE	LCD_NOE
PD5	D7	PSRAM_NWE	LCD_NWE
PD6	E7	UART2_RX	-
PD7	F7	LCD_NE1	-
PD8	L11	PSRAM_D13	LCD_D13
PD9	L10	PSRAM_D14	LCD_D14
PD10	J13	PSRAM_D15	LCD_D15
PD11	K12	PSRAM_A16	-
PD12	K11	PSRAM_A17	-
PD13	K13	PSRAM_A18	LCD_RS
PD14	K10	PSRAM_D0	LCD_D0
PD15	H11	PSRAM_D1	LCD_D1
PE0	A4	PSRAM_NBL0	-
PE1	B4	PSRAM_NBL1	-
PE2	D3	SAI1_MCLK_A	-

Table 26. 32L496GDISCOVERY Discovery board I/O assignment (continued)

Pin name	Pin number	Signal or label	Note
PE3	D2	SAI1_SD_B	-
PE4	D1	SAI1_FS_A	-
PE5	E4	DCMI_D6	-
PE6	E3	SAI1_SD_A	-
PE7	L7	PSRAM_D4	LCD_D4
PE8	K7	PSRAM_D5	LCD_D5
PE9	J7	PSRAM_D6	LCD_D6
PE10	H7	PSRAM_D7	LCD_D7
PE11	N8	PSRAM_D8	LCD_D8
PE12	M8	PSRAM_D9	LCD_D9
PE13	L8	PSRAM_D10	LCD_D10
PE14	K8	PSRAM_D11	LCD_D11
PE15	J8	PSRAM_D12	LCD_D12
PF0	F5	PSRAM_A0	LCD_RS
PF1	F4	PSRAM_A1	-
PF2	F3	PSRAM_A2	-
PF3	G3	PSRAM_A3	-
PF4	G4	PSRAM_A4	-
PF5	G5	PSRAM_A5	-
PF10	H4	ARD_A3	-
PF11	M5	JOY_RIGHT	-
PF12	N6	PSRAM_A6	-
PF13	M6	PSRAM_A7	-
PF14	L6	PSRAM_A8	-
PF15	K6	PSRAM_A9	-
PG0	J6	PSRAM_A10	-
PG1	H6	PSRAM_A11	-
PG2	J12	PSRAM_A12	-
PG3	J11	PSRAM_A13	-
PG4	J10	PSRAM_A14	-
PG5	J9	PSRAM_A15	-
PG6	G11	ARD_D7	-
PG7	H10	ARD_D1	LPUART1_TX
PG8	H9	ARD_D0	LPUART1_RX
PG9	B7	PSRAM_NE2	-

Table 26. 32L496GDISCOVERY Discovery board I/O assignment (continued)

Pin name	Pin number	Signal or label	Note
PG10	D6	UART1_RX	-
PG11	E6	UART1_CTS	SPI2_NSS
PG12	F6	UART1_RTS	-
PG13	G7	ARD_D2	-
PG14	G6	CTP_INT	-
PG15	C6	ARD_D8	-
PH0	H1	LCD_PWR_ON	-
PH1	G1	MIC_VDD	-
PH2	A2	PMOD_INT	-
PH3	E5	BOOT0	-
PH4	K9	I2C2_SCL	-
PH5	L9	DCMI_PIXCLK	-
PH6	E11	MFX_INT	-
PH7	D12	LCD_TE	-
PH8	N10	DCMI_HSYNC	-
PH9	D11	DCMI_D0	-
PH10	M9	DCMI_D1	-
PH11	M10	DCMI_D2	-
PH12	B13	DCMI_D3	-
PH13	C9	ARD_D9	TIM8_CH1N
PH14	A13	DCMI_D4	-
PH15	B12	ARD_D3	TIM8_CH3N
PI0	A12	LCD_BL	TIM5_CH4
PI1	B11	SPI2_CLK	-
PI2	B10	SPI2_MISO	-
PI3	C10	SPI2_MOSI	-
PI4	D10	DCMI_D5	-
PI5	E10	DCMI_VSYNC	-
PI6	B9	ARD_D6	TIM8_CH2
PI7	B2	DCMI_D7	-
PI8	C11	JOY_UP	-
PI9	B1	JOY_LEFT	-
PI10	A1	JOY_DOWN	-
PI11	C3	ARD_D4	-

9 Pmod™ and STMod+ schematic table

[Table 27](#) describes the signals available on the STMod+ connector. It also shows which signal is shared with other board connectors (such as Pmod™ or ARDUINO® Uno V3 as listed in columns Pmod™ and ARD respectively). When the I²C bus (pins 7 and 10) is shared with built-in discovery target devices, it is recommended to check the device target address when adding it to the bus. Refer to the following list of acronyms before reading [Table 27](#):

- NSS2 stands for SPI2_NSS
- LT2.O stands for LPTIM2_OUT
- LT1.2 stands for LPTIM1_IN2
- LT1.E stands for LPTIM1_ETR
- T15.2 stands for TIM15 CH2
- SCL4 stands for I2C4_SCL
- SDA1 stands for I2C1_SDA
- DFS1.D5 stands for DFSDM1_DATIN5
- DFS1.CI2 stands for DFSDM1_CKIN2
- DFS1.CO stands for DFSDM1_CKOUT
- RX1 stands for USART1_RX
- UCK3 stands for USART3_CK
- CTS2 stands for USART2_CTS
- LRTS1 stands for LPUART_RTS1
- CRX1 stands for CAN1_RX



Table 27. STMod+ connector signals

-	-	-	STMod+								-	-	-
ARD	Pmod™	Some other alternate functions	Basic	SB	Port	Pin	Port	SB	Basic	Some other alternate functions	Pmod™	ARD	
-	CTS/NSS	LT1.2/T15.2	CTS1/NSS2	-	PG11	1	11	PH2	-	INT	-	INT	-
-	TX	LT1.E/T4.1/SCL1 /SCL4/DFS1.D5	TX1	7	PB6	2	12	PB2	-	RST	RTC_OUT/LT1.O/DFS1.CI0	RST	-
-	MOSI	DFS1.C2/T15.2/RTC_REFIN	MOSI2p	4	PB15		13	PA4	-	ADC	CK2/LT2.O	-	-
-	RX	LT1.1/T15.1	RX1	8	PG10	3	14	PA0	-	PWM	T2.1/T5.1/T8.E/CTS2/TX4/T2.E/RTC_TAMP2/WKUP1	-	-
-	MISO	T8.4	MISO2p	5	PI2		15	+5V	-	+5V	-	-	-
-	RTS	LT1.E	RTS1	6	PG12	4	16	GND	-	GND	-	-	-
-	SCK	-	SCK2	9	PI1		17	PC7	-	GPIO	T3.2/T8.2/ DFS1.D3	-	-
-	-	-	GND	-	GND	5	18	PC2	-	GPIO	LT1.2/MISO2/DFS1.CO	-	-
-	-	-	+5V	-	+5V	6	19	PBI2	-	GPIO	NSS2/DFS1.D1/UCK3/LRTS1	-	-
SCL1	-	T4.3/SCL1/DFS1.D6/T16.1/CRX1	SCL1	-	PB8	7	20	PC2	-	GPIO	Same as pin 18	-	-
-	-	T8.E	MOSI2s	-	PI3	8							
-	-	SCK2/DFS1.D0	MISO2s	-	PD3	9							
SDA1	-	LT1.2/T4.2/SDA1/DFS1.CI5/RX1	SDA1	-	PB7	10							

Note: SB stands for solder bridge. The text in bold refers to default (USART).

10 Fanout board

The fanout board comes with the 32L496GDISCOVERY Discovery board.

It is connected to the STMod+ connector (CN2) and provides access to:

- MikroElektronika mikroBUS™ Click-board compatible connectors (CN10 and CN11: two 1x8-pin male connectors)
- ESP-01 compatible connector (CN4: 2x4-pin male connector)
- Seeed Studio™ Grove compatible connectors (CN3 and CN2: two 1x4-pin male connectors)
- Reserved standard 2.54 mm pitch of STMod+ pin header for breadboard.

Figure 13. STMod+ Fanout module plugged into CN2 connector

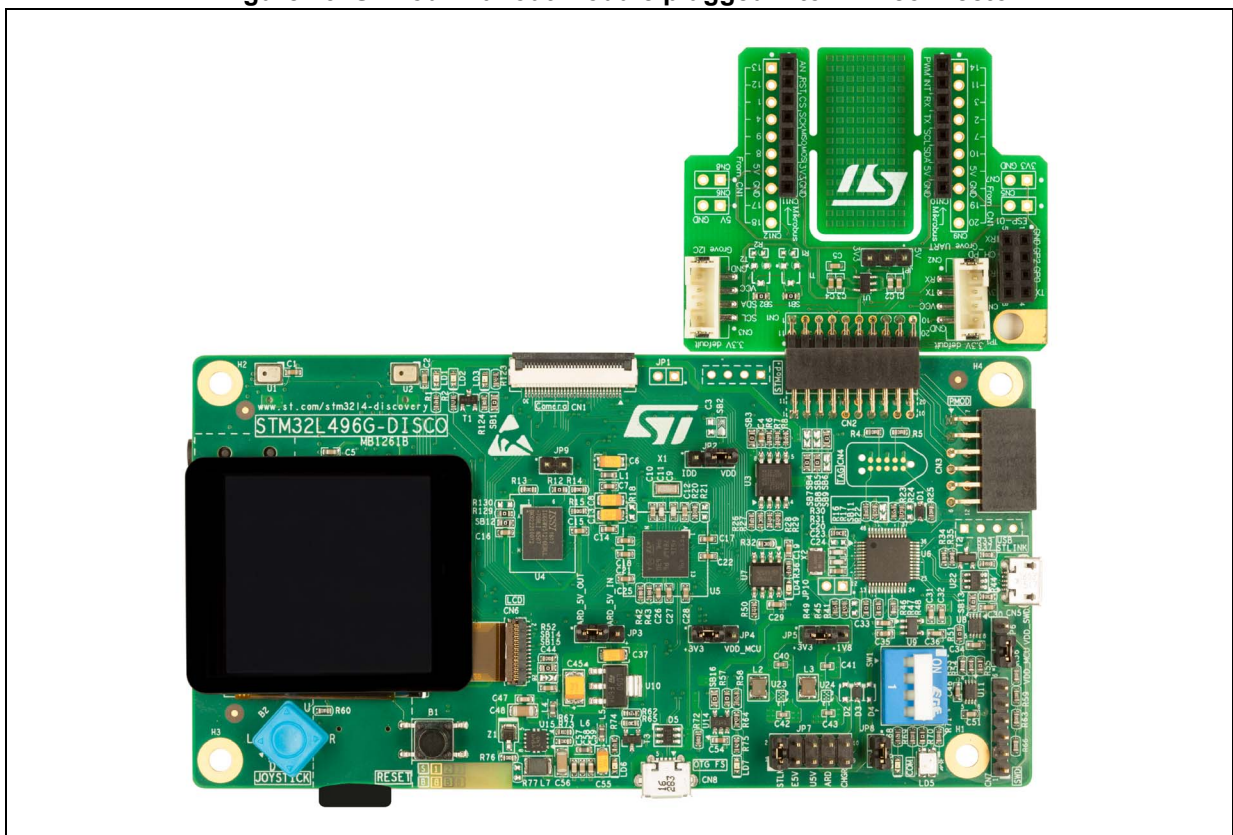

10.1 MikroElektronika mikroBUS™ compatible connector (Fanout CN10 and CN11)

The mikroBUS™ compatible connector is 2.54" pitch with a pair of 1x8-pin female connectors. [Table 28](#) below shows the definition of the pins.

Table 28. Description of the mikroBUS™ connector pins

STMod+ connector CN11 number	Function of mikroBUS	Pin number	Pin number	Function of mikroBUS	STMod+ connector CN10 number
STMod+#13-ADC ⁽¹⁾	AN	1	1	PWM	STMod+#14-PWM ⁽¹⁾
STMod+#12-RST	RST	2	2	INT	STMod+#11-INT
STMod+#1-NSS	CS	3	3	RX	STMod+#3-RX
STMod+#4-SCK	SCK	4	4	TX	STMod+#2-TX
STMod+#9-MISOs	MISO	5	5	SCL	STMod+#7-SCL ⁽²⁾
STMod+#8-MOSIs	MOSI	6	6	SDA	STMod+#10-SDA ⁽²⁾
-	+3.3 V	7	7	+5 V	-
-	GND	8	8	GND	-

1. Exclusive use: ARDUINO® or STMod+.

2. Shared with ARDUINO®.

The mikroBUS™ pinout assignment is available at the: <http://mikroe.com> website.

11 32L496GDISCOVERY board information

11.1 Product marking

The product and each board composing the product are identified with one or several stickers. The stickers, located on the top or bottom side of each PCB, provide product information:

- Main board featuring the target device: product order code, product identification, serial number, and board reference with revision.

Single-sticker example:

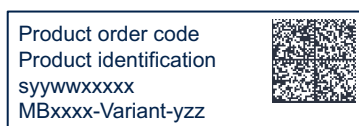

Dual-sticker example:



- Other boards if any: board reference with revision and serial number.

Examples:



On the main board sticker, the first line provides the product order code, and the second line the product identification.

On all board stickers, the line formatted as “*MBxxxx-Variant-yyz*” shows the board reference “*MBxxxx*”, the mounting variant “*Variant*” when several exist (optional), the PCB revision “*y*”, and the assembly revision “*zz*”, for example B01. The other line shows the board serial number used for traceability.

Products and parts labeled as “*ES*” or “*E*” are not yet qualified or feature devices that are not yet qualified. STMicroelectronics disclaims any responsibility for consequences arising from their use. Under no circumstances will STMicroelectronics be liable for the customer’s use of these engineering samples. Before deciding to use these engineering samples for qualification activities, contact STMicroelectronics’ quality department.

“*ES*” or “*E*” marking examples of location:

- On the targeted STM32 that is soldered on the board (for an illustration of STM32 marking, refer to the STM32 datasheet *Package information* paragraph at the www.st.com website).
- Next to the evaluation tool ordering part number that is stuck or silk-screen printed on the board.

Some boards feature a specific STM32 device version, which allows the operation of any bundled commercial stack/library available. This STM32 device shows a “*U*” marking option at the end of the standard part number and is not available for sales.

To use the same commercial stack in their applications, the developers might need to purchase a part number specific to this stack/library. The price of those part numbers includes the stack/library royalties.

11.2 32L496GDISCOVERY product history

Table 29. Product history

Order code	Product identification	Product details	Product change description	Product limitations
STM32L496G-DISCO	32L496GDISCO/	MCU: – STM32L496AGI6 silicon revision 'B'	Initial revision	No limitation
		MCU errata sheet: – <i>STM32L496xx/4A6xx</i> <i>device errata</i> (ES0335)		
		Boards: – MB1261-L496G-B01 (main board) – MB1280-DEFAULT-A03 (fanout board)		
	DK32L496G\$AU1	MCU: – STM32L496AGI6 silicon revision 'B'	– Main board revision changed – Fanout board revision changed – Packaging: plastic blister replaced by a carton box	No demonstration software preloaded in this product identification
		MCU errata sheet: – <i>STM32L496xx/4A6xx</i> <i>device errata</i> (ES0335)		
		Boards: – MB1261-L496G-B06 (main board) – MB1280-3V3-C01 (fanout board)		
DK32L496G\$AU2	MCU: – STM32L496AGI6 silicon revision 'B'	– Main board revision changed – Board stickers format changed	No limitation	
	MCU errata sheet: – <i>STM32L496xx/4A6xx</i> <i>device errata</i> (ES0335)			
	Boards: – MB1261-L496G-B07 (main board) – MB1280-3V3-C01 (fanout board)			

11.3 Board revision history

Table 30. Board revision history

Board reference	Board variant and revision	Board change description	Board limitations
MB1261 (main board)	L496G-B01	Initial revision	No limitation
	L496G-B06	EOL parts replacement, such as LCD FRIDA FRD154BP2901 replaced by FRIDA FRD154B2902-D-CTQ, with impact on firmware. Refer to the bill of materials for details.	No limitation
	L496G-B07	EOL parts replacement, such as LCD FRIDA FRD154B2902-D-CTQ replaced by FRIDA FRD154H29003-A-CTQ, with impact on firmware. Refer to the bill of materials for details.	No limitation
MB1280 (fanout board)	DEFAULT-A03	Initial revision	No limitation
	3V3-C01	Updated <ul style="list-style-type: none"> – Several part references due to obsolescence, such as transistors. Refer to the bill of materials for details. – T1 and T2 wiring – Silkscreens, logos, and PCB mechanical size 	No limitation

12 Federal Communications Commission (FCC) and ISED Canada Compliance Statements

12.1 FCC Compliance Statement

Part 15.19

This device complies with Part 15 of the FCC Rules. Operation is subject to the following two conditions: (1) this device may not cause harmful interference, and (2) this device must accept any interference received, including interference that may cause undesired operation.

Part 15.21

Any changes or modifications to this equipment not expressly approved by STMicroelectronics may cause harmful interference and void the user's authority to operate this equipment.

Part 15.105

This equipment has been tested and found to comply with the limits for a Class A digital device, pursuant to part 15 of the FCC Rules. These limits are designed to provide reasonable protection against harmful interference when the equipment is operated in a commercial environment. This equipment generates, uses, and can radiate radio frequency energy and, if not installed and used in accordance with the instruction manual, may cause harmful interference to radio communications. Operation of this equipment in a residential area is likely to cause harmful interference in which case the user will be required to correct the interference at his own expense.

Responsible party (in the USA)

Francesco Doddo
STMicroelectronics, Inc.
200 Summit Drive | Suite 405 | Burlington, MA 01803
USA
Telephone: +1 781-472-9634

12.2 ISED Compliance Statement

This device complies with the ISED Canada RF radiation exposure limits set forth for general population for mobile application (uncontrolled exposure). This device must not be collocated or operating in conjunction with any other antenna or transmitter.

Compliance Statement

Notice: This device complies with Industry Canada license-exempt RSS standard(s). Operation is subject to the following two conditions: (1) this device may not cause interference, and (2) this device must accept any interference, including interference that may cause undesired operation of the device.

ISED Canada ICES-003 Compliance Label: CAN ICES-3 (A) / NMB-3 (A).

Déclaration de conformité

Avis: Le présent appareil est conforme aux CNR d'ISDE Canada applicables aux appareils radio exempts de licence. L'exploitation est autorisée aux deux conditions suivantes: (1) l'appareil ne doit pas produire de brouillage, et (2) l'utilisateur de l'appareil doit accepter tout brouillage radioélectrique subi, même si le brouillage est susceptible d'en compromettre le fonctionnement

Étiquette de conformité à la NMB-003 d'ISDE Canada: CAN ICES-3 (A) / NMB-3 (A).

13 CE conformity

13.1 Warning

EN 55032 / CISPR32 (2012) Class A product

Warning: this device is compliant with Class A of EN55032 / CISPR32. In a residential environment, this equipment may cause radio interference.

14 Product disposal

Disposal of this product: WEEE (Waste Electrical and Electronic Equipment)

(Applicable in Europe)

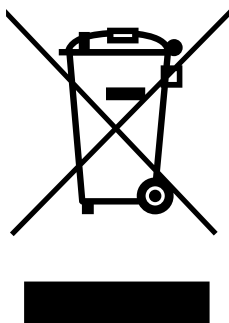

This symbol on the product, accessories, or accompanying documents indicates that the product and its electronic accessories should not be disposed of with household waste at the end of their working life.

To prevent possible harm to the environment and human health from uncontrolled waste disposal, please separate these items from other type of waste and recycle them responsibly to the designated collection point to promote the sustainable reuse of material resources.

Household users:

You should contact either the retailer where you buy the product or your local authority for further details of your nearest designated collection point.

Business users:

You should contact your dealer or supplier for further information.

Revision history

Table 31. Document revision history

Date	Revision	Changes
2-Mar-2017	1	Initial release.
8-Nov-2018	2	Added: – Table 13: 32L496GDISCOVERY non-user LEDs Updated: – Figure 3 , Figure 4 , Table 12 , Table 15 , and Table 26 with LD3.
14-Apr-2022	3	Reshuffled document from Introduction to Conventions to the latest standards Added: – 32L496GDISCOVERY board information Updated: – Figure 3 to Figure 5 – Federal Communications Commission (FCC) and Innovation, Science and Economic Development Canada (ISED) Compliance Statements Removed: – Electrical schematics .
24-Mar-2025	4	Updated: – Features aligned with the associated data brief – Ordering Information table with fanout board information – 32L496GDISCOVERY board information Added: – Safety recommendations – CE conformity – Product disposal

IMPORTANT NOTICE – READ CAREFULLY

STMicroelectronics NV and its subsidiaries ("ST") reserve the right to make changes, corrections, enhancements, modifications, and improvements to ST products and/or to this document at any time without notice. Purchasers should obtain the latest relevant information on ST products before placing orders. ST products are sold pursuant to ST's terms and conditions of sale in place at the time of order acknowledgment.

Purchasers are solely responsible for the choice, selection, and use of ST products and ST assumes no liability for application assistance or the design of purchasers' products.

No license, express or implied, to any intellectual property right is granted by ST herein.

Resale of ST products with provisions different from the information set forth herein shall void any warranty granted by ST for such product.

ST and the ST logo are trademarks of ST. For additional information about ST trademarks, refer to www.st.com/trademarks. All other product or service names are the property of their respective owners.

Information in this document supersedes and replaces information previously supplied in any prior versions of this document.

© 2025 STMicroelectronics – All rights reserved