

450 W motor control power board based on STIPQ5M60T-H SLLIMM™-nano 2nd series MOSFET IPM

Introduction

The STEVAL-IPMN5Q is a compact motor drive power board equipped with SLLIMM-nano (small low-loss intelligent molded module) 2nd series based on N-channel Power MOSFET MDmesh™ DM2 fast-recovery diode (STIPQ5M60T-HL). It provides an affordable and easy-to-use solution for driving high power motors in a wide range of applications such as power white goods, air conditioning, compressors, power fans and 3-phase inverters for motor drives in general.

The IPM itself consists of six MOSFETs, three high voltage half-bridge gate driver ICs and a wide range of features like undervoltage lockout, smart shutdown, internal temperature sensor and NTC, overcurrent protection and internal op-amp. The main characteristics of this evaluation board are small size, minimal BOM and high efficiency. It features an interface circuit (BUS and VCC connectors), bootstrap capacitors, snubber capacitor, hardware short-circuit protection, fault event signal and temperature monitoring. It is designed to work in single- or three-shunt configuration and with triple current sensing options: three dedicated on-board op-amps, op-amps embedded on MCU or single internal IPM op-amp. The Hall/Encoder part completes the circuit.

The system is designed to achieve accurate and fast conditioning of current feedback to satisfy the typical requirements for field oriented control (FOC).

The STEVAL-IPMN5Q is compatible with ST's control board based on STM32, providing a complete platform for motor control.

Figure 1. Motor control board based on SLIMM-nano 2nd series - top view

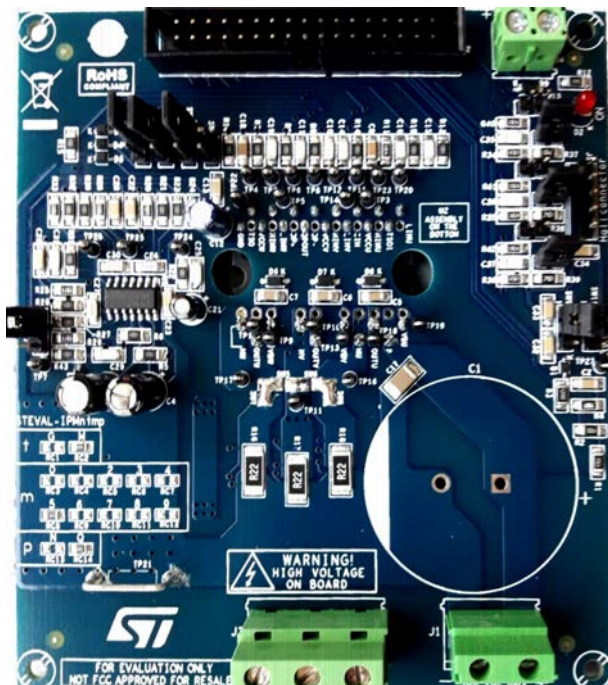
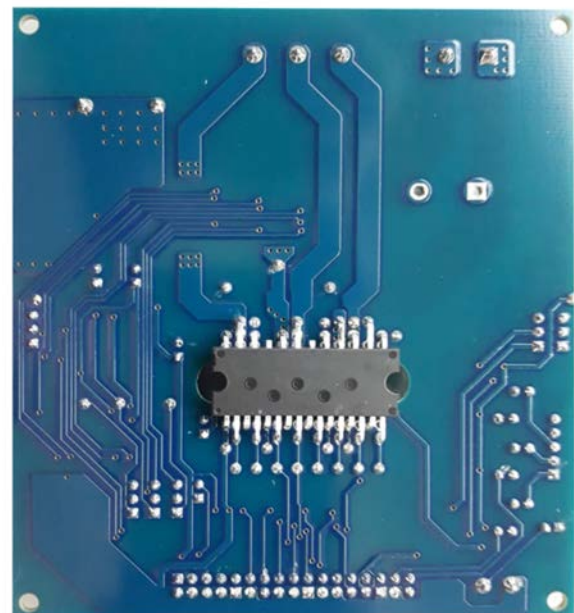

Figure 2. Motor control board based on SLIMM-nano 2nd series - bottom view



1 Key features

- Input voltage: from 125 to 400 V_{DC}
- Nominal power: up to 450 W
 - Allowable maximum power is related to the application conditions and cooling system
- Nominal current: up to 1.8 Arms
- Input auxiliary voltage: up to 20 VDC
- Single- or three-shunt resistors for current sensing (with sensing network)
- Three options for current sensing: dedicated external op-amps, internal SLLIMM-nano op-amp (single) or via MCU
- Overcurrent hardware protection
- IPM temperature monitoring and protection
- Hall sensor or encoder input
- MOSFETs intelligent power module:
 - SLLIMM-nano 2nd series IPM (STIPQ5M60T-H) - Full molded package
- Motor control connector (32 pins) interfacing with ST MCU boards
- Universal design for further evaluation with breadboard and testing pins
- Very compact size
- WEEE compliant
- RoHS compliant

2 Circuit schematics

The full schematics for the SLLIMM-nano card for [STIPQ5M60T-H](#) IPM products is shown below. This card consists of an interface circuit (BUS and VCC connectors), bootstrap capacitors, snubber capacitor, short-circuit protection, fault output circuit, temperature monitoring, single-/three-shunt resistors and filters for input signals. It also includes bypass capacitors for VCC and bootstrap capacitors. The capacitors are located very close to the drive IC to avoid malfunction due to noise.

Three current sensing options are provided: three dedicated onboard op-amps, one internal IPM op-amp and the embedded MCU op-amps; selection is performed through three jumpers.

The Hall/Encoder section (powered at 5 V or 3.3 V) completes the circuit.

2.1 Schematic diagrams

Figure 3. STEVAL-IPMNM5Q board schematic (1 of 5)

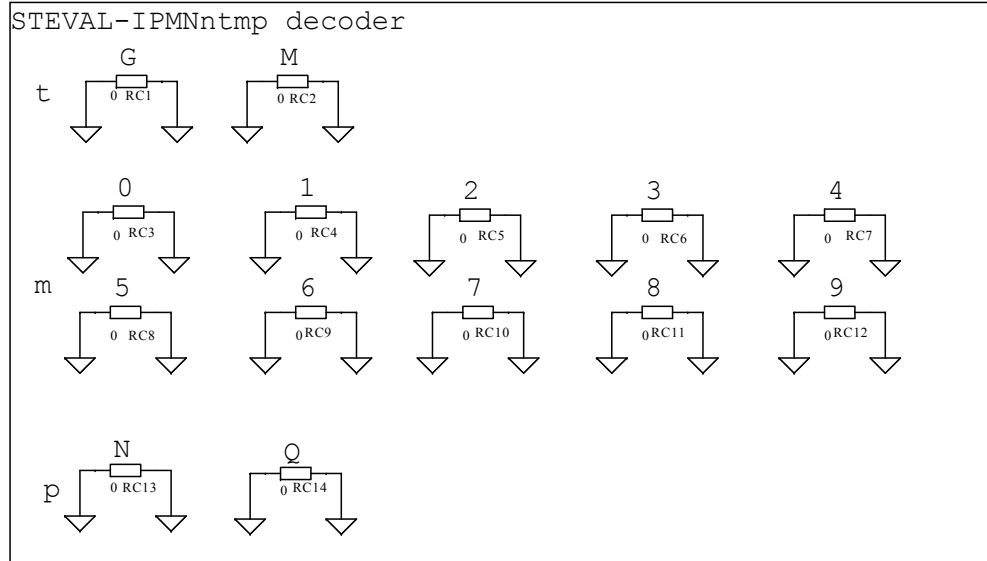
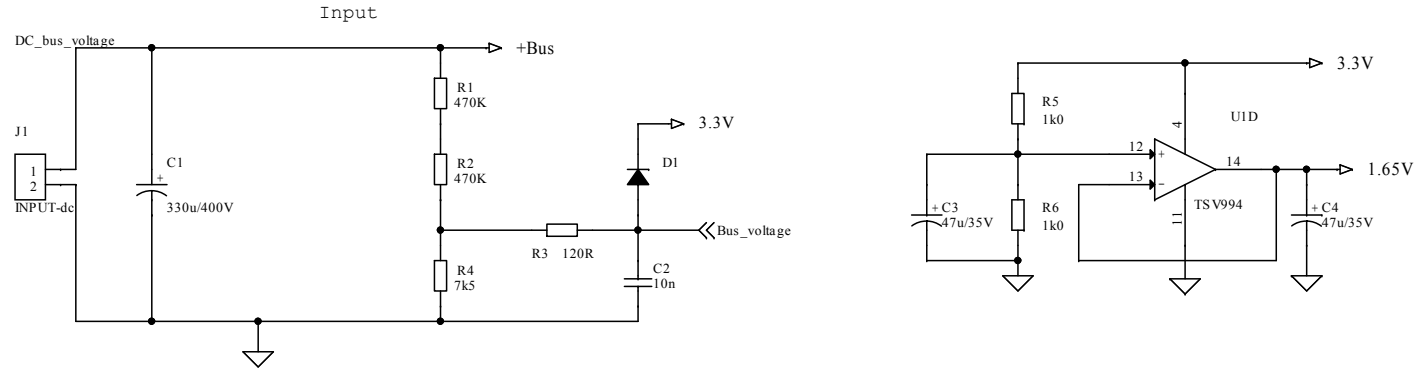

Figure 4. STEVAL-IPMNM5Q board schematic (2 of 5)

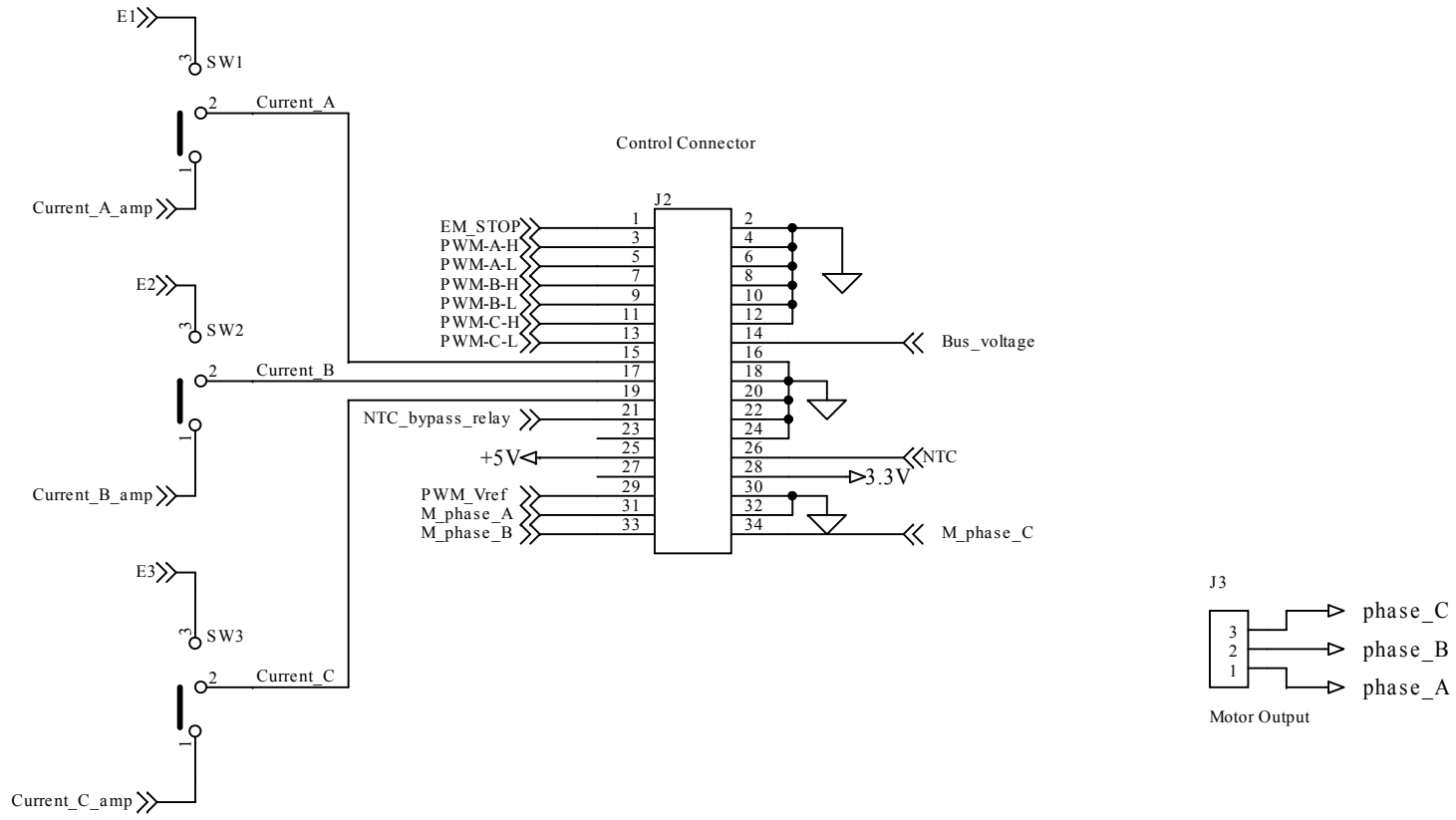

Figure 5. STEVAL-IPMNM5Q board schematic (3 of 5)

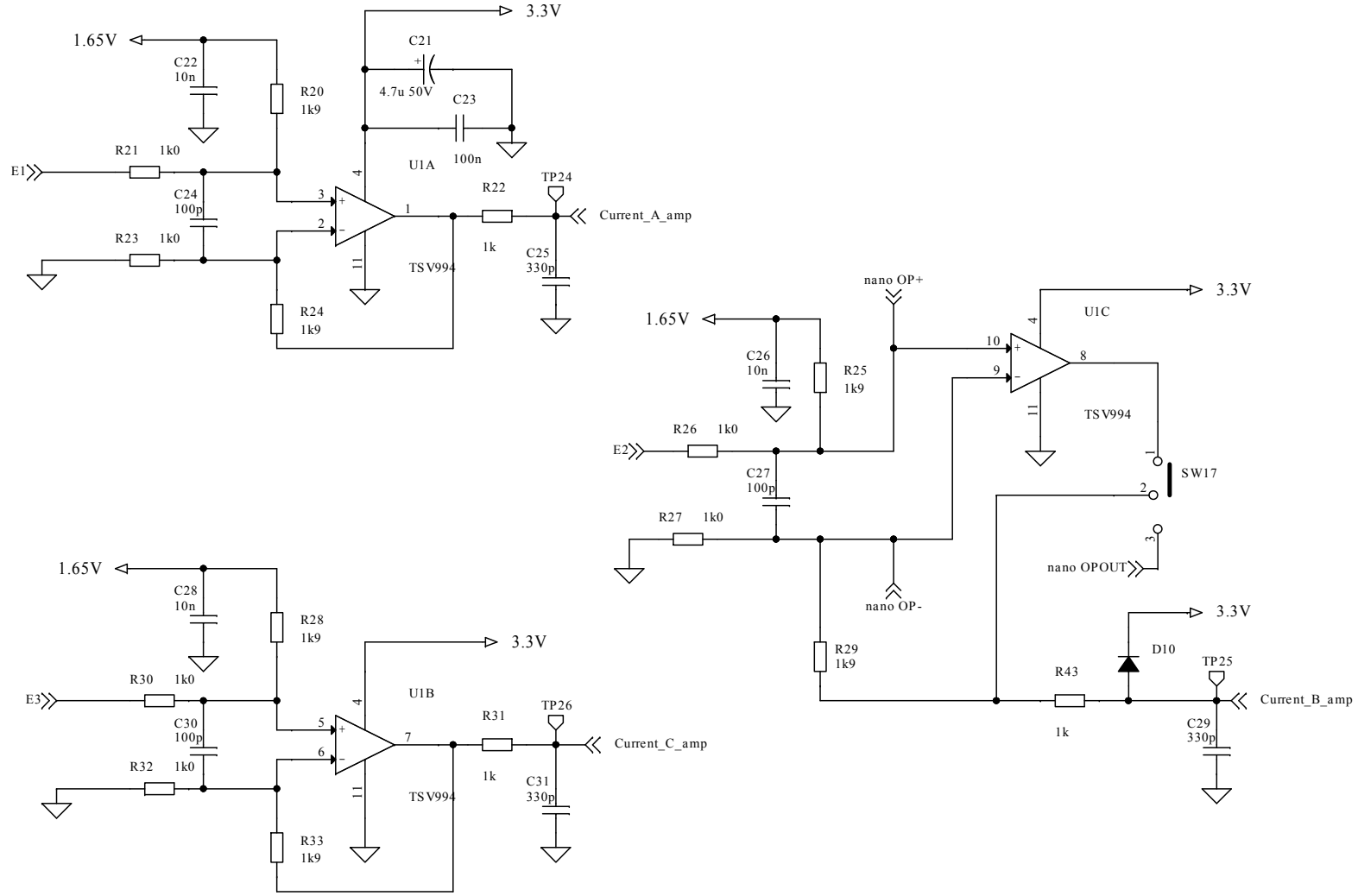

Figure 6. STEVAL-IPMNM5Q board schematic (4 of 5)

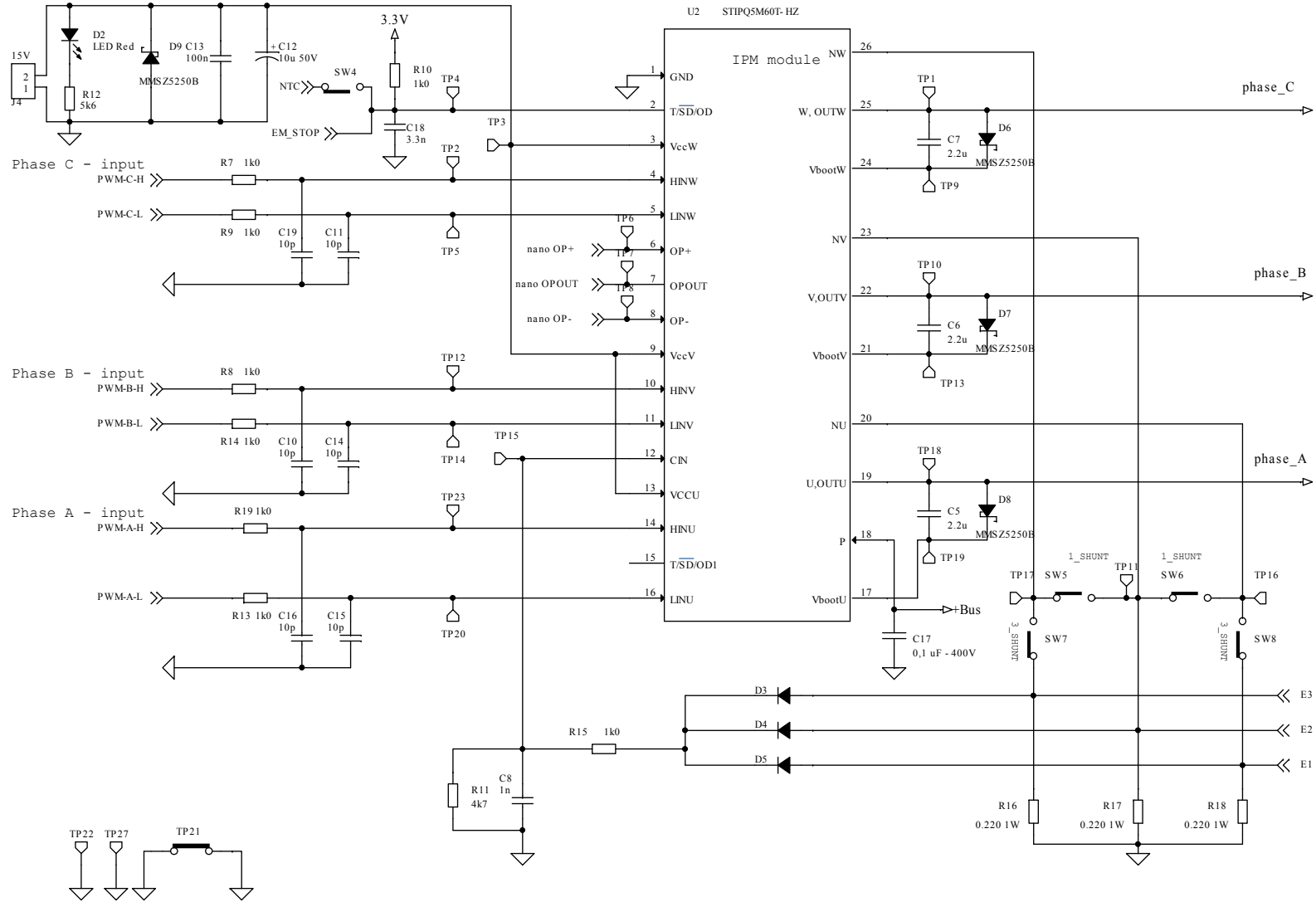
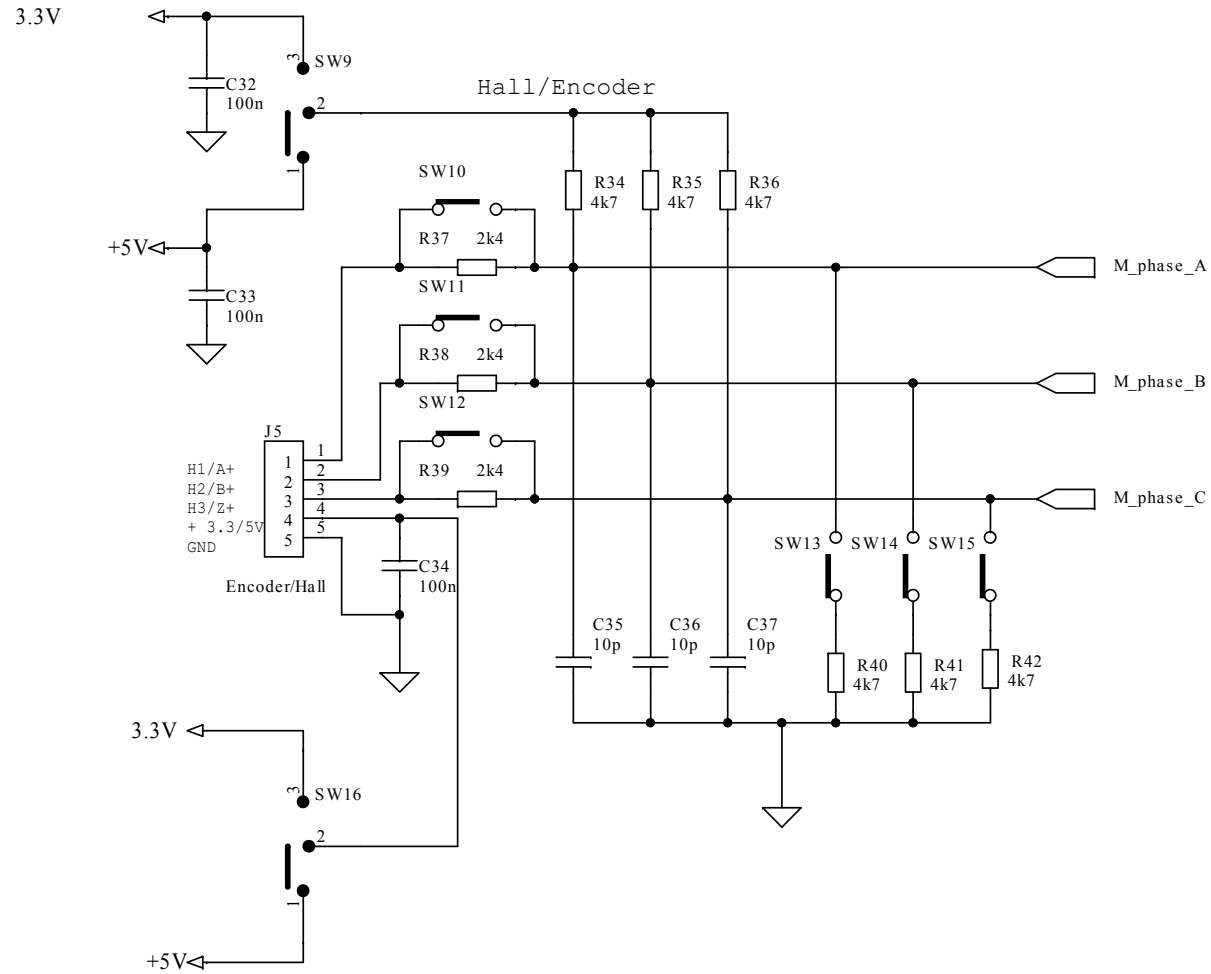

Figure 7. STEVAL-IPMNM5Q board schematic (5 of 5)



3 Main characteristics

The board is designed for a 125 VDC to 400 VDC supply voltage.

An appropriate bulk capacitor for the power level of the application must be mounted at the dedicated position on the board.

The SLLIMM-nano integrates six MOSFET switches and high voltage gate drivers. Thanks to this integrated module, the system offers power inversion in a simple and compact design that requires less PCB area and increases reliability.

The board offers the added flexibility of being able to operate in single- or three-shunt configuration by modifying solder bridge jumper settings (see Section 4.3.4 Single- or three-shunt selection).

Figure 8. STEVAL-IPMNM5Q architecture

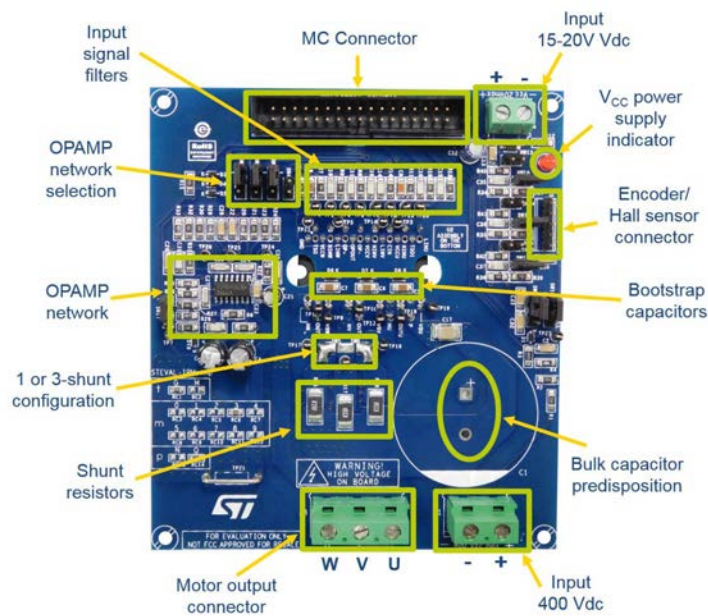

4 Filters and key parameters

4.1 Input signals

The input signals (LINx and HINx) to drive the internal MOSFETs are active high. A 375 k Ω (typ.) pull-down resistor is built-in for each input signal. To prevent input signal oscillation, an RC filter is added on each input as close as possible to the IPM. The filter is designed using a time constant of 10 ns (1 k Ω and 10 pF).

4.2 Bootstrap capacitor

In the 3-phase inverter, the emitters of the low side MOSFETs are connected to the negative DC bus (VDC-) as common reference ground, which allows all low side gate drivers to share the same power supply, while the emitter of the high side MOSFETs is alternatively connected to the positive (VDC+) and negative (VDC-) DC bus during running conditions.

A bootstrap method is a simple and cheap solution to supply the high voltage section. This function is normally accomplished by a high voltage fast recovery diode. The SLLIMM-nano MOSFET-based family includes a patented integrated structure that replaces the external diode with a high voltage DMOS functioning as a diode with series resistor. An internal charge pump provides the DMOS driving voltage.

The value of the CBOOT capacitor should be calculated according to the application requirements.

Figure 9. CBOOT graph selection shows the behavior of CBOOT (calculated) versus switching frequency (f_{sw}), with different values of ΔV_{CBOOT} for a continuous sinusoidal modulation and a duty cycle $\delta = 50\%$.

Note:

This curve is taken from application note AN5244 (available on www.st.com); calculations are based on the STIPN2M50x-Hy device, which represents the worst case scenario for this kind of calculation.

The boot capacitor must be two or three times larger than the C_{BOOT} calculated in the graph.

For this design, a value of 2.2 μF was selected.

Figure 9. CBOOT graph selection

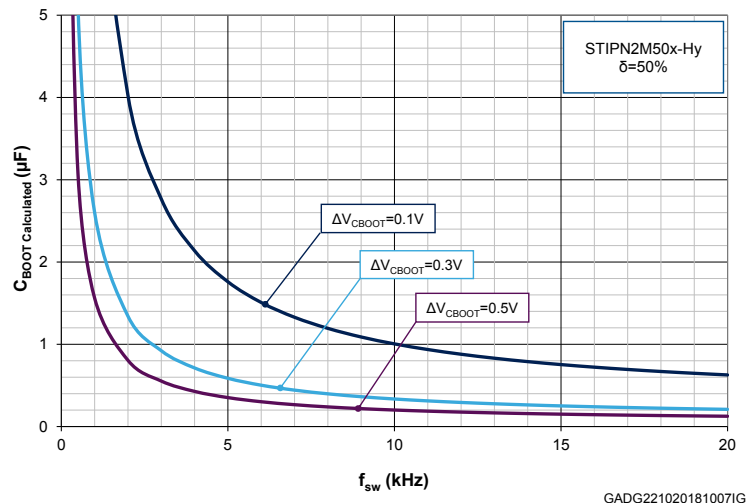

4.3 Overcurrent protection

The SLLIMM-nano MOSFET-based integrates a comparator for fault sensing purposes. The comparator has an internal voltage reference VREF (540 mV typ.) connected to the inverting input, while the non-inverting input on the CIN pin can be connected to an external shunt resistor to implement the overcurrent protection function.

When the comparator triggers, the device enters the shutdown state.

The comparator output is connected to the SD pin in order to send the fault message to the MCU.

4.3.1 SD pin

The \overline{SD} is an input/output pin (open drain type if used as output) used for enable and fault; it is shared with NTC thermistor, internally connected to GND.

The pull-up resistor (R10) causes the voltage V_{SD-GND} to decrease as the temperature increases. To maintain the voltage above the high-level logic threshold, the pull-up resistor is sized at 1 k Ω (3.3 V MCU power supply).

The filter on \overline{SD} (R10 and C18) must be sized to obtain the desired re-starting time after a fault event and placed as close as possible to the pin.

A shutdown event can be managed by the MCU; in which case, the SD functions as the input pin.

Conversely, the SD functions as an output pin when an overcurrent or undervoltage condition is detected.

4.3.2 Shunt resistor selection

The value of the shunt resistor is calculated by the following equation:

$$R_{SH} = \frac{V_{ref}}{I_{OC}} \quad (1)$$

Where is the internal comparator (CIN) (0.54 V typ.) and is the current of overcurrent detection level.

The maximum value of overcurrent protection level should be set less than the pulsed collector current in the datasheet. In this design the over current threshold level is fixed @ = 3.64 A.

$$R_{SH} = \frac{V_{ref} \cdot \left(\frac{R23 + R53}{R53} \right) + V_F}{I_{OC}} = \frac{0.54 \cdot \left(\frac{1000 + 4700}{4700} \right) + 0.18}{3.64} = 0.2294\Omega \quad (2)$$

Where V_F is the voltage drop across diodes D3, D4 and D5.

The commercial value chosen was 0.22 Ω to which corresponds a level of 3.9 A.

The power rating of the shunt resistor is calculated by the following equation:

$$P_{SH} = \frac{1}{2} \cdot \frac{I_{load(max)}^2 \cdot R_{SH} \cdot margin}{Derating\ ratio} \quad (3)$$

where:

- Maximum load current of inverter: $I_{load(max)}$
- Shunt resistor value at $T_C = 25^\circ C$
- Power derating ratio of shunt resistor at $T_{SH} = 100^\circ C$
- Safety margin of 30%

$I_{load(max)}$ is calculated considering the RMS value of the IPM nominal current including a safety margin:

$$I_{load(max)} = \frac{I_{nom(@80^\circ C)}}{\sqrt{2}} \times 0.85 = 1.69 Arms \quad (4)$$

Power shunt value is:

$$P_{SH} = \frac{1}{2} \cdot \frac{1.69^2 \cdot 0.22 \cdot 1.3}{0.8} = 0.509W \quad (5)$$

Considering available commercial values, a 1 W shunt resistor was selected.

Based on the previous equations and conditions, the minimum shunt resistance and power rating is summarized below.

Table 1. Shunt selection

Device	OCP(peak) [A]	$I_{load(max)}$ [Arms]	R_{SHUNT} [Ω]	Shunt power rating P_{SH} [W]
STIPQ3M60T-HL	3.9	1.69	0.22	1

4.3.3 CIN RC filter

An RC filter network on the CIN pin is required to prevent short-circuits due to the noise on the shunt resistor. In this design, the R15-C8 RC filter has a constant time of about 1 μs .

4.3.4 Single- or three-shunt selection

Single- or three-shunt resistor circuits can be adopted by setting the solder bridges SW5, SW6, SW7 and SW8. The figures below illustrate how to set up the two configurations.

Figure 10. One-shunt configuration

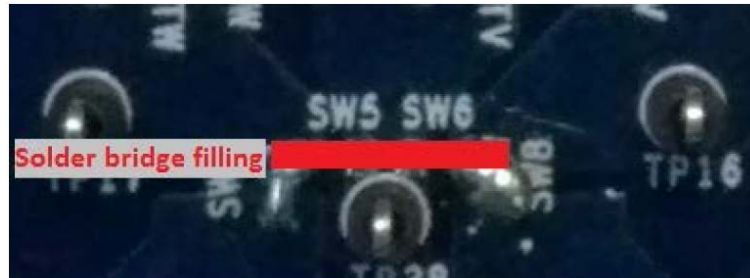

Figure 11. Three-shunt configuration



Further details regarding sensing configuration are provided in the next section.

5 Current sensing amplifying network

The STEVAL-IPMNM5Q motor control evaluation board can be configured to run in three-shunt or single-shunt configurations for field oriented control (FOC).

The current can be sensed thanks to the shunt resistor and amplified by using the on-board operational amplifiers or by the MCU (if equipped with op-amp).

Once the shunt configuration is chosen by setting solder bridge on SW5, SW6, SW7 and SW8 (as described in [Section 4.3.4 Single- or three-shunt selection](#)), the user can choose whether to send the voltage shunt to the MCU amplified or not amplified.

Single-shunt configuration requires a single op amp so the only voltage sent to the MCU to control the sensing is connected to phase V through SW2.

SW1, SW2, SW3 and SW17 can be configured to select which signals are sent to the microcontroller, as per the following table.

Table 2. Op-amp sensing configuration

Configuration	Sensing	Bridge (SW1)	Bridge (SW2)	Bridge (SW3)	Bridge (SW17)
Single Shunt	IPM op-amp	open	1-2	open	2-3
	On board op-amp	open	1-2	open	1-2
	MCU op-amp	open	2-3	open	1-2
Three Shunt	On board op-amp	1-2	1-2	1-2	1-2
	MCU op-amp	2-3	2-3	2-3	1-2

The operational amplifier TSV994 used on the amplifying networks has a 20 MHz gain bandwidth from a single positive supply of 3.3 V.

The amplification network must allow bidirectional current sensing, so an output offset $V_O = +1.65$ V represents zero current.

For the STIPQ5M60T-H ($I_{OCP} = 3.9$ A; $R_{SHUNT} = 0.22$ Ω), the maximum measurable phase current, considering that the output swings from +1.65 V to +3.3 V (MCU supply voltage) for positive currents and from +1.65 V to 0 for negative currents is:

$$MaxMeasCurrent = \frac{\Delta V}{r_m} = 3.9A \quad (6)$$

$$r_m = \frac{\Delta V}{MaxMeasCurrent} = \frac{1.65}{3.9} = 0.423\Omega \quad (7)$$

The overall trans-resistance of the two-port network is:

$$r_m = R_{SHUNT} \cdot AMP = 0.22 \cdot AMP = 0.423\Omega \quad (8)$$

$$AMP = \frac{r_m}{R_{SHUNT}} = \frac{0.423}{0.22} = 1.922 \quad (9)$$

Finally choosing $R_a=R_b$ and $R_c=R_d$, the differential gain of the circuit is:

$$AMP = \frac{R_c}{R_d} = 1.9 \quad (10)$$

An amplification gain of 1.9 was chosen. The same amplification is obtained for all the other devices, taking into account the OCP current and the shunt resistance, as described in Table 1.

The RC filter for output amplification is designed to have a time constant that matches noise parameters in the range of 1.5 μ s:

$$4 \cdot \tau = 4 \cdot R_e \cdot C_c = 1.5\mu s \quad (11)$$

$$C_c = \frac{1.5\mu s}{4 \cdot 1000} = 375pF \left(330pF_{selected} \right) \quad (12)$$

Table 3. Amplifying networks

Phase	Amplifying network				RC filter	
	Ra	Rb	Rc	Rd	Re	Cc
Phase A (U)	R21	R23	R20	R24	R22	C25
Phase B (V)	R26	R27	R25	R29	R43	C29
Phase C (W)	R30	R32	R28	R33	R31	C31

6 Temperature monitoring

The SLLIMM-nano MOSFET family integrates an NTC thermistor placed close to the power stage. The board is designed to use it in sharing with the \overline{SD} pin. Monitoring can be enabled and disabled via the SW4 switch.

6.1 NTC Thermistor

The built-in thermistor (85 k Ω at 25 °C) is inside the IPM and connected on \overline{SD} /OD pin2 (shared with the SD function).

Given the NTC characteristic and the sharing with the \overline{SD} function, the network is designed to keep the voltage on this pin higher than the minimum voltage required for the pull up voltage on this pin over the whole temperature range.

Considering $V_{bias} = 3.3$ V, a pull up resistor of 1 k Ω (R10) was used.

The figure below shows the typical voltage on this pin as a function of device temperature.

Figure 12. NTC voltage vs temperature

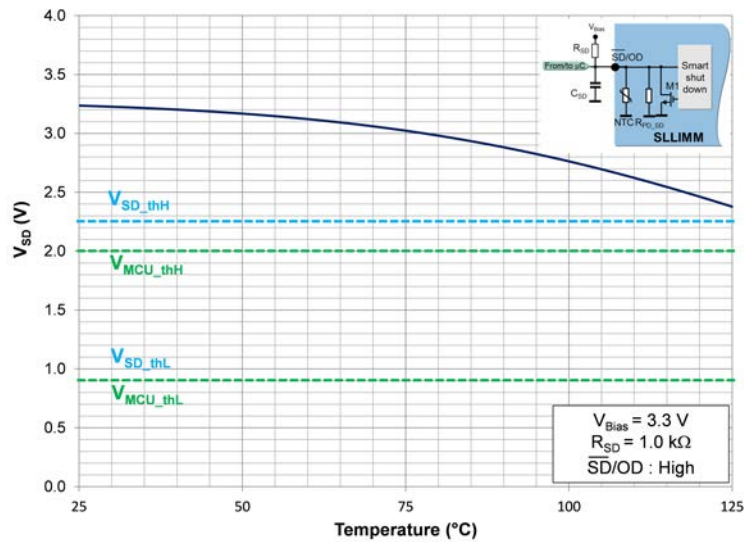

7 Firmware configuration for STM32 PMSM FOC SDK

The following table summarizes the parameters which customize the latest version of the ST FW motor control library for permanent magnet synchronous motors (PMSM): STM32 PMSM FOC SDK for this STEVAL-IPMNM5Q.

Table 4. ST motor control workbench GUI parameters - STEVAL-IPMNM5Q

Block	Parameter	Value
Over current protection	Comparator threshold	$V_{ref} \cdot \left(\frac{R15 + R11}{R11} \right) + V_F = 0.83V \quad (13)$
	Overcurrent network offset	0
	Overcurrent network gain	Comparator threshold / Iocp (see Section 4.3.2 Shunt resistor selection)
Bus voltage sensing	Bus voltage divider	1/125
Rated bus voltage info	Min rated voltage	125 V
	Max rated voltage	400 V
	Nominal voltage	325 V
Current sensing	Current reading typology	Single- or three-shunt
	Shunt resistor value	See Section 4.3.2 Shunt resistor selection
	Amplifying network gain	1.9
Command stage	Phase U Driver	HS and LS: Active high
	Phase V Driver	HS and LS: Active high
	Phase W Driver	HS and LS: Active high

8 Connectors, jumpers and test pins

Table 5. Connectors

Connector	Description / pinout																																		
J1	Supply connector (DC – 125 V to 400 V) <ul style="list-style-type: none"> • Positive + • Negative - 																																		
J2	Motor control connector <table border="1" style="width: 100%; border-collapse: collapse;"> <tbody> <tr> <td>1 - emergency stop</td> <td>2 - GND</td> </tr> <tr> <td>3 - PWM-A-H</td> <td>4 - GND</td> </tr> <tr> <td>5 - PWM-A-L</td> <td>6 - GND</td> </tr> <tr> <td>7 - PWM-B-H</td> <td>8 - GND</td> </tr> <tr> <td>9 - PWM-B-L</td> <td>10 - GND</td> </tr> <tr> <td>11 - PWM-C-H</td> <td>12 - GND</td> </tr> <tr> <td>13 - PWM-C-L</td> <td>14 - HV bus voltage</td> </tr> <tr> <td>15 - current phase A</td> <td>16 - GND</td> </tr> <tr> <td>17 - current phase B</td> <td>18 - GND</td> </tr> <tr> <td>19 - current phase C</td> <td>20 - GND</td> </tr> <tr> <td>21 - NTC bypass relay</td> <td>22 - GND</td> </tr> <tr> <td>23 - dissipative brake PWM</td> <td>24 - GND</td> </tr> <tr> <td>25 - +V power</td> <td>26 - heat sink temperature</td> </tr> <tr> <td>27- PFC sync.</td> <td>28 - VDD_m</td> </tr> <tr> <td>29 - PWM VREF</td> <td>30 - GND</td> </tr> <tr> <td>31 - measure phase A</td> <td>32 - GND</td> </tr> <tr> <td>33 - measure phase B</td> <td>34 - measure phase C</td> </tr> </tbody> </table>	1 - emergency stop	2 - GND	3 - PWM-A-H	4 - GND	5 - PWM-A-L	6 - GND	7 - PWM-B-H	8 - GND	9 - PWM-B-L	10 - GND	11 - PWM-C-H	12 - GND	13 - PWM-C-L	14 - HV bus voltage	15 - current phase A	16 - GND	17 - current phase B	18 - GND	19 - current phase C	20 - GND	21 - NTC bypass relay	22 - GND	23 - dissipative brake PWM	24 - GND	25 - +V power	26 - heat sink temperature	27- PFC sync.	28 - VDD_m	29 - PWM VREF	30 - GND	31 - measure phase A	32 - GND	33 - measure phase B	34 - measure phase C
1 - emergency stop	2 - GND																																		
3 - PWM-A-H	4 - GND																																		
5 - PWM-A-L	6 - GND																																		
7 - PWM-B-H	8 - GND																																		
9 - PWM-B-L	10 - GND																																		
11 - PWM-C-H	12 - GND																																		
13 - PWM-C-L	14 - HV bus voltage																																		
15 - current phase A	16 - GND																																		
17 - current phase B	18 - GND																																		
19 - current phase C	20 - GND																																		
21 - NTC bypass relay	22 - GND																																		
23 - dissipative brake PWM	24 - GND																																		
25 - +V power	26 - heat sink temperature																																		
27- PFC sync.	28 - VDD_m																																		
29 - PWM VREF	30 - GND																																		
31 - measure phase A	32 - GND																																		
33 - measure phase B	34 - measure phase C																																		
J3	Motor connector <ul style="list-style-type: none"> • phase A (U) • phase B (V) • phase C (W) 																																		
J4	VCC supply (20 VDC max) <ul style="list-style-type: none"> • Positive + • Negative - 																																		
J5	Hall sensors / encoder input connector <ol style="list-style-type: none"> 1. Hall sensors input 1 / encoder A+ 2. Hall sensors input 2 / encoder B+ 3. Hall sensors input 3 / encoder Z+ 4. 3.3 or 5 Vdc 5. GND 																																		

Table 6. Jumpers

Jumper	Description	
SW1	Choose current U to send to control board	
	Jumper on 1-2: from amplification	
	Jumper on 2-3: directly from motor output	
SW2	Choose current V to send to control board	
	Jumper on 1-2: from amplification	
	Jumper on 2-3: directly from motor output	
SW3	Choose current W to send to control board	
	Jumper on 1-2: from amplification	
	Jumper on 2-3: directly from motor output	
SW4	Enable or disable sending temperature information from NTC to microcontroller	
SW5, SW6 SW7, SW8	Choose 1-shunt or 3-shunt configuration. (through solder bridge)	
	SW5, SW6 closed	one shunt
	SW7, SW8 open	three shunt
SW9, SW16	Choose input power for Hall/Encoder	
	Jumper on 1-2: 5 V	
	Jumper on 2-3: 3.3 V	
SW10, SW13	Modify phase A hall sensor network	
SW11, SW14	Modify phase B hall sensor network	
SW12, SW15	Modify phase C hall sensor network	
SW17	Choose on-board or IPM op-amp in one shunt configuration	
	Jumper on 1-2: on-board op-amp	
	Jumper on 2-3: IPM op-amp	

Table 7. Test pins

Test Pin	Description
TP1	OUTW
TP2	HINW (high side W control signal input)
TP3	VccW
TP4	SD (shutdown pin)/NTC
TP5	LINW (high side W control signal input)
TP6	OP+
TP7	OPOUT
TP8	OP
TP9	VbootW
TP10	OUTV
TP11	NV
TP12	HINV (high side V control signal input)
TP13	VbootV
TP14	LINV (high side V control signal input)
TP15	CIN
TP16	NU
TP17	NW
TP18	OUTU
TP19	VbootU
TP20	LINU (high side U control signal input)
TP21	Ground
TP22	Ground
TP23	HinU (high side U control signal input)
TP24	Current_A_amp
TP25	Current_B_amp
TP26	Current_C_amp
TP27	Ground

9 Bill of materials

Table 8. STEVAL-IPMNM5Q bill of materials

Item	Q.ty	Ref.	Part / Value	Description	Manufacturer	Order code
1	-	C1	330μF	CPCYL_D1400	EPCOS	B43501A9337M000
2	4	C2, C22, C26, C28	10nF	1206	AVX	12065C103KAT2A
3	2	C3, C4	47μF	PTH 2-pin	any	any
4	3	C5, C6, C7	2.2μF	1206	Murata	GCM31MR71E225KA57L
5	1	C8	1nF	1206	Kemet	C1206C102K5RACTU
6	1	C12	10μF	PTH 2-pin	any	any
7	9	C10, C11, C14, C15, C16, C19, C35, C36, C37	10pF	1206	AVX	12061A100JAT2A
8	1	C17	0.1μF	1812	Murata	GRM43DR72J104KW01L
9	1	C18	3.3nF	1206	Kemet	C1206C332K5RACTU
10	1	C21	4.7μF	PTH 2-pin	any	any
11	3	C24, C27, C30	100pF	1206	Kemet	C1206C101J1GACTU
12	3	C25, C29, C31	330pF	1206	AVX	12065A331JAT2A
13	5	C13, C23, C32, C33, C34	100nF	1206	AVX	12065C104KAZ2A
14	5	D1, D3, D4, D5, D10	Diode BAT48J	SOD323	ST	BAT48J
15	1	D2	LED Red	PTH 2-pin	Ledtech	L4RR3000G1EP4
16	4	D6, D7, D8, D9	Diode ZENER	SOD123	Fairchild Semiconduct or	MMSZ5250B
17	1	J1	Conector 7.62 mm - 2P	PTH 2-pin p.7,62mm	TE Connectivity AMP Connectors	282845-2
18	1	J2	Connector 34P	PTH 34-pin	RS	-
19	1	J3	Connector 7.62 mm - 3P	PTH 3-pin p.7,62mm	TE Connectivity AMP Connectors	282845-3

Item	Q.ty	Ref.	Part / Value	Description	Manufacturer	Order code
20	1	J4	Conector 5 mm - 2P	PTH 2-pin p.5mm	Phoenix Contact	1729128
21	1	J5	Connector 2.54 mm - 5P	PTH 5-pin p.2,54mm	RS	W81136T3825RC
22	2	R1, R2	470kΩ	1206	any	any
23	1	R3	120 Ω	1206	any	any
24	1	R4	7.5kΩ	1206	Panasonic	ERJP08F7501V
25	19	R5, R6, R7, R8, R9, R10, R13, R14, R15, R19, R21, R22, R23, R26, R27, R30, R31, R32, R43	1kΩ	1206	any	any
26	1	R12	5.6kΩ	1206	any	any
27	3	R16, R17, R18	0.22Ω	2512	Panasonic	ERJ1TRQFR33U
28	6	R20, R24, R25, R28, R29, R33	1.91kΩ	1206	Panasonic	ERJ8ENF1911V
29	3	R37, R38, R39	2.4kΩ	1206	any	any
30	7	R11, R34, R35, R36, R40, R41, R42	4.7kΩ	1206	any	any
31	3	RC2, RC5, RC14	0 Ω	0805	any	any
32	-	RC1, RC3, RC4, RC6, RC7, RC8, RC9, RC10, RC11, RC12, RC13	-	Not mounted	-	-
33	2	SW7, SW8	Solder Bridge	SMD	-	-
34	2	SW5, SW6	open	SMD	-	-
35	6	SW1, SW2, SW3, SW9,	Jumper 2.54	PTH 3-pin	RS	W81136T3825RC

Item	Q.ty	Ref.	Part / Value	Description	Manufacturer	Order code
		SW16, SW17				
36	7	SW4, SW10, SW11, SW12, SW13, SW14, SW15	Jumper 2.54	PTH 2-pin	RS	W81136T3825RC
37	26	TP1, TP2, TP3, TP4, TP5, TP6, TP7, TP8, TP9, TP10, TP11, TP12, TP13, TP14, TP15, TP16, TP17, TP18, TP19, TP20, TP22, TP23, TP24, TP25, TP26, TP27	PCB terminal 1mm	PTH 1-pin	KEYSTONE	5001
38	1	TP21	PCB terminal 12.7mm	PTH 2-pin	HARWIN	D3083B-46
39	10	to close SWxy	Jumper female straight, black, 2-way, 2.54mm	Jumper	TE Connectivity	881545-2
40	1	U1	TSV994IDT	SO14	ST	TSV994
41	1	U2	STIPQ5M60T-H	PTH 26-pin	ST	STIPQ5M60T-HL

10 PCB design guide

Optimization of PCB layout for high voltage, high current and high switching frequency applications is a critical point. PCB layout is a complex matter as it includes several aspects, such as length and width of track and circuit areas, but also the proper routing of the traces and the optimized reciprocal arrangement of the various system elements in the PCB area.

A good layout can help the application to properly function and achieve expected performance. On the other hand, a PCB without a careful layout can generate EMI issues, provide overvoltage spikes due to parasitic inductance along the PCB traces and produce higher power loss and even malfunction in the control and sensing stages.

In general, these conditions were applied during the design of the board:

- PCB traces designed as short as possible and the area of the circuit (power or signal) minimized to avoid the sensitivity of such structures to surrounding noise
- Good distance between switching lines with high voltage transitions and the signal line sensitive to electrical noise
- The shunt resistors were placed as close as possible to the low side pins of the SLLIMM. To decrease the parasitic inductance, a low inductance type resistor was used
- RC filters were placed as close as possible to the SLLIMM pins in order to increase their efficiency

10.1 Layout of reference board

All the components are inserted on the top of the board. Only the IPM module is inserted on the bottom to allow the insertion of a suitable heatsink for the application.

Figure 13. Silk screen and etch - top side

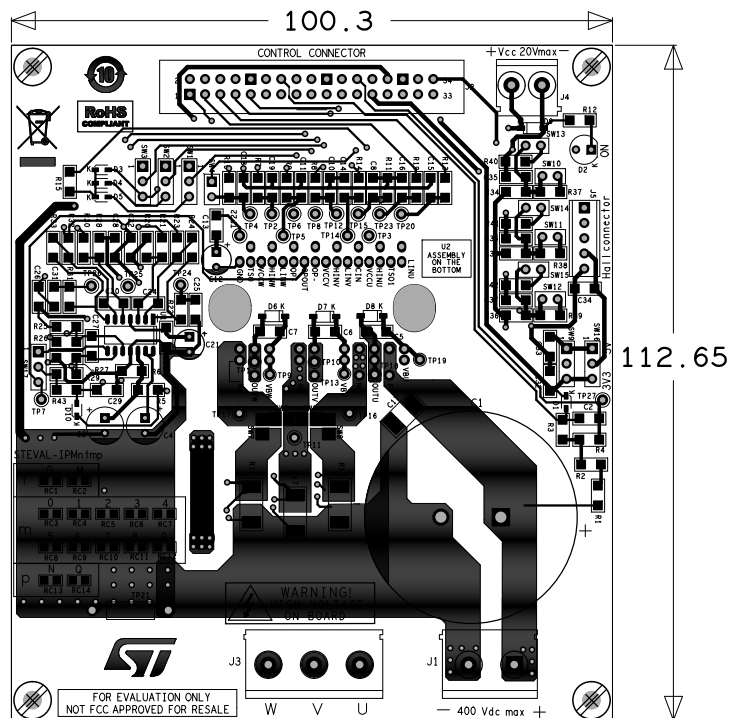
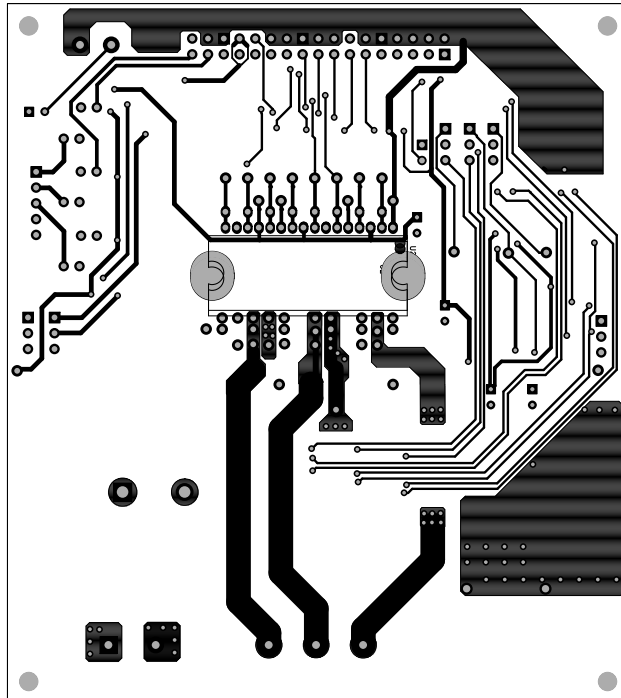

Figure 14. Silk screen and etch - bottom side



11 Recommendations and suggestions

- The BOM list is not provided with a bulk capacitor already inserted in the PCB. However, the necessary space has been included (C1). In order to obtain a stable supply voltage, according to the application conditions and current ripple requirements, it's advisable to use an adequate bulk capacitor. For general motor control applications, an electrolytic capacitor of at least 100 μF is suggested
- Similarly, the PCB does not come with a heat sink, it can be placed above the IPM on the back of the PCB with thermal conductive foil and screws. Heat sink R_{TH} value is an important factor for good thermal performance and depends on certain factors such as current phase, switching frequency, power factor and ambient temperature.
- For an adequate heat sink dimensioning, it is suggested to use ST PowerStudio software (STSW-POWERSTUDIO), available on www.st.com.
- The board requires +5 V and +3.3 V to be supplied externally through the 34-pin motor control connector J2. Please refer to the relevant board manuals for information on key connections and supplies.

12 General safety instructions

Danger:

The evaluation board works with high voltage which could be deadly for the users. Furthermore all circuits on the board are not isolated from the line input. Due to the high power density, the components on the board as well as the heat sink can be heated to a very high temperature, which can cause a burning risk when touched directly. This board is intended for use by experienced power electronics professionals who understand the precautions that must be taken to ensure that no danger or risk may occur while operating this board.

Caution: After the operation of the evaluation board, the bulk capacitor C1 (if used) may still store a high energy for several minutes. So it must be first discharged before any direct touching of the board.

Important:

To protect the bulk capacitor C1, we strongly recommended using an external brake chopper after C1 (to discharge the high brake current back from the induction motor).

Revision history

Table 9. Document revision history

Date	Version	Changes
07-Apr-2020	1	Initial release.

Contents

1	Key features	2
2	Circuit schematics	3
2.1	Schematic diagrams	4
3	Main characteristics	9
4	Filters and key parameters	10
4.1	Input signals	10
4.2	Bootstrap capacitor	10
4.3	Overcurrent protection	10
4.3.1	SD pin	11
4.3.2	Shunt resistor selection	11
4.3.3	CIN RC filter	11
4.3.4	Single- or three-shunt selection	12
5	Current sensing amplifying network	13
6	Temperature monitoring	15
6.1	NTC Thermistor	15
7	Firmware configuration for STM32 PMSM FOC SDK	16
8	Connectors, jumpers and test pins	17
9	Bill of materials	20
10	PCB design guide	23
10.1	Layout of reference board	23
11	Recommendations and suggestions	25
12	General safety instructions	26
	Revision history	27
	Contents	28
	List of tables	29
	List of figures	30

List of tables

Table 1.	Shunt selection	11
Table 2.	Op-amp sensing configuration	13
Table 3.	Amplifying networks	14
Table 4.	ST motor control workbench GUI parameters - STEVAL-IPMNM5Q	16
Table 5.	Connectors	17
Table 6.	Jumpers	18
Table 7.	Test pins	19
Table 8.	STEVAL-IPMNM5Q bill of materials	20
Table 9.	Document revision history	27

List of figures

Figure 1.	Motor control board based on SLIMM-nano 2nd series - top view	1
Figure 2.	Motor control board based on SLIMM-nano 2nd series - bottom view.	1
Figure 3.	STEVAL-IPMNM5Q board schematic (1 of 5)	4
Figure 4.	STEVAL-IPMNM5Q board schematic (2 of 5)	5
Figure 5.	STEVAL-IPMNM5Q board schematic (3 of 5)	6
Figure 6.	STEVAL-IPMNM5Q board schematic (4 of 5)	7
Figure 7.	STEVAL-IPMNM5Q board schematic (5 of 5)	8
Figure 8.	STEVAL-IPMNM5Q architecture	9
Figure 9.	CBOOT graph selection	10
Figure 10.	One-shunt configuration.	12
Figure 11.	Three-shunt configuration	12
Figure 12.	NTC voltage vs temperature.	15
Figure 13.	Silk screen and etch - top side	23
Figure 14.	Silk screen and etch - bottom side.	24

IMPORTANT NOTICE – PLEASE READ CAREFULLY

STMicroelectronics NV and its subsidiaries (“ST”) reserve the right to make changes, corrections, enhancements, modifications, and improvements to ST products and/or to this document at any time without notice. Purchasers should obtain the latest relevant information on ST products before placing orders. ST products are sold pursuant to ST’s terms and conditions of sale in place at the time of order acknowledgement.

Purchasers are solely responsible for the choice, selection, and use of ST products and ST assumes no liability for application assistance or the design of Purchasers’ products.

No license, express or implied, to any intellectual property right is granted by ST herein.

Resale of ST products with provisions different from the information set forth herein shall void any warranty granted by ST for such product.

ST and the ST logo are trademarks of ST. For additional information about ST trademarks, please refer to www.st.com/trademarks. All other product or service names are the property of their respective owners.

Information in this document supersedes and replaces information previously supplied in any prior versions of this document.

© 2020 STMicroelectronics – All rights reserved