



CEC (consumer electronic control) C library using the STM32F101xx, STM32F102xx and STM32F103xx microcontrollers

Introduction

This user manual describes the CEC library using the STM32F10xxx microcontroller family. Consumer electronic control (CEC) is a feature of the HDMI interface 1.3 standard (high definition multimedia interface), which is used to transmit audio/video data for multimedia consumer products such as HDTV, DVDs, satellite receivers etc.

This library contains the following functions for a basic CEC communication:

- Send/Receive CEC Start bit
- Send/Receive CEC ACK bit “logical 0”
- Send/Receive CEC data bit
- Send/Receive CEC data byte
- Send/Receive CEC data frame

Note that the provided CEC library supports only messages addressed to a single device and not broadcast messages (please refer to HDMI - CEC specification).

Contents

- 1 CEC library description 6**
- 2 CEC communication 7**
 - 2.1 CEC frame 7
 - 2.2 Hardware considerations 7
- 3 CEC library functions 8**
 - 3.1 CEC low level functions 8
 - 3.1.1 CEC_Init function 8
 - 3.1.2 CEC_NVIC_Configuration function 8
 - 3.1.3 CEC_Wait100us function 9
 - 3.1.4 CEC_TimingDelay_Decrement function 9
 - 3.2 CEC medium level functions 10
 - 3.2.1 CEC_SendStartBit function 10
 - 3.2.2 CEC_ReceiveStartBit function 10
 - 3.2.3 CEC_SendAckBit function 11
 - 3.2.4 CEC_ReceiveAckBit function 11
 - 3.2.5 CEC_SendDataBit function 12
 - 3.2.6 CEC_ReceiveDataBit function 12
 - 3.2.7 CEC_SendByte function 13
 - 3.2.8 CEC_ReceiveByte function 14
 - 3.3 CEC high level functions 14
 - 3.3.1 CEC_SendFrame function 14
 - 3.3.2 CEC_ReceiveFrame function 15
- 4 How to run the CEC demo 18**
 - 4.1 Example of hardware connections between the three evaluation boards 18
 - 4.2 CEC demo guidelines 18
 - 4.3 CEC send/receive information display on the LCD 19
 - 4.4 Send subscreen information 19
 - 4.5 Receive subscreen information 20
- 5 Conclusion 21**

6 Revision history 22

List of tables

Table 1.	STM32F10xxx CEC library functions	6
Table 2.	CEC_Init function	8
Table 3.	CEC_NVIC_Configuration function	9
Table 4.	CEC_Wait100us function	9
Table 5.	CEC_TimingDelay_Decrement function	9
Table 6.	CEC_SendStartBit function	10
Table 7.	CEC_ReceiveStartBit function	10
Table 8.	CEC_SendAckBit function	11
Table 9.	CEC_ReceiveAckBit function	11
Table 10.	CEC_SendDataBit function	12
Table 11.	CEC_ReceiveDataBit function	12
Table 12.	CEC_SendByte function	13
Table 13.	CEC_ReceiveByte function	14
Table 14.	CEC_SendFrame function	14
Table 15.	CEC_ReceiveFrame function	15
Table 16.	Document revision history	22

List of figures

Figure 1.	CEC frame	7
Figure 2.	CEC Hardware requirement	7
Figure 3.	Receive start bit flowchart.	11
Figure 4.	Receive data bit flowchart.	13
Figure 5.	CEC connections between the three STM3210B-EVAL boards.	18
Figure 6.	LCD screenshot after reset.	19
Figure 7.	LCD screenshot of a successful send transaction	19
Figure 8.	LCD screen shot of a failed send transaction	20
Figure 9.	LCD screenshot of a successful receive transaction	20
Figure 10.	LCD screenshot of a detected frame	20
Figure 11.	LCD screenshot of a failed receive transaction	20

1 CEC library description

The STM32F10xxx CEClib is a set of common functions for CEC communication. It includes the following functions:

Table 1. STM32F10xxx CEC library functions

Function name	Description
CEC_Init	CEC initialization
CEC_NVIC_Configuration	CEC NVIC configuration
CEC_Wait100us	CEC timing for send/receive a CEC bit
CEC_TimingDelay_Decrement	CEC time base generation
CEC_SendStartBit	CEC send start bit
CEC_ReceiveStartBit	CEC receive start bit
CEC_SendAckBit	CEC send acknowledge bit
CEC_ReceiveAckBit	CEC receive acknowledge bit
CEC_SendDataBit	CEC send data bit
CEC_ReceiveDataBit	CEC receive data bit
CEC_SendByte	CEC send data byte
CEC_ReceiveByte	CEC receive data byte
CEC_SendFrame	CEC send data frame
CEC_ReceiveFrame	CEC receive data frame

2 CEC communication

2.1 CEC frame

The CEC bus is a single-wire protocol that can connect up to 10 audiovisual devices through standard HDMI cabling.

The CEC transaction is made up of a start bit, a 10-bit header and a sequence of n 10-bit data blocks. The Header block and the Data blocks each contain an end-of-message (EOM) bit and an acknowledge (ACK) bit. *Figure 1* shows a CEC frame format.

Figure 1. CEC frame

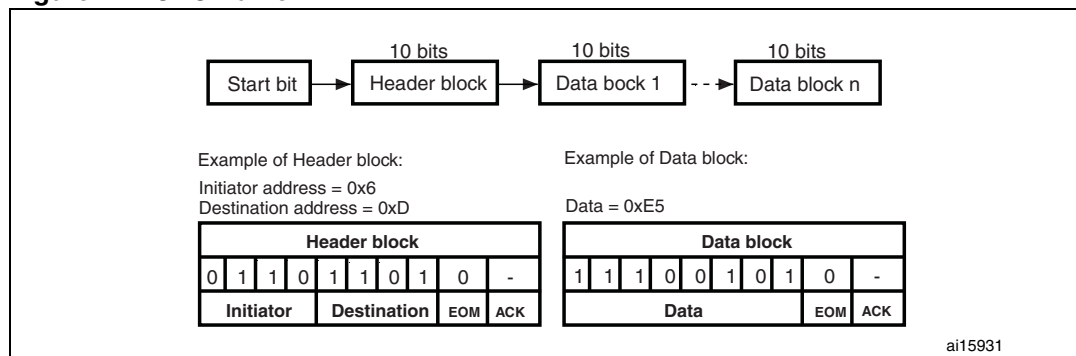

A Header block is a sequence of 10 bits: the 4-bit logical address of the Initiator, the 4-bit logical address of the Destination, the end-of-message (EOM) bit and the Acknowledge (ACK) bit.

A Data block is a sequence of 10 bits: an 8-bit field that represents the opcode or the operand, the end-of-message (EOM) bit and the Acknowledge (ACK) bit. The HDMI standard defines the opcodes and the possible number of operands for each message.

2.2 Hardware considerations

The physical connection to the HDMI network is straightforward. In accordance with the CEC specification, the CEC pin of the HDMI connector has to be pulled up to a 3.3 V supply voltage via a 27 kΩ resistor (refer to *Figure 2*).

Figure 2. CEC Hardware requirement

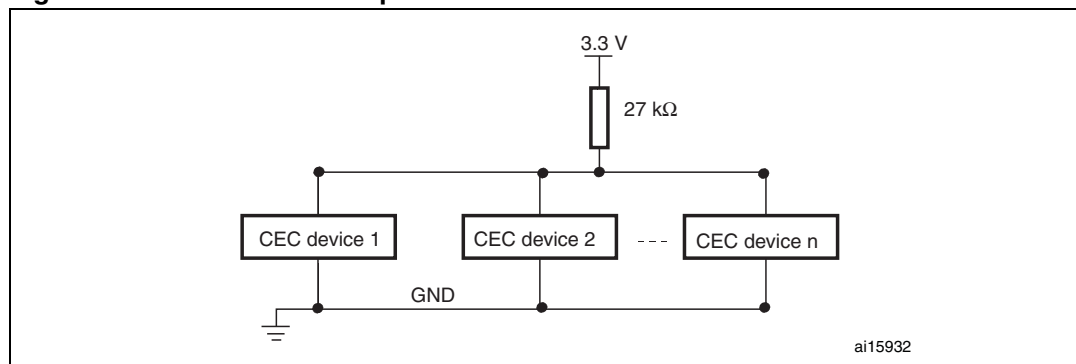

3 CEC library functions

The CEC library provides three types of functions:

- **Low level functions:** functions that initialize and configure peripherals to be ready for CEC communication.
- **Medium level functions:** functions doing elementary CEC routines.
- **High level functions:** functions sending/receiving CEC frames.

3.1 CEC low level functions

3.1.1 CEC_Init function

[Table 2](#) describes the CEC_Init function.

Table 2. CEC_Init function

Function name	CEC_Init
Prototype	void CEC_Init(void)
Behavior description	Initializes the GPIO, system tick, NVIC and EXTI to communicate with the CEC protocol
Input parameter	None
Output parameter	None
Return parameter	None
Required preconditions	The software has to configure the different clocks and the NVIC vector table base before calling this function.

Example

```
int main(void)
{
  /* RCC configuration */
  RCC_Configuration();

  /* NVIC configuration */
  NVIC_Configuration();

  /* CEC initialization */
  CEC_Init();
  ....
  ....
}
```

3.1.2 CEC_NVIC_Configuration function

[Table 3](#) describes the CEC_NVIC_Configuration function.

Table 3. CEC_NVIC_Configuration function

Function name	CEC_NVIC_Configuration
Prototype	void CEC_NVIC_Configuration(void)
Behavior description	Configures global interrupts of SystemTick and EXTI
Input parameter	None
Output parameter	None
Return parameter	None
Required preconditions	The SystemTick and EXTI global interrupt priorities used in the CEC library have to have the highest interrupt level in the application.

The used and reserved NVIC configurations for the CEC library are:

SystemTick: Preemption priority = 1, subpriority = 1

EXTI0: Preemption priority = 2, subpriority = 1

3.1.3 CEC_Wait100us function

[Table 4](#) describes the CEC_Init function.

Table 4. CEC_Wait100us function

Function name	CEC_Wait100us
Prototype	void CEC_Wait100us(__IO uint32_t nTime)
Behavior description	Insert a delay in 100 μ s unit.
Input parameter	nTime is the number of 100 μ s units to be inserted. Delay = 100 μ s \times nTime
Output parameter	None
Return parameter	None
Required preconditions	None

3.1.4 CEC_TimingDelay_Decrement function

[Table 5](#) describes the CEC_TimingDelay_Decrement function.

Table 5. CEC_TimingDelay_Decrement function

Function name	CEC_TimingDelay_Decrement
Prototype	void CEC_TimingDelay_Decrement(void)
Behavior description	Decrements the TimingDelay variable in the SysTick interrupt
Input parameter	None
Output parameter	None
Return parameter	None
Required preconditions	None

3.2 CEC medium level functions

3.2.1 CEC_SendStartBit function

[Table 6](#) describes the CEC_SendStartBit function.

Table 6. CEC_SendStartBit function

Function name	CEC_SendStartBit
Prototype	void CEC_SendStartBit(void)
Behavior description	Sends the CEC start bit.
Input parameter	None
Output parameter	None
Return parameter	None
Required preconditions	None

3.2.2 CEC_ReceiveStartBit function

[Table 7](#) describes the CEC_ReceiveStartBit function.

Table 7. CEC_ReceiveStartBit function

Function name	CEC_ReceiveStartBit
Prototype	uint8_t CEC_ReceiveStartBit(void)
Behavior description	Receives the CEC start bit.
Input parameter	None
Output parameter	None
Return parameter	a uint8_t integer: 1: if the CEC start bit has been received correctly 0: if the CEC start bit has not been received correctly
Required preconditions	None

Figure 3. Receive start bit flowchart

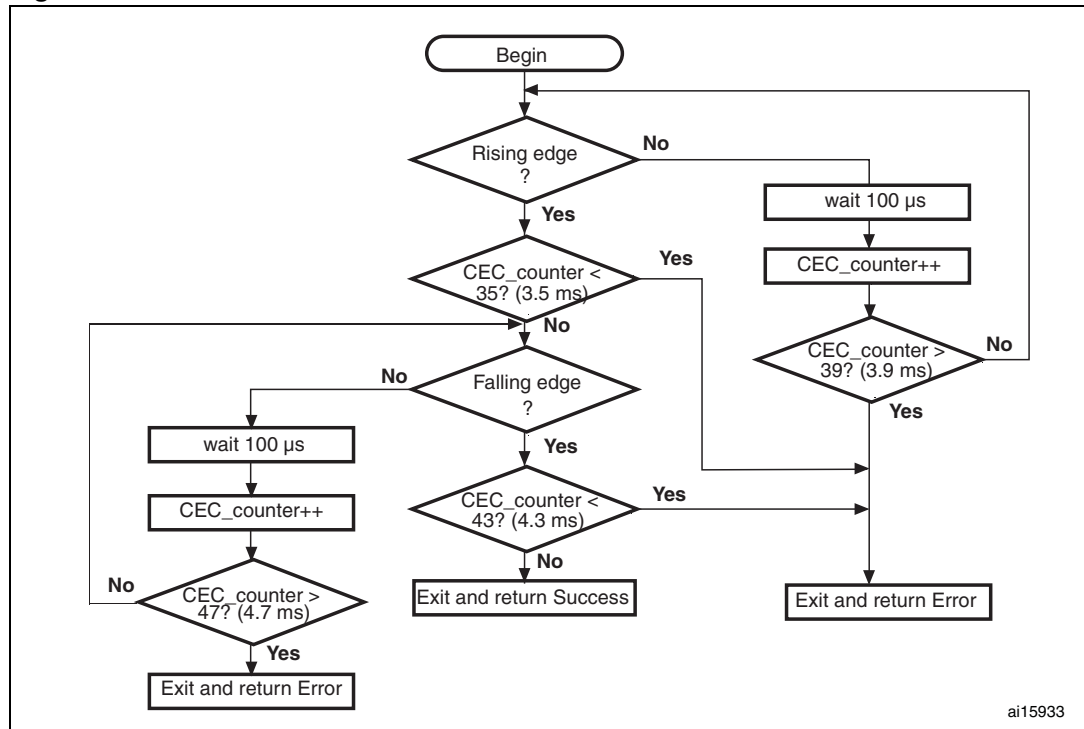

3.2.3 CEC_SendAckBit function

Table 8 describes the CEC_SendAckBit function.

Table 8. CEC_SendAckBit function

Function name	CEC_SendAckBit
Prototype	void CEC_SendAckBit(void)
Behavior description	Sends the CEC ACK bit (ACK = logical 0)
Input parameter	None
Output parameter	None
Return parameter	None
Required preconditions	None

3.2.4 CEC_ReceiveAckBit function

Table 9 describes the CEC_ReceiveAckBit function.

Table 9. CEC_ReceiveAckBit function

Function name	CEC_ReceiveAckBit
Prototype	uint8_t CEC_ReceiveAckBit(void)
Behavior description	Receives the CEC ACK bit
Input parameter	None

Table 9. CEC_ReceiveAckBit function (continued)

Function name	CEC_ReceiveAckBit
Output parameter	None
Return parameter	a uint8_t integer: 0: receive ACK bit succeeded 0xFF: receive ACK bit failed
Required preconditions	None

3.2.5 CEC_SendDataBit function

[Table 10](#) describes the CEC_SendDataBit function.

Table 10. CEC_SendDataBit function

Function name	CEC_SendDataBit
Prototype	void CEC_SendDataBit(uint8_t bit)
Behavior description	Receives the CEC ACK bit (ACK = logical 0)
Input parameter	None
Output parameter	None
Return parameter	a uint8_t integer: 0: receive ACK bit succeeded 0xFF: receive ACK failed
Required preconditions	None

3.2.6 CEC_ReceiveDataBit function

[Table 11](#) describes the CEC_ReceiveDataBit function.

Table 11. CEC_ReceiveDataBit function

Function name	CEC_ReceiveDataBit
Prototype	uint8_t CEC_ReceiveDataBit(void)
Behavior description	Receives a CEC data bit.
Input parameter	None
Output parameter	None
Return parameter	The received data bit as a uint8_t integer: 1: if the data bit received was logical 1 0: if the data bit received was logical 0 0xFF: if the data bit has not been received correctly
Required preconditions	None

Figure 4. Receive data bit flowchart

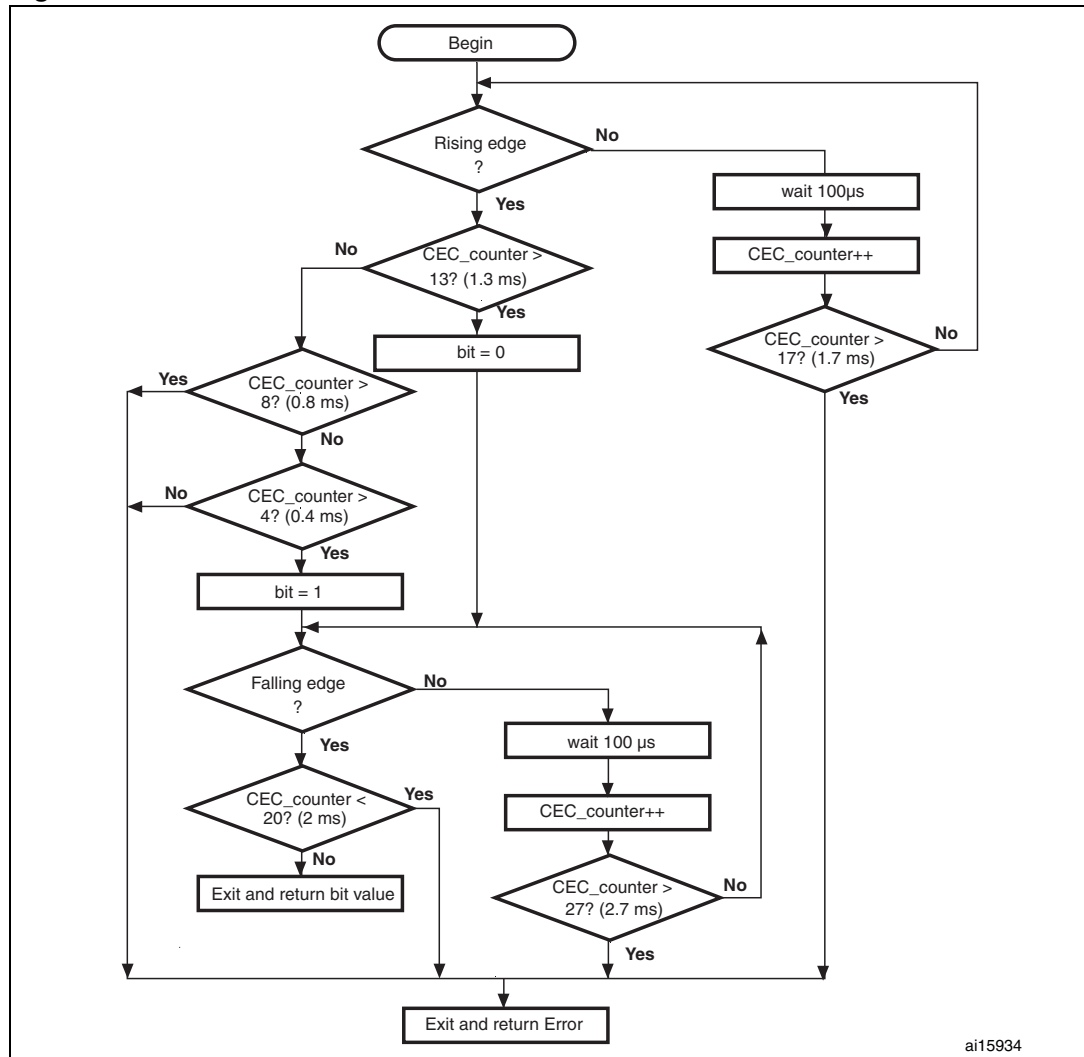

ai15934

3.2.7 CEC_SendByte function

Table 12 describes the CEC_SendByte function.

Table 12. CEC_SendByte function

Function name	CEC_SendByte
Prototype	ErrorStatus CEC_SendByte(uint8_t byte)
Behavior description	Sends a CEC Header or Data block
Input parameter	byte: the CEC opcode or operand to be transmitted
Output parameter	None
Return parameter	The status of the Header/Data block transmission: SUCCESS: CEC byte was acknowledged by the destination ERROR: CEC byte wasn't acknowledged by the destination
Required preconditions	None

3.2.8 CEC_ReceiveByte function

Table 13 describes the CEC_ReceiveByte function.

Table 13. CEC_ReceiveByte function

Function name	CEC_ReceiveByte
Prototype	uint8_t CEC_ReceiveByte(uint8_t HeaderDataIndicator)
Behavior description	Receives a CEC Header or Data block
Input parameter	HeaderDataIndicator: indicates if the byte to receive is a Header or Data block. It can be: HeaderBlock: for the Header block reception DataBlock: for the Data block reception
Output parameter	None
Return parameter	The received byte
Required preconditions	None

3.3 CEC high level functions

3.3.1 CEC_SendFrame function

Table 14 describes the CEC_SendFrame function.

Table 14. CEC_SendFrame function

Function name	CEC_SendFrame
Prototype	ErrorStatus CEC_SendFrame(uint8_t InitiatorAddress, uint8_t FollowerAddress, uint8_t MessageLength, uint8_t* Message)
Behavior description	Sends a CEC frame.
Input parameter	– InitiatorAddress: the initiator address: from 0 to 15 – FollowerAddress: the destination address: from 0 to 15 – MessageLength: the number of data bytes to send – Message: a pointer to the transmit buffer
Output parameter	None
Return parameter	The status of the CEC frame transmission: SUCCESS: If the destination received the full frame correctly ERROR: the destination does not receive the full frame correctly
Required preconditions	None

Example

```
#define MyDeviceAddress 0x6 /* My device address*/
#define FollowerAddress 0xF /* Follower address to send the frame */
uint8_t NumberOfTransmitAttempt = 5;
```

```
uint8_t
TransmitBuffer[10]={0xdf,0x12,0xd3,0x56,0x97,0xa1,0xec,0x7b,0x4f,0x
22};
ErrorStatus SendStatus = ERROR;

/* Send the CEC frame */
do
{
SendStatus = CEC_SendFrame(MyDeviceAddress, FollowerAddress, 10,
TransmitBuffer);
waitOneSecond();
NumberOfTransmitAttempt--;
}
while ((SendStatus != SUCCESS) || (!NumberOfTransmitAttempt));
```

3.3.2 CEC_ReceiveFrame function

Table 15 describes the CEC_ReceiveFrame function.

Table 15. CEC_ReceiveFrame function

Function name	CEC_ReceiveFrame
Prototype	uint32_t CEC_ReceiveFrame(uint8_t* Message, uint8_t FollLogAdd)
Behavior description	Receives a CEC frame
Input parameter	– Message: a pointer to the receive buffer – FollLogAdd: the device address that will receive the frame: from 0 to 15
Output parameter	None
Return parameter	a uint32_t integer that contains some receive information (see below)
Required preconditions	Called by the EXTI interrupt routine

The contents of the uint32_t integer containing the CEC receive frame information returned by CEC_ReceiveFrame function are:

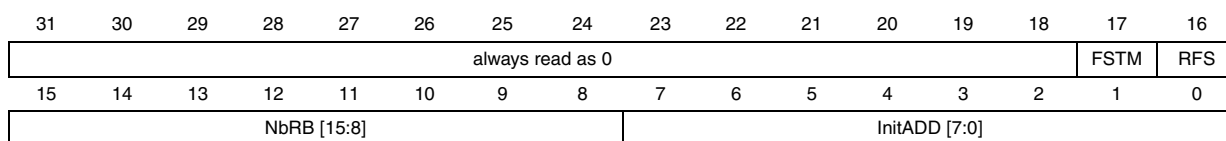

Bits 31:18 always read as 0.

Bit 17 **FSTM**: Frame sent to me

- 0: If the received frame does not have the same destination address
- 1: If the received frame has the same destination address

Bit 16 **RFS**: Receive frame status

- 0: The frame was not received correctly
- 1: The frame was received correctly

Bits 15:8 **NbRB**: Number of received bytes

This field contains the number of received data blocks.

Bits 7:0 **InitADD**: Initiator address

This field contains the frame sender address.

The FSTM, RFS and Initiator address masks are provided in the *stm32f10x_cec.h* file to check their status:

```
#define ReceiveFrameStatusMask 0x00010000
#define FrameSendToMeMask     0x00020000
#define InitiatorAddressMask   0x000000FF
```

Example

- **In the *stm32f10x.it.c* file**

```
#define MyDeviceAddress 0x6 /* My device address*/

/* Private variables -----
-----*/
uint8_t ReceiveBuffer[10];
uint8_t ReceivedFrame = 0;
uint32_t ReceiveFrameInfos = 0;

/* Send the CEC frame */
void EXTI0_IRQHandler(void)
{
    if(EXTI_GetITStatus(EXTI_Line0) != RESET)
    {
        /* Receive the CEC frame with my CEC address */
        ReceiveFrameInfos = CEC_ReceiveFrame(ReceiveBuffer,
MyDeviceAddress);
        /* Set ReceivedFrame software flag to say that a frame was
detected on the bus */
        ReceivedFrame = 1;
        /* Clear EXTI line 0 pending bit */
        EXTI_ClearITPendingBit(EXTI_Line0);
    }
}
```

- **In the *main.c* file**

```
#include <stdio.h>
/* Private variables -----
-----*/
extern uint8_t ReceiveBuffer[10];
extern uint8_t ReceivedFrame;
extern uint32_t ReceiveFrameInfos;
uint8_t NbOfReceivedBytes = 0;

/* If a frame has been received */
if (ReceivedFrame)
{
    /* Check if the frame has been received correctly */
    if (ReceiveFrameInfos & ReceiveFrameStatusMask)
    {
        /* Check if the frame has been send to me */
        if (ReceiveFrameInfos & FrameSendToMeMask)
```



```
    {
        /* Glow the green LED */
        GlowGreenLED();
        /* Get the number of received bytes */
        NbOfReceivedBytes = (uint8_t) (ReceiveFrameInfos >> 8);
        /* Get the initiator address */
        InitiatorAddress = (uint8_t) (ReceiveFrameInfos &
InitiatorAddressMask);
        printf("Initiator Address: %x\n", InitiatorAddress);
        printf("Received data Frame: ", InitiatorAddress);
        for(i=0;i<NbOfReceivedBytes;i++)
        {
            /* Display the received frame */
            printf("%x ",ReceiveBuffer[i] );
        }
    }
    else /* The receive was successful, but I'm not the concerned
destination */
    {
        /* Glow the yellow LED */
        GlowYellowLED();
    }
}
else /* The receive was failed */
{
    /* Glow the red LED */
    GlowRedLED();
}
}
ReceivedFrame=0;
}
```

4 How to run the CEC demo

The demo provided with this user manual is intended to run on three STM3210B-EVAL evaluation boards. It can be run on only two boards but, in this case, the send to the third device is not achieved (refer to [Figure 8](#)).

The demo runs at 72 MHz. The CPU load for the 10-byte CEC receive or send frames over 15 seconds will be of around 2%.

4.1 Example of hardware connections between the three evaluation boards

To run the CEC demo you have to connect the three evaluation boards as shown in [Figure 5](#). That is, you have to connect the board grounds together, then all the PA0 pins together (they constitute the CEC bus). Finally, you have to connect a pull-up resistor (27 kΩ) between the CEC bus and the 3.3 V power supply. The latter can be provided by any of the boards.

Figure 5. CEC connections between the three STM3210B-EVAL boards

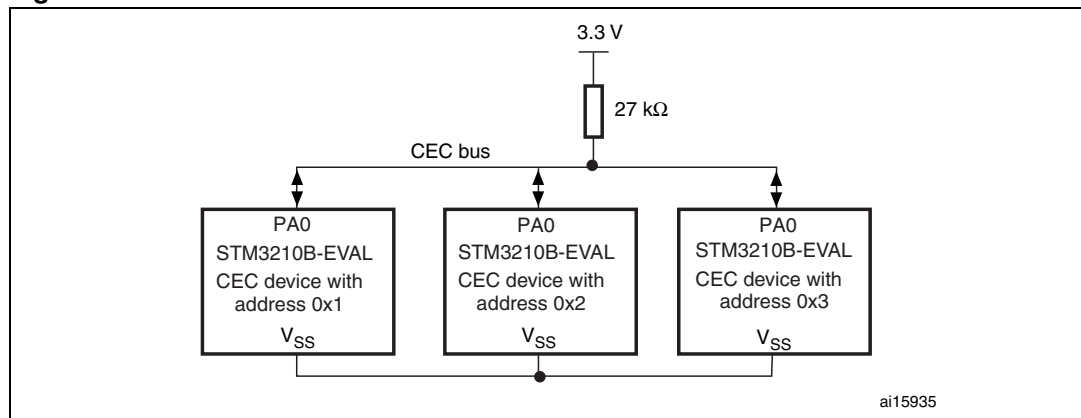

4.2 CEC demo guidelines

There are three folders in the CEC_Demo folder: 1st_CEC_Device, 2nd_CEC_Device and 3rd_CEC_Device.

Each folder contains the project of a device that should be compiled and loaded into one board. If only two boards are available, compile and load any pair (1st_Device, 2nd_Device), (1st_Device, 3rd_Device) or (2nd_Device, 3rd_Device) to the first board and the second board, respectively. Run the demo on each board and the LCD display shown in [Figure 6](#) will appear.

Begin the send/receive transactions by pressing the “key” button on any board.

Example: if you are pressing the key button on the board with the address 0x1 (1st_Device), this board will send a frame to the board with the address 0x2 (2nd_Device). The next time you press on the “key” button, another frame will be sent to the board with the address 0x3 (3rd_Device).

For more details refer to sections 4.3 and section 4.4.

If you are using another type of board, you can show the send/receive frame on the toolchain live watch.

By default, the GPIO pin used for the CEC configuration is PA0. You can use another GPIO pin by modifying some configuration in the CEC library: the used GPIO, the GPIO that generates the EXTI interrupt and the NVIC IRQ channel. You also have to call the CEC_ReceiveFrame function in the appropriate EXTI interrupt routine.

4.3 CEC send/receive information display on the LCD

The LCD screen is divided into two parts:

- a subscreen that shows the CEC receive information
- a subscreen that shows the CEC send information

After reset, each board displays the screen shown in Figure 6.

Figure 6. LCD screenshot after reset

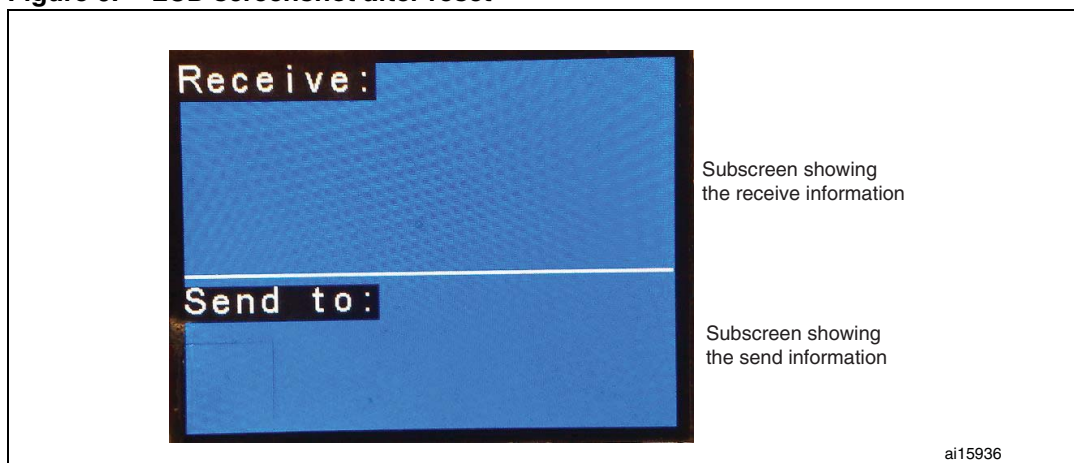

4.4 Send subscreen information

Figure 7 shows that the frame was received without error by the device with address 0x1. The receiver has acknowledged the frame (0x25,0x36,0x79,0xDF,0xA1,0xBD, 0xEC, 0xAB, 0xFD, 0x58).

Figure 7. LCD screenshot of a successful send transaction

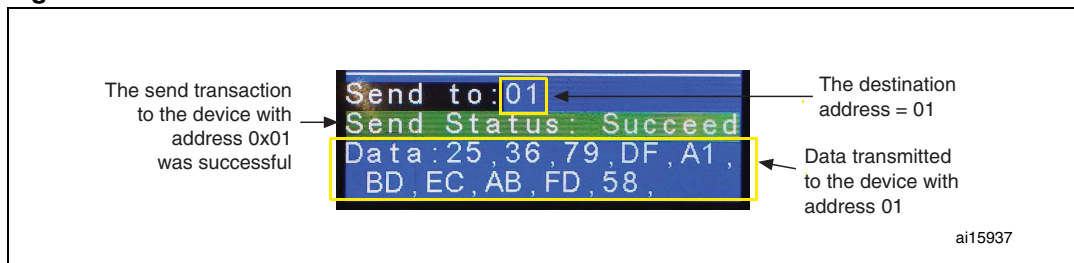

In *Figure 8* the frame (0xAA, 0x55,0x7E) was not sent to the intended destination (address 0x3). The frame is not acknowledged by the receiver.

Figure 8. LCD screen shot of a failed send transaction



4.5 Receive subscreen information

Figure 9 shows that the device has correctly received the frame from the sender with address 0x1. The data length (only data block) of the received frame is 0xA (10 bytes).

The received data are: 0xDF, 0x12, 0xD3, 0x56, 0x97, 0xA1, 0xEC, 0x7B, 0x4F, 0x22

Figure 9. LCD screenshot of a successful receive transaction

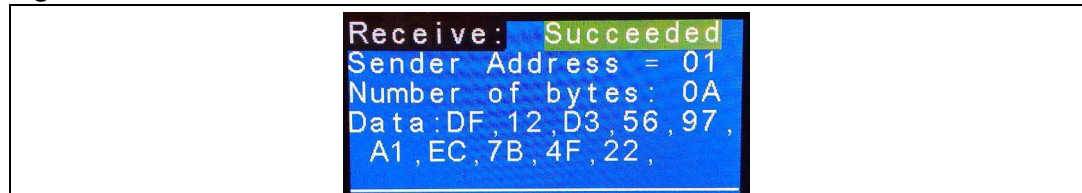

Figure 10 shows that the device detected a frame on the bus coming from the device with address 0x2, but it did not receive it because it is not the frame destination.

Figure 10. LCD screenshot of a detected frame

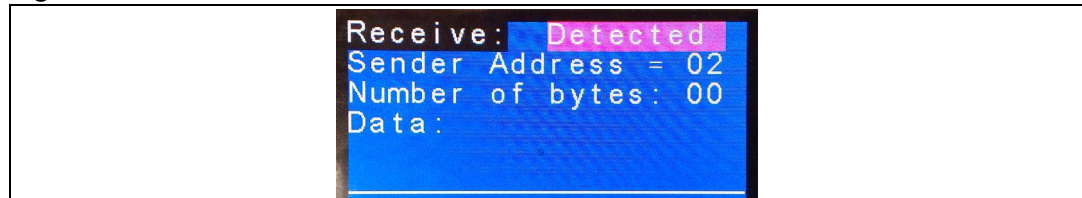
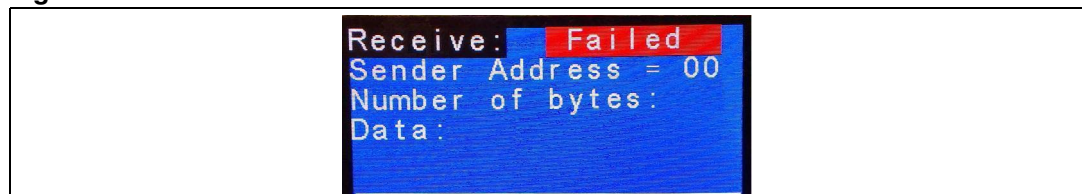

Figure 11 shows that an error has occurred while receiving the message.

Figure 11. LCD screenshot of a failed receive transaction



5 Conclusion

This user manual describes the STM32F10xxx CEC library, which contains the basic functions to communicate with the CEC protocol:

- CEC_Init: CEC initialization.
- CEC_SendStartBit: send CEC start bit.
- CEC_ReceiveStartBit: receive CEC start bit.
- CEC_SendAckBit: send CEC ACK bit (logical 0).
- CEC_ReceiveAckBit: receive CEC ACK bit.
- CEC_SendDataBit: send CEC data bit.
- CEC_ReceiveDataBit: receive CEC data bit.
- CEC_SendByte: send CEC Header/Data block
- CEC_ReceiveByte: receive CEC Header/Data block
- CEC_SendFrame: Send CEC frame with addressed messages.
- CEC_ReceiveFrame: receive CEC frame with addressed messages.

6 Revision history

Table 16. Document revision history

Date	Revision	Changes
06-Mar-2009	1	Initial release.
02-Nov-2009	2	u8 changed to uint8_t. u32 changed to uint32_t. vu32 changed to __IO uint32_t. void NVIC_Configuration(void) code removed from Example on page 8 .

Please Read Carefully:

Information in this document is provided solely in connection with ST products. STMicroelectronics NV and its subsidiaries ("ST") reserve the right to make changes, corrections, modifications or improvements, to this document, and the products and services described herein at any time, without notice.

All ST products are sold pursuant to ST's terms and conditions of sale.

Purchasers are solely responsible for the choice, selection and use of the ST products and services described herein, and ST assumes no liability whatsoever relating to the choice, selection or use of the ST products and services described herein.

No license, express or implied, by estoppel or otherwise, to any intellectual property rights is granted under this document. If any part of this document refers to any third party products or services it shall not be deemed a license grant by ST for the use of such third party products or services, or any intellectual property contained therein or considered as a warranty covering the use in any manner whatsoever of such third party products or services or any intellectual property contained therein.

UNLESS OTHERWISE SET FORTH IN ST'S TERMS AND CONDITIONS OF SALE ST DISCLAIMS ANY EXPRESS OR IMPLIED WARRANTY WITH RESPECT TO THE USE AND/OR SALE OF ST PRODUCTS INCLUDING WITHOUT LIMITATION IMPLIED WARRANTIES OF MERCHANTABILITY, FITNESS FOR A PARTICULAR PURPOSE (AND THEIR EQUIVALENTS UNDER THE LAWS OF ANY JURISDICTION), OR INFRINGEMENT OF ANY PATENT, COPYRIGHT OR OTHER INTELLECTUAL PROPERTY RIGHT.

UNLESS EXPRESSLY APPROVED IN WRITING BY AN AUTHORIZED ST REPRESENTATIVE, ST PRODUCTS ARE NOT RECOMMENDED, AUTHORIZED OR WARRANTED FOR USE IN MILITARY, AIR CRAFT, SPACE, LIFE SAVING, OR LIFE SUSTAINING APPLICATIONS, NOR IN PRODUCTS OR SYSTEMS WHERE FAILURE OR MALFUNCTION MAY RESULT IN PERSONAL INJURY, DEATH, OR SEVERE PROPERTY OR ENVIRONMENTAL DAMAGE. ST PRODUCTS WHICH ARE NOT SPECIFIED AS "AUTOMOTIVE GRADE" MAY ONLY BE USED IN AUTOMOTIVE APPLICATIONS AT USER'S OWN RISK.

Resale of ST products with provisions different from the statements and/or technical features set forth in this document shall immediately void any warranty granted by ST for the ST product or service described herein and shall not create or extend in any manner whatsoever, any liability of ST.

ST and the ST logo are trademarks or registered trademarks of ST in various countries.

Information in this document supersedes and replaces all information previously supplied.

The ST logo is a registered trademark of STMicroelectronics. All other names are the property of their respective owners.

© 2009 STMicroelectronics - All rights reserved

STMicroelectronics group of companies

Australia - Belgium - Brazil - Canada - China - Czech Republic - Finland - France - Germany - Hong Kong - India - Israel - Italy - Japan - Malaysia - Malta - Morocco - Philippines - Singapore - Spain - Sweden - Switzerland - United Kingdom - United States of America

www.st.com