

Getting started with the NFC card reader expansion board based on ST25R3916B for STM32 and STM8 Nucleos

Introduction

The X-NUCLEO-NFC08A1 NFC card reader expansion board is based on the ST25R3916B device.

The expansion board is configured to support ISO14443A/B, ISO15693, FeliCa™, and AP2P communication.

The ST25R3916B manages frame coding and decoding in reader mode for standard applications, such as NFC, proximity, and vicinity HF RFID standards. It supports ISO/IEC 14443 type A and B, ISO/IEC 15693 (single subcarrier only) and ISO/IEC 18092 communication protocols as well as the detection, reading and writing of NFC forum type 1, 2, 3, 4, and 5 tags.

The on-board low-power capacitive sensor performs ultra-low power wake-up without switching the reader field on and traditional inductive wake-up to select amplitude or phase measurement.

The automatic antenna tuning (AAT) technology enables operation close to metallic parts and/or in changing environments.

Figure 1. X-NUCLEO-NFC08A1 expansion board

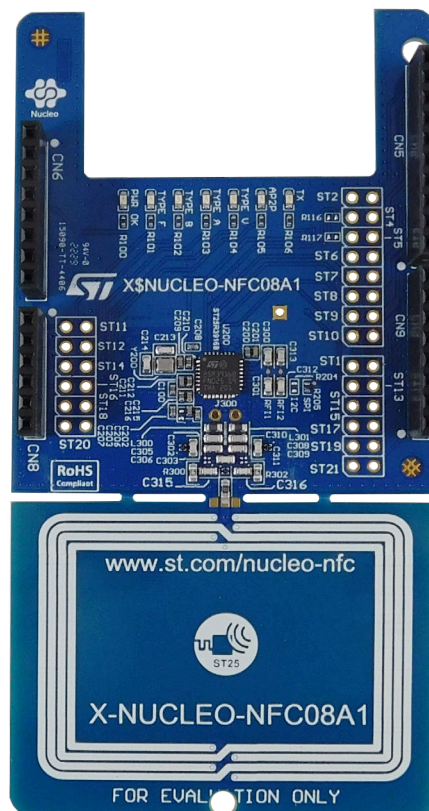

1 Getting started

1.1 Overview

The **X-NUCLEO-NFC08A1** expansion board features:

- On-board NFC card reader IC: [ST25R3916B](#)
- 47 mm x 34 mm, four turns, 13.56 MHz inductive antenna etched on PCB and associated tuning circuit
- Six general-purpose LEDs
- ISO 18092 passive and active initiator, ISO 18092 passive, and active target
- NFC-A and NFC-F card emulation
- ISO 14443A and ISO14443B
- ISO 15693
- FeliCa™
- Up to 1.7 W output power with differential antenna
- Possibility of driving two antennas in single-ended configuration
- Inductive wake-up
- Automatic antenna-tuning system
- Transparent and stream modes to implement MIFARE™ classic compliant or other custom protocols
- Equipped with Arduino UNO R3 connector
- Free comprehensive development firmware library compatible with [STM32Cube](#) and samples for [ST25R3916B](#)
- Scalable solution for multiple board cascade
- FCC certified
- RoHS and WEEE compliant

1.2 Board connection

Connect the **X-NUCLEO-NFC08A1** to an **STM32 Nucleo-64** development board via Arduino UNO R3 connectors. The PC USB port has to be capable of delivering at least 300 mA at 5 V supply.

A green LED indicates whether the 5 V supply is present, while the six status LEDs are controlled via MCU.

Provision for unpopulated jumpers enable alternative connections of all lines (except the SPI) to the STM32 MCU.

To demonstrate the wake-up feature, two capacitive electrodes are placed on the PCB and the automatic antenna tuning variable capacitors are also implemented.

The board is connected to a power supply. It should be used on a clean and non-flammable surface.

1.3 Hardware requirements

The **X-NUCLEO-NFC08A1** expansion board is designed to be used with any **STM32 Nucleo** board, although complete testing has been performed using the **NUCLEO-L476RG** hosting the **STM32L476RG** microcontroller.

The STM32 Nucleo firmware and the related documentation are available at <http://www.st.com/stm32nucleo>.

1.4 System requirements

To use **STM32 Nucleo** boards with the **X-NUCLEO-NFC08A1** expansion board the following software and hardware are required:

- an STM32 Nucleo-64 development board
- a Windows® PC to install the firmware package
- a USB type A to Mini-B USB cable to connect the STM32 Nucleo board to the PC
- the unit must be supplied by a safety extra low voltage with falling characteristics (<5 V, <15 W), according to EN60950-1. This power supply has to be classified as ES1 (Electrical Source1), PS1 according to EN62368-1

To install the board firmware package (order code: **X-CUBE-NFC6**) the PC must have:

- 128 MB of RAM
- 40 MB of free hard disk space

The X-CUBE-NFC6 firmware and the related documentation are available at www.st.com.

2 Board setup

To set up the board:

- Step 1.** Connect the [X-NUCLEO-NFC08A1](#) expansion board to the [STM32 Nucleo](#) board from the top through the Arduino UNO R3 connectors
- Step 2.** Power the [STM32 Nucleo](#) board using a Mini-B USB cable
- Step 3.** Program the firmware on the [STM32 Nucleo](#) board using the provided example
- Step 4.** Reset the MCU using the reset button available on the [STM32 Nucleo](#) board.
The evaluation kit is ready to be used.

3 Hardware

The X-NUCLEO-NFC08A1 expansion board allows the user to test the functionality of the ST25R3916B, which supports the reader/writer and the card emulation modes.

The ST25R3916B IC module and the STM32 Nucleo board are connected through CN5, CN6, CN8 and CN9 connectors (see the tables below).

Table 1. Interconnections between the X-NUCLEO-NFC08A1 expansion board and the NUCLEO-L476RG board (left side)

Signal	Connector	Pin number	NUCLEO-L476RG	X-NUCLEO-NFC08A1
NC	CN6 Power	1	-	-
IOREF		2	-	(NC)
RESET		3	-	-
3V3		4	-	3V3 (VDD_IO)
5V		5	-	5V (VDD)
GND		6	-	GND
GND		7	-	GND
VIN		8	-	-
A0	CN8 Power	1	PA0	IRQ_MCU
A1		2	PA1	MCU_LED1
A2		3	PA4	MCU_LED2
A3		4	PB0	MCU_LED3
A4		5	PC1	MCU_LED4
A5		6	PC0	MCU_LED5

Table 2. Interconnections between the X-NUCLEO-NFC08A1 expansion board and the NUCLEO-L476RG board (right side)

Signal	Connector	Pin number	NUCLEO-L476RG	X-NUCLEO-NFC08A1
D15	CN5 Digital	10	PB8	SCL_MCU
D14		9	PB9	SDA_MCU
AVDD		8	AVDD	NC
GND		7	GND	GND
D13		6	PA5	SCLK_MCU
D12		5	PA6	MISO_MCU
D11		4	PA7	MOSI_MCU
D10		3	PB6	/SS_MCU
D9		2	PC7	IRQ_MCU (alt.)
D8		1	PA9	/SS_MCU (alt.)
D7	CN9 Digital	8	PA8	MCU_LED6
D6		7	PB10	MCU_LED6 (alt.)
D5		6	PB4	/SS_MCU (alt.)
D4		5	PB5	MCU_LED2 (alt.)
D3		4	PB3	SCLK_MCU (alt.)
D2		3	PA10	MCU_LED3 (alt.)

Signal	Connector	Pin number	NUCLEO-L476RG	X-NUCLEO-NFC08A1
D1	CN9 Digital	2	PA2	NC
D0		1	PA3	NC

3.1 Host interface and GPIO connection

The X-NUCLEO-NFC08A1 expansion board contains the ST25R3916-AQFT chip and is powered by the STM32 Nucleo board.

The ST25R3916B is driven by the microcontroller via SPI interface.

The six LEDs indicate the detected RFID technology (for example, ISO14443 Type A for LED4).

3.2 X-NUCLEO-NFC08A1 expansion board component placement

Figure 2. X-NUCLEO-NFC08A1 component placement

1. General purpose LEDs
2. ST25R3916B
3. Matching circuit
4. 47x34 mm four-turn antenna

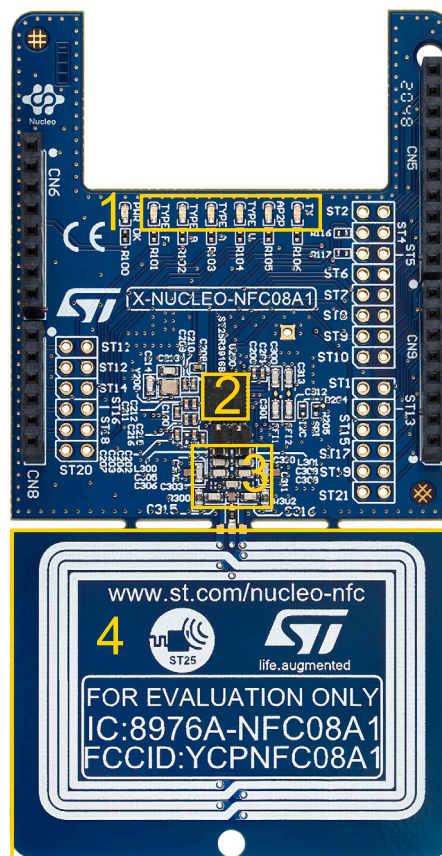

3.3 ST25R3916B device

The ST25R3916B is a high performance NFC universal device supporting NFC initiator, NFC target, NFC reader, and NFC card emulation modes.

The **ST25R3916B** includes an advanced analog front end (AFE) and a highly integrated data framing system for:

- ISO 18092 passive and active initiator, ISO18092 passive and active target
- NFC-A/B (ISO 14443A/B) reader including higher bit rates
- NFC-F (Felica™) reader
- NFC-V (ISO 15693) reader up to 53 kbps
- NFC-A and NFC-F card emulation

Special stream and transparent modes of the AFE and framing system can be used to implement other custom protocols such as MIFARE® classic in reader or card emulation mode.

4 Schematic diagrams

Figure 3. X-NUCLEO-NFC08A1 circuit schematic (1 of 3)

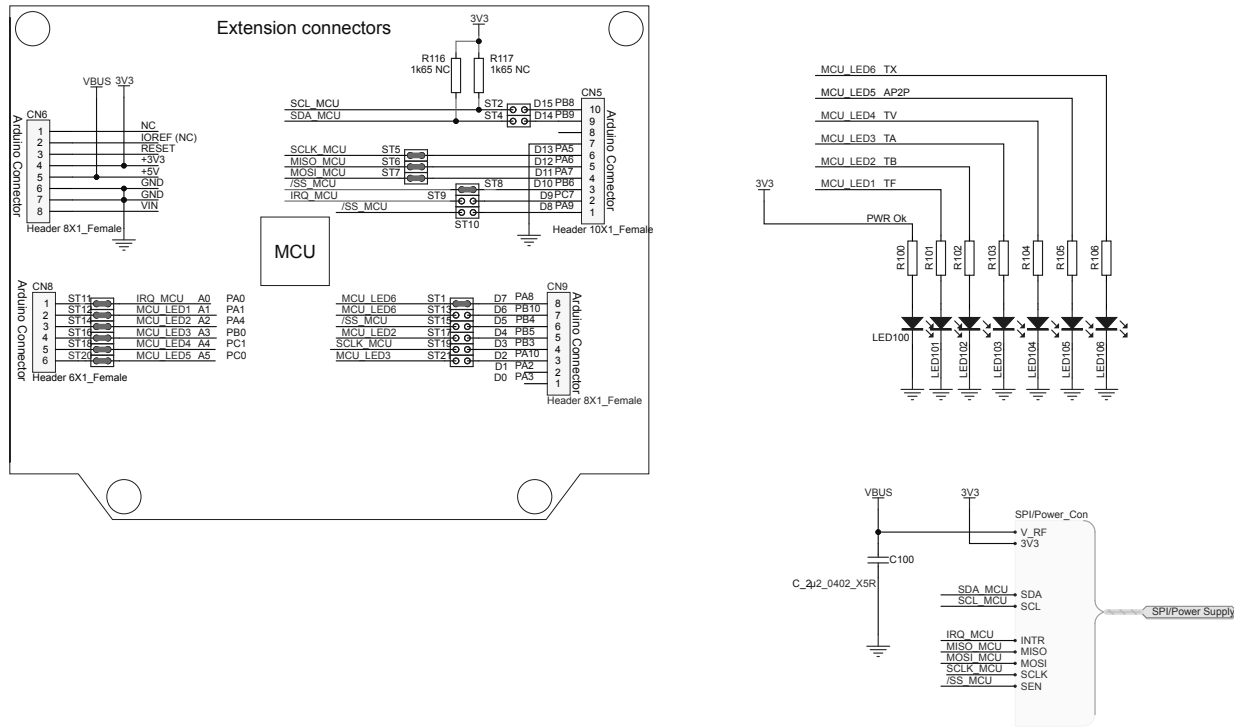

Figure 4. X-NUCLEO-NFC08A1 circuit schematic (2 of 3)

ST25R3916 NFC Initiator / HF Reader

Controller Interface

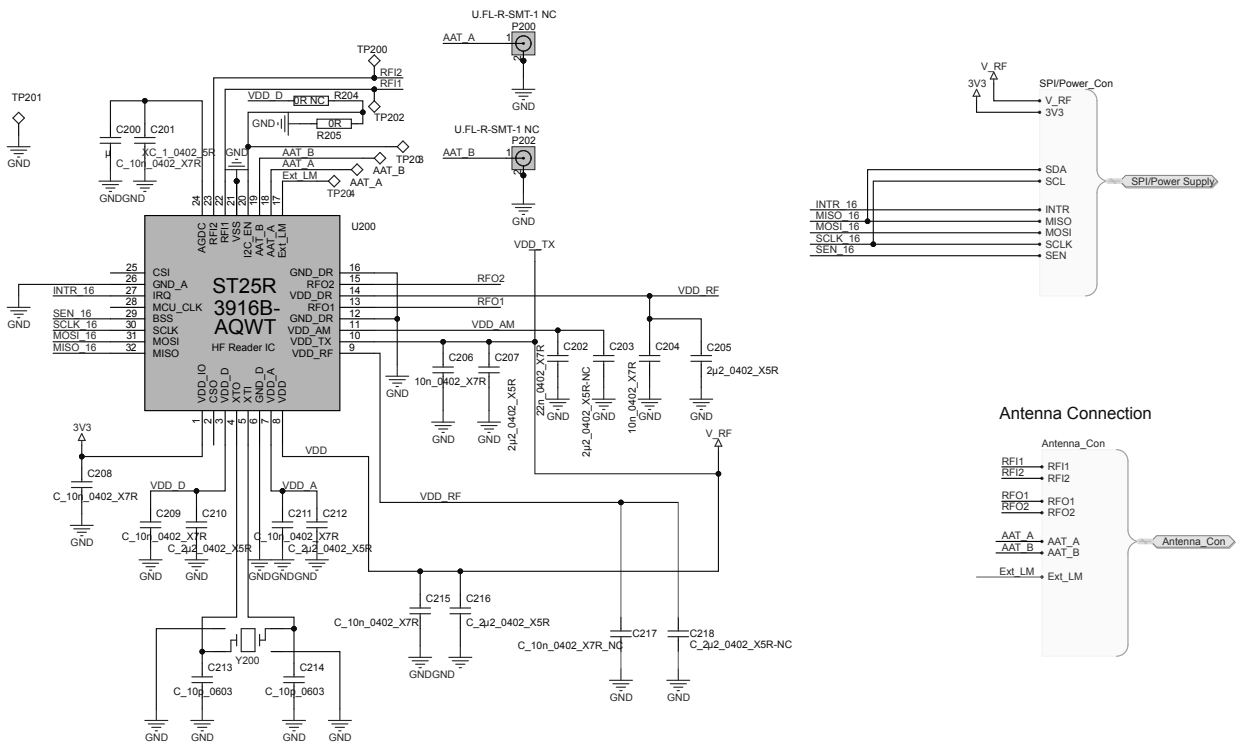
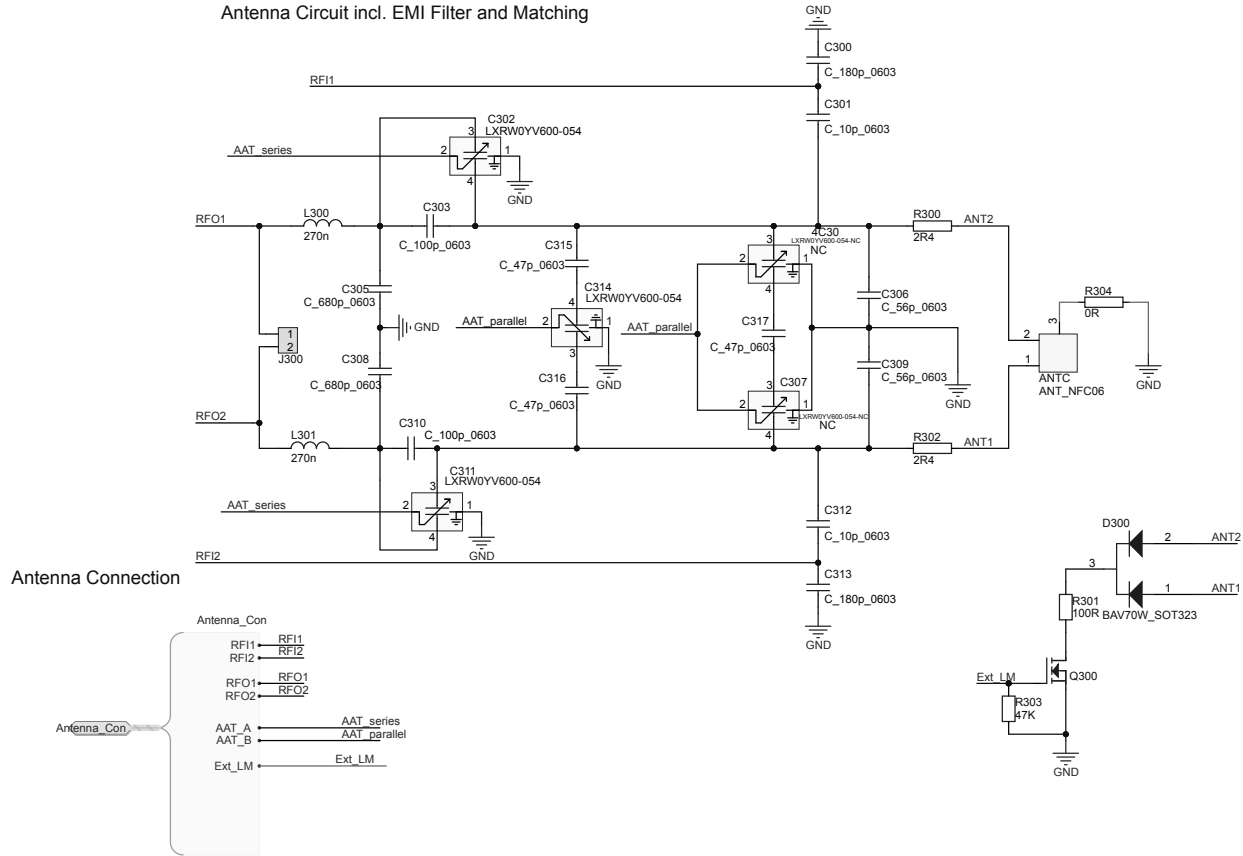

Figure 5. X-NUCLEO-NFC08A1 circuit schematic (3 of 3)



5 Bill of materials

Table 3. X-NUCLEO-NFC08A1 bill of materials

Item	Q.ty	Ref.	Part/Value	Description	Manufacturer	Order code
1	9	AAT_A, AAT_B, CSI, CSO, TP200, TP201, TP202, TP203, TP204		Test points	Any	Any
2	6	C100, C203, C207, C210, C212, C216	2 μ 2 X5R 0402 6.3 V \pm 20%	Capacitors	MURATA	GRM155R60J225ME15D
3	1	C200	1 μ X5R 0402 25 V \pm 10%	Capacitors	MURATA	GRM155R61C105KA12D
4	8	C201, C202, C204, C206, C208, C209, C211, C215	10 n_x7R 0402 25 V \pm 10%	Capacitors	AVX	04023C103KAT2A
5	1	C205	4 μ 7 X5R 0402 6.3 V \pm 10%	Capacitors	TDK	C1005X5R0J475K050BC
6	4	C213, C214, C301, C312	10 p COG 0603 50 V \pm 1%	Capacitors	MULTICOMP	MC0603N100F500CT
7	1	C217	10 n X7R NC 0402 25 V \pm 10%	Capacitors	AVX	04023C103KAT2A NOT FITTED
8	1	C218	2 μ 2 X5R NC 0402 6.3 V \pm 20%	Capacitors	MURATA	GRM155R60J225ME15D NOT FITTED
9	2	C300, C313	180 p COG 0603 50 V \pm 1%	Capacitors	MURATA	GRM1885C1H181GA01D
10	3	C302, C311, C314	CSP_06_06	Capacitors	muRata	LXRW0YV600-054
11	2	C304, C307	CSP_06_07	Capacitors	muRata	LXRW0YV600-054
12	2	C303, C310	100 p COG 0603 50 V \pm 1%	Capacitors	MURATA	GRM1885C1H101FA01D
13	2	C305, C308	680 p COG 0603 \pm 2%	Capacitors	MURATA	GRM1885C1H681GA01D
14	2	C306, C309	56 p COG 0603	Capacitors	MURATA	GRM1885C1H560FA01D
15	2	C315, C316	82 p COG 0603	Capacitors	MURATA	GRM1885C1H820FA01D
16	1	C317	47 p COG NC 0603	Capacitors	MURATA	GRM1885C1H470FA01D
17	1	CN5	Single row, female	10-pin header	Samtec	SSQ-110-03-L-S
18	2	CN6, CN9	Single row, female	8-pin header	Samtec	SSQ-108-03-L-S
19	1	CN8	Single row, female	6-pin header	Samtec	SSQ-106-03-L-S
20	1	D300	SOT323	Dual surface mount switching diode	Diodes Inc	BAV70W-7-F
21	1	J300	Male single row horizontal 2 pin_NC	Jumper	Any	Any
22	2	L300, L301	LQW18CNR27J00 D 0603 550 mA	Multi-layer ferrite	TDK	MLJ1608WR27JT000
23	1	LED100	0603	Green LED	Lite-On	LTST-C190KGKT

Item	Q.ty	Ref.	Part/Value	Description	Manufacturer	Order code
24	6	LED101, LED102, LED103, LED104, LED105, LED106	0603	Blue LED	Lite-On	LTST-C190TBKT
25	4	P200, P201, P202, P203	U.FL-R-SMT-1 (not fitted)	Co-axial connectors	HIROSE(HRS)	U.FL-R-SMT-1(10)
26	1	Q300	NX3008NBK SOT23	NCh MOSFET	NEXPERIA	NX3008NBK
27	1	R100	680 R, 0402 100 V 1/16 A ±5%	Resistors	Yageo	RC0402JR-07680RL
28	6	R101, R102, R103, R104, R105, R106	1k, 0402	Resistors	Panasonic	ERJ2GEJ102X
29	2	R116, R117	1 k65, 0402 (not fitted)	Resistors	MULTICOMP	MC00625W040211K65
30	2	R200, R202	50 R, 0402 50 V	Resistors	MULTICOMP	MCMR04X49R9FTL
31	1	R204	0 R, 0402 (not fitted)	Resistors	MULTICOMP	MC00625W040210R
32	1	R205	0 R, 0402	Resistors	MULTICOMP	MC00625W040210R
33	2	R300, R302	2 R4, 0603	Resistors	Any	Any
34	1	R301	100 R 0402	Resistors	ANY	Any
35	1	R303	47 K 0402	Resistors	ANY	Any
36	1	R304	0 R, 0603	Resistors	Any	Any
37	11	ST1, ST5, ST6, ST7, ST8, ST11, ST12, ST14, ST16, ST18, ST20	CONN HE14 2PTS male vertical (not fitted)	Connectors	Any	Any
38	9	ST2, ST4, ST9, ST10, ST13, ST15, ST17, ST19, ST21	CONN HE14 2PTS male vertical (not fitted)	Connectors	Any	Any
39	1	U200	ST25R3916B- AQWT, VFQFPN 5X5X1 32L WETTABLE FLANKS	High performance NFC universal device and EMVCo reader	ST	ST25R3916B-AQWT
40	1	Y200	NDK NX2016SA 27.12 MHz	Crystal	MURATA	NX2016SA STD-CZS-5

6 Board versions

Table 4. X-NUCLEO-GNSS2A1 versions

PCB version	Schematic diagrams	Bill of materials
X\$NUCLEO-NFC08A1	X\$NUCLEO-NFC08A1 schematic diagrams	X\$NUCLEO-NFC08A1 bill of materials

1. This code identifies the X-NUCLEO-NFC08A1 expansion board first version. It is printed on the board PCB.

7 Federal Communications Commission (FCC) and Innovation, Science and Economic Development Canada (IC) compliance

7.1 FCC Compliance Statement

7.1.1 Part 15.19

This device complies with Part 15 of the FCC Rules. Operation is subject to the following two conditions: (1) this device may not cause harmful interference, and (2) this device must accept any interference received, including interference that may cause undesired operation.

7.1.2 Part 15.21

Any changes or modifications to this equipment not expressly approved by STMicroelectronics may cause harmful interference and void the user's authority to operate this equipment.

7.1.3 Part 15.105

This equipment has been tested and found to comply with the limits for a Class B digital device, pursuant to part 15 of the FCC Rules. These limits are designed to provide reasonable protection against harmful interference in a residential installation. This equipment generates, uses and can radiate radio frequency energy and, if not installed and used in accordance with the instructions, may cause harmful interference to radio communications. However, there is no guarantee that interference will not occur in a particular installation. If this equipment does cause harmful interference to radio or television reception, which can be determined by turning the equipment off and on, the user is encouraged to try to correct the interference by one or more of the following measures:

- Reorient or relocate the receiving antenna.
- Increase the separation between the equipment and receiver.
- Connect the equipment into an outlet on a circuit different from that to which the receiver is connected.
- Consult the dealer or an experienced radio/TV technician for help.

7.1.4 FCC ID

FCC ID: YCPNFC08A1

7.2 Formal notices required by Innovation, Science and Economic Development Canada ("IC")

7.2.1 Compliance statement

This device complies with Innovation, Science and Economic Development Canada's license-exempt RSS standard(s). Operation is subject to the following two conditions: (1) this device may not cause interference, and (2) this device must accept any interference, including interference that may cause undesired operation.

7.2.2 Compliance declaration

This device contains license-exempt transmitter(s)/receiver(s) that comply with Innovation, Science and Economic Development Canada's license-exempt RSS(s). Operation is subject to the following two conditions:

- (1) This device may not cause interference.
- (2) This device must accept any interference, including interference that may cause undesired operation of the device.

L'émetteur/récepteur exempt de licence contenu dans le présent appareil est conforme aux CNR d'Innovation, Sciences et Développement économique Canada applicables aux appareils radio exempts de licence. L'exploitation est autorisée aux deux conditions suivantes:

- 1) L'appareil ne doit pas produire de brouillage;
- 2) L'appareil doit accepter tout brouillage radioélectrique subi, même si le brouillage est susceptible d'en compromettre le fonctionnement.

7.2.3**IC ID**

IC ID: 8967A-NFC08A1

Note:

The grantee is not responsible for any changes or modifications not expressly approved by the party responsible for compliance. Such modifications could void the user's authority to operate the equipment.

8 Europe and UK regulatory compliance information

Notice for the European Union

The X-NUCLEO-NFC08A1 is in conformity with the essential requirements of the Directive 2014/53/EU (RED) and of the Directive 2015/863/EU (RoHS). Applied harmonized standards are listed in the EU Declaration of Conformity.

Notice for United Kingdom

The X-NUCLEO-NFC08A1 is in compliance with the UK Radio Equipment Regulations 2017 (UK SI 2017 No. 1206 and amendments) and with the Restriction of the Use of Certain Hazardous Substances in Electrical and Electronic Equipment Regulations 2012 (UK SI 2012 No. 3032 and amendments). Applied standards are listed in the UK Declaration of Conformity.

Revision history

Table 5. Document revision history

Date	Revision	Changes
14-Sep-2022	1	Initial release.

Contents

1	Getting started	2
1.1	Overview	2
1.2	Board connection	2
1.3	Hardware requirements	2
1.4	System requirements	2
2	Board setup	4
3	Hardware	5
3.1	Host interface and GPIO connection	6
3.2	X-NUCLEO-NFC08A1 expansion board component placement	6
3.3	ST25R3916B device	6
4	Schematic diagrams	8
5	Bill of materials	11
6	Board versions	13
7	Federal Communications Commission (FCC) and Innovation, Science and Economic Development Canada (IC) compliance	14
7.1	FCC Compliance Statement	14
7.1.1	Part 15.19	14
7.1.2	Part 15.21	14
7.1.3	Part 15.105	14
7.1.4	FCC ID	14
7.2	Formal notices required by Innovation, Science and Economic Development Canada (“IC”)	14
7.2.1	Compliance statement	14
7.2.2	Compliance declaration	14
7.2.3	IC ID	15
8	Europe and UK regulatory compliance information	16
	Revision history	17
	List of tables	19
	List of figures	20

List of tables

Table 1.	Interconnections between the X-NUCLEO-NFC08A1 expansion board and the NUCLEO-L476RG board (left side)	5
Table 2.	Interconnections between the X-NUCLEO-NFC08A1 expansion board and the NUCLEO-L476RG board (right side)	5
Table 3.	X-NUCLEO-NFC08A1 bill of materials	11
Table 4.	X-NUCLEO-GNSS2A1 versions	13
Table 5.	Document revision history	17

List of figures

Figure 1.	X-NUCLEO-NFC08A1 expansion board	1
Figure 2.	X-NUCLEO-NFC08A1 component placement	6
Figure 3.	X-NUCLEO-NFC08A1 circuit schematic (1 of 3)	8
Figure 4.	X-NUCLEO-NFC08A1 circuit schematic (2 of 3)	9
Figure 5.	X-NUCLEO-NFC08A1 circuit schematic (3 of 3)	10

IMPORTANT NOTICE – READ CAREFULLY

STMicroelectronics NV and its subsidiaries (“ST”) reserve the right to make changes, corrections, enhancements, modifications, and improvements to ST products and/or to this document at any time without notice. Purchasers should obtain the latest relevant information on ST products before placing orders. ST products are sold pursuant to ST’s terms and conditions of sale in place at the time of order acknowledgment.

Purchasers are solely responsible for the choice, selection, and use of ST products and ST assumes no liability for application assistance or the design of purchasers’ products.

No license, express or implied, to any intellectual property right is granted by ST herein.

Resale of ST products with provisions different from the information set forth herein shall void any warranty granted by ST for such product.

ST and the ST logo are trademarks of ST. For additional information about ST trademarks, refer to www.st.com/trademarks. All other product or service names are the property of their respective owners.

Information in this document supersedes and replaces information previously supplied in any prior versions of this document.

© 2022 STMicroelectronics – All rights reserved