

## STM32U0 Series UL/CSA/IEC 60730-1/60335-1 self-test library user guide

### Introduction

This document applies to the **X-CUBE-CLASSB** self-test library set for the STM32U0 series microcontrollers that include an Arm® Cortex®-M0+ core. Order code X-CUBE-CLASSB-U0.

Safety has an essential role in electronic applications. The level of safety requirements for components is steadily increasing and, manufacturers of electronic devices include many new technical solutions in their designs. Techniques for improving safety are continuously evolving, and are regularly incorporated into updated versions of the safety standards.

The current safety recommendations and requirements are specified in worldwide standards issued by various authorities. These include: the international electro-technical commission (IEC), Underwriters laboratories (UL), and the Canadian standards association (CSA) authorities.

Compliance, verification, and certification are the focus of the certification institutes. These include: the German TUV and VDE (mostly operating in Europe), and the UL and the CSA (targeting mainly the USA and Canadian markets).

Standards related to safety requirements have a very wide scope. These safety standards cover many areas such as: classification, methodology, materials, mechanics, labeling, hardware, and software testing. Here, the target is just compliance with the software requirements when testing programmable electronic components, which form a specific part of the safety standards. These requirements are exceptionally subject of any change when a new upgrade of the standard is released. Also, there is significant similarity across commonly oriented safety standards that concern the testing of generic parts of microcontrollers, such as the *CPU* or memories.

The library presented in this document is based on a partial subset of testing modules developed and applied by ST to satisfy the stringent IEC 61508 industrial safety standard requirements. These modules are adapted to fulfill the IEC 60730 standard targeting household safety. That is why this new library adopts a different delivery format to that was used for previous releases. This format is derived from the industrial safety library, which is currently delivered as a black box pre-compiled object with no sources but with a clear outer interface definition. The advantage of this immutable solution is that it is compilation tool-chain agnostic. It is also independent of any other firmware such as *HAL*, *LL*, or *CMSIS* layer. This solution prevents unexpected compilation results when source code files previously verified on older versions of the library are re-compiled later by any newer compiler version or combined with the latest firmware drivers. This is generally a common practice.

**Table 1. Applicable product**

| Part number   | Order code       |
|---------------|------------------|
| X-CUBE-CLASSB | X-CUBE-CLASSB-U0 |



## 1 General information

### 1.1 Purpose and scope

This document applies to the specific subset X-CUBE-CLASSB-U0 which extends the available set of X-CUBE-CLASSB self test libraries by support of STM32U0 series series embedding the Arm® Cortex®-M0+ core. This X-CUBE-CLASSB-U0 expansion package provides application independent software to comply with the UL/CSA/IEC 60730-1 safety standard. The UL/CSA/IEC 60730-1 safety standard targets the safety of automatic electrical controls used in association with household equipment and similar electronic applications.

The main purpose of this software library is to facilitate and accelerate:

- user software development
- certification processes for applications which are subject to the associated requirements and certifications



*Note:* Arm is a registered trademark of Arm limited (or its subsidiaries) in the US and/or elsewhere.

The version of the application-independent software test library, self-test library, available in the X-CUBE-CLASSB-U0 expansion package (and associated to this manual), `STL_Lib.a` file, is V4.0.0.

### 1.2 Reference documents

- [1] UM3261, STM32U0 Series safety manual dedicated for applications targeting industrial safety
- [2] AN4435, Guidelines for obtaining UL/CSA/IEC 60730-1/60335-1 Class B certification in any STM32 application dedicated to older versions of this library
- [3] ES0647, X-CUBE-CLASSB self test library software errata

## 2 STM32Cube overview

### 2.1 What is STM32Cube?

STM32Cube is an STMicroelectronics original initiative to improve designer productivity significantly by reducing development effort, time, and cost. STM32Cube covers the whole STM32 portfolio.

STM32Cube includes:

- A set of user-friendly software development tools to cover project development from conception to realization, among which are:
  - [STM32CubeMX](#), a graphical software configuration tool that allows the automatic generation of C initialization code using graphical wizards
  - [STM32CubeIDE](#), an all-in-one development tool with peripheral configuration, code generation, code compilation, and debug features
  - [STM32CubeCLT](#), an all-in-one command-line development toolset with code compilation, board programming, and debug features
  - STM32CubeProgrammer ([STM32CubeProg](#)), a programming tool available in graphical and command-line versions
  - STM32CubeMonitor ([STM32CubeMonitor](#), [STM32CubeMonPwr](#), [STM32CubeMonRF](#), [STM32CubeMonUCPD](#)), powerful monitoring tools to fine-tune the behavior and performance of STM32 applications in real time
- [STM32Cube MCU and MPU Packages](#), comprehensive embedded-software platforms specific to each microcontroller and microprocessor series (such as STM32CubeU0 for the STM32U0 series), which include:
  - STM32Cube hardware abstraction layer (HAL), ensuring maximized portability across the STM32 portfolio
  - STM32Cube low-layer APIs, ensuring the best performance and footprints with a high degree of user control over hardware
  - A consistent set of middleware components such as ThreadX, FileX, LevelX, NetX Duo, USBX, USB PD, touch library, network library, mbed-crypto, TFM, and OpenBLRTOS, USB, and graphics
  - All embedded software utilities with full sets of peripheral and applicative examples
- [STM32Cube Expansion Packages](#), which contain embedded software components that complement the functionalities of the STM32Cube MCU and MPU Packages with:
  - Middleware extensions and applicative layers
  - Examples running on some specific STMicroelectronics development boards

### 2.2 How does this software complement STM32Cube?

The software expansion package extends [STM32Cube](#) by a middleware component to manage specific software-based diagnostics.

The package provides a generic starting point to help a user to build and finalize application specific safety solutions. It consists of:

- *STL*: the self-test library. This provides a binary and some source code to manage the execution of generic safety tests for the microcontroller. The *STL* is a standalone unit, which runs independently from any STM32 software. It collects the self-tests for generic components of the microcontroller.
- User application: This is an *STL* integration example based on a set of [STM32Cube](#) drivers extending the *STL* by an application specific test. This part is delivered as full source code to be adapted or extended by calling of additional application specific modules defined by end user. The example can be used for the library testing including artificial failing support of all the provided modules.

### 3 STL overview

The *STL* is an application-independent software test library released by STMicroelectronics. The aim is to provide the implementation of a relevant subset of safety mechanisms required by the "Class B" related safety standards applicable to STM32U0 series microcontrollers. The *STL* is an *HAL / LL* independent library, dedicated to these microcontrollers. The *STL* is a compilation tool chain-agnostic, so any standard C-compiler can compile it.

The *STL* is an autonomous software. It executes, on application-demand, selected tests to detect hardware issues, and reports the outcomes to the application.

The *STL* is delivered partly in object code (for the library itself) and partly in source code for the user interface definitions and the user parameter settings.

#### 3.1 Architecture overview

The *STL* implements tests required by UL/CSA/IEC 60730-1 for the Arm® Cortex®-M0+ *CPU* core, and the volatile and nonvolatile memories embedded in the product.

As shown in the figure below, a system architecture with an end-user application integrating the *STL* is composed of:

- User application (indicated in light blue)
- User parameters (indicated in light blue)
- *STL* scheduler (indicated in yellow): directly accessible by the user application via user *APIs* (not going through *HAL / LL*)
- *STL* internal test modules: called by the *STL* scheduler (not visible to the user application).

The *STL* status information returned to the user application at *API* level (summarized in [Table 2](#)) is:

- Function return value collects result of internal defensive programming checks.
- Test module result value stores the test result information. This partially corresponds to internal status of the module (see [Section 7.3: State machines](#)).

Figure 1. *STL* architecture

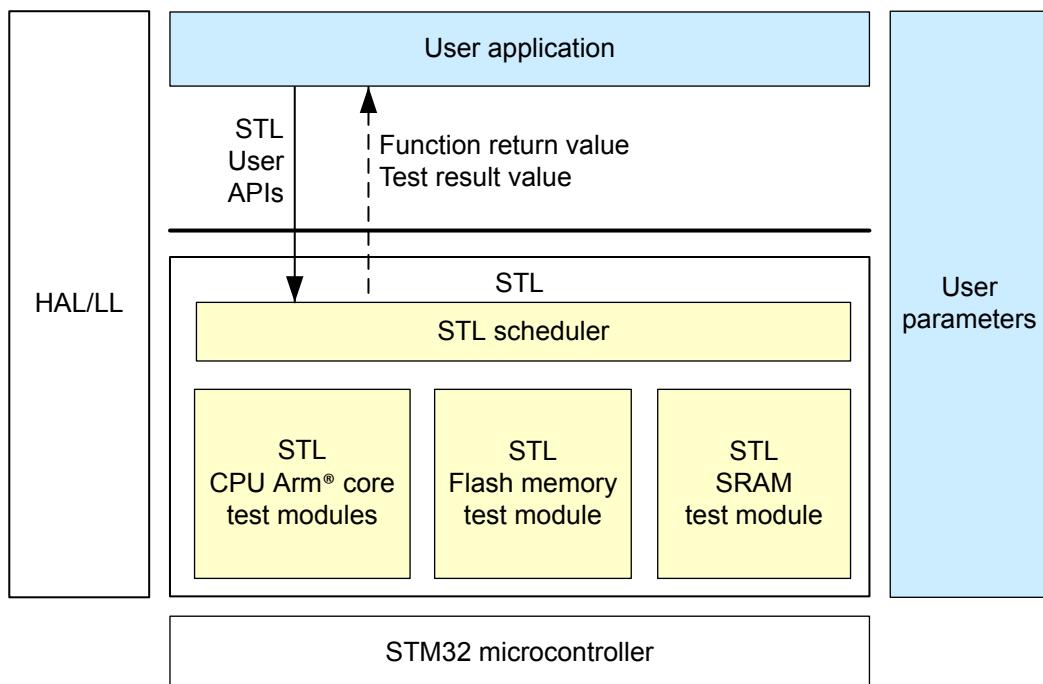

Legend:  
 STL   
 User

DT67412V1

The *STL* also allows the developer to use the artificial-failing feature. The developer can check the application behavior by forcing the *STL* to return a requested test-result value. This feature is available through the specific user API.

### 3.2 Supported products

The *STL* runs on the STM32U0 series microcontrollers featuring the same design and integration of the Cortex®-M0+ core and the embedded memories.

## 4 STL description

This section describes basic information on the functionality and performance of the *STL*. The section also summarizes restrictions and mandatory actions to be followed by the end user.

### 4.1 STL functional description

Some test modules can temporarily mask interrupts. For more details, refer to [Section 4.2.5: STL interrupt masking time](#) and to [Section 4.3.4: Interrupt management](#).

#### 4.1.1 Scheduler principle

The scheduler is the *API* module needed by the user application to execute the *STL*.

The main scheduler:

- Must be initialized before being used
- Manages:
  - The initialization and deinitialization of the applied test modules
  - The configuration of the applied test modules
  - The reset of the applied test modules.
- Controls the execution of an applied test sequence (*API* calls)
- Manages "artificial failing" used for user debug and integration tests.
- Ensures the integrity of critical internal data structures via their specific checksums.

The scheduler controls the execution of the following tests:

- *CPU* tests: no specific initialization or configuration procedures of the *CPU* test module are required before any *CPU* test execution (see [Section 7.2: User APIs](#) and [Figure 11](#)).
- Flash memory tests operate on the content of the dedicated user configuration structures defining subsets of the memory to be tested (see [Section 7.1: User structures](#)). These structures must be filled by the end user and the content maintained during both configuration and execution of the flash memory test. The test module initialization and configuration procedures are mandatory before any flash memory test execution, see [Section 7.2: User APIs](#) and [Figure 12](#).
- RAM memory tests operate on the content of the dedicated user configuration structures defining subsets of the memory to be tested (see [Section 7.1: User structures](#)). These structures must be filled by the end user and the content maintained during both configuration and execution of the RAM test. The test module initialization and configuration procedures are mandatory before any RAM test execution, see [Section 7.2: User APIs](#) and [Figure 13](#).

The *STL*, via the scheduler *API*, is called by the user in polling mode. The *STL* can be called under an interrupt context, but reentrance is forbidden. In such cases, the *STL* behavior cannot be guaranteed.

The user application has to consider all the returned information from the *STL*, provided via a specific predefined data structure collecting status information. See details in the following table.

Table 2. STL return information

| STL information                         | Value              | Description   |
|---|--------------------|---|
| Function return value <sup>(1)</sup>    | STL_OK             | Scheduler function successfully executed  |
|   | STL_KO             | Scheduler defensive programming error (in this case the test result is not relevant)                            |
| Test module result value <sup>(2)</sup> | STL_PASSED         | Test passed   |
|   | STL_PARTIAL_PASSED | Used only for memory testing when the test passed, but the end of memory configuration has not yet been reached |
|   | STL_FAILED         | Hardware error detection by test module   |
|   | STL_NOT_TESTED     | Test not executed   |
|   | STL_ERROR          | Test module defensive programming error   |

1. Refer to *STL\_Status\_t* definition in Section 7.1: User structures.

2. See *STL\_TmStatus\_t* in Section 7.1: User structures.

The user application repeatedly applies the call control scheme illustrated in the following figure to program a sequence of API function calls and so handle the order of the test modules execution.

Figure 2. Single test control call architecture

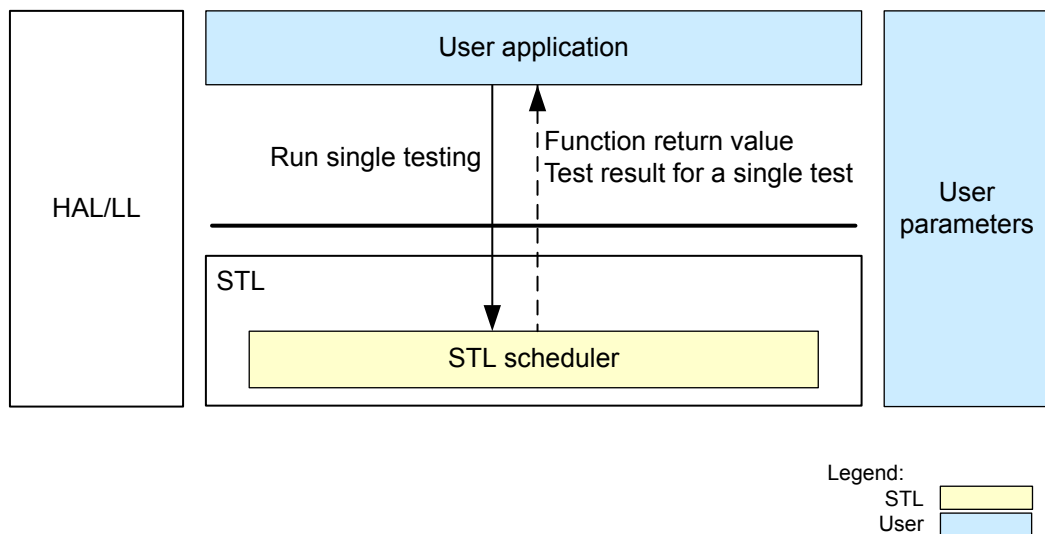

### Scheduler and interrupts

The scheduler can be interrupted at any time.

#### 4.1.2 CPU Arm® core tests

The STL includes the CPU test modules listed below, together with a generic description (for information only) of the test capability:

- TM1L: implements a light pattern test of general-purpose registers
- TM7: implements the pattern and functional tests of both stack pointers: *MSP*, and *PSP*
- TMCB: implements test of the *APSR* status register.

**Caution:** *The STL CPU tests are partitioned in separated test modules. This is not intended to allow partial execution of the overall available CPU TMs. It is intended as a support feature to allow better CPU test scheduling in the end-user applications, for example timing constraints. By default, all available TMs are assumed to be executed.*

## CPU Arm® core tests and interrupts

The CPU test modules are interruptible at any time. The **TM7** one only applies masking interrupt during the smallest data granularity time. Refer to [Section 4.3.4: Interrupt management](#) for detailed information on *CPU TM7* interrupt management.

### 4.1.3 Flash memory tests

#### Principles

The flash test concerns the embedded flash memory of STM32U0 series.

The following structures must be respected to provide correct configuration of the flash memory test.

- Block: a continuous area of 4 bytes (`FLASH_BLOCK_SIZE`), hard coded by *STL*.
- Section: a continuous area of 1024 bytes (`FLASH_SECTION_SIZE`), hard coded by the *STL*. This has no link with the memory physical sector. The memory is partitioned in sections. The first section starts at the first address of the memory, and the following sections are contiguous with each other.  
The user must ensure proper calculation and placement of the *CRC* checksum for each section that is to be checked during the memory integrity test.
- Binary (named 'user program' in [Figure 4](#)): a continuous area of code provided by the compiler. It starts at the beginning of a section. It usually ends with an incomplete section when the binary area size is not a multiple of the section size. In all cases, the binary must be 32-bit aligned (see [ST CRC tool information](#) below).
- Subset: a continuous area of contiguous sections defined by the user. The user application can define one subset or several subsets. A subset has to be defined within a binary area. Its start address has to be aligned with the beginning of a section. It can only include sections with the corresponding precalculated *CRC* values. When the last section of a subset is the last part of the binary, the section may be incomplete. The user application has to align the end of the subset with the end address of the binary area. If a set of complete sections is tested exclusively, the subset end address has to be aligned with the end of the last-tested section.

The subset is calculated as follows:

$$\text{Subset size} = K * \text{FLASH\_SECTION\_SIZE} + L * \text{FLASH\_BLOCK\_SIZE}$$

where:

- K is an integer greater than 0.
- $0 \leq L < (\text{FLASH\_SECTION\_SIZE} / \text{FLASH\_BLOCK\_SIZE})$  when  $L > 0$  the last section of a binary is incomplete.

The user application defines single or multiple subsets as well as their associated test sequences.

The *STL* implements a test of the flash memory with the following principles (based on actual content of the user configuration structures):

- Tests are performed on sections of one or more subsets defined by the user application.
- Tests are performed either in a row (one shot) or partially in a single atomic step for a number of sections defined by the user application.
- Test results are based on a *CRC* comparison between the computed *CRC* value (calculated during test execution) and an expected *CRC* value (calculated before software binary flashing).

The mandatory steps (for the user application) to perform flash memory tests are:

- Test initialization
- Configuration of one or more subsets
- Execution of the test.

Once all subsets are tested, the user needs to reset the flash memory test module to perform the test again.

In the case of an `STL_ERROR` / `STL_FAILED` test result, the test module is stuck at the failed memory subset. In this case, deinitialize, initialize and reconfigure the flash memory test prior to running it again.

#### Expected CRC precalculation

The flash memory test is based either on the embedded hardware *CRC* calculation unit or software *CRC* computation algorithm, which is configurable by a flag. The default configuration is with the *CRC* hardware unit. To use the software *CRC*, the flag `STL_SW_CRC` must be enabled as defined in step 3 in [Section 5.5.2: Steps to build an application from scratch](#). The *CRC* is a 32-bit *CRC* compliant with IEEE 802.3.



Part of the flash memory is reserved for the *CRC* dedicated area, the size of which depends on the flash memory size. This area has a field format where each flash memory section has sufficient reserved space to store a 32-bit *CRC* pattern. The user must ensure that valid *CRC* patterns are calculated and stored in the fields for all the sections to be tested. This is shown in [Figure 3](#).

One expected *CRC* value is precalculated for each contiguous section of a binary, from binary start to binary end. This means that the number of testable sections depends on the binary size. Commonly, the binary area is not aligned with the section size. In that case, the *CRC* check value of the last incomplete section is precalculated and tested exclusively over the section part that overlays the binary area.

Preconditions:

- The user program areas have to start at the beginning of a section
- The boundaries of the user program areas must be 32-bit aligned.
- Depending on total flash memory size and on user program size, last program data and first *CRC* data may be both stored in the same flash section (without any overlap). In that case, the *CRC* must be computed on the user program data only, see example 3 in [Figure 4](#).

### ST CRC tool information

ST provides a *CRC* precalculation tool. This tool is available as a single feature inside the STM32CubeProgrammer (see [Section 6.2.2: CRC tool set-up](#)), which automatically fills the binary with padding bits (0x00 pattern) for a 32-bit alignment.

**Figure 3. Flash memory test: CRC principle**

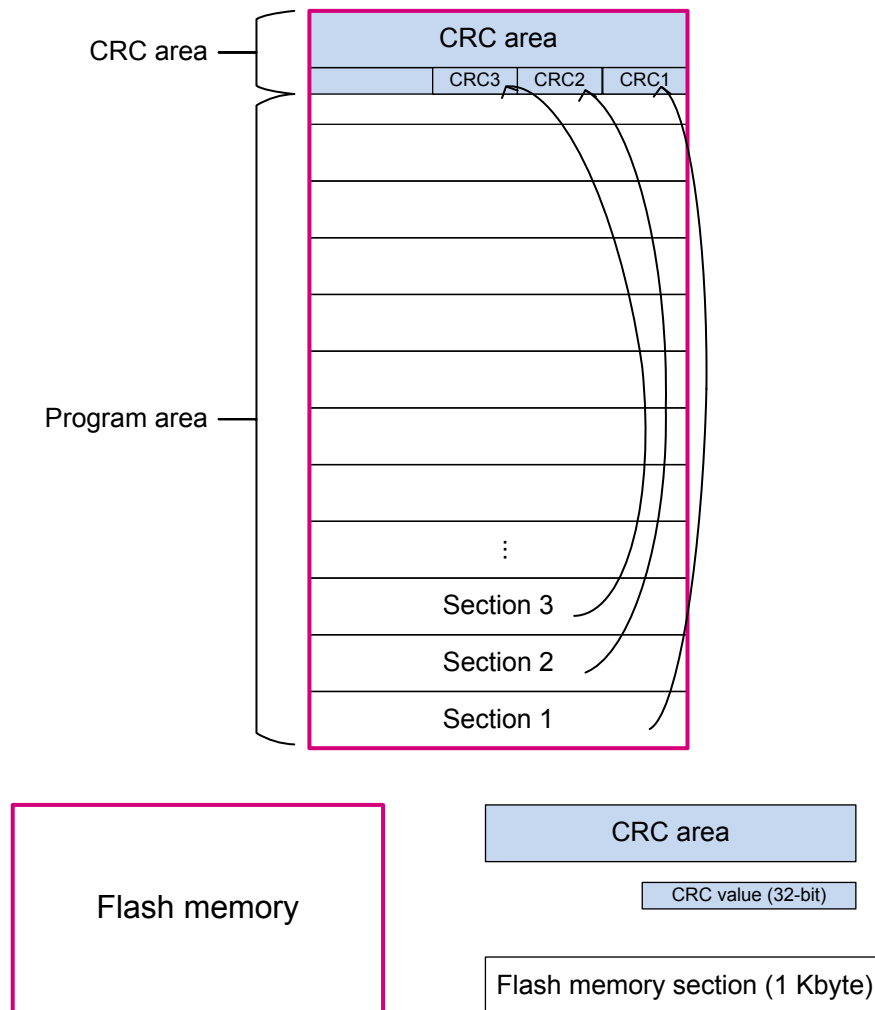
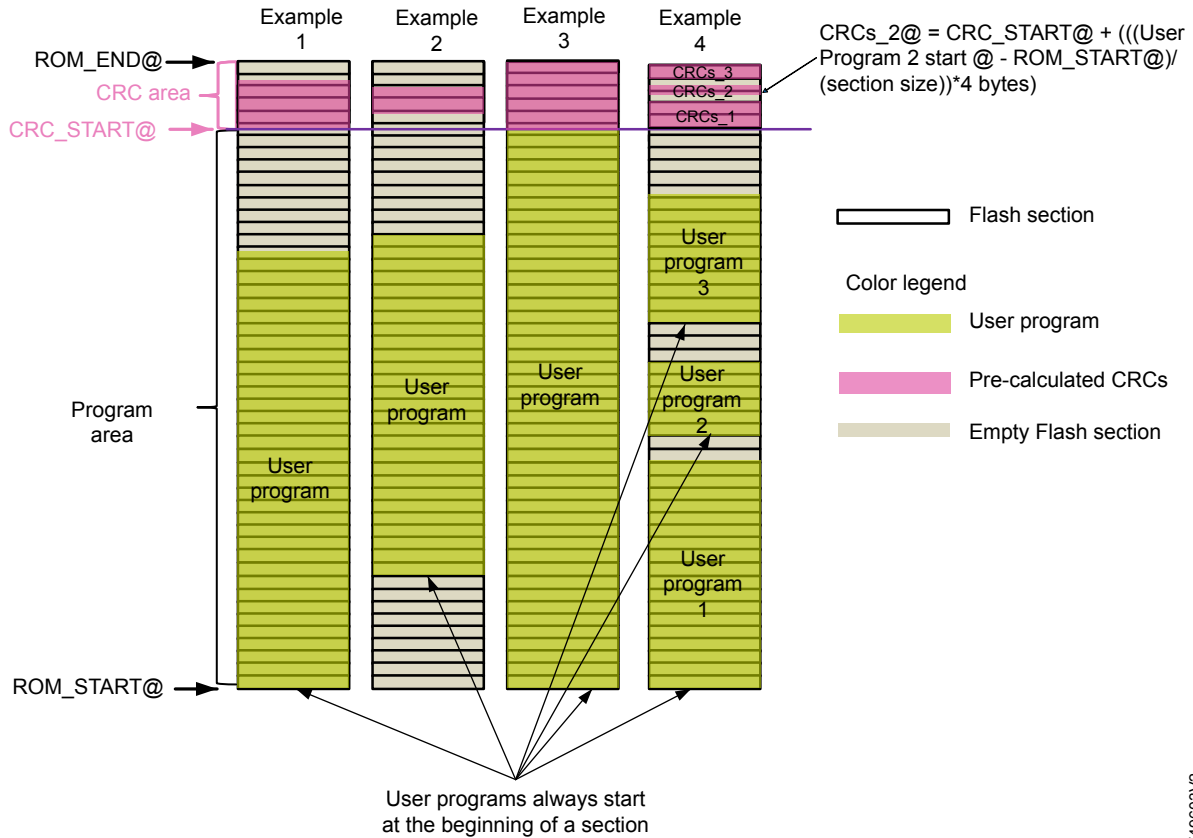

Figure 4. Flash memory test: CRC use cases versus program areas



DT49603V2

Use case descriptions illustrated in Figure 4:

- Example 1: the user program starts at the ROM\_START address, so CRCs are stored from the CRC\_START address.
- Example 2: the user program starts at the beginning of a section, but not at ROM\_START. The stored CRCs start at the right address of the CRC area.
- Example 3: the user program uses the full program area, so the last program data and the first CRC data are both stored in the same memory section (without any overlap).
- Example 4: the user program is defined in three separated areas. This requires three separated areas for the CRC data.

CRC start address computation:

- Real calculation:  

$$\text{CRC\_START address} = (\text{uint32\_t} *) (\text{ROM\_END} - 4 * (\text{ROM\_END} + 1 - \text{ROM\_START}) / (\text{FLASH\_SECTION\_SIZE} + 1);$$
with FLASH\_SECTION\_SIZE = 1024
- Textual translation:  

$$\text{CRC\_START} = \text{ROM\_END} - (\text{CRC size in bytes}) * (\text{number of the memory sections}) + 1$$

#### Flash memory test and interrupts

Flash memory *TM* is interruptible at any time.

#### 4.1.4 RAM tests

##### Principles

The RAM test concerns the embedded SRAM memories of STM32U0 series.

The following structures must be respected to provide correct configuration of the RAM test.

- Block: a continuous area of 16 bytes (RAM\_BLOCK\_SIZE), hard coded by the STL (no link with the memory physical sectors).
- Section: a continuous area of 128 bytes (RAM\_SECTION\_SIZE), hard coded by the STL.
- Subset: a continuous area, with the size being a multiple of two blocks and with a 32-bit aligned start address. A subset size is not necessarily a multiple of the section size, because the last part of a subset can be less than one section.
- Subset size =  $N * RAM\_SECTION\_SIZE + 2 * M * RAM\_BLOCK\_SIZE$ , where:
  - N is an integer  $\geq 0$
  - M is an integer  $0 \leq M < 4$ , when  $M > 0$ , the size of the last partial subset not aligned with section size.

The user application defines single or multiple subsets as well as their associated test sequences.

The STL implements a RAM memory test with the following principles (based on actual content of the user configuration structures):

- RAM tests are performed on RAM blocks defined by the user application
- RAM tests are performed either in a row (one shot), or partially in a single atomic step for a number of sections defined by the user application
- The test implementation is based on the March C- algorithm

The mandatory steps (for the user application) to perform RAM tests are:

- Initialization of RAM test
- Configuration of one or more RAM subsets
- Execution of the RAM test

Once all subsets are tested, the application must reset the RAM test module in order to perform the test again.

In the case of an STL\_ERROR / STL\_FAILED test result, the test module is stuck in the failed memory subset. In this case, deinitialize, initialize and reconfigure the RAM prior to running the test again.

### RAM test and interrupts

The RAM *TM* is interruptible at any time except during the execution of the smallest data granularity block as defined in [Section 4.2.5: STL interrupt masking time](#). This is when the STM32 interrupts and Cortex® exceptions with configurable priority are temporarily masked by default. The end user can, however, deactivate this masking by applying the dedicated STL\_ENABLE\_IT compilation switch (see [Section 5.5.2: Steps to build an application from scratch](#)). If the flag is activated, the end user is responsible for managing the interferences between the STL and the application software. These interfaces could possibly lead to false STL-error reports or application software malfunctions due to RAM content destruction by the test (see [March C- test principle and memory backup principle](#)).

### March C- test principle and memory backup principle

The RAM test is based on a March C- algorithm where memory is overwritten by specific patterns and then read back in specific orders. To restore the initial memory content, a backup process is enabled and performed by default. The backup process can be optionally disabled if it is not required. Refer to [Section 4.3.7: RAM backup buffer](#) for detailed information on the buffer control and allocation.

Figure 5. RAM test: usage

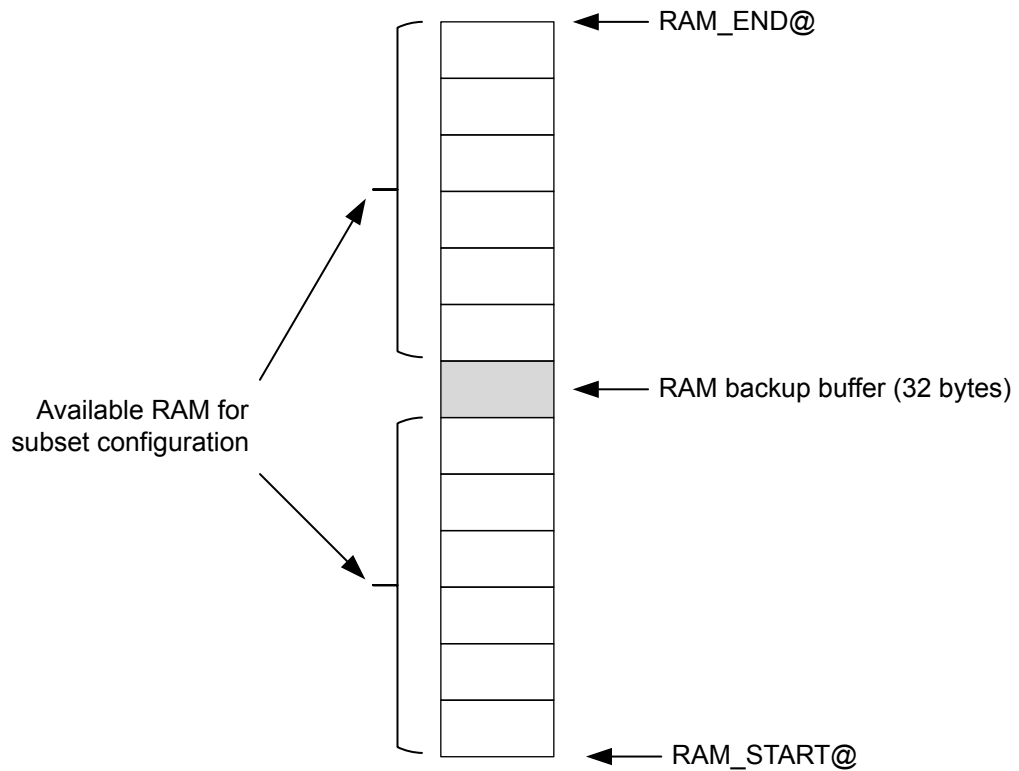

DT49050V1

## 4.2 STL performance data

The data is obtained with the following test set-up:

- STL library compilation details, described in Application: compilation process.
- Projects for performance tests are compiled with IAR Embedded Workbench® for Arm® (EWARM) toolchain v9.30.1
- Compiled software configuration with:
  - HCLK clock set to 48 MHz
  - Flash memory latency set to two wait states
  - Flash prefetch enabled
  - NUCLEO-STM32U031R8 (MB1932 rev B)

### 4.2.1 STL execution timings

A summary of the STL execution timings when an optimal default STL settings are applied is shown in the following table. The measurements for each API are detailed in [Section 9: STL: execution timing details](#).

**Table 3. STL execution timings, clock at 48 MHz**

| Tested module | Conditions  | Result in $\mu$ s |      |
|---------------|---|-------------------|------|
| CPU           | TM1L, TM7, TMCB<br>Default configuration (STL_ENABLE_IT not enabled):                     | 115               |      |
| Flash memory  | Default configuration (STL_SW_CRC not enabled):   | 1 Kbyte tested    | 74   |
|               |   | 17 Kbytes tested  | 972  |
|               | STL_SW_CRC enabled:   | 1 Kbyte tested    | 333  |
|               |   | 17 Kbytes tested  | 5416 |
| RAM           | Default configuration (neither STL_DISABLE_RAM_BCKUP_BUF, nor STL_ENABLE_IT are enabled): | 128 bytes tested  | 159  |
|               |   | 8 Kbytes tested   | 8203 |

#### 4.2.2 STL code and data size

The STL code and data sizes are detailed in the following table.

**Table 4. STL code size and data size (in bytes)**

| Configuration          | Module                    | Flash memory code  | Flash memory RO-data | R/W data |
|------------------------|---------------------------|--------------------|----------------------|----------|
| STL_SW_CRC not enabled | stl_user_param_template.o | -                  | 5                    | 44       |
|                        | stl_util.o                | 294 <sup>(1)</sup> | -                    | 8        |
|                        | stl_lib.a                 | 4660               | 1460                 | 184      |
| STL_SW_CRC enabled     | stl_user_param_template.o | -                  | 5                    | 44       |
|                        | stl_util.o                | 150 <sup>(1)</sup> | -                    | 4        |
|                        | stl_lib.a                 | 4660               | 1460                 | 184      |

1. When the software CRC calculation is applied, there are less code / functions compiled (the CRC hardware initialization is missing), consequently the object code size is reduced compared to the hardware CRC.

#### 4.2.3 STL stack usage

The minimum stack-available space required by the STL to execute available APIs is 200 bytes.

#### 4.2.4 STL heap usage

The STL never uses dynamic allocation, therefore the heap size is independent of the STL.

#### 4.2.5 STL interrupt masking time

The STM32 interrupts, and Cortex<sup>®</sup> exceptions with configurable priority, are masked multiple times by the STL during the execution of CPU TM7 and RAM tests. As shown in the following table, the maximum interrupt masking time is obtained for a RAM test.

**Table 5. STL maximum interrupt masking information**

| Tested module | Duration (max) in $\mu$ s | Comments   |
|---------------|---------------------------|--|
| RAM           | 14                        | Each execution of <code>STL_SCH_RunRamTM</code> function performs a series of interrupt masking during partial steps of the test at the following time durations: <ul style="list-style-type: none"> <li>• 14 <math>\mu</math>s for backup buffer +</li> <li>• 11 <math>\mu</math>s for the first RAM block to be tested</li> <li>• 13 <math>\mu</math>s for each middle RAM block to be tested<sup>(1)</sup></li> <li>• 12 <math>\mu</math>s for the last RAM block to be tested</li> </ul> |
| CPU TM7       | 10                        | Masked twice for 10 $\mu$ s and 9 $\mu$ s  |

1. Number of RAM blocks (multiple of two `RAM_BLOCK_SIZE` is required) involved with each RAM test execution depends on content of user structures (size of defined subset(s) versus atomic step – see [Section 4.1.4: RAM tests](#))

### 4.3 STL user constraints

The end user needs to consider interference between the application and the *STL*. The consequences of ignoring this are possible false *STL* error reporting, and/or application software execution issues.

Accordingly, to prevent any interference the application software and the *STL* integration must comply with each constraint listed in this section.

#### 4.3.1 Privileged-level

The CPU TM7 and the RAM TM must be executed with privileged level, in order to be able to modify certain core registers (for example the PRIMASK register) else these TMs return `STL_ERROR`.

#### 4.3.2 RCC resources

During *STL* execution, the RCC is configured to always provide a clock to the *CRC* hardware unit during *STL* initialization and optionally during *STL* Flash test module execution. This means that:

- when the *STL* returns, it restores the user RCC clock setting (enabled or disabled) for the *CRC* unit.
- the user application should be careful when configuring the RCC during *STL* execution by saving/restoring the *STL* settings.

#### 4.3.3 CRC resources

The STM32 *CRC* hardware unit is used during *STL* execution in two different cases:

- During execution of *STL* initialization (function `STL_SCH_Init`), the use of the *CRC* hardware unit in this phase cannot be modified by the application software, so the `STL_SW_CRC` flag has no impact during execution of the `STL_SCH_Init` function.
- During execution of the flash memory test module, the application can choose between hardware and software calculation of the *CRC* checksums by means of the `STL_SW_CRC` flag. By default, hardware *CRC* is used (the `STL_SW_CRC` flag is disabled).

The use of hardware *CRC* means that:

- Before calling the *STL*, the user must save any specific *CRC* unit configuration. The user configuration has to be restored after the *STL* execution.
- During the *STL* execution, the hardware unit is configured and used for *STL* needs (the user application must save/restore the *STL* settings when using the unit while interrupting the *STL* execution).

#### 4.3.4 Interrupt management

##### Escalation mechanism - Arm® Cortex® behavior reminder

When the *STL* disables STM32 interrupts, and Cortex® exceptions with configurable priority, remember that an Arm® Cortex® escalation to `HardFault` might occur. In this case, the `HardFault` handler is called instead of the fault handler.

### Interrupt and CPU TM7

By default, the STM32 interrupts and Cortex® exceptions with configurable priority are temporarily masked during the *CPU TM7* execution within smallest data granularity (a few instruction blocks), except if the user application activates the `STL_ENABLE_IT` compilation switch (see [Section 5.5.2: Steps to build an application from scratch](#)). If the `STL_ENABLE_IT` flag is activated, the correct STL CPU TM7 behavior is not guaranteed. The end user is responsible for managing interferences between the *STL* and its application software that could lead the *STL* to generate false test error reporting or not to detect hardware failures.

### Interrupt and RAM March C- tests

By default, the STM32 interrupts and Cortex® exceptions with configurable priority are masked during the *RAM March C-* tests, except if the user application activates the `STL_ENABLE_IT` compilation switch (see [Section 5.5.2: Steps to build an application from scratch](#)).

If the `STL_ENABLE_IT` flag is activated:

- The correct *STL RAM* test behavior is not guaranteed, as the application may overwrite the STL-tested *RAM* content during its interrupt treatment. The end user is responsible for managing interferences between the *STL* and its application software that could lead the *STL* to generate false *RAM* test error reporting.
- The behavior of the user application software can be compromised. Wrong data may be read or used from *RAM* locations that are being modified by the *STL March C-* test.

### Interrupt and general purpose registers

During *STL* execution, the application must save and restore the general-purpose registers in the STM32 interrupt and Cortex® exception with configurable priority service routine to ensure correct *STL* behavior and prevent any false error reporting.

### How *STL* masks the interrupts

To mask the interrupts, the *STL* sets the `PRIMASK` register bit to 1. Setting this bit to 1 boosts the current execution priority to 0, preventing the activation of all exceptions with configurable priority. Thus when the current execution priority is boosted to a particular value, all exceptions with a lower or equal priority are masked.

#### 4.3.5 DMA

The application must manage the DMA to avoid unwanted accesses to the *RAM* bank during the *STL March C-* test. In this case:

- DMA writes can disturb the *STL* test causing false error reporting
- DMA reads can return wrong data due to *STL* overwrites to DMA dedicated *RAM* sections.

#### 4.3.6 Supported memories

The *STL* memory tests provided (*Flash TM* and *RAM TM*) must only be executed on STM32 internal embedded memories. The *STL* library flow must be executed from the internal embedded memory only.

#### 4.3.7 RAM backup buffer

The backup process is enabled by default during *RAM* tests to preserve the *RAM* content. The user must then reserve a specific area for the *RAM* backup buffer at compilation time which must be allocated outside *RAM* subset configuration. There is only one *RAM* backup buffer defined for the test. The *RAM* backup buffer area is also tested by the *March C-* algorithm each time a *RAM* run test is called (prior to any subset defined by the user is tested).

The backup process can be optionally disabled either permanently by activating the compilation switch `STL_DISABLE_RAM_BCKUP_BUF` (see [Section 5.5.2: Steps to build an application from scratch](#)) or temporarily suppressed by specific control sequence (see note below). In this case, it is the responsibility of the end-user to guarantee that the application software does not consume data destroyed by the *March C-* test. This option can be used to speed up testing of those *RAM* areas where users do not need to preserve the memory content.

**Note:** For a temporary suppression of the RAM backup buffer, the user must follow a set sequence:

1. Change the `STL_pRamTmBckUpBuf` variable value to overwrite it by `NULL`, while keeping a backup of the original value (default value stored by the STL).
2. The RAM test must then be restarted. To do so the user can use one of the APIs which force the RAM test into either `RAM_IDLE` or `RAM_INIT` state (see state diagrams in [Section 7.3: State machines](#)).

To remove the backup suppression, the user must perform the same steps as above while restoring the default value of `STL_pRamTmBckUpBuf` to its original value and reinitialize the RAM test.

### 4.3.8 Memory mapping

Due to the RAM test module and March C method design, the user must ensure that the “read only” data of the STL is located in the flash memory. This must be done via a proper adaptation of the associated linker file .

The examples below are for EWARM and STM32CubeIDE.

#### EWARM .icf file adaptation example

```
place in ROM_region { readonly };
```

#### STM32CubeIDE .ld file adaptation example

```
.rodata :
{
.....
} >ROM
```

**Note:** Usually the default configuration locates “read only” data in flash memory.

### 4.3.9 Processor mode

The *STL CPU* TM7 must be executed in thread mode in order to set the active stack pointer to the process stack pointer. If the *STL* is not executed in thread mode, the *CPU* TM7 returns `STL_ERROR`.

## 4.4 End-user integration tests

This section describes the mandatory tests to be executed by the end user during the verification phase. These tests guarantee that the *STL* is correctly integrated in the application software.

### 4.4.1 Test 1: correct STL execution

The end user must use the expected function-return value and the expected test-module result value (see [Section 7.2: User APIs](#)) to check that each planned diagnostic function has been correctly executed. This concerns both the test modules execution and all their configuration actions.

### 4.4.2 Test 2: correct STL error-message processing

The end user must check that any error information produced by the *STL* function-return and test-module result values is correctly interpreted as unexpected behavior, and correctly handled in its application software. Error information refers to values different to the expected value, see [Section 7.2: User APIs](#)). During the verification, the artificial-failing feature must be used to emulate the generation of incorrect test-module result values related to associated individual software diagnostics (*CPU* tests, RAM test, flash memory test), for each of the individual functions used.

This process cannot be considered as an exhaustive simulation of actual *CPU* failures on real devices but rather a testing interface of the implemented *APIs*.

**Note:** In some circumstances, experts performing the safety assessment of final systems embedding the *STL* might require exhaustive simulation to demonstrate *STL* capability to capture corruption of STM32 registers or memories injected intentionally during debugging the *STL* code. To perform these tests is practically impossible for any end user due to *STL* object delivery format. This specific testing was done for all the provided *TMs* during the *STL* certification process and its passing is recorded at internal test reports and guaranteed by the valid certificate issued for this *ST* firmware.



## 5 Package description

This section details the X-CUBE-CLASSB-U0 expansion package content and its correct use.

### 5.1 General description

X-CUBE-CLASSB-U0 is a software expansion package for STM32U0 series microcontrollers.

It provides a complete solution that helps end customers to build a safety application:

- An application-independent software test library is available:
  - partly as object code: `STL_Lib.a`, the library itself
  - partly as source file: `stl_user_param_template.c` and `stl_util.c`
  - with three header files: `stl_stm32_hw_config.h`, `stl_user_api.h`, and `stl_util.h`
- A user application example, available as source code.

X-CUBE-CLASSB-U0 has been ported on the products listed in [Section 3.2: Supported products](#).

The software expansion package includes a sample application that the developer can use to start experimenting with the code. It is provided as a zip archive containing both source code and library.

The following integrated development environments are supported:

- IAR Embedded Workbench® for Arm® (EWARM)
- Keil® microcontroller development kit (MDK-ARM)
- STM32CubeIDE.

### 5.2 Architecture

The components of the X-CUBE-CLASSB-U0 expansion package are illustrated in [Figure 6](#).

Figure 6. Software architecture overview

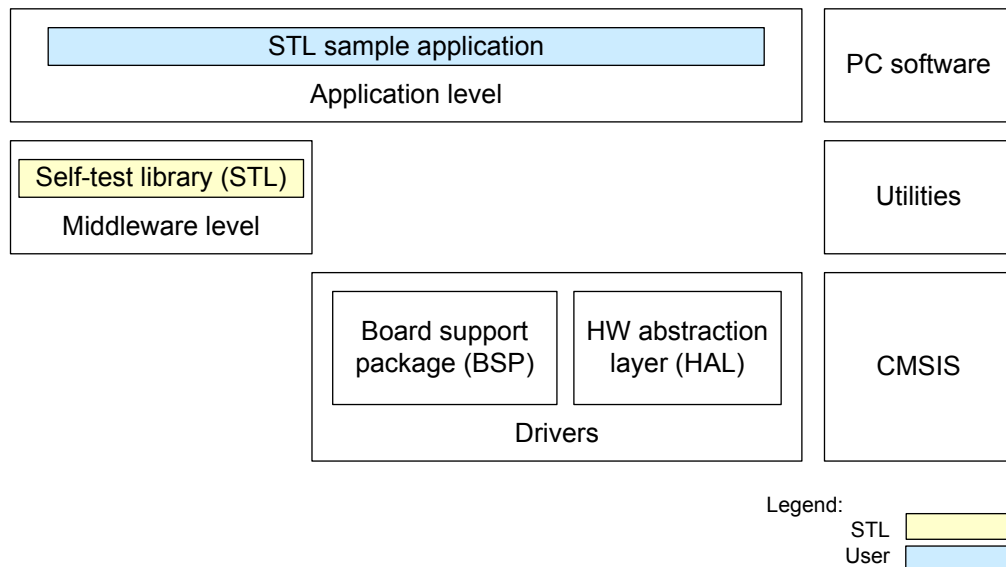

DT49051V1

#### 5.2.1 STM32Cube HAL

The *HAL* driver layer provides a simple, generic, multi-instance set of *APIs* (application programming interfaces) to interact with the upper layers (application, libraries, and stacks).

It comprises generic and extension *APIs*. It is directly built around a generic architecture and allows the layers that are built upon, such as the middleware layer, to implement their functionalities without dependencies on the specific hardware configuration of a given microcontroller.

This structure improves the library code re-usability and guarantees an easy portability to other devices.

### 5.2.2 Board support package (BSP)

The software package needs to support the peripherals on the STM32 boards, apart from the MCU. This software is included in the board support package (BSP). This is a limited set of *APIs* that provides a programming interface for some specific board components, such as the LED and the user button.

### 5.2.3 STL

A significant part of the *STL*, available at middleware level, is a black box that manages the software-based diagnostic test. It is independent from the *HAL*, *BSP*, and *CMSIS*, even if the *STL* integration example relies on some *HAL* drivers.

### 5.2.4 User application example

Reference projects provided in the example show how to integrate a possible sequence of the *STL* test module calls into an application when adopting different IDEs, verify the returns of the *APIs*, and emulate their failure responses artificially. Additionally, a specific module for testing the clock system by applying a monitoring method compliant with the "Class B" standard requirements is included with a full source code to extend the available library set. It demonstrates how the library can be extended by specific tests or modules entirely defined by the end user.

The example also shows a possible way to differentiate between the overall initial startup test and the sequence of partial tests performed periodically during application runtime.

### 5.2.5 STL integrity

The integrity of the *STL* content is ensured by hash SHA-256.

## 5.3 Folder structure

A top-level view of the structure is shown in Figure 7.

Figure 7. Project file structure

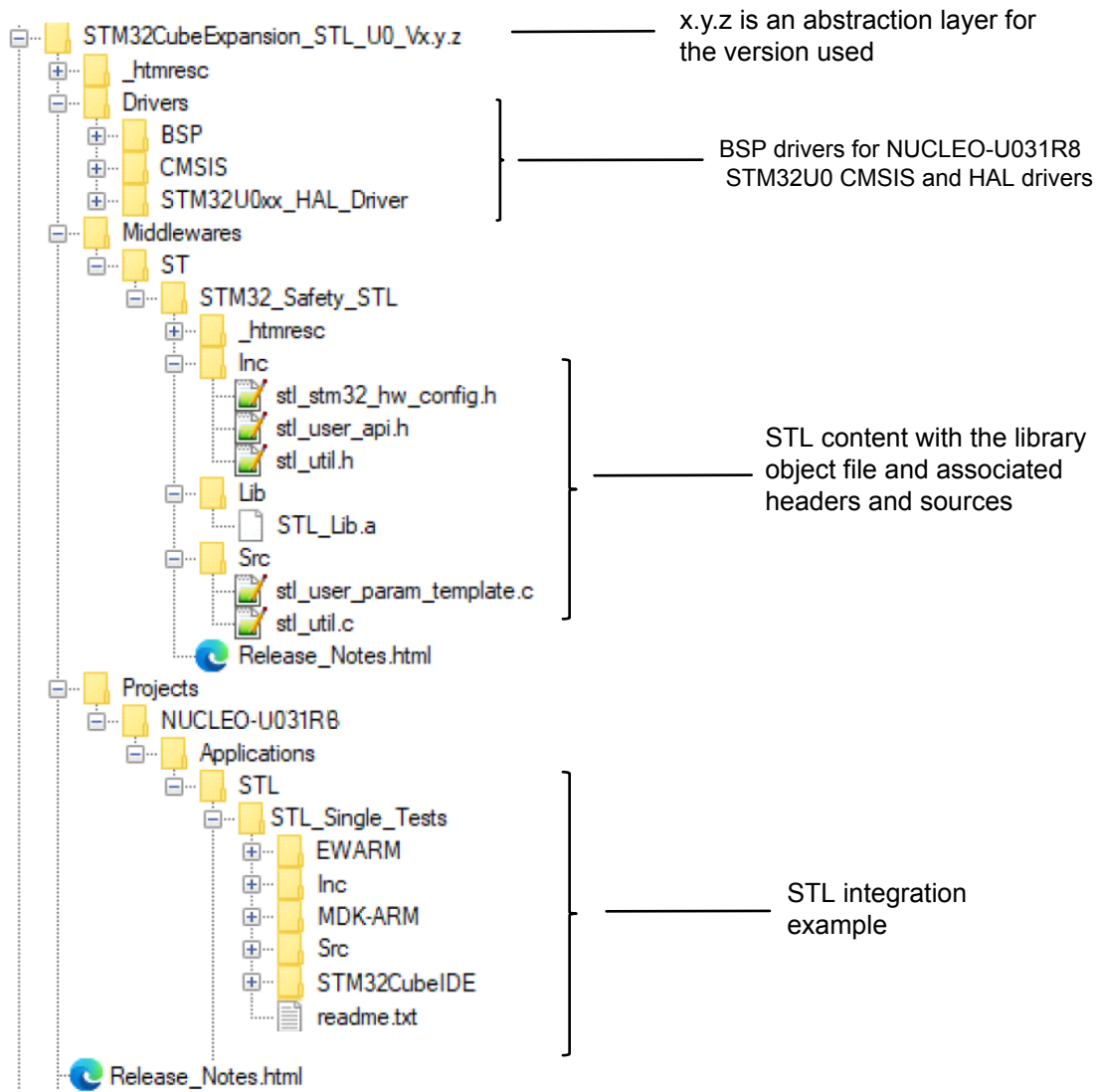

DT74923V1

## 5.4 APIs

### 5.4.1 Compliance

#### Interface compliance

The library part of the *STL*, not delivered in source code, has been compiled with IAR Embedded Workbench® for Arm v9.30.1. The compilation is done with `--aeabi` and `--guard_calls` compilation options to fulfill AEABI compliance as described in “AEABI compliance” of the EWARM help section.

To comply with the IEC 61508 functional safety standard, the industrial version of the self test library (X-CUBE-STL) certified by TÜV was compiled by safety certified EWARMFS version of the IAR™ compiler exclusively. Sources of this X-CUBE-CLASSB self test library dedicated to home appliances are based on a subset of modules taken from the industrial version of the library and have been adapted to comply with the IEC 60730-1 standard. This library can be linked-against any standard C-compiler.

### Safety guidelines

To fulfill the safety guidelines compliance as described in the IAR Embedded Workbench® safety guide (advice 2.1-1, 2.2-5, 2.4-1a and 5.4-3) and the Keil® safety manual (§4.9.2), the compliance is done with `--strict`, `--remarks`, `--require_prototypes` and `--no_unaligned_access` compilation options.

### Library compliance

The library part of the *STL* (not delivered in source code) is compliant with C standard library ISO C99. It has been compiled with the IAR™ option. Language C dialect = Standard C.

### Arm® compiler C toolchain vendor/version independency

The *STL* user *API* refers only to the “`uint32_t`” and “`enum`” C types:

- “`uint32_t`” C type is a fixed type size of 32 bits according to C standard C99
- “`enum`” C type size, according to C standard C99, is defined by the implementation. It must be able to represent the values of all the enumeration members. In the *STL* interface, the `enum` type values are unsigned integers, smaller than or equal to  $(2^{32} - 1)$ . The user must ensure that the `enum` type value can hold a 32-bit value.

## 5.4.2 Dependency

The *STL* library calls the `memset` standard C library function.

Furthermore, the IAR™ EWARM toolchain compiler is used to compile the *STL* library. This compiler may, under some circumstances, call the following standard C library functions: `memcpy`, `memset`, and `memclr`. This behavior is intrinsic to the IAR™ EWARM toolchain compiler. It is not possible to disable or avoid it.

As a result, when linking the *STL* library the user must ensure that these standard C library functions are defined. The user can use either the functions provided by the toolchain or the user ones.

## 5.4.3 Details

Detailed technical information about the available *APIs* can be found in [Section 7.2: User APIs](#), where the functions and parameters are described.

## 5.5 Application: compilation process

### 5.5.1 Steps to build a delivered STL example

Ensure the following steps are completed:

1. Install the ST *CRC* tool (see [Section 6.2.2: CRC tool set-up](#)) or other *CRC* tool that generate an adequate structure necessary for proper execution of the flash test.
2. Select a project example and open it.
3. Launch the build which compiles the binary and post build command invokes *CRC* tool to calculate and allocate the *CRC* results. In case of error, check the *CRC* tool path. For details see [Section 5.5.2: Steps to build an application from scratch](#).
4. Load the compiled binary.
5. Execute the example code.

Boot the board and check the result:

- LED toggles quickly and regularly: test result is as expected.
- LED toggles irregularly: there is an error.

If any test returns a failure result, the LED flashes once every 2 sec. If the *STL* detects a defense programming error, the LED flashes once every 4 sec.

The `FailSafe_Handler` procedure is then called with a parameter keeping the identification code of the failed module

**Note:** *The codes definitions are given in the `stl_user_api.h` file, in the case of a defensive programming failure, the `DEF_PROG_OFFSET` is added to the module code. User can adapt or extend the set of definitions applied by the STL example there.*

## 5.5.2 Steps to build an application from scratch

To build an application from scratch, follow the steps listed below:

1. Create new application project with a suitable directory structure and with all the appropriate packages. Use STM32CubeMX tool to make it automatically.
2. If any automated include options of the STL in the project is not supported by the STM32CubeMX tool, copy and paste the content of the `..Middleware\ST\STM32_Safety_STL` directory from the delivered STL example into the application project directories structure. Refer to [Section 5.3: Folder structure](#). In this case, modify the project setting manually while following the next steps:
  - Add all the STL source files located at the Src directory into the project.
  - Assign the Inc directory as an additional include path to be listed in the project settings.
  - Force the linker to include the library object file located at the Lib directory as an additional library.

**Note:** *This second step is necessary only when no automatic including option is supported by the CubeMX tool else it is fully performed by the tool - then there is no need for any manual intervention as described above - user can leave them out and continue by Step 3*

3. If needed, add the next optional preprocessor compilation switches at project settings:
  - Option to enable `STL_DISABLE_RAM_BCKUP_BUF`, if the RAM backup buffer is not used (in this case the RAM data of the tested subsets are destroyed). If not activated, the RAM backup buffer is used by default. In such cases, the "backup\_buffer\_section" section must be defined in the linker scatter file.
  - Option to enable `STL_SW_CRC`: this is where the user application selects the software CRC . If not activated, the hardware CRC calculation is used by default.
  - Option to enable `STL_ENABLE_IT`: this is where the user application enables the STM32 interrupts during the CPU TM7, and RAM test. If not activated, the interrupts are masked during these tests. See [Section 4.3.4: Interrupt management](#) and [Section 4.1.4: RAM tests](#).
4. Check the configuration of the flash memory density.  
It is mandatory to set the correct range of the memory for the project at `stl_user_param_template.c` file. Update the `STL_ROM_END_ADDR` there especially to ensure coherency with the associated linker scatter file and the CRC tool script (see step 6.).
5. Develop the user STL flow control. It is done by implementing the proper sequence of API calls repeated at periodical cycles, as required by the defined safety task.  
It is mandatory to ensure a proper filling of all the associated user structures to control the memory tests and apply a correct check of the STL return information. Refer to [Section 7: STL: User APIs and state machines](#).
6. Apply the CRC tool to build the CRC area content necessary for the CRC calculation. Refer to [Section 6.2.2: CRC tool set-up](#).  
Execute a proper command line of the STM32CubeProgrammer. This can be done automatically within the compilation process by invoking the IDE post build feature action as seen in [Figure 8](#) and [Figure 9](#).
7. Compile, load, and execute the binary.

Artificial failing APIs can be used to debug a correct behavior of the programmed STL flow if the STL detects a hardware failure.

Figure 8. IAR™ post-build actions screenshot

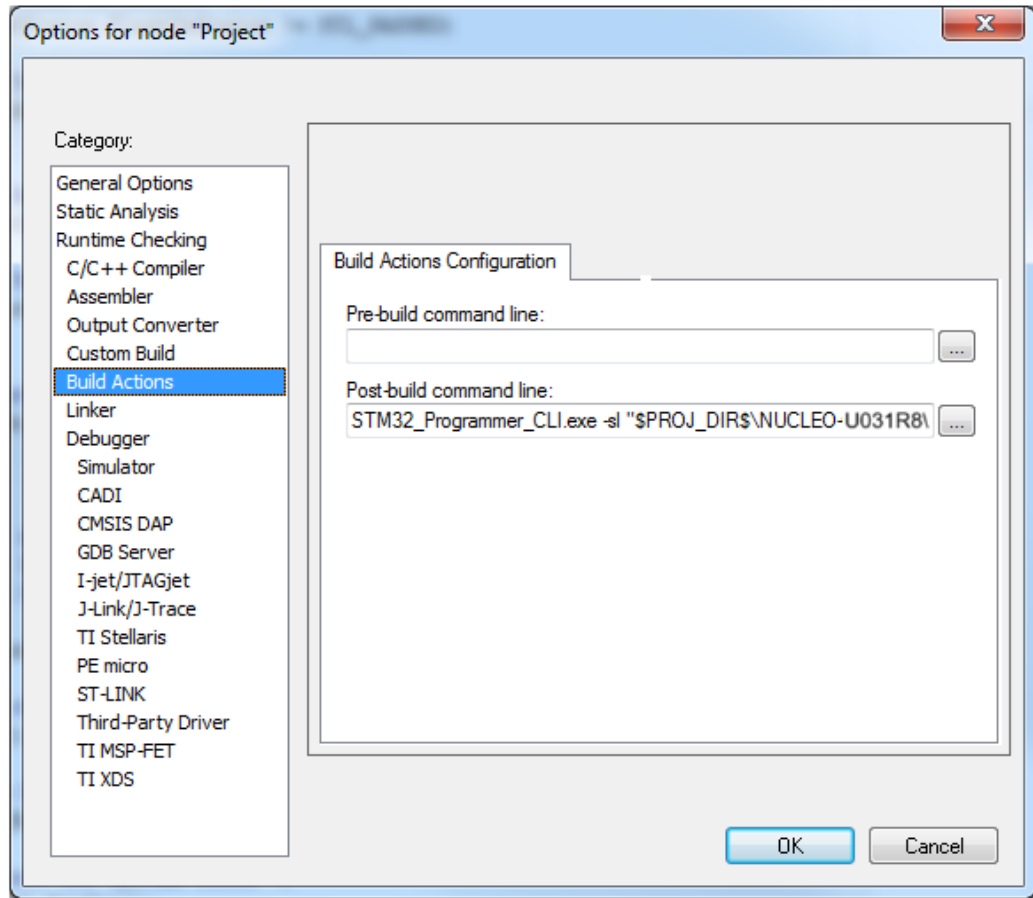

DT74931V1

Figure 9. CRC tool command line

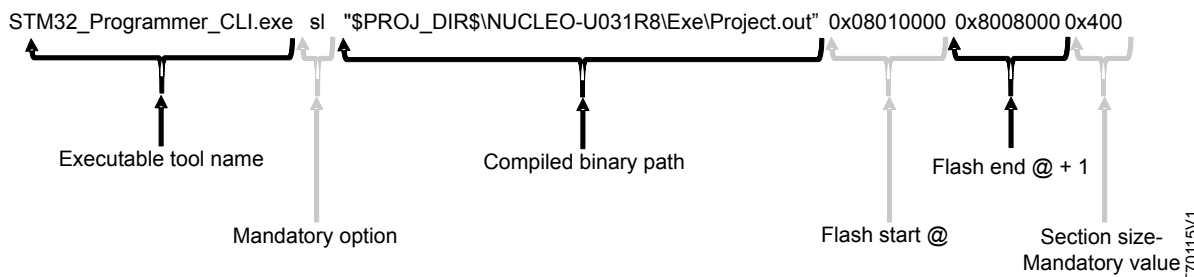

DT70115V1

## 6 Hardware and software environment setup

### 6.1 Hardware setup

The STM32 Nucleo boards provide an affordable and flexible way for users to try out new ideas and build prototypes with any STM32 microcontroller lines. The ARDUINO® connectivity support and ST morpho headers make it easy to expand the functionality of the STM32 Nucleo open development platform with a wide choice of specialized expansion boards. The STM32 Nucleo board does not require any separate probe as it integrates the ST-LINK/V2-1 debugger/programmer. The STM32 Nucleo boards come with the STM32 comprehensive software HAL library together with various packaged-software examples.

Details about the STM32 Nucleo boards are available from the <http://www.st.com/stm32nucleo> web page.

Figure 10. STM32 Nucleo board example

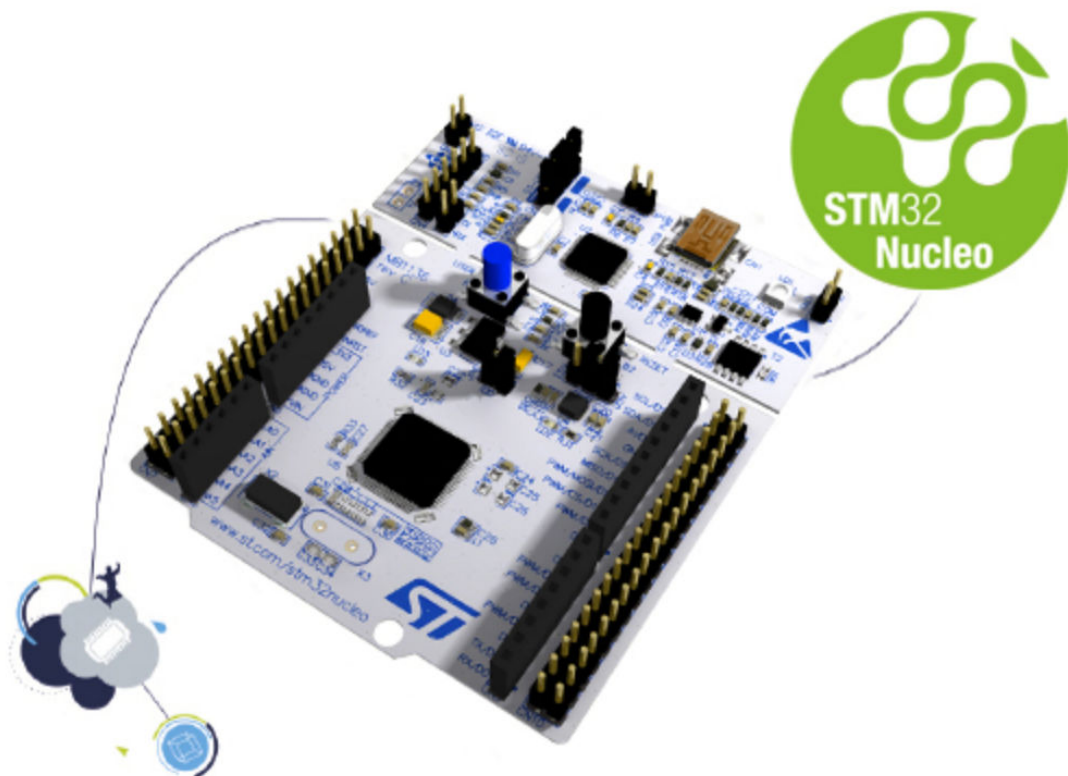

Note: This is a picture of a specimen Nucleo board and is not contractual

The following components are needed:

- NUCLEO-STM32U031R8 (MB1932 rev B) development board
- USB type A to Mini cable to connect the development board to the PC.

### 6.2 Software setup

This section lists the minimum requirements for the developer to set up the SDK, to run the sample scenario, and to customize applications.

#### 6.2.1 Development tool-chains and compilers

Select one of the *IDEs* supported by the STM32Cube software expansion package.

Read the system requirements and setup information provided by the selected *IDE* provider.

Check the projects `Release_Notes.html` file inside the release package, and refer to the chapter *IDE* compatibility, if it exists.

### 6.2.2 CRC tool set-up

ST provides a *CRC* tool, available as a single feature inside the STM32CubeProgrammer, used for flash memory testing. Other *CRC* tools can be used, provided they fulfill the requirements detailed in [Expected CRC precalculation](#).

Tool installation procedure:

1. Select STM32CubeProgrammer on the dedicated web page available on [www.st.com](http://www.st.com)
2. Install the package.

The easiest way is to add the tool path in the environment variable (computer administration rights are required). If not, the path must be added directly in the project for compilation, in the post-build option.



## 7 STL: User APIs and state machines

### 7.1 User structures

The structures are defined in `stl_user_api.h`. It is forbidden to change the content of this file.

Structures detailed hereafter are copies of the `stl_user_api.h` content:

```
typedef enum
{
    STL_OK = STL_OK_DEF, /* Scheduler function successfully executed */
    STL_KO = STL_KO_DEF /* Scheduler function unsuccessfully executed
                        (defensive programming error, checksum error). In this case
                        the STL_TmStatus_t values are not relevant */
} STL_Status_t; /* Type for the status return value of the STL function execution */
```

```
typedef enum
{
    STL_PASSED = STL_PASSED_DEF, /* Test passed. For Flash/RAM, test is passed and end of
                                configuration is also reached */
    STL_PARTIAL_PASSED = STL_PARTIAL_PASSED_DEF, /* Used only for RAM and Flash testing.
                                                Test passed, But end of Flash/RAM
                                                configuration not yet reached */
    STL_FAILED = STL_FAILED_DEF, /* Hardware error detection by Test Module */
    STL_NOT_TESTED = STL_NOT_TESTED_DEF, /* Initial value after a SW init, SW config,
                                         SW reset, SW de-init or value when Test Module
                                         not executed */
    STL_ERROR = STL_ERROR_DEF /* Test Module unsuccessfully executed (defensive programming
                              check failed) */
} STL_TmStatus_t; /* Type for the result of a Test Module */
```

```
typedef enum
{
    STL_CPU_TM1L_IDX = 0U, /* CPU Arm Core Test Module 1L index */
    STL_CPU_TM7_IDX, /* CPU Arm Core Test Module 7 index */
    STL_CPU_TMCB_IDX, /* CPU Arm Core Test Module Class B index */
    STL_CPU_TM_MAX /* Number of CPU Arm Core Test Modules */
} STL_CpuTmIndex_t; /* Type for index of CPU Arm Core Test
                   Modules */
```

```
typedef struct STL_MemSubset_struct
{
    uint32_t StartAddr; /* start address of Flash or RAM memory subset */
    uint32_t EndAddr; /* end address of Flash or RAM memory subset */

    struct STL_MemSubset_struct *pNext; /* pointer to the next Flash or RAM memory subset
                                         - to be set to NULL for the last subset */
} STL_MemSubset_t; /* Type used to define Flash
                   or RAM subsets to test */
```

```
typedef struct
{
    STL_MemSubset_t *pSubset; /* Pointer to the Flash or RAM subsets to test */
    uint32_t NumSectionsAtomic; /* Number of Flash or RAM sections to be tested
                                during an atomic test */
} STL_MemConfig_t; /* Type used to fully define Flash or RAM test configuration */
```

```
typedef struct
{
    STL_TmStatus_t aCpuTmStatus[STL_CPU_TM_MAX]; /* Array of forced status value
                                                  for CPU Test Modules */
    STL_TmStatus_t FlashTmStatus; /* Forced status value for Flash Test Module */
    STL_TmStatus_t RamTmStatus; /* Forced status value for RAM Test Module */
} STL_ArtifFailingConfig_t; /* Type used to force Test Modules status to a specific
                             value for each STL Test Module */
```

## 7.2 User APIs

The following APIs are declared in the file `stl_user_api.h`. It is forbidden to change the content of this file.

**Caution:** *For pointers defined by the user application and used as STL API parameters, the user application must set valid pointers, maintain pointer availability, and check the pointer integrity. The STL does not copy the pointer content, and accesses directly to the memory addresses defined by the application.*

*This applies during the overall STL execution. For example, the pointers to access the content of structures that keep the configuration of the memory tests must be maintained. They are still used by the `STL_SCH_run_xxx` functions, even if they are not always part of the input parameter list when an API associated with these tests is called.*

*For more details about proper API sequence calls see [Section 7.3: State machines](#) and [Section 8: Test examples](#).*

### 7.2.1 Common API

The following sections present details on common APIs.

#### 7.2.1.1 `STL_SCH_Init`

**Description:** initializes the scheduler. It can be used at any time to reinitialize the scheduler (it resets all tests).

**Declaration:** `STL_Status_t STL_SCH_Init(void)`.

**Table 6. `STL_SCH_Init` input information**

| Allowed states                               | Parameters |
|--|------------|
| CPU TMx: all<br>Flash TM: all<br>RAM TM: all | -          |

**Table 7. `STL_SCH_Init` output information**

| STL_Status_t return value |  | Returned state  |
|---------------------------|--|---|
| Value                     | Comments   |   |
| STL_OK                    | Function successfully executed   | CPU TMx: CPU_TMx_CONFIGURED<br>Flash TM: FLASH_IDLE<br>RAM TM: RAM_IDLE |
| STL_KO                    | Source of defensive programming error: <ul style="list-style-type: none"> <li>STL internal data corrupted</li> </ul> | No state change   |

Additional information: there is no specific CPU initialization function for CPU test modules.

**Note:** *This function uses hardware CRC as explained in [Section 4.3.3: CRC resources](#).*

### 7.2.2 CPU Arm® core testing APIs

#### 7.2.2.1 `STL_SCH_RunCpuTMx`

**Description:** runs one of the CPU test modules.

**Declaration:** `STL_Status_t STL_SCH_RunCpuTMx(STL_TmStatus_t *pSingleTmStatus)` where TMx can be one of TM1L, TM7 or TMCB.

**Table 8. STL\_SCH\_RunCpuTMx input information**

| Allowed states     | Parameters       |             |
|--------------------|------------------|-------------|
|                    | Value            | Comments    |
| CPU_TMx_CONFIGURED | *pSingleTmStatus | See Caution |

**Table 9. STL\_SCH\_RunCpuTMx output information**

| STL_Status_t return value |   | *pSingleTmStatus output |   | Returned state     |
|---------------------------|---|-------------------------|---|--------------------|
| Value                     | Comments  | Value                   | Comments  |                    |
| STL_OK                    | Function successfully executed  | STL_PASSED              | -   | CPU_TMx_CONFIGURED |
|                           |   | STL_FAILED              | -   |                    |
|                           |   | STL_ERROR               | Source of defensive programming error: <ul style="list-style-type: none"> <li>STL internal data corrupted</li> <li>Software is not executed with privileged level for CPU TM7</li> <li>Software is not executed in thread mode for CPU TM7</li> </ul> |                    |
| STL_KO                    | Possible source of defensive programming error: <ul style="list-style-type: none"> <li>pSingleTmStatus = NULL</li> <li>STL internal data corrupted</li> </ul> | Not relevant            | Value must not be used  | No state change    |

## 7.2.3 Flash memory testing APIs

### 7.2.3.1 STL\_SCH\_InitFlash

Description: initializes flash memory test.

Declaration: STL\_Status\_t STL\_SCH\_InitFlash(STL\_TmStatus\_t \*pSingleTmStatus)

**Table 10. STL\_SCH\_InitFlash input information**

| Allowed states                               | Parameters       |          |
|--|------------------|----------|
|  | Value            | Comments |
| FLASH_IDLE<br>FLASH_INIT<br>FLASH_CONFIGURED | *pSingleTmStatus | Caution  |

**Table 11. STL\_SCH\_InitFlash output information**

| STL_Status_t return value |   | *pSingleTmStatus output |                        | Returned state  |
|---------------------------|---|-------------------------|------------------------|-----------------|
| Value                     | Comments  | Value                   | Comments               |                 |
| STL_OK                    | Function successfully executed  | STL_NOT_TESTED          | -                      | FLASH_INIT      |
| STL_KO                    | Possible source of defensive programming error: <ul style="list-style-type: none"> <li>pSingleTmStatus = NULL</li> <li>STL internal data corrupted</li> </ul> | Not relevant            | Value must not be used | No state change |

**7.2.3.2 STL\_SCH\_ConfigureFlash**

**Description:** configures the flash memory test.

**Declaration:** `STL_Status_t STL_SCH_ConfigureFlash(STL_TmStatus_t *pSingleTmStatus, STL_MemConfig_t *pFlashConfig)`

**Table 12. STL\_SCH\_ConfigureFlash input information**

| Allowed states    | Parameter   |  |   |  |
|-------------------|---|--|---|--|
|                   | Value   | Comments   |   |  |
| FLASH_INIT        | *pSingleTmStatus  | See <a href="#">Caution</a>  |   |  |
|                   | *pFlashConfig   | Pointer to the flash memory configuration. See <a href="#">Caution</a> . |   |  |
|                   |   | Field  | Comments  |  |
|                   |   | *pSubset   | <ul style="list-style-type: none"> <li>Pointer to flash memory subset. See <a href="#">Caution</a></li> <li>A section cannot overlap with the CRC area</li> </ul> |  |
|                   |   |  | Field   | Comments   |
|                   |   |  | StartAddr   | <ul style="list-style-type: none"> <li>Start subset address in bytes</li> <li>Cannot be lower than ROM_START and higher than CRC_START address</li> </ul>  |
|                   |   |  | EndAddr   | <ul style="list-style-type: none"> <li>End subset address in bytes</li> <li>Cannot be lower than ROM_START and higher than CRC_START address</li> <li>Needs to be higher than StartAddr</li> </ul> |
| *pNext            | <ul style="list-style-type: none"> <li>Pointer to next flash memory subset. See <a href="#">Caution</a></li> <li>Must be set to NULL for the last subset</li> </ul>   |  |   |  |
| NumSectionsAtomic | <ul style="list-style-type: none"> <li>Number of flash memory sections to be tested during an atomic test</li> <li>Set to 1, as minimum (one section per test)</li> <li>If the value is higher than the number of sections in all subsets, all flash memory subsets are tested in one pass</li> </ul> |  |   |  |

**Table 13. STL\_SCH\_ConfigureFlash output information**

| STL_Status_t return value |  | *pSingleTmStatus output |  | Returned state   |
|---------------------------|--|-------------------------|--|------------------|
| Value                     | Comments   | Value                   | Comments   |                  |
| STL_OK                    | Function successfully executed   | STL_NOT_TESTED          | -  | FLASH_CONFIGURED |
|                           |  | STL_ERROR               | Possible source of defensive programming error: <ul style="list-style-type: none"> <li>• State not allowed</li> <li>• Wrong configuration detected</li> <li>• STL internal data corrupted</li> </ul> | No state change  |
| STL_KO                    | Possible source of defensive programming error: <ul style="list-style-type: none"> <li>• pSingleTmStatus = NULL</li> <li>• pFlashConfig = NULL</li> <li>• STL internal data corrupted</li> </ul> | Not relevant            | Value must not be used   | No state change  |

Additional information: in the case of a return value set to STL\_KO or \*pSingleTmStatus set to STL\_ERROR, the flash memory configuration is not applied.

**7.2.3.3**
**STL\_SCH\_RunFlashTM**

Description: runs flash memory test.

Declaration: STL\_Status\_t STL\_SCH\_RunFlashTM(STL\_TmStatus\_t \*pSingleTmStatus)

**Table 14. STL\_SCH\_RunFlashTM input information**

| Allowed states   | Parameters       |             |
|------------------|------------------|-------------|
|                  | Value            | Comments    |
| FLASH_CONFIGURED | *pSingleTmStatus | See Caution |

**Table 15. STL\_SCH\_RunFlashTM output information**

| STL_Status_t return value |   | *pSingleTmStatus output |   | Returned state   |
|---------------------------|---|-------------------------|---|------------------|
| Value                     | Comments  | Value                   | Comments  |                  |
| STL_OK                    | Function successfully executed  | STL_PASSED              | -   | FLASH_CONFIGURED |
|                           |   | STL_PARTIAL_PASSED      | -   | FLASH_CONFIGURED |
|                           |   | STL_FAILED              | -   | FLASH_CONFIGURED |
|                           |   | STL_NOT_TESTED          | All subsets are already tested  | FLASH_CONFIGURED |
|                           |   | STL_ERROR               | Possible source of defensive programming error: <ul style="list-style-type: none"> <li>State not allowed</li> <li>Configuration corrupted</li> <li>STL internal data corrupted</li> </ul> | No state change  |
| STL_KO                    | Possible source of defensive programming error: <ul style="list-style-type: none"> <li>pSingleTmStatus = NULL</li> <li>STL internal data corrupted</li> </ul> | Not relevant            | Value must not be used  | No state change  |

**7.2.3.4**
**STL\_SCH\_ResetFlash**

Description: resets flash memory test.

Declaration: STL\_Status\_t STL\_SCH\_ResetFlash(STL\_TmStatus\_t \*pSingleTmStatus)

**Table 16. STL\_SCH\_ResetFlash input information**

| Allowed states   | Parameters       |             |
|------------------|------------------|-------------|
|                  | Value            | Comments    |
| FLASH_CONFIGURED | *pSingleTmStatus | See Caution |

**Table 17. STL\_SCH\_ResetFlash output information**

| STL_Status_t return value |   | *pSingleTmStatus output |   | Returned state   |
|---------------------------|---|-------------------------|---|------------------|
| Value                     | Comments  | Value                   | Comments  |                  |
| STL_OK                    | Function successfully executed  | STL_NOT_TESTED          | Configuration successfully applied  | FLASH_CONFIGURED |
|                           |   | STL_ERROR               | Possible source of defensive programming error: <ul style="list-style-type: none"> <li>State not allowed</li> <li>Configuration corrupted</li> <li>STL internal data corrupted</li> </ul> | No state change  |
| STL_KO                    | Possible source of defensive programming error: <ul style="list-style-type: none"> <li>pSingleTmStatus = NULL</li> <li>STL internal data corrupted</li> </ul> | Not relevant            | Value must not be used  | No state change  |

Additional information

- Once all subsets are tested, the user needs to reset the test module to perform the flash memory test again.
- In the case of a return value set to STL\_KO or \*pSingleTmStatus set to STL\_ERROR, the flash memory reset is not applied.

**7.2.3.5**
**STL\_SCH\_DeInitFlash**

Description: deinitializes flash memory test.

Declaration: STL\_Status\_t STL\_SCH\_DeInitFlash(STL\_TmStatus\_t \*pSingleTmStatus)

**Table 18. STL\_SCH\_DeInitFlash input information**

| Allowed states                               | Parameters       |             |
|--|------------------|-------------|
|  | Value            | Comments    |
| FLASH_IDLE<br>FLASH_INIT<br>FLASH_CONFIGURED | *pSingleTmStatus | See Caution |

**Table 19. STL\_SCH\_DeInitFlash output information**

| STL_Status_t return value |   | *pSingleTmStatus output |                        | Returned state  |
|---------------------------|---|-------------------------|------------------------|-----------------|
| Value                     | Comments  | Value                   | Comments               |                 |
| STL_OK                    | Function successfully executed  | STL_NOT_TESTED          | -                      | FLASH_IDLE      |
| STL_KO                    | Possible source of defensive programming error: <ul style="list-style-type: none"> <li>• pSingleTmStatus = NULL</li> <li>• STL internal data corrupted</li> </ul> | Not relevant            | Value must not be used | No state change |

**7.2.4**
**RAM testing APIs**
**7.2.4.1**
**STL\_SCH\_InitRam**

Description: initializes the RAM test.

Declaration: STL\_Status\_t STL\_SCH\_InitRam(STL\_TmStatus\_t \*pSingleTmStatus).

**Table 20. STL\_SCH\_InitRam input information**

| Allowed states                         | Parameters       |             |
|--|------------------|-------------|
|  | Value            | Comments    |
| RAM_IDLE<br>RAM_INIT<br>RAM_CONFIGURED | *pSingleTmStatus | See Caution |

**Table 21. STL\_SCH\_InitRam output information**

| STL_Status_t return value |   | *pSingleTmStatus output |                        | Returned state  |
|---------------------------|---|-------------------------|------------------------|-----------------|
| Value                     | Comments  | Value                   | Comments               |                 |
| STL_OK                    | Function successfully executed  | STL_NOT_TESTED          | -                      | RAM_INIT        |
| STL_KO                    | Possible source of defensive programming error: <ul style="list-style-type: none"> <li>• pSingleTmStatus = NULL</li> <li>• STL internal data corrupted</li> </ul> | Not relevant            | Value must not be used | No state change |

**7.2.4.2 STL\_Status\_t STL\_SCH\_ConfigureRam**

**Description:** Description: configures the RAM test.

**Declaration:** STL\_Status\_t STL\_SCH\_ConfigureRam(STL\_TmStatus\_t \*pSingleTmStatus, STL\_MemConfig\_t \*pRamConfig)

**Table 22. STL\_SCH\_ConfigureRam input information**

| Allowed states | Parameter  |   |  |
|----------------|--|---|--|
|                | Value  | Comments  |  |
| RAM_INIT       | *pSingleTmStatus   | See <a href="#">Caution</a>   |  |
|                | *pRamConfig  | This pointer contains the RAM configuration. See <a href="#">Caution</a>  |  |
|                |  | Field   | Comments   |
|                |  |   | <ul style="list-style-type: none"> <li>• Pointer to RAM subset. See <a href="#">Caution</a></li> <li>• A subset cannot overlap with the RAM backup buffer if defined</li> </ul>  |
|                |  | Field   | Comments   |
|                |  | StartAddr   | <ul style="list-style-type: none"> <li>• Start subset address in bytes</li> <li>• Start address must be 32-bit aligned</li> <li>• RAM subset must be inside RAM area</li> <li>• Cannot be lower than RAM_START and higher than RAM_END address</li> </ul>                                    |
|                |  | EndAddr   | <ul style="list-style-type: none"> <li>• End subset address in bytes</li> <li>• Higher than StartAddr</li> <li>• Cannot be lower than RAM_START and higher than RAM_END address</li> <li>• Subset size (EndAddr - StartAddr) needs to be multiple of 2 * RAM_BLOCK_SIZE, 32 bytes</li> </ul> |
| *pNext         | <ul style="list-style-type: none"> <li>• Pointer to next RAM subset. See <a href="#">Caution</a></li> <li>• Must be set to NULL for the last subset</li> </ul> |   |  |
|                | NumSectionsAtomic  | <ul style="list-style-type: none"> <li>• Number of RAM sections to be tested during an atomic test</li> <li>• Set to 1, as minimum (one section per test)</li> <li>• If the value is higher than the number of sections in all subsets, all RAM subsets are tested in one pass</li> </ul> |  |



**Table 23. STL\_SCH\_ConfigureRam output information**

| STL_Status_t return value |  | *pSingleTmStatus output |  | Returned state  |
|---------------------------|--|-------------------------|--|-----------------|
| Value                     | Comments   | Value                   | Comments   |                 |
| STL_OK                    | Function successfully executed   | STL_NOT_TESTED          | -  | RAM_CONFIGURED  |
|                           |  | STL_ERROR               | Possible source of defensive programming error: <ul style="list-style-type: none"> <li>• State not allowed</li> <li>• Wrong configuration detected</li> <li>• STL internal data corrupted</li> </ul> | No state change |
| STL_KO                    | Possible source of defensive programming error: <ul style="list-style-type: none"> <li>• pSingleTmStatus = NULL</li> <li>• pRamConfig = NULL</li> <li>• STL internal data corrupted</li> </ul> | Not relevant            | Value must not be used   | No state change |

Additional information: in the case of a return value set to STL\_KO or \*pSingleTmStatus set to STL\_ERROR, the RAM configuration is not applied.

### 7.2.4.3

#### STL\_SCH\_RunRamTM

Description: runs the RAM test.

Declaration: STL\_Status\_t STL\_SCH\_RunRamTM(STL\_TmStatus\_t \*pSingleTmStatus)

**Table 24. STL\_SCH\_RunRamTM input information**

| Allowed states | Parameters       |             |
|----------------|------------------|-------------|
|                | Value            | Comments    |
| RAM_CONFIGURED | *pSingleTmStatus | See Caution |

**Table 25. STL\_SCH\_RunRamTM output information**

| STL_Status_t return value |   | *pSingleTmStatus output |   | Returned state  |
|---------------------------|---|-------------------------|---|-----------------|
| Value                     | Comments  | Value                   | Comments  |                 |
| STL_OK                    | Function successfully executed  | STL_PASSED              | -   | RAM_CONFIGURED  |
|                           |   | STL_PARTIAL_PASSED      | -   | RAM_CONFIGURED  |
|                           |   | STL_FAILED              | -   | RAM_CONFIGURED  |
|                           |   | STL_NOT_TESTED          | All subsets are already tested  | RAM_CONFIGURED  |
|                           |   | STL_ERROR               | Possible source of defensive programming error: <ul style="list-style-type: none"> <li>State not allowed</li> <li>Configuration corrupted</li> <li>STL internal data corrupted</li> </ul> | No state change |
| STL_KO                    | Possible source of defensive programming error: <ul style="list-style-type: none"> <li>pSingleTmStatus = NULL</li> <li>STL internal data corrupted</li> </ul> | Not relevant            | Value must not be used  | No state change |

**7.2.4.4**
**STL\_Status\_t STL\_SCH\_ResetRam**

Description: resets the RAM test.

Declaration: STL\_Status\_t STL\_SCH\_ResetRam(STL\_TmStatus\_t \*pSingleTmStatus)

**Table 26. STL\_SCH\_ResetRam input information**

| Allowed states | Parameters       |                             |
|----------------|------------------|-----------------------------|
|                | Value            | Comments                    |
| RAM_CONFIGURED | *pSingleTmStatus | See <a href="#">Caution</a> |

**Table 27. STL\_SCH\_ResetRam output information**

| STL_Status_t return value |   | *pSingleTmStatus output |   | Returned state  |
|---------------------------|---|-------------------------|---|-----------------|
| Value                     | Comments  | Value                   | Comments  |                 |
| STL_OK                    | Function successfully executed  | STL_NOT_TESTED          | Configuration successfully applied  | RAM_CONFIGURED  |
|                           |   | STL_ERROR               | Possible source of defensive programming error: <ul style="list-style-type: none"> <li>State not allowed</li> <li>Configuration corrupted</li> <li>STL internal data corrupted</li> </ul> | No state change |
| STL_KO                    | Possible source of defensive programming error: <ul style="list-style-type: none"> <li>pSingleTmStatus = NULL</li> <li>STL internal data corrupted</li> </ul> | Not relevant            | Value must not be used  | No state change |

**Additional information**

- Once all subsets are tested, the user needs to reset the test module to perform the RAM test again.
- In the case of a return value set to STL\_KO or \*pSingleTmStatus set to STL\_ERROR, the RAM reset is not applied.

**7.2.4.5**
**STL\_SCH\_DeInitRam**

**Description:** deinitializes the RAM test.

**Declaration:** STL\_Status\_t STL\_SCH\_DeInitRam(STL\_TmStatus\_t \*pSingleTmStatus)

**Table 28. STL\_SCH\_DeInitRam input information**

| Allowed states                         | Parameters       |             |
|--|------------------|-------------|
|  | Value            | Comments    |
| RAM_IDLE<br>RAM_INIT<br>RAM_CONFIGURED | *pSingleTmStatus | See Caution |

**Table 29. STL\_SCH\_DeInitRam output information**

| STL_Status_t return value |   | *pSingleTmStatus output |                        | Returned state  |
|---------------------------|---|-------------------------|------------------------|-----------------|
| Value                     | Comments  | Value                   | Comments               |                 |
| STL_OK                    | Function successfully executed  | STL_NOT_TESTED          | -                      | RAM_IDLE        |
| STL_KO                    | Possible source of defensive programming error: <ul style="list-style-type: none"> <li>• pSingleTmStatus = NULL</li> <li>• STL internal data corrupted</li> </ul> | Not relevant            | Value must not be used | No state change |

**7.2.5**
**Artificial-failing APIs**
**7.2.5.1**
**STL\_SCH\_StartArtifFailing**

**Description:** sets artificial-failing configuration and starts artificial-failing feature.

**Declaration:** STL\_Status\_t STL\_SCH\_StartArtifFailing(const STL\_ArtifFailingConfig\_t \*pArtifFailingConfig)

**Table 30. STL\_SCH\_StartArtifFailing input information**

| Allowed states   | Parameters           |                 |
|--|----------------------|-----------------|
|  | Value                | Comments        |
| CPU TMx: <ul style="list-style-type: none"> <li>• CPU_TMx_CONFIGURED</li> </ul> Flash TM: <ul style="list-style-type: none"> <li>• FLASH_IDLE</li> <li>• FLASH_INIT</li> <li>• FLASH_CONFIGURED</li> </ul> RAM TM <ul style="list-style-type: none"> <li>• RAM_IDLE</li> <li>• RAM_INIT</li> <li>• RAM_CONFIGURED</li> </ul> | *pArtifFailingConfig | No state change |

**Table 31. STL\_SCH\_StartArtifFailing output information**

| STL_Status_t return value | Comments  | Output              | Comments        |
|---------------------------|---|---------------------|-----------------|
| STL_OK                    | Function successfully executed  | No output parameter | No state change |
| STL_KO                    | Possible source of defensive programming error: <ul style="list-style-type: none"> <li>• pArtifFailingConfig = NULL</li> <li>• configured values are not set for each test module</li> <li>• STL internal data corrupted</li> </ul> |                     |                 |

Additional information: All the following API calls are executed normally except if the STL\_Status\_t return value is set to STL\_OK, the test module status (\*pSingleTmStatus, \*pTmListStatus) is forced to a configured value.

**7.2.5.2**
**STL\_SCH\_StopArtifFailing**

Description: stops the artificial-failing feature.

Declaration: STL\_Status\_t STL\_SCH\_StopArtifFailing(void)

**Table 32. STL\_SCH\_StopArtifFailing input information**

| Allowed states   | Parameters         |                 |
|--|--------------------|-----------------|
|  | Value              | Comments        |
| CPU TMx: <ul style="list-style-type: none"> <li>• CPU_TMx_CONFIGURED</li> </ul> Flash TM: <ul style="list-style-type: none"> <li>• FLASH_IDLE</li> <li>• FLASH_INIT</li> <li>• FLASH_CONFIGURED</li> </ul> RAM TM <ul style="list-style-type: none"> <li>• RAM_IDLE</li> <li>• RAM_INIT</li> <li>• RAM_CONFIGURED</li> </ul> | No input parameter | No state change |

**Table 33. STL\_SCH\_StopArtifFailing output information**

| STL_Status_t return value | Comments  | Output              | Comments        |
|---------------------------|---|---------------------|-----------------|
| STL_OK                    | Function successfully executed  | No output parameter | No state change |
| STL_KO                    | Possible source of defensive programming error: <ul style="list-style-type: none"> <li>• STL internal data corrupted</li> </ul> |                     |                 |

**7.3**
**State machines**

Each CPU test module has its own state machine diagram linked to the CPU test APIs.

CPU test APIs

Figure 11. State machine diagram - CPU test APIs

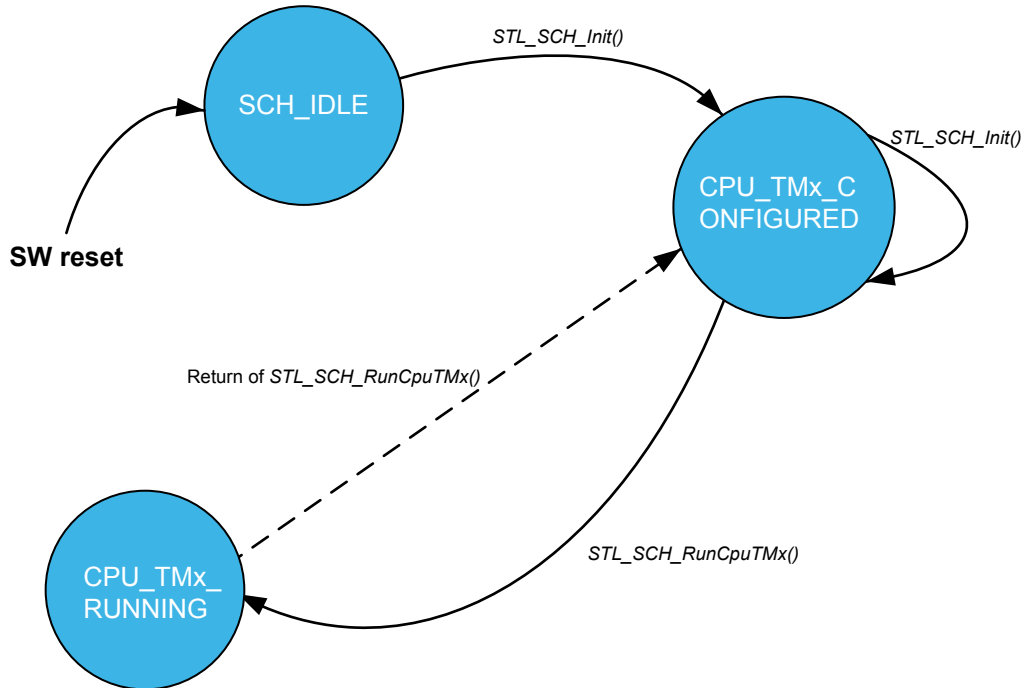

DT69947V1

Flash memory test APIs

Figure 12. State machine diagram - flash memory test APIs

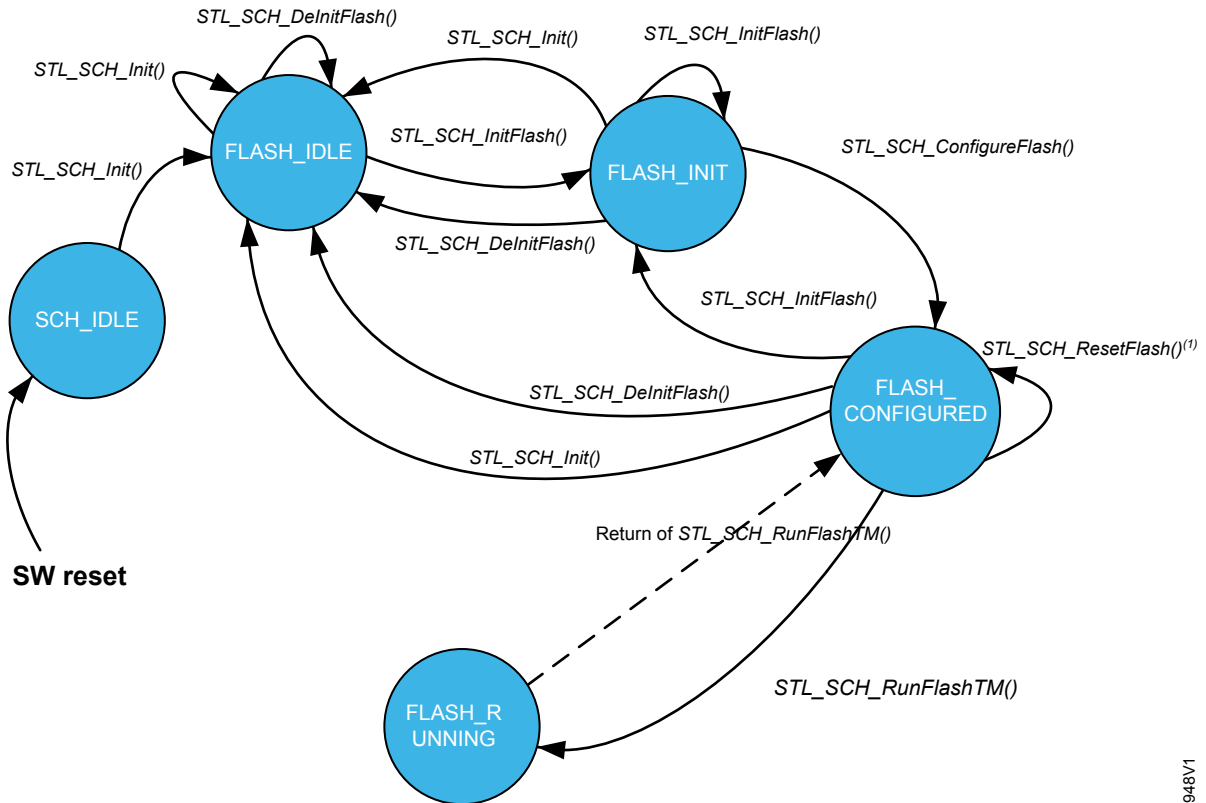

Note (1): Once all subsets are tested, the user needs to reset the flash memory test module to perform the test again.

DT69948V1

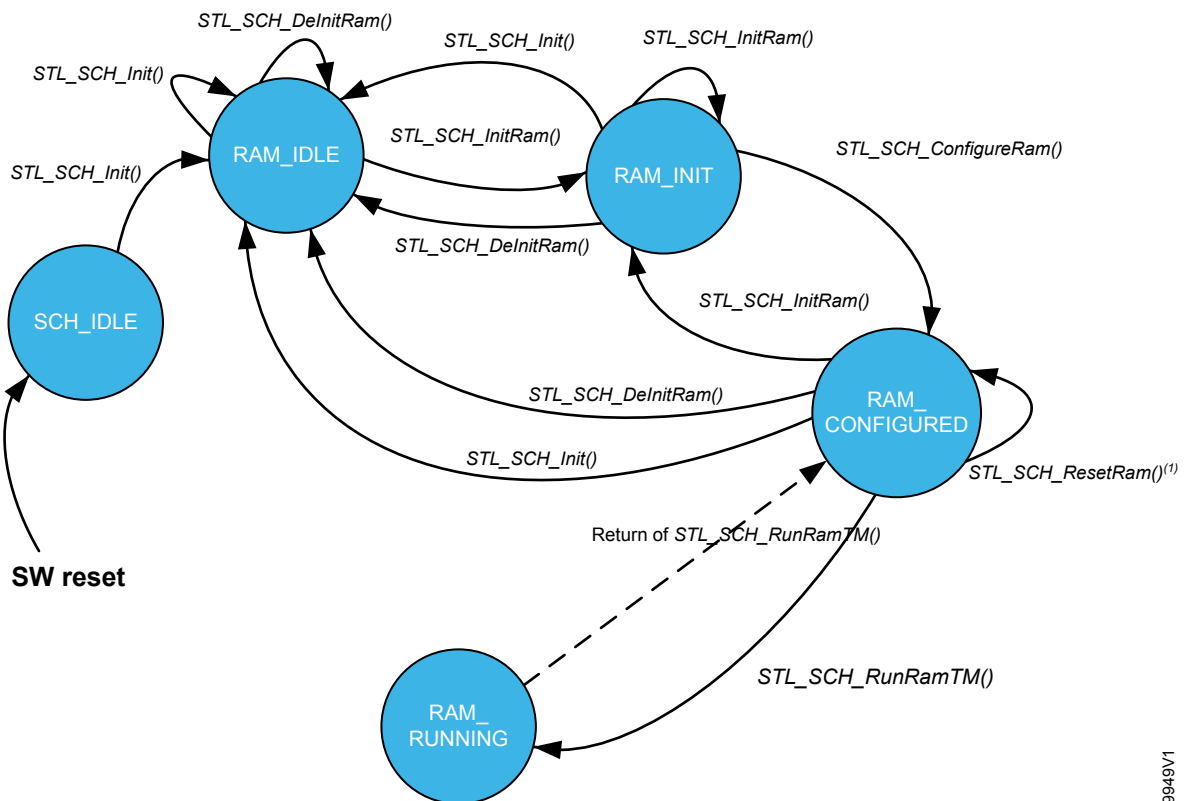
**RAM test APIs**
**Figure 13. State machine diagram - RAM test APIs**

Note (1): Once all subsets are tested, the user needs to reset the RAM test module to perform the test again.

DT60949V1

## 7.4 API usage and sequencing

The user application must:

- Maintain the availability and integrity of pointers passed as parameters during the tests. The STL does not copy the pointer content, and accesses directly the memory addresses defined by the application.
- Check the status of function return value (`STL_Status_t`), before checking the test result (`STL_TmStatus_t` or `STL_TmListStatus_t`). See the example in the delivered applications.

The APIs run independently of each other and therefore can be called in any order.

Only APIs dedicated to the configuration and initialization of the memories tests must be called before any execution of these tests is applied. See Section 7.3: State machines for more details.

The test flow is simplified, all the tests are now executed from C-code. All the modules are common and suitable for both startup and runtime testing. Differentiation between startup and runtime tests can be performed by proper sequencing and configuration of test modules. After application reset, common practice is to perform a full initial sequence including the complete set of tests executed over all the memory areas before the application starts. This sequence is defined in following order:

1. All the CPU tests
2. Complete tests of nonvolatile memory integrity
3. Functional test overall for the available space of volatile memories including the area especially dedicated to the stack

*Note:* Temporarily suppressing of the memory content backup can be applied to speed up initial testing of huge RAM areas where user does not need to preserve the memory content during this test. For more details see Section 4.3.7: RAM backup buffer. Functional test is not executed over areas containing program code and data when the code is executed from RAM.

4. Specific customer tests

Later, at runtime, the order of the tests can be changed and executed in more relaxed way. The memory regions under tests can be reduced. The test process can even be dynamically modified with prior focus on those areas where the most recently executed safety related code and data are stored. This is especially the case when considering factors like:

- Available application process safety time
- System overall performance
- Concrete status of the application

## 7.5 User parameters

In addition to parameters set directly inside the *APIs*, there are few parameters to be customized in the `stl_user_param_template.c` file. They are located in the code, with the following comments:

```
/* customisable */
```

Extract from `stl_user_param_template.c`:

```
/* Flash configuration */
#define STL_ROM_START (0x08000000U) /* customizable */
#define STL_ROM_END (0x0801FFFFU) /* customizable */
```

The customization depends upon the STM32 product and the user choice.

```
/* TM RAM Backup Buffer configuration */
....
/* User shall locate the buffer in RAM */
/* The RAM backup buffer is placed in "backup_buffer_section". */
/* "backup_buffer_section" section is defined in scatter file */
```

The customizing depends on the user choice.

The remaining user parameters are defined by flags, and can be checked in the following files:

- `stl_user_param_template.c`: use of RAM backup buffer or not
- `stl_util.c`: use of software or hardware *CRC* computation
- `stl_stm32_hw_config.h`: if *CRC* hardware is used, choose the right *CRC* IP configuration according to the STM32 device

Refer to [Section 5.5.2: Steps to build an application from scratch](#) for the flag configuration check.



## 8 Test examples

Figure 14 shows an example of a possible sequence of STL API calls through the STL scheduler and returned information provided by STL (refer to Figure 1 and Table 2).

Figure 14. Test flow example

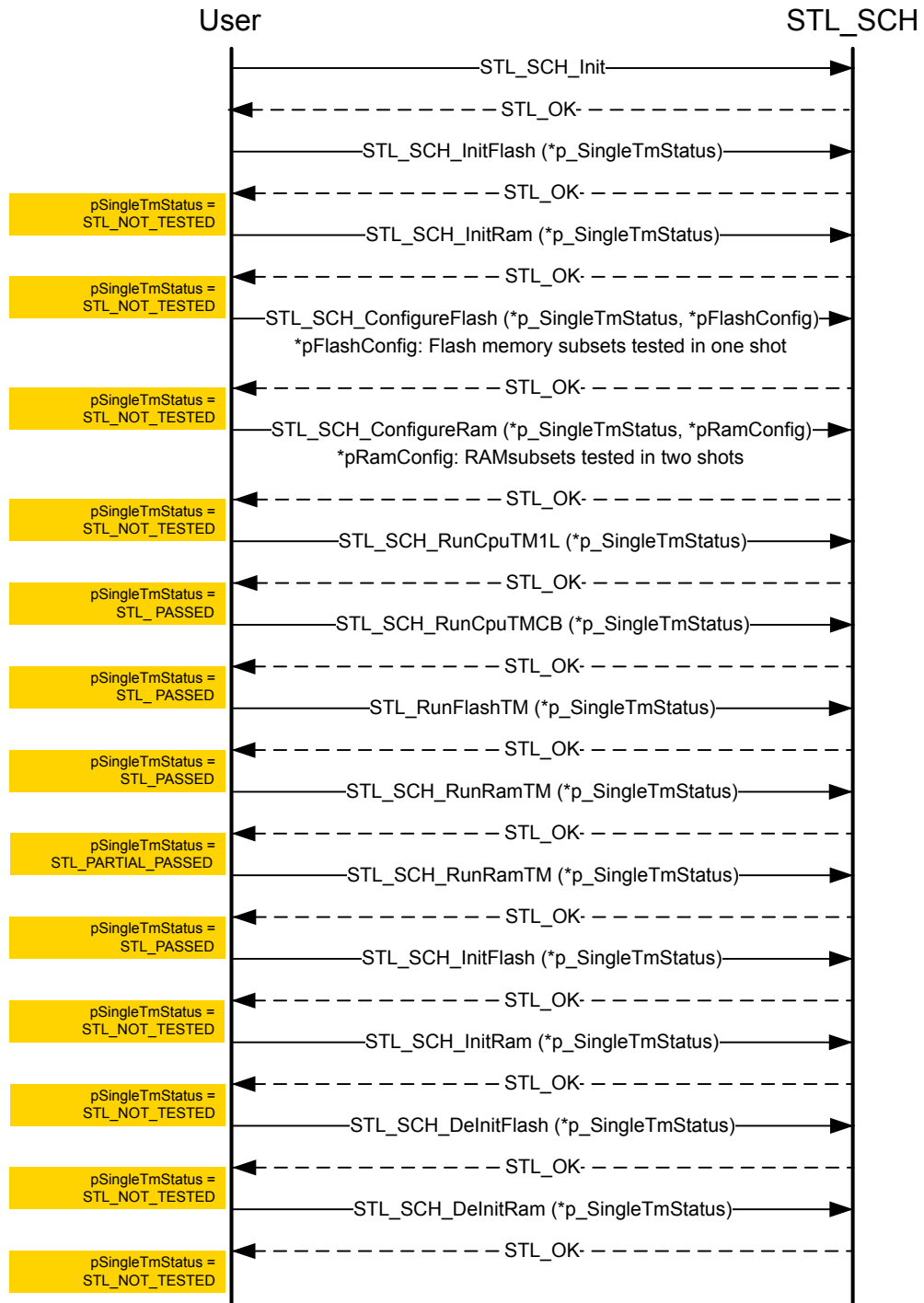

Legend:  
 Test status

DT70600V1

Figure 15 shows a detailed example of flash memory test flow handling:

- Use of two flash memory subsets
- Use of functions
  - STL\_SCH\_RunFlashTM → only the flash memory test module is executed
  - STL\_SCH\_ResetFlash
- Function return value
- Flash memory test module result value: `pSingleTmStatus` → in this case, it contains the result of the flash memory test

Figure 16 shows a detailed example of RAM test flow handling:

- Use of two RAM subsets
- Use of functions:
  - STL\_SCH\_RunRAMTM → only the RAM test module is executed
  - STL\_SCH\_ResetRam
- Function return value
- RAM test module result value: `pSingleTmStatus` → in this case, it contains the result of the RAM memory test

Figure 15. Flash memory test flow example

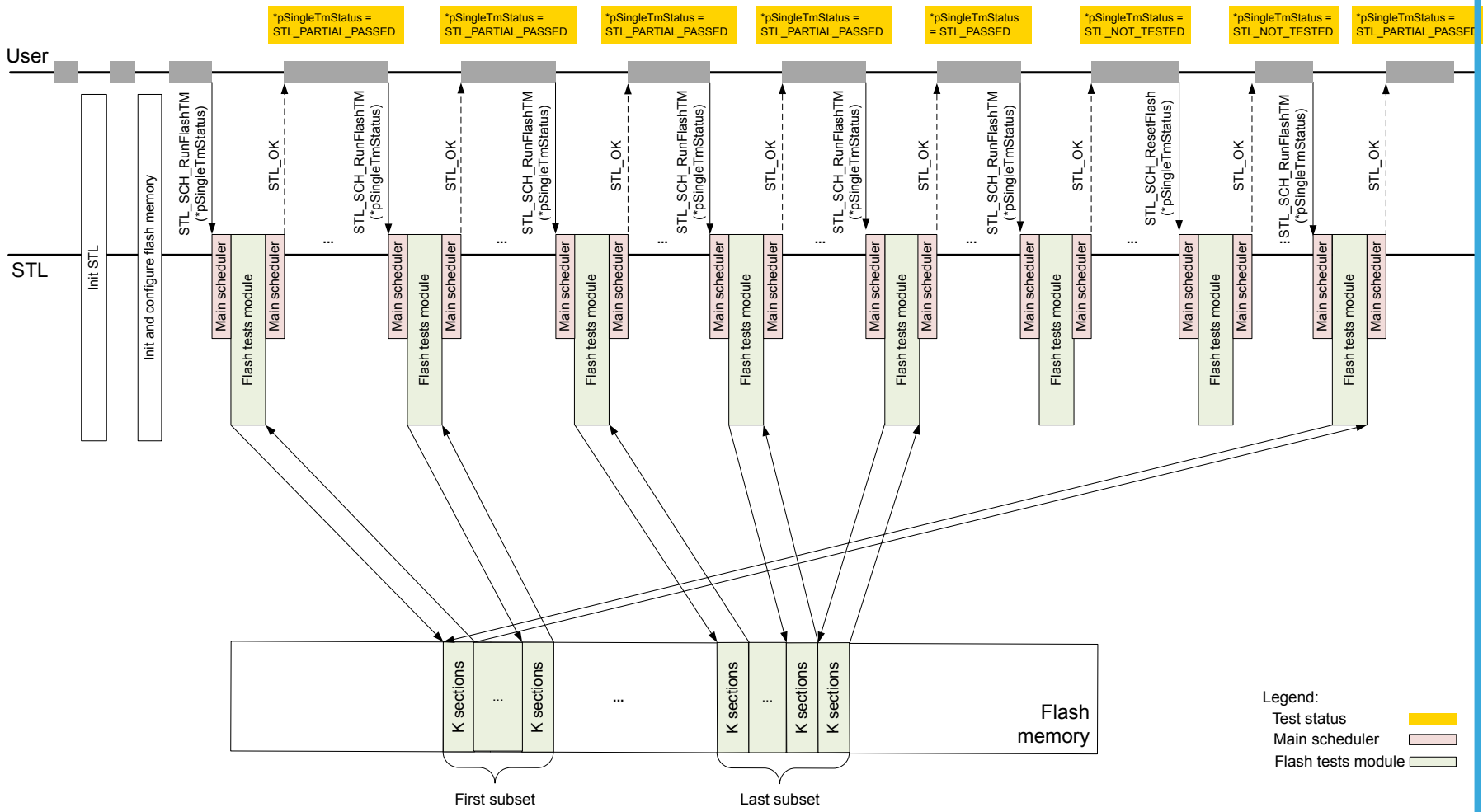
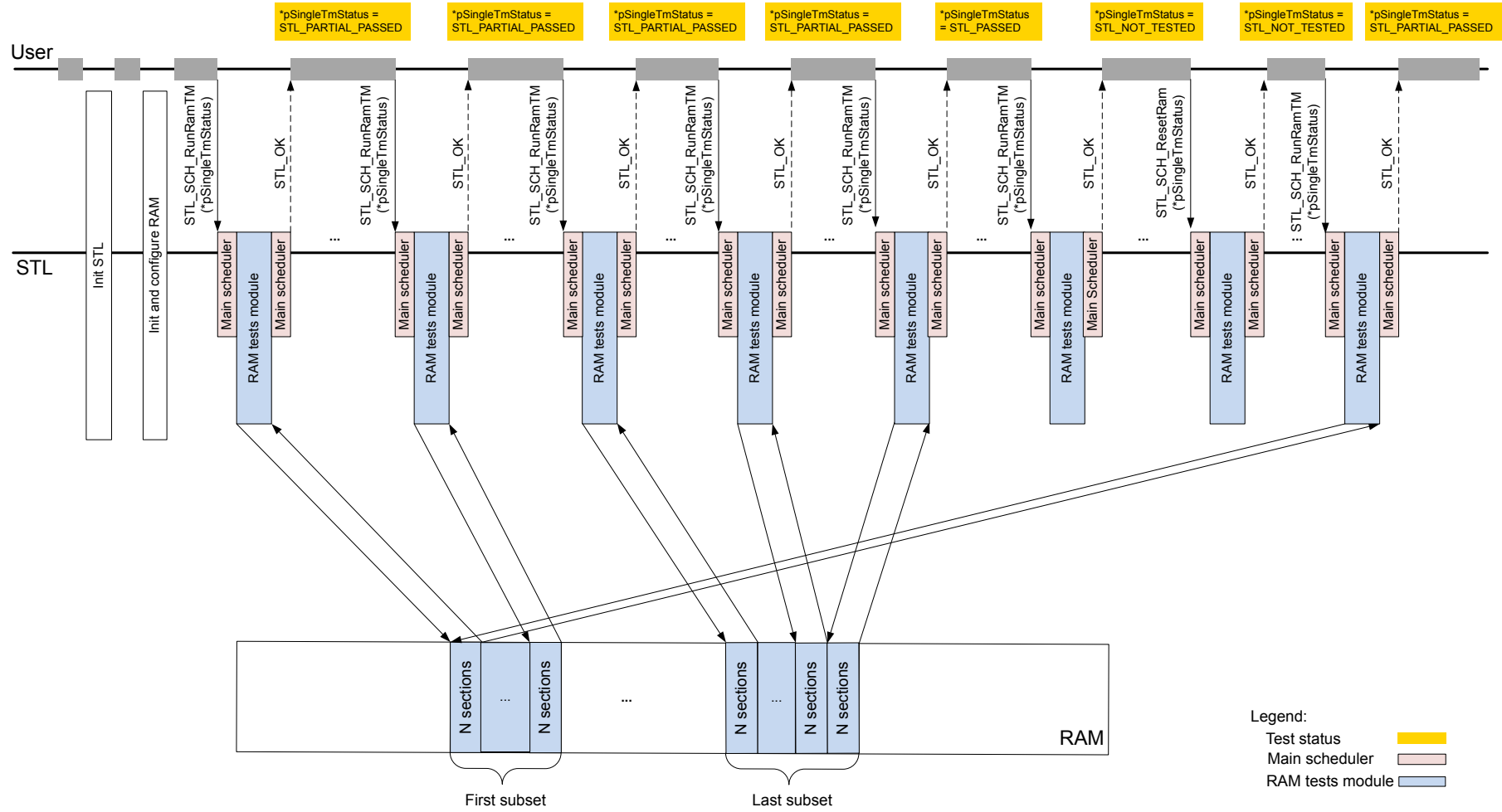

Figure 16. RAM test flow example



## 9 STL: execution timing details

The data in the following table is obtained with the test set-up described in [Section 4.2: STL performance data](#)

**Table 34. Integration tests**

| Test                               | Duration (in $\mu$ s) |                     | Tested memory      |
|------------------------------------|-----------------------|---------------------|--------------------|
|                                    | Hardware CRC          | Software CRC        |                    |
| STL_SCH_InitFlash()                | 10                    | 10                  | -                  |
| STL_SCH_ConfigureFlash()           | 15                    | 15                  | -                  |
| STL_SCH_RunFlashTM()               | 972                   | 5416 <sup>(1)</sup> | 17408 bytes tested |
| STL_SCH_InitRam()                  | 10                    | 10                  | -                  |
| STL_SCH_ConfigureRam()             | 15                    | 15                  | -                  |
| STL_SCH_RunRamTM() <sup>(2)</sup>  | 8203                  | 8203                | 8160 bytes tested  |
| STL_SCH_RunCpuTM1L()               | 74                    | 74                  | -                  |
| STL_SCH_RunCpuTM7() <sup>(2)</sup> | 32                    | 32                  | -                  |
| STL_SCH_RunCpuTMCB()               | 11                    | 11                  | -                  |

1. Test duration increased because of the CRC algorithm (see [Section 4.1.1: Scheduler principle](#)).
2. Default configuration: `STL_ENABLE_IT` and `STL_DISABLE_RAM_BCKUP_BUF` are not enabled.

## 10 Application-specific tests not included in ST firmware self-test library

The user must focus on all the remaining required tests covering application specific *MCU* parts not included in the ST firmware library:

- Test of analog parts (ADC/DAC, multiplexer)
- Test of digital I/O
- External addressing
- External communication
- Timing and interrupts
- System clock frequency measurement.

*Note:* *The clock frequency measurement is not an integrated part of the STL package. The clock testing module is provided as full source format within STL integration example to demonstrate the capability of implementing additional user defined testing modules which can be included at the STL flow. For more details refer to Section 10.5: Extension capabilities STL library.*

A valid solution for these components is strongly dependent on application and device-peripheral capability. The application must follow as precisely as possible the suggested testing principles from the very early stages of its design.

Very often this method leads to redundancy at both hardware and software levels.

Hardware methods can be based on:

- Multiplication of inputs and/or outputs
- Reference point measurement
- Loop-back read control at analog or digital outputs such as *DAC*, *PWM*, *GPIO*
- Configuration protection.

Software methods can be based on:

- Repetition in time, multiple acquisitions, multiple checks, decisions, or calculations made at different times or performed by different methods
- Data redundancy (data copies, parity check, error correction/detection codes, checksum, protocol)
- Plausibility check (valid range, valid combination, expected change, or trend)
- Periodicity and occurrence checks (flow and occurrence in time controls)
- Periodic checks of correct configuration (for example, read back the configuration registers).

### 10.1 Analog signals

Measured values must be checked for consistency and verified by measurements performed on other redundant channels. Free channels can be used for reading some reference voltages with testing of analog multiplexers used in the application. The internal reference voltage must also be checked.

Some STM32 microcontroller devices feature two (or even three) independent *ADC* blocks. To ensure the reliability of the results, perform several conversions on the same channel using two different *ADC* blocks for security reasons. The results can be obtained using either:

- Multiple acquisitions from one channel
- Compare redundant channels followed by an averaging operation.

Here are some tips for testing the functionality of analog parts at STM32 microcontroller devices.

### ADC input pin disconnection

The ADC input pin disconnection can be tested by applying additional signal source on the tested pin.

- Some STM32 microcontroller devices feature internal pull-down or pull-up resistor activation facilities on the analog input. They can also feature a free pin with *DAC* functionality or a digital *GPIO* output. Any one of these pins can be used as a known reference input to the ADC.
- Some STM32 microcontroller devices feature a routing interface. This interface can be used for internal connection between pins to make:
  - testing loop-back
  - additional signal injection
  - duplicate measurement at some other independent channel.

*Note:* The user must prevent any critical voltage injection into an analog pin. This can happen when digital and analog signals are combined and different power levels are applied to analog and digital parts ( $V_{DD} > V_{DDA}$ ).

### Internal reference voltage and temperature sensor ( $V_{BAT}$ for some devices)

- Ratio between these signals can be verified within the allowed ranges.
- Additional testing can be performed where the  $V_{DD}$  voltage is known.

### ADC clock

Measurement of the *ADC* conversion time (by timers) can be used to test the independent *ADC* clock functionality.

### DAC output functionality

Free *ADC* channels can be used to check if the *DAC* output channel is working correctly.

The routing interface can be used when connecting the *ADC* input channel and the *DAC* output channel.

### Comparator functionality

Comparison between known voltage and *DAC* output or internal reference voltage can be used for testing comparator output on another comparator input.

Analog signal disconnection can be tested by pull-down or pull-up activation on a tested pin and comparing this signal with the *DAC* voltage as reference on another comparator input.

### Operational amplifier

Functionality can be tested forcing (or measuring) a known analog signal to the operational amplifier (*OPAMP*) input pin, and internally measuring the output voltage with the *ADC*. The input signal to the *OPAMP* can be also measured by *ADC* (on another channel).

## 10.2 Digital I/Os

Class B tests must detect any malfunction on digital I/Os, too. It could be covered by plausibility checks together with some other application parts. For example, change of an analog signal from the temperature sensor must be checked when heating/cooling digital control is switched on/off. Selected port bits can be locked by applying the correct lock sequence to the lock bit in the `GPIOx_LCKR` register. This action prevents unexpected changes to the port configuration. Reconfiguration is only possible at the next reset sequence in this case. In addition, the bit banding feature can be used for atomic manipulation of the SRAM and peripheral registers.

## 10.3 Interrupts

Occurrence in time and periodicity of events must be checked. Different methods can be used; one of them uses a set of incremental counters where every interrupt event increments a specific counter. The values in the counters are then cross-checked periodically with other independent time bases. The number of events occurred within the last period depends upon the application requirements.

The configuration lock feature can be used to secure the timer register settings with three levels controlled by the `TIMx_BDTR` register. Unused interrupt vectors must be diverted into a common error handler. Polling is preferable for non-safety relevant tasks if possible to simplify an application interrupt scheme.

## 10.4 Communication

Data exchange during communication sessions must be checked while including redundant information in the data packets. Parity, sync signals, CRC check sums, block repetition, or protocol numbering can be used for this purpose. Robust application software protocol stacks like TCP/IP give higher level of protection, if necessary. Periodicity and occurrence in time of the communication events together with protocol error signals has to be checked permanently.

The user can find more information and methods in product-dedicated safety manuals.

## 10.5 Extension capabilities STL library

This framework version features a significantly easier and more flexible implementation than the previous versions of this *STL* library (see [Section 1.2: Reference documents](#)) which allows for an easier extension. Even with the new applied format, the framework keeps the same set of self-testing methods to comply with the IEC 60730 standard which are already implemented by previous versions of the library:

- Test of registers at *CPU TMs*
- 32-bit CRC calculation compatible with STM32 HW CRC unit at Flash *TM*
- March C test respecting physical address order of the RAM *TM*
- Timer triggered by LSI to check system clock frequency of the clock *TM* defined at *STL* integration example

The main improvements of the new framework version are:

- Module oriented
- Supports partial testing
- Based on configuration and parametrizing structures
- No differentiation between startup and runtime test modules
- CRC calculation support based on a format provided by the STM32CubeProgrammer command-line feature
- Pre-compiled and fixed object code format of key generic modules
- No dependency of the generic modules execution on drivers or compilers
- Error handling includes reporting of defensive programming results
- Artificial failure control feature to verify the proper integration of the modules with no need for additional instrumentation code
- Easy extension by additional application specific modules.

An example of an additional specific test module implementation is available in the firmware package integration example. A specific test module based on the cross check measurement method of two independent clock sources is delivered as open source format together with the firmware package integration example. This module must be adapted by the end user to take into account specific dependencies on the configuration of the applied clock system.

This module uses the same measurement principle already applied in previous versions of the library. The hardware used for the frequency comparison must initially be configured (Channel 1 of TIM16 triggered by LSI) to invoke clock measurement before the associated *API* is called. This hardware configuration is done at the end of `STL_Init()` procedure in the `main.c` file. The *API* is written to use interface compatibility with the regular *APIs* integrated in the *STL* so the same format is applied in its declaration:

```
STL_Status_t STL_SCH_RunClockTest(STL_TmStatus_t *pSingleTmStatus)
```

The parameter that is passed during this function call acts as a pointer to the clock module measurement status, and the function itself provides a `STL_KO` vs `STL_OK` return status as well as do the regular *STL* modules if defensive programming fails. If the clock measurement hardware is active and the new period value updated by the last measurement cycle (set to 8 consecutive LSI periods) is found at the expected interval (defined by macros `CLK_LimitLow` and `CLK_LimitHigh`), the module measurement status value is changed into `STL_PASSED`. If not it is set to `STL_FAILED` as per the regular *API* modules. This is also the case when artificial failing of the module is invoked.

In a similar way, the user can integrate the following modules. For example, any stack hardening techniques like stack boundary area check or implementing watchdog testing and servicing is no longer included at this new package by default. The source code of these tests is available in older versions of this library see [2]. Refer to [1] for additional information about the commonly recognized safety methods that are not specifically required by the household standard. They may be useful to improve the user application robustness.



## 11 Compliance with IEC, UL, and CSA standards

The pivotal IEC standards are IEC 60730-1 and IEC 60335-1, harmonized with UL/CSA 60730-1 and UL/CSA 60335-1 starting from the 4th edition. Previous UL/CSA editions use references to the UL1998 standard in addition.

The standards are updated at regular intervals. The range of all the regulations collected in the standards is very large; the sections that concern the requirements for software self-tests of generic parts of microcontrollers is very specific. In most cases, the provided updates do not impact these specific parts of the standard at all. Therefore, an obsolete certification can still comply and stay valid for newer editions of the standard.

The relevant detailed conditions required are defined in:

- Annexes Q and R of the IEC 60335-1 norm
- Annex H of the IEC 60730-1 norm.

Three classes are defined by the IEC 60730-1:2010 H.2.22 they are:

- Class A: control functions that are not intended to be relied upon for the safety of the application.
- Class B: control functions that are intended to prevent an unsafe state of the controlled equipment. Failure of the control function does not directly lead to a hazardous situation.
- Class C: control functions that are intended to prevent special hazards such as explosion or which failure could directly cause a hazard in the appliance.

For a programmable electronic component applying a safety protection function, the IEC 60335-1 standard requires incorporation of software measures to control fault and error conditions specified in tables R.1 and R.2:

- Table R.1 summarizes general conditions comparable with requirements given for Class B level
- Table R.2 summarizes specific conditions comparable with requirements given for Class C level.

Requirements for Class B level software, which is the subject of this user manual, are defined to prevent hazards if another fault occurs elsewhere in the appliance. In this case, the self-test software is run on the appliance after a failure. An accidental software fault occurring during a safety-critical routine execution does not necessarily result in a hazard due to another applied redundant software procedure or hardware protection function required at this level.

There is no such hardware protection required in Class C level counting that whatever fault at safety-critical software can result in a potential hazard. To comply with this level, more robust testing is required than the one usually applicable to standard industrial microcontrollers like the STM32. An acceptable solution usually leads to the implementation of specific hardware redundancy at system level, like dual channel structures.

For more information on more stringent test methods, refer to the industrial documentation [1].

IEC 60730-1 defines the set of applicable architectures acceptable for the design of Class B control functions:

- Single channel with functional test. A single CPU executes the software control functions as required. A functional test is performed as the software starts. It guarantees that all critical features work properly.
- Single channel with periodic self-test. A single CPU executes the software control functions. Embedded periodic tests check the various critical functions of the system without impacting the performance of the planned control tasks.
- Dual channel (homogeneous or diverse) with comparison. The software is designed to execute control functions (identically or differently) on two independent CPUs. Both CPUs compare internal signals for fault detection when executing any safety-critical task.

*Note: This structure is recognized to comply with Class C level also. A common principle is that whatever method complies with Class C automatically complies with Class B.*

An overview of the methods applied by STL and their references to the standards are listed on the table below. The STL is focused on generic components of the microcontroller reused at all applications. The test of the other parts is under the end-user responsibility as their testing is mostly application specific and can be achieved effectively at the planning stage of the system design. Refer to [Section 10: Application-specific tests not included in ST firmware self-test library](#) for more information on how to handle these application-specific tests.

**Table 35. IEC 60335-1 components covered by the X-CUBE-CLASSB library by methods recognized by IEC-60730-1**

| Component of Table R.1 (IEC 60335-1: Annex R) |  | Class B | References to IEC 60730-1: Annex H)    | Fault/error                             | Safety method applied at X-CUBE-CLASSB   | Note   |
|---|--|---------|--|---|--|--|
| 1. CPU  | 1.1 CPU registers  | X       | H.2.16.5<br>H.2.16.6<br>H.2.19.6       | Stuck at                                | Periodic run of the STL TM1L, TM7, and TMCB CPU test modules   | Combination of functional and pattern tests of the CPU registers,(general-purpose R0-R12, special-purpose main and process stack pointers R13, program status APSR and CONTROL registers) <sup>(1)</sup> |
|   | 1.2 Instruction decoding and execution                       |         |  | N/A                                     |  | Not required for Class B   |
|   | 1.3 Program counter  | X       | H.2.18.10.2<br>H.2.18.10.4             | Stuck at                                | N/A<br>End-user responsibility   | Logical and time slot program sequence monitoring, implementation of watchdogs   |
|   | 1.4 Addressing   |         |  | N/A                                     |  | Not required for Class B   |
|   | 1.5 Data path instruction decoding                           |         |  | N/A                                     |  | Not required for Class B   |
| 2. Interrupt handling and execution           |  | X       | H.2.18.10.4<br>H.2.18.18               | No interrupt or too frequent interrupts | Handshake of results is applied at the interrupt associated with a clock cross-check measurement module                                      | End-user responsibility for the other interrupts implemented at application  |
| 3. Clock                                      |  | X       | H.2.18.10.1<br>H.2.18.10.4             | Wrong frequency                         | Periodic run of clock cross-check module. Added at open source format as a user specific test module within the firmware integration example | Clock cross-check measurement done between two independent clock sources (system clock and LSI)  |
| 4. Memory                                     | 4.1 Invariable memory  | X       | H.2.19.3.1<br>H.2.19.3.2<br>H.2.19.8.2 | All single bit faults                   | Periodic execution of the STL FlashTM test module  | ECC enable under end-user responsibility <sup>(2)</sup>  |
|   | 4.2. Variable memory   | X       | H.2.19.6<br>H.2.19.8.2                 | DC fault                                | Periodic execution of the STL RamTM test module  | ECC or parity enable under end-user responsibility <sup>(2)</sup>  |
|   | 4.3 Addressing (relevant for variable and invariable memory) | X       | H.2.19.8.2                             | Stuck at                                | -  | Tested indirectly by execution of the applied memory test modules  |
| 5. Internal data path                         | 5.1 Data   | X       | H.2.19.8.2                             | Stuck at                                | -  | ECC enable under end-user responsibility <sup>(2)</sup>  |
|   | 5.2 Addressing   | X       | H.2.19.8.2                             | Wrong address                           | -  |  |
| 6. External communication                     |  | X       | -                                      | -                                       | N/A<br>End-user responsibility   | -  |
| 7. I/O periphery                              |  | X       | -                                      | -                                       | N/A<br>End-user responsibility   | -  |
| 8. Monitoring devices and comparators         |  |         |  | N/A                                     |  | Not required for Class B   |
| 9. Custom chips                               |  | X       | -                                      | -                                       | N/A  | -  |

1. CPU registers R14 (LR) and R15 (PC) are tested indirectly via defensive programming methods.

2. For availability and functionality of concrete embedded hardware safety feature, refer to the product user and safety manual.

## Revision history

**Table 36. Document revision history**

| Date        | Version | Changes          |
|-------------|---------|------------------|
| 04-Feb-2025 | 1       | Initial release. |

## Glossary

**ADC** analog to digital converter

**AEABI** Arm® embedded application binary interface

**API** application programming interface

**APSR** CPU status register

**BSP** board support package

### Class B

middle level of regulations targeting safety for home appliances (UL/CSA/IEC 60730-1/60335-1)

**CMSIS** common microcontroller software interface standard

**CPU** central processing unit

**CRC** cyclic redundancy check

**DAC** digital to analog converter

**FPU** floating-point unit

**GPIO** general purpose input output

**HAL** hardware abstraction level

**ICache** instruction cache

**IDE** integrated development environment

**LL** low layer

**MCU** microcontroller unit

**MPU** memory protection unit

**MSP** main stack pointer

**OPAMP** operational amplifier

**PSP** process stack pointer

**PWM** pulse width modulation

**RAM** random access memory

**SDK** software development kit

**STL** self-test library

**TM** test module

## Contents

|          |  |           |
|----------|--|-----------|
| <b>1</b> | <b>General information</b>                   | <b>2</b>  |
| 1.1      | Purpose and scope                            | 2         |
| 1.2      | Reference documents                          | 2         |
| <b>2</b> | <b>STM32Cube overview</b>                    | <b>3</b>  |
| 2.1      | What is STM32Cube?                           | 3         |
| 2.2      | How does this software complement STM32Cube? | 3         |
| <b>3</b> | <b>STL overview</b>                          | <b>4</b>  |
| 3.1      | Architecture overview                        | 4         |
| 3.2      | Supported products                           | 5         |
| <b>4</b> | <b>STL description</b>                       | <b>6</b>  |
| 4.1      | STL functional description                   | 6         |
| 4.1.1    | Scheduler principle                          | 6         |
| 4.1.2    | CPU Arm® core tests                          | 7         |
| 4.1.3    | Flash memory tests                           | 8         |
| 4.1.4    | RAM tests                                    | 10        |
| 4.2      | STL performance data                         | 12        |
| 4.2.1    | STL execution timings                        | 12        |
| 4.2.2    | STL code and data size                       | 13        |
| 4.2.3    | STL stack usage                              | 13        |
| 4.2.4    | STL heap usage                               | 13        |
| 4.2.5    | STL interrupt masking time                   | 13        |
| 4.3      | STL user constraints                         | 14        |
| 4.3.1    | Privileged-level                             | 14        |
| 4.3.2    | RCC resources                                | 14        |
| 4.3.3    | CRC resources                                | 14        |
| 4.3.4    | Interrupt management                         | 14        |
| 4.3.5    | DMA  | 15        |
| 4.3.6    | Supported memories                           | 15        |
| 4.3.7    | RAM backup buffer                            | 15        |
| 4.3.8    | Memory mapping                               | 16        |
| 4.3.9    | Processor mode                               | 16        |
| 4.4      | End-user integration tests                   | 16        |
| 4.4.1    | Test 1: correct STL execution                | 16        |
| 4.4.2    | Test 2: correct STL error-message processing | 16        |
| <b>5</b> | <b>Package description</b>                   | <b>17</b> |

|           |   |           |
|-----------|---|-----------|
| 5.1       | General description   | 17        |
| 5.2       | Architecture  | 17        |
| 5.2.1     | STM32Cube HAL   | 17        |
| 5.2.2     | Board support package (BSP)   | 18        |
| 5.2.3     | STL   | 18        |
| 5.2.4     | User application example  | 18        |
| 5.2.5     | STL integrity   | 18        |
| 5.3       | Folder structure  | 19        |
| 5.4       | APIs  | 19        |
| 5.4.1     | Compliance  | 19        |
| 5.4.2     | Dependency  | 20        |
| 5.4.3     | Details   | 20        |
| 5.5       | Application: compilation process  | 20        |
| 5.5.1     | Steps to build a delivered STL example  | 20        |
| 5.5.2     | Steps to build an application from scratch                                      | 21        |
| <b>6</b>  | <b>Hardware and software environment setup</b>                                  | <b>23</b> |
| 6.1       | Hardware setup  | 23        |
| 6.2       | Software setup  | 23        |
| 6.2.1     | Development tool-chains and compilers   | 23        |
| 6.2.2     | CRC tool set-up   | 24        |
| <b>7</b>  | <b>STL: User APIs and state machines</b>  | <b>25</b> |
| 7.1       | User structures   | 25        |
| 7.2       | User APIs   | 26        |
| 7.2.1     | Common API  | 26        |
| 7.2.2     | CPU Arm® core testing APIs  | 26        |
| 7.2.3     | Flash memory testing APIs   | 27        |
| 7.2.4     | RAM testing APIs  | 31        |
| 7.2.5     | Artificial-failing APIs   | 35        |
| 7.3       | State machines  | 36        |
| 7.4       | API usage and sequencing  | 39        |
| 7.5       | User parameters   | 40        |
| <b>8</b>  | <b>Test examples</b>  | <b>41</b> |
| <b>9</b>  | <b>STL: execution timing details</b>  | <b>45</b> |
| <b>10</b> | <b>Application-specific tests not included in ST firmware self-test library</b> | <b>46</b> |
| 10.1      | Analog signals  | 46        |
| 10.2      | Digital I/Os  | 47        |

---

|           |   |           |
|-----------|---|-----------|
| 10.3      | Interrupts .....  | 47        |
| 10.4      | Communication .....                                     | 48        |
| 10.5      | Extension capabilities STL library .....                | 48        |
| <b>11</b> | <b>Compliance with IEC, UL, and CSA standards .....</b> | <b>49</b> |
|           | Revision history .....                                  | 51        |
|           | Glossary .....  | 52        |
|           | List of tables .....                                    | 56        |
|           | List of figures .....                                   | 57        |

## List of tables

|                  |  |    |
|------------------|--|----|
| <b>Table 1.</b>  | Applicable product . . . . .   | 1  |
| <b>Table 2.</b>  | STL return information . . . . .   | 7  |
| <b>Table 3.</b>  | STL execution timings, clock at 48 MHz . . . . .   | 13 |
| <b>Table 4.</b>  | STL code size and data size (in bytes) . . . . .   | 13 |
| <b>Table 5.</b>  | STL maximum interrupt masking information . . . . .  | 14 |
| <b>Table 6.</b>  | STL_SCH_Init input information . . . . .   | 26 |
| <b>Table 7.</b>  | STL_SCH_Init output information . . . . .  | 26 |
| <b>Table 8.</b>  | STL_SCH_RunCpuTMx input information . . . . .  | 27 |
| <b>Table 9.</b>  | STL_SCH_RunCpuTMx output information . . . . .   | 27 |
| <b>Table 10.</b> | STL_SCH_InitFlash input information . . . . .  | 27 |
| <b>Table 11.</b> | STL_SCH_InitFlash output information . . . . .   | 27 |
| <b>Table 12.</b> | STL_SCH_ConfigureFlash input information . . . . .   | 28 |
| <b>Table 13.</b> | STL_SCH_ConfigureFlash output information . . . . .  | 29 |
| <b>Table 14.</b> | STL_SCH_RunFlashTM input information . . . . .   | 29 |
| <b>Table 15.</b> | STL_SCH_RunFlashTM output information . . . . .  | 30 |
| <b>Table 16.</b> | STL_SCH_ResetFlash input information . . . . .   | 30 |
| <b>Table 17.</b> | STL_SCH_ResetFlash output information . . . . .  | 30 |
| <b>Table 18.</b> | STL_SCH_DeInitFlash input information . . . . .  | 31 |
| <b>Table 19.</b> | STL_SCH_DeInitFlash output information . . . . .   | 31 |
| <b>Table 20.</b> | STL_SCH_InitRam input information . . . . .  | 31 |
| <b>Table 21.</b> | STL_SCH_InitRam output information . . . . .   | 31 |
| <b>Table 22.</b> | STL_SCH_ConfigureRam input information . . . . .   | 32 |
| <b>Table 23.</b> | STL_SCH_ConfigureRam output information . . . . .  | 33 |
| <b>Table 24.</b> | STL_SCH_RunRamTM input information . . . . .   | 33 |
| <b>Table 25.</b> | STL_SCH_RunRamTM output information . . . . .  | 34 |
| <b>Table 26.</b> | STL_SCH_ResetRam input information . . . . .   | 34 |
| <b>Table 27.</b> | STL_SCH_ResetRam output information . . . . .  | 34 |
| <b>Table 28.</b> | STL_SCH_DeInitRam input information . . . . .  | 35 |
| <b>Table 29.</b> | STL_SCH_DeInitRam output information . . . . .   | 35 |
| <b>Table 30.</b> | STL_SCH_StartArtifFailing input information . . . . .  | 35 |
| <b>Table 31.</b> | STL_SCH_StartArtifFailing output information . . . . .   | 36 |
| <b>Table 32.</b> | STL_SCH_StopArtifFailing input information . . . . .   | 36 |
| <b>Table 33.</b> | STL_SCH_StopArtifFailing output information . . . . .  | 36 |
| <b>Table 34.</b> | Integration tests . . . . .  | 45 |
| <b>Table 35.</b> | IEC 60335-1 components covered by the X-CUBE-CLASSB library by methods recognized by IEC-60730-1 . . . . . | 50 |
| <b>Table 36.</b> | Document revision history . . . . .  | 51 |



## List of figures

|            |  |    |
|------------|--|----|
| Figure 1.  | STL architecture . . . . .                                     | 4  |
| Figure 2.  | Single test control call architecture . . . . .                | 7  |
| Figure 3.  | Flash memory test: CRC principle . . . . .                     | 9  |
| Figure 4.  | Flash memory test: CRC use cases versus program areas. . . . . | 10 |
| Figure 5.  | RAM test: usage . . . . .                                      | 12 |
| Figure 6.  | Software architecture overview . . . . .                       | 17 |
| Figure 7.  | Project file structure . . . . .                               | 19 |
| Figure 8.  | IAR™ post-build actions screenshot. . . . .                    | 22 |
| Figure 9.  | CRC tool command line . . . . .                                | 22 |
| Figure 10. | STM32 Nucleo board example . . . . .                           | 23 |
| Figure 11. | State machine diagram - CPU test APIs. . . . .                 | 37 |
| Figure 12. | State machine diagram - flash memory test APIs . . . . .       | 38 |
| Figure 13. | State machine diagram - RAM test APIs . . . . .                | 39 |
| Figure 14. | Test flow example . . . . .                                    | 41 |
| Figure 15. | Flash memory test flow example . . . . .                       | 43 |
| Figure 16. | RAM test flow example . . . . .                                | 44 |

**IMPORTANT NOTICE – READ CAREFULLY**

STMicroelectronics International NV and its affiliates (“ST”) reserve the right to make changes corrections, enhancements, modifications, and improvements to ST products and/or to this document any time without notice.

This document is provided solely for the purpose of obtaining general information relating to an ST product. Accordingly, you hereby agree to make use of this document solely for the purpose of obtaining general information relating to the ST product. You further acknowledge and agree that this document may not be used in or in connection with any legal or administrative proceeding in any court, arbitration, agency, commission or other tribunal or in connection with any action, cause of action, litigation, claim, allegation, demand or dispute of any kind. You further acknowledge and agree that this document shall not be construed as an admission, acknowledgment or evidence of any kind, including, without limitation, as to the liability, fault or responsibility whatsoever of ST or any of its affiliates, or as to the accuracy or validity of the information contained herein, or concerning any alleged product issue, failure, or defect. ST does not promise that this document is accurate or error free and specifically disclaims all warranties, express or implied, as to the accuracy of the information contained herein. Accordingly, you agree that in no event will ST or its affiliates be liable to you for any direct, indirect, consequential, exemplary, incidental, punitive, or other damages, including lost profits, arising from or relating to your reliance upon or use of this document.

Purchasers should obtain the latest relevant information on ST products before placing orders. ST products are sold pursuant to ST’s terms and conditions of sale in place at the time of order acknowledgment, including, without limitation, the warranty provisions thereunder.

In that respect, note that ST products are not designed for use in some specific applications or environments described in above mentioned terms and conditions.

Purchasers are solely responsible for the choice, selection, and use of ST products and ST assumes no liability for application assistance or the design of purchasers’ products.

Information furnished is believed to be accurate and reliable. However, ST assumes no responsibility for the consequences of use of such information nor for any infringement of patents or other rights of third parties which may result from its use. No license, express or implied, to any intellectual property right is granted by ST herein.

Resale of ST products with provisions different from the information set forth herein shall void any warranty granted by ST for such product.

ST and the ST logo are trademarks of ST. For additional information about ST trademarks, refer to [www.st.com/trademarks](http://www.st.com/trademarks). All other product or service names are the property of their respective owners.

Information in this document supersedes and replaces information previously supplied in any prior versions of this document.

© 2025 STMicroelectronics – All rights reserved