

Compact MCU-based control board for multi-phase and multi-motor FOC drives

Introduction

The **STEVAL-CTM020A** is a compact MCU-based control board designed for advanced motor control applications, with a special focus on multiphase and multimotor FOC drives.

Based on the STM32G474QBT microcontroller, which integrates dedicated motor control peripherals, the board provides a high-performance and flexible platform for implementing field-oriented control (FOC) and other sophisticated control algorithms.

Thanks to its multi-motor and multiphase drive capability, the **STEVAL-CTM020A** is well suited for complex motion systems that require independent or coordinated control of several electrical machines, such as induction, permanent magnet, and reluctance motors.

The control board is designed to be used in combination with external power stages or inverter boards through the MC connector V2, allowing easy adaptation to different power ratings and topologies while reusing the same control platform. Multiple feedback options can be supported, such as sensorless control, Hall-effect sensors and encoder-based sensing, depending on the specific system configuration.

The **STEVAL-CTM020A** is fully Zest-compatible and is part of the STM32 motor control ecosystem, ensuring seamless integration with ST motor control firmware libraries, configuration tools, and development environments. Debug and communication interfaces available via the STLINK connector enable straightforward tuning, monitoring, and parameterization of motor control applications.

This control board can be used as a reference design or as a development and evaluation platform for high-performance motor control in industrial applications, helping designers accelerate the implementation and optimization of advanced FOC-based multiphase and multi-motor systems.

Figure 1. STEVAL-CTM020A

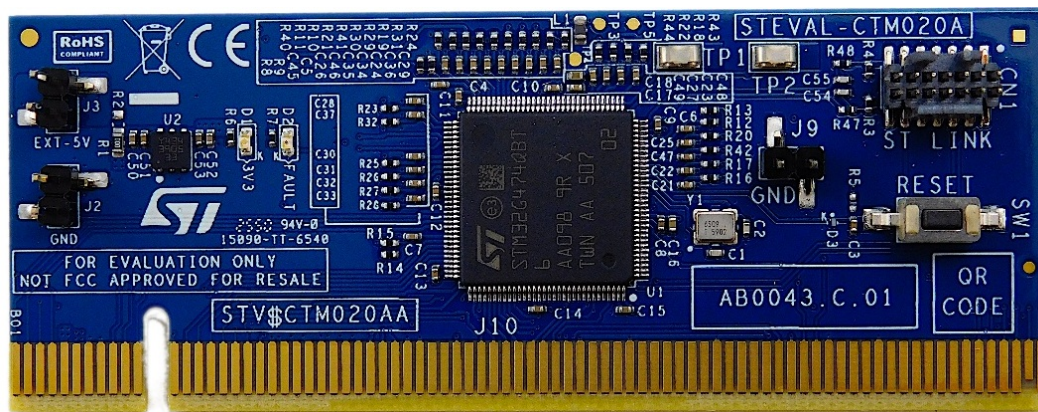

Notice: For dedicated assistance, submit a request through our online support portal at www.st.com/support.

1 Features

- Compact MCU-based control board optimized for advanced motor control applications
- Supports field-oriented control (FOC) and other advanced control algorithms
- Suitable for the implementation of control algorithms for any kind of electrical motor (PMSM, Induction, Synchronous Reluctance and switched reluctance)
- Multimotor and multiphase drive capability for complex motion systems
- Flexible hardware architecture for easy adaptation to different power stages / inverter boards, compatible with MC connector V2
- On-board STM32G474QBT microcontroller with dedicated motor control peripherals
- Designed for seamless integration with ST motor control firmware libraries and tools
- Multiple feedback options (for example, sensorless, Hall sensors, encoder) depending on system configuration
- Debug and communication interfaces for tuning, monitoring, and parameterization via the STLINK connector
- Suitable for industrial motor control applications

2 Ordering information

To order the [STEVAL-CTM020A](#) evaluation board, refer to [Table 1](#). Additional information is available from the datasheet and reference manual of the target microcontroller.

Table 1. List of available products

Order code	Board reference	Target STM32
STEVAL-CTM020A	STV\$CTM020AA ⁽¹⁾	STM32G474QBT

1. Subsequently, called control board in the rest of the documentation.

3 Development environment

System requirements

- Multi-OS support: Windows® 10, Linux® 64-bit, or macOS®

Note: macOS® is a trademark of Apple Inc., registered in the U.S. and other countries and regions.

Linux® is a registered trademark of Linus Torvalds.

Windows is a trademark of the Microsoft group of companies.

Development toolchains

- IAR Systems® - IAR Embedded Workbench®⁽¹⁾
- Keil® - MDK-Arm⁽¹⁾
- STMicroelectronics - STM32CubeIDE

1. On Windows® only.

On-board firmware

At delivery, the microcontroller on the STEVAL-CTM020A board may be programmed with a simple test firmware. This firmware is intended only for basic functional verification of the board, for example, by toggling an onboard LED or performing similar elementary checks.

This test firmware does not implement any motor control or application-level functionality. It cannot be used for evaluation or validation of the final application, such as control of an electric motor or a complete drive system.

For any development, evaluation, or testing related to the target motor control application, the user must reprogram the board. The user should use the appropriate firmware. This information is described in the following chapters of this document and in the related software documentation.

4 Quick start

Follow the sequence below to configure the [STEVAL-CTM020A](#) control board and prepare it for motor control application development (refer to [Figure 3](#) for component location):

1. Select a compatible power board

The [STEVAL-CTM020A](#) is a control board only and cannot operate a motor by itself.
 Select a compatible power board / inverter board equipped with an MC connector V2 and capable of providing the required power stage for the target motor control system.
 Refer to the www.st.com website to identify STEVAL evaluation boards or other ST power boards compatible with the MC connector V2 interface of the [STEVAL-CTM020A](#).
 2. Power supply configuration

The [STEVAL-CTM020A](#) control board can be powered in two ways:

 - From the power board through the MC connector V2, when the selected power board supports this mode.
 - From an external power supply, when the board is used in standalone mode or when the power board does not provide supply through the MC connector.

Configure the power supply according to the recommendations in this user manual and in the documentation of the selected power board, ensuring that voltage and polarity comply with the specified limits.
 3. Connection of the external programmer/debugger

Connect an external STLINK programmer/debugger (for example STLINK-V3) to the dedicated programming/debug connector on the [STEVAL-CTM020A](#).
 If required, install the corresponding STLINK USB driver on the host PC before connecting the programmer, so that the debugging interface is correctly recognized by the operating system.
 4. Motor control firmware configuration and programming

Use the STM32 motor control software development kit (X-CUBE-MCSDK) to configure the motor control firmware according to the target motor, power stage, and application requirements.
 Generate the executable image for the STM32G474QBT microcontroller and program it into the [STEVAL-CTM020A](#) using the connected STLINK and the preferred development environment (for example STM32CubeIDE or another supported IDE).
- Note:* *Before using the board, check that the NSWBOOT0 option byte is unchecked and the NBOOT0 option byte is checked. Use STM32CubeProgrammer to perform this setting, and refer to the user manual for detailed instructions.*
5. Application debug and fine-tuning

After successful programming, perform debug and fine-tuning of the motor control application by using the tools and procedures described in the MCSDK documentation (for example, parameter tuning, monitoring and real-time debugging).
 Follow the safety recommendations and application notes provided for the selected motor, power board, and final system to ensure safe operation during testing and optimization.

5 Hardware layout and configuration

Hardware block diagram

The STEVAL-CTM020A evaluation board is designed with the STM32G474QBT target microcontroller. The Figure 2 illustrates STM32G474QBT connections with peripheral components. The Figure 3 helps to locate these features on the STEVAL-CTM020A evaluation board.

Figure 2. Hardware block diagram

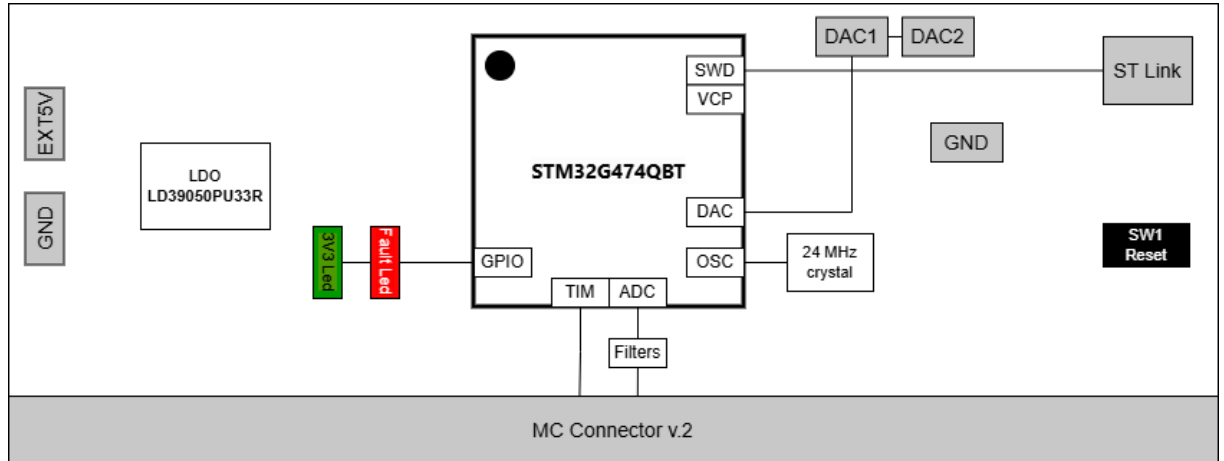
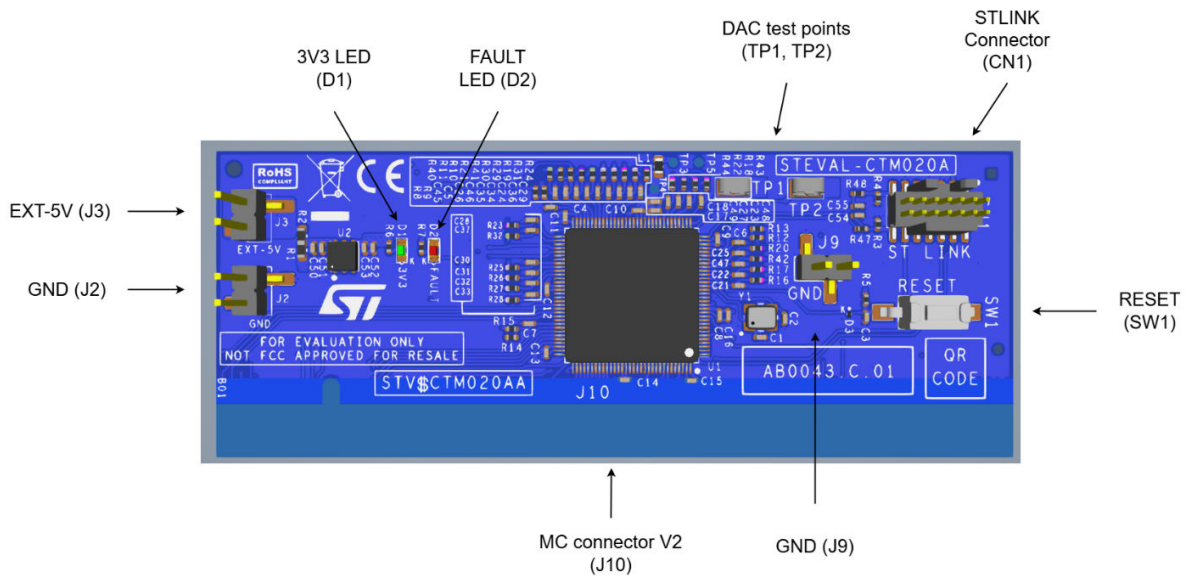

Figure 3. STEVAL-CTM020A PCB layout (top view)



6 External debugging tool

6.1 Description

The [STEVAL-CTM020A](#) does not embed any on-board STLINK circuitry. Programming and debugging of the STM32G474QBT microcontroller are performed exclusively by means of an external debugging tool, such as STLINK-V3SET or a compatible SWD probe, connected to the dedicated debug connector CN1.

The CN1 connector provides the standard Serial Wire Debug (SWD) signals, target reset, and reference supply required by the external debugger to interface with the on-board STM32 microcontroller. When properly connected and powered, the external debugging tool can be used to:

- Program the application firmware into the internal flash memory of the STM32G474QBT
- Perform run-control debug operations (run, halt, single-step, breakpoints)
- Monitor and tune the motor control application, in combination with the STM32 development tools and the MCSDK utilities.

The [STEVAL-CTM020A](#) must be powered either from a compatible power board through the MC connector V2 or from an appropriate external power supply, according to the power configuration described in this user manual. The external debugging tool does not supply power to the board through CN1.

6.2 Drivers

Before using an external STLINK-based debugging tool (for example STLINK-V3SET) with a Windows® PC, the user must ensure that the corresponding STLINK USB driver is installed on the host computer.

The latest version of the STLINK driver package is available on the www.st.com website.

If the debugging tool is connected to the PC before the driver installation is completed, some interfaces might appear as unknown devices in the device manager. In this case, the user must install the dedicated STLINK driver package and then update the device driver from the Windows device manager.

6.3 Use of an external debugging tool to program and debug the on-board STM32

To program and debug the STM32G474QBT microcontroller on the [STEVAL-CTM020A](#) by means of an external debugging tool, proceed as follows:

- Power the [STEVAL-CTM020A](#)
- Ensure that the control board is correctly powered either from the selected power board via the MC connector V2, or from a suitable external power supply, as described in the power supply section of this user manual
- Connect the external debugging tool to CN1
- Connect the SWD cable from the external STLINK-V3SET (or equivalent tool) to the CN1 debug connector, carefully matching the pin-1 orientation and the SWD signal mapping (SWDIO, SWCLK, NRST, GND, VDD)
- Connect the debugging tool to the host PC via USB
- Verify on the development environment (for example STM32CubeIDE or another supported IDE) that the target STM32G474QBT on the [STEVAL-CTM020A](#) is correctly detected
- Program and debug the application

Load the motor control application or test firmware generated with the X-CUBE-MCSDK or other STM32 software packages, and program it into the target microcontroller.

Use the debugging features of the selected IDE (breakpoints, watch windows, variable monitoring, etc.) to develop, verify, and fine-tune the motor control application running on the [STEVAL-CTM020A](#).

All programming and debugging operations must be carried out in compliance with the safety instructions and the electrical limits of both the [STEVAL-CTM020A](#) and the connected power board, especially when operating with energized motor loads.

7 Debug/communication connector (CN1)

Description

The CN1 connector on the [STEVAL-CTM020A](#) provides the interface for both:

- programming and debugging the on-board STM32G474QBT microcontroller via the Serial Wire Debug (SWD) interface (and optional Serial Wire Viewer - SWV), and
- serial communication between the target microcontroller and the host PC or another external system, using a USART channel typically exposed as a Virtual COM Port (VCP) by the external debugging tool (for example STLINK-V3SET).

CN1 is a 14-pin, 1.27 mm pitch header, compatible with standard STDC14/MIPI-10 style SWD connections, and includes additional pins for the USART TX/RX signals and target supply reference.

When an external STLINK-based debugging tool is connected to CN1, it can:

- access the SWDIO, SWCLK, NRST and SWO lines for in-circuit programming and debugging of the STM32G474QBT, and
- route the target USART TX/RX lines to a Virtual COM Port on the host PC, enabling serial communication for logging, monitoring and parameter tuning of the motor control application.

CN1 does not supply power to the STEVAL-CTM020A. The board must be powered separately, either from a compatible power board via the MC connector V2 or from an external supply, as described in the power supply section of this user manual.

CN1 connector pinout

Figure 4 shows the CN1 connector pinout (top view, pin-1 marking on the PCB silkscreen).

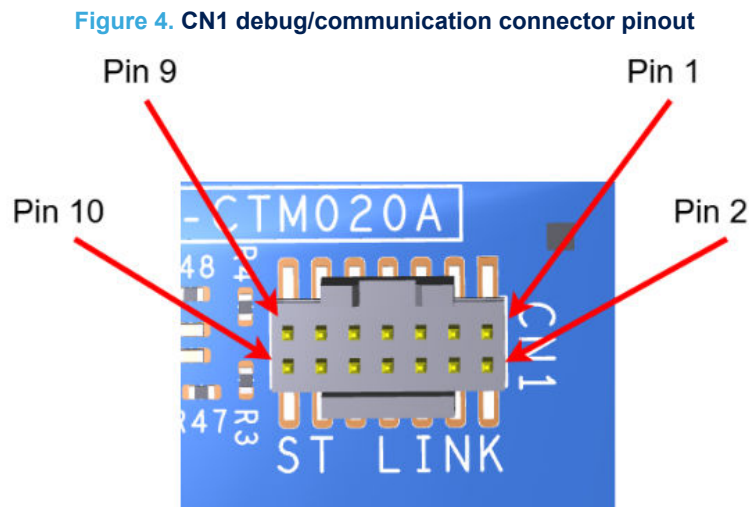

The [Table 2](#) describes the CN1 connector pinout and signal assignment.

Table 2. CN1 debug / communication connector pinout

Pin number	STM32 signal	Board function
1	NC	Not connected
2	NC	Not connected
3	VDD	Target VDD reference for debugger
4	PA13	`JTMS_SWDIO` – SWDIO line
5	GND	Ground
6	PA14	`JTCK_SWCLK` – SWCLK line
7	GND	Ground
8	NC	Not connected
9	NC	Not connected
10	NC	Not connected
11	GND	Ground
12	NRST	Target reset (active LOW)
13	PA3	USART RX (target RX ← debugger TX / VCP)
14	PA2	USART TX (target TX → debugger RX / VCP)

8 MC connector V2

Description

MC connector V2 is a new generation interface between the control board and the power board (or adaptor board). It is a PCI Express® format connector. On [STEVAL-CTM020A](#), this connector is a PCI-E 16x edge-finger. Three motors, PFC, SPI, and ADC signals are implemented on MC connector V2. The signals of the second motor (Motor 2) are shared with other board interfaces according to the hardware configuration.

Pinout

Table 3. MC connector V2 describes the pinout of the CN5 MC connector V2.

Table 3. MC connector V2

Pin number	Category	Pin name	STM32 signal	Function of STEVAL-CTM020 A	Comment
A side					
1	SPI	SPI_nSS	PG1	DIGIT_ENC1_SPI_CS	–
2	SPI	SPI_SCK	PG2	DIGIT_ENC1_SPI_SCK	–
3	SPI	SPI_nSS	PB8	DIGIT_ENC2_SPI_CS	–
4	SPI	SPI_SCK	PB3	DIGIT_ENC2_SPI_SCK	–
5	–	5V_to_CTRL		MC_5V	–
6	–	3.3V_to_PWR	VDD	3v3	–
7	–	DGND	VSS	GND	–
8	–	ID_Enable	–	–	–
9	ADC	ADC_A9	PD13	TEMP_SENS_4	Analog input filter
10	ADC	ADC_A10	PE10	TEMP_SENS_5	Analog input filter
11	ADC	ADC_A11	PE11	TEMP_SENS_6	Analog input filter
12	Motor	Emergency(BKIN)	PB10	EMERGENCY_1	–
13	Motor	INH/PWM	PA8	PWM_HS1/ HRTIM1_TA1	–
14	Motor	INH/PWM	PA9	PWM_HS2/ HRTIM1_TA2	–
15	Motor	INH/PWM	PA10	PWM_HS3/ HRTIM1_TB1	–
16	IO	Master_EN	PF2	DIGITAL_OUT1	–
17	–	Timer_ETR	–	–	–
18	Motor	Hall_sensors_H1	PD3	POS_SENS_HALL 1_H1	–
19	Motor	Hall_sensors_H2	PD4	POS_SENS_HALL 1_H2	–
20	–	DGND	VSS	GND	–
21	Motor	Shunt+	PC0	PHASE_CURR_S ENS_1	Analog input filter
22	Motor	Shunt+	PA7	PHASE_CURR_S ENS_2	Analog input filter

Pin number	Category	Pin name	STM32 signal	Function of STEVAL-CTM020 A	Comment
23	Motor	Shunt+	PB1	PHASE_CURR_SENS_3	Analog input filter
24	–	AGND	VSS	GND	–
25	Motor	Ph_Voltage+/ BEMF_zc	PC2	INV_OUT_VOLT_SENS_1	Analog input filter
26	Motor	Ph_Voltage+/ BEMF_zc	PC3	INV_OUT_VOLT_SENS_2	Analog input filter
27	Motor	Ph_Voltage+/ BEMF_zc	PE13	INV_OUT_VOLT_SENS_3	Analog input filter
28	Motor	Temperature/Board ID	PD10	TEMP_SENS_1	Analog input filter
29	Motor	VBUS	PE8	VDC_BUS_SENS	Analog input filter
30	Motor	Dissipative_brake	PE1	DISSIPATIVE_BRAKE	–
31	–	DGND	VSS	GND	–
32	–	AGND	VSS	GND	–
33	–	AC_voltage	–	–	–
34	–	PFC_Current1	–	–	–
35	–	PFC_BKIN_OCP	–	–	–
36	–	PFC_PWM1	–	–	–
37	Motor	Emergency(BKIN)	PA0	EMERGENCY_3	–
38	Motor	INH/PWM	PA15	PWM_HS4	–
39	Motor	INH/PWM	PC7	PWM_HS5/ HRTIM1_TF2	–
40	Motor	INH/PWM	PC8	PWM_HS6/ HRTIM1_TE1	–
41	IO	Master_EN	PF3	DIGITAL_OUT2	–
42	–	Timer_ETR	–	–	–
43	Motor	Hall_sensors_H1	PB2	POS_SENS_ENC3_A/ HALL2_H1	Shared
44	Motor	Hall_sensors_H2	PF7	POS_SENS_ENC3_B/ HALL2_H2	Shared
45	–	DGND	VSS	GND	–
46	Motor	Shunt+	PC1	PHASE_CURR_SENS_4	Analog input filter
47	Motor	Shunt+	PC4	PHASE_CURR_SENS_5	Analog input filter
48	Motor	Shunt+	PE9	PHASE_CURR_SENS_6	Analog input filter
49	–	AGND	VSS	GND	–
50	Motor	Ph_Voltage+/ BEMF_zc	PC5	INV_OUT_VOLT_SENS_4	Analog input filter
51	Motor	Ph_Voltage+/ BEMF_zc	PB11	INV_OUT_VOLT_SENS_5	Analog input filter
52	Motor	Ph_Voltage+/ BEMF_zc	PE7	INV_OUT_VOLT_SENS_6	Analog input filter

Pin number	Category	Pin name	STM32 signal	Function of STEVAL-CTM020 A	Comment
53	Motor2	Temperature/Board ID	PD11	TEMP_SENS_2	Analog input filter
54	–	VBUS	–	–	–
55	–	Dissipative_brake	–	–	–
56	–	DGND	VSS	GND	–
57	–	Emergency(BKIN)	–	–	–
58	Motor	INH/PWM	PB13	HRTIM1_TC2	–
59	–	INH/PWM	–	–	–
60	–	INH/PWM	–	–	–
61	IO	Master_EN	PF4	DIGITAL_OUT3	–
62	–	Timer_ETR	–	–	–
63	Motor	Hall_sensors_H1	PB6	POS_SENS_ENC2_A/HALL3_H1	Shared
64	Motor3	Hall_sensors_H2	PB7	OS_SENS_ENC2_B/HALL3_H2	Shared
65	–	DGND	VSS	GND	–
66	–	Shunt+	–	–	–
67	–	Shunt+	–	–	–
68	–	Shunt+	–	–	–
69	–	AGND	VSS	GND	–
70	–	Ph_Voltage+/BEMF_zc	–	–	–
71	–	Ph_Voltage+/BEMF_zc	–	–	–
72	–	Ph_Voltage+/BEMF_zc	–	–	–
73	Motor	Temperature/Board ID	PD12	TEMP_SENS_3	Analog input filter
74	–	VBUS	–	–	–
75	–	Dissipative_brake	–	–	–
76	–	DGND	VSS	GND	–
77	IO	SD_CLKO/SPI_nSS	PF5	DIGITAL_OUT4	–
78	IO	SD_DIN/Enable	PG5	DIGITAL_OUT5	–
79	IO	SD_CLKO/SPI_nSS	PG6	DIGITAL_OUT6	–
80	IO	SD_DIN/Enable	PG7	DIGITAL_OUT7	–
81	IO	SD_CLKO/SPI_nSS	PG8	DIGITAL_OUT8	–
82	–	SD_DIN/Enable	–	–	–
B side					
1	SPI	SPI_MISO	PG3	DIGIT_ENC1_SPI_MISO	–
2	SPI	SPI_MOSI	PG4	DIGIT_ENC1_SPI_MOSI	–

Pin number	Category	Pin name	STM32 signal	Function of STEVAL-CTM020 A	Comment
3	SPI	SPI_MISO	PB4	DIGIT_ENC2_SPI_MISO	–
4	SPI	SPI_MOSI	PB5	DIGIT_ENC2_SPI_MOSI	–
5	–	5V_to_CTRL	–	MC_5V	–
6	–	VREF+	–	–	–
7	–	DGND	VSS	GND	–
8	–	AGND	VSS	GND	–
9	–	ADC	–	–	–
10	PWM	PWM	PB14	HRTIM1_TD1	–
11	PWM	PWM	PB15	HRTIM1_TD2	–
12	Motor	Emergency(BKIN2)	PE14	EMERGENCY_2	–
13	Motor	INL/EN	PA11	PWM_LS1/ HRTIM1_TB2	–
14	Motor	INL/EN	PA12	PWM_LS2	–
15	Motor	INL/EN	PB9	PWM_LS3	–
16	Motor	Encoder_A	PC6	POS_SENS_ENC1_A	–
17	Motor1	Encoder_B	PE3	POS_SENS_ENC1_B	–
18	Motor1	Encoder_Z	PD2	POS_SENS_ENC1_Z	–
19	Motor	Hall_sensors_H3	PD7	POS_SENS_HALL_1_H3	–
20	–	DGND	VSS	GND	–
21	Motor	Shunt-	VSS	GND	–
22	Motor	Shunt-	VSS	GND	–
23	Motor	Shunt-	VSS	GND	–
24	–	AGND	VSS	GND	–
25	Motor	Ph_Voltage-/ BEMF_ref	VSS	GND	–
26	Motor	Ph_Voltage-/ BEMF_ref	VSS	GND	–
27	Motor	Ph_Voltage-/ BEMF_ref	VSS	GND	–
28	Motor	Res.Ex/Curr.REF	PA6	RES1_EXC	–
29	Motor1	Resolver_Sin/ GPIO_BEMF	PE15	RES1_SIN	Analog input filter
30	Motor1	Resolver_Cos	PE12	RES1_COS	Analog input filter
31	–	DGND	VSS	GND	–
32	–	AGND	VSS	GND	–
33	–	AC_zero_crossing	–	–	–
34	–	PFC_Current2	–	–	–
35	ICL	Inrush_lim.	PD15	INRUSH_CURR_LIMIT	–

Pin number	Category	Pin name	STM32 signal	Function of STEVAL-CTM020 A	Comment
36	–	PFC_PWM2	–	–	–
37	Motor	Emergency(BKIN2)	PC9	EMERGENCY_4	–
38	Motor	INL/EN	PC10	PWM_LS4	–
39	Motor	INL/EN	PC11	PWM_LS5	–
40	Motor	INL/EN	PC12	PWM_LS6	–
41	Motor	Encoder_A	PB6	POS_SENS_ENC2_A/HALL3_H1	Shared
42	Motor	Encoder_B	PB7	POS_SENS_ENC2_B/HALL3_H2	Shared
43	Motor	Encoder_Z	PE0	POS_SENS_ENC2_Z	–
44	Motor	Hall_sensors_H3	PF8	POS_SENS_HALL_2_H3	–
45	–	DGND	VSS	GND	–
46	–	Shunt-	–	–	–
47	–	Shunt-	–	–	–
48	–	Shunt-	–	–	–
49	–	AGND	VSS	GND	–
50	–	Ph_Voltage-/BEMF_ref	–	–	–
51	–	Ph_Voltage-/BEMF_ref	–	–	–
52	–	Ph_Voltage-/BEMF_ref	–	–	–
53	–	Res.Ex/Curr.REF	–	–	–
54	–	Resolver_Sin/GPIO_BEMF	–	–	–
55	–	Resolver_Cos	–	–	–
56	–	AGND	VSS	GND	–
57	–	Emergency(BKIN2)	–	–	–
58	–	INL/EN	–	–	–
59	–	INL/EN	–	–	–
60	–	INL/EN	–	–	–
61	Motor	Encoder_A	PB2	POS_SENS_ENC3_A/HALL2_H1	Shared
62	Motor	Encoder_B	PF7	POS_SENS_ENC3_B/HALL2_H2	Shared
63	Motor	Encoder_Z	PF6	POS_SENS_ENC3_Z	–
64	Motor	Hall_sensor_H3	PD14	POS_SENS_HALL_3_H3	–
65	–	DGND	VSS	GND	–
66	–	Shunt-	–	–	–
67	–	Shunt-	–	–	–
68	–	Shunt-	–	–	–

Pin number	Category	Pin name	STM32 signal	Function of STEVAL-CTM020 A	Comment
69	–	AGND	VSS	GND	–
70	–	Ph_Voltage-/BEMF_ref	–	–	–
71	–	Ph_Voltage-/BEMF_ref	–	–	–
72	–	Ph_Voltage-/BEMF_ref	–	–	–
73	–	Res.Ex/Curr.REF	–	–	–
74	–	Resolver_Sin/ GPIO_BEMF	–	–	–
75	–	Resolver_Cos	–	–	–
76	–	AGND	VSS	GND	–
77	Motor	SD_DIN/Enable	PF10	RELAY_CMD/ ENABLE 1	–
78	Motor	SD_DIN/Enable	PF11	RELAY_CMD/ ENABLE 2	–
79	Motor	SD_DIN/Enable	PF12	RELAY_CMD/ ENABLE 3	–
80	Motor	SD_DIN/Enable	PF13	RELAY_CMD/ ENABLE 4	–
81	Motor	SD_DIN/Enable	PF14	RELAY_CMD/ ENABLE 5	–
82	Motor	SD_DIN/Enable	PF15	RELAY_CMD/ ENABLE 6	–

9 DAC-based debug functionality

The STM32G474QBT microcontroller mounted on the STEVAL-CTM020A features an on-chip digital-to-analog converter (DAC) with two independent channels. On this board, both DAC channels can be used for debug and monitoring purposes, by converting selected internal variables into analog voltage waveforms that can be observed with an oscilloscope.

Typical use cases include the real-time visualization of quantities that vary at the motor control loop frequency or faster, such as:

- motor electrical angle
- back-EMF (BEMF) related quantities
- current or speed controller internal variables

The DAC-based debug functionality is fully controlled by software. The application firmware must configure the DAC channels, select the variables to be converted, and update the DAC outputs at the desired rate. The STM32 Motor Control Software Development Kit (X-CUBE-MCSDK) supports this feature and can be used to route internal motor control variables to the DAC outputs for advanced debugging and tuning.

On the STEVAL-CTM020A, the analog signals generated by the two DAC channels are made available on dedicated test points:

- TP1: DAC channel 1 output
- TP2: DAC channel 2 output

Figure 5 shows the location of TP1 and TP2 on the PCB.

To observe the corresponding analog waveforms, connect the oscilloscope voltage probes to these test points, ensuring proper reference to the board ground (GND) and respecting the electrical constraints specified for the DAC outputs.

Figure 5. TP1-TP2 DAC-based debug functionality

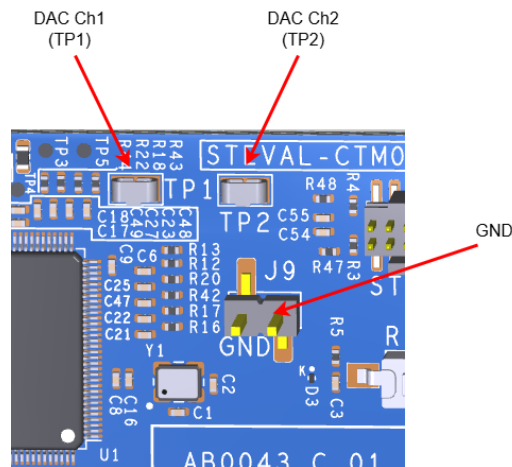

10 Power supply options and configuration

The STEVAL-CTM020A control board is supplied with a nominal 5 V DC input, which is then regulated down to 3.3 V by the on-board LD39050PU33R LDO regulator to power the STM32G474QBT microcontroller and associated circuitry.

The board supports two alternative 5 V input sources:

- EXT_5V connector (J3)
- MC connector V2 (J10), pin A5 – 5V_to_CTRL

The selection and routing of the 5 V supply to the LDO regulator are implemented by means of two resistors, R1 and R2, which act as solder bridges:

- R1 connects the 5V_to_CTRL line from the MC connector J10 (pin A5) to the LDO input
- R2 connects the EXT_5V input from connector J3 to the LDO input

Only the 5 V input that is actually routed to the LDO (through R1 and/or R2) will be used to generate the on-board 3.3 V supply. The user must configure the power supply option by populating the appropriate resistor(s) according to the intended usage.

Caution: *When both R1 and R2 are populated, only one 5 V source must be applied at a time (either via J10 or via J3), in order to avoid any conflict between power supplies and potential damage to the board or connected equipment.*

Power supply configuration options

Table 4 summarizes the recommended power supply configurations for the STEVAL-CTM020A (the case where both R1 and R2 are not populated is not considered, as the board would not be powered).

Table 4. Power supply configuration options

Configuration ID	R1 (J10→LDO)	R2 (J3→LDO)	Active 5 V input source	Notes
1	Mounted	Not mounted	MC connector J10, pin A5 (5V_to_CTRL)	Board is powered from the compatible power board / inverter through the MC connector V2
2	Not mounted	Mounted	EXT_5V connector J3	Board is powered from an external 5 V supply via the EXT_5V connector (stand-alone operation)
3	Mounted	Mounted	J10 or J3 (only one enabled at a time)	User must apply 5 V either on J10 or on J3, but never on both simultaneously

In all configurations, the input voltage must comply with the specified 5 V operating range of the LD39050PU33R regulator and the absolute maximum ratings of the board.

11 Using STEVAL-CTM020A with the STM32 Motor Control SDK (X-CUBE-MCSDK)

The STEVAL-CTM020A control board is specifically intended to be used in motor control applications based on the STM32 Motor Control Software Development Kit (X-CUBE-MCSDK).

In principle, the hardware architecture of the board allows the implementation of advanced control schemes for a wide range of motor types, including:

- asynchronous (AC induction) motors
- synchronous reluctance motors
- multi-phase motors (for example up to six phases)
- and other brushless topologies for which ready-to-use firmware examples may not yet be available

However, when the board is used to drive three-phase permanent-magnet synchronous motors (PMSM), the application firmware can be generated directly with the X-CUBE-MCSDK, which can be downloaded from the www.st.com website. The Motor Control Workbench, included in the MCSDK, guides the user through the configuration of the motor, power stage and control parameters and automatically generates the corresponding STM32 project.

The MCSDK board configurator is continuously updated to support new ST reference boards. If the STEVAL-CTM020A is listed among the supported boards, it can be selected directly in the Workbench and used as the starting point for the project generation.

If the STEVAL-CTM020A is not yet present in the standard MCSDK board list, it is still possible to start from a pre-configured example by using an MCSDK-PKG expansion package, also available on www.st.com. These expansion packages extend the MCSDK offer by:

- – adding application-specific examples, and
- – expanding the set of hardware boards available in the MCSDK Workbench

A typical usage flow with an MCSDK-PKG expansion package is as follows:

1. Download and extract the selected MCSDK-PKG expansion package
2. Open the included readme file for a detailed description of the package content and usage. Copy the chosen example folder into the preferred workspace, without changing the folder name
3. Open the associated .ioc file with the Motor Control Workbench
4. Customize the configuration according to the specific application (for example motor parameters, speed loop settings, protection thresholds), within the limits of the editable parameters
5. Save the project without changing its location and click “Generate the project”, selecting the preferred supported IDE (for example STM32CubeIDE)
6. Open the generated project in the selected IDE, build the application and program the STEVAL-CTM020A through the external debugging tool (for example STLINK-V3SET)

Once programmed, the application can be debugged and fine-tuned using the standard MCSDK tools and features (real-time monitoring, parameter tuning, DAC-based debug outputs, Virtual COM Port communication, and so on), as described in the MCSDK documentation and in the previous sections of this user manual.

12 Schematic diagrams

Figure 6. STEVAL-CTM020A circuit schematic (1 of 26)

Temperature and DC Voltage Filters

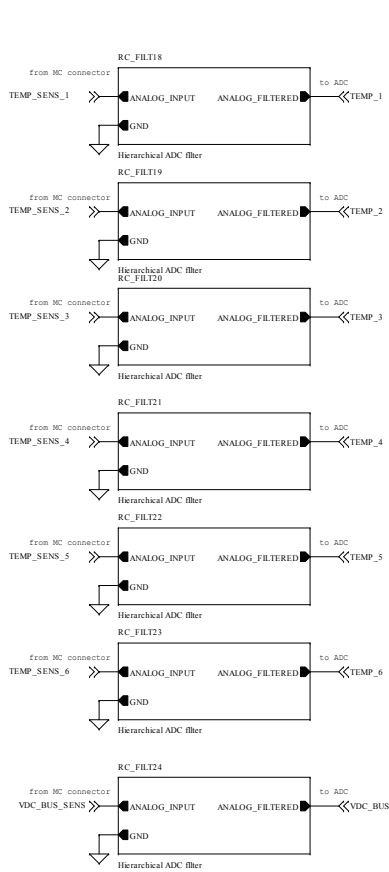

Phase Current Filters

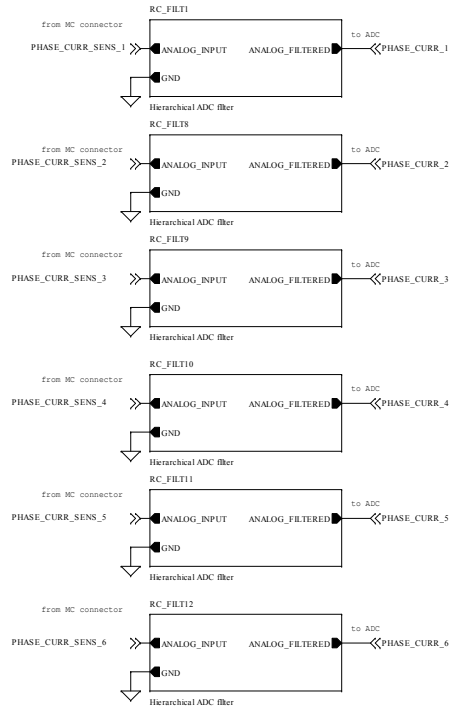

Resolver signals filters



Inverter Output Voltage Filters

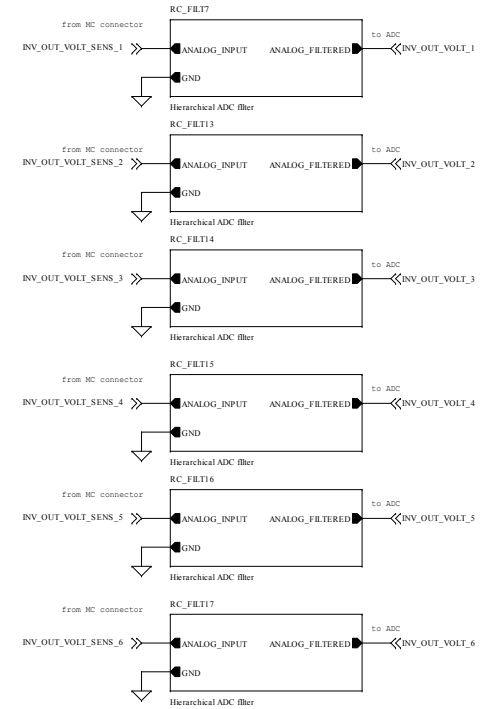

User Analog Input Filters

Figure 7. STEVAL-CTM020A circuit schematic (2 of 26)

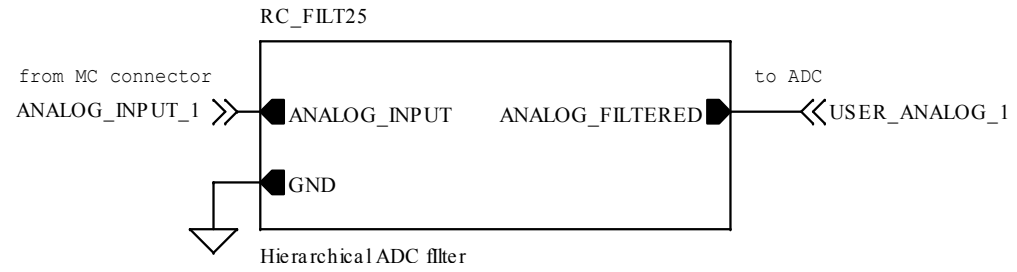
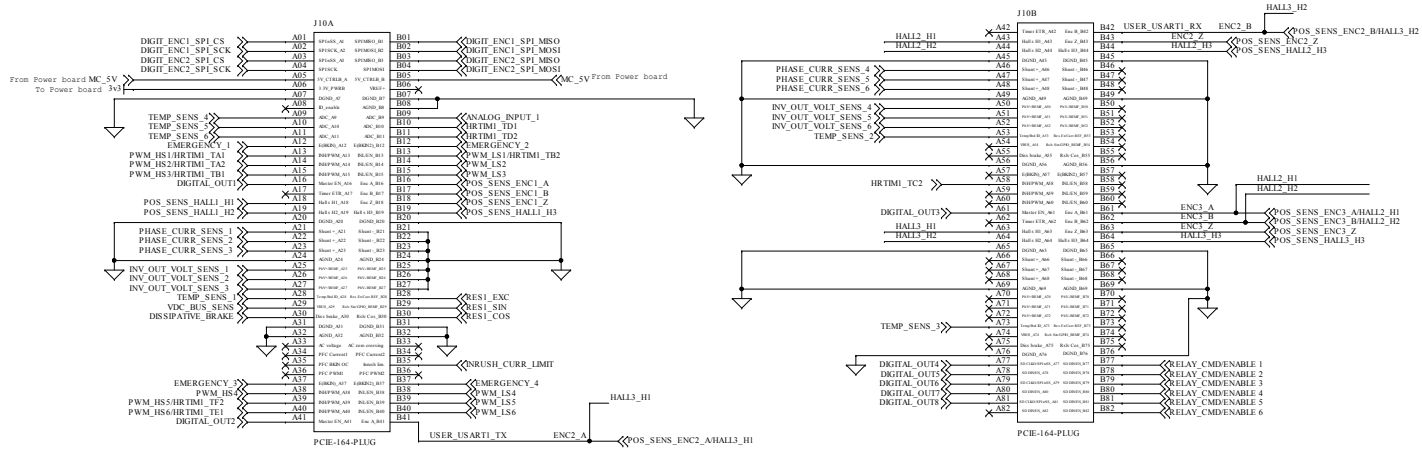
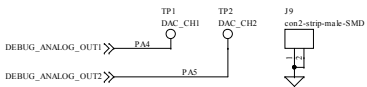

Figure 8. STEVAL-CTM020A circuit schematic (3 of 26)

Motor Control (MC) Connector



Debug Signals - MCU DACs



5V selection - MC Connector/External

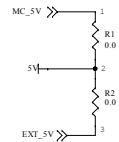
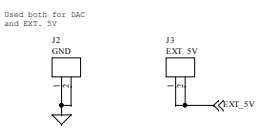

5V Selection Table

MC_5V	EXT_5V
1-2	Closed
2-3	Open

STLinkV3 Connector

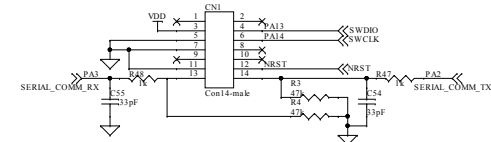

Figure 9. STEVAL-CTM020A circuit schematic (4 of 26)

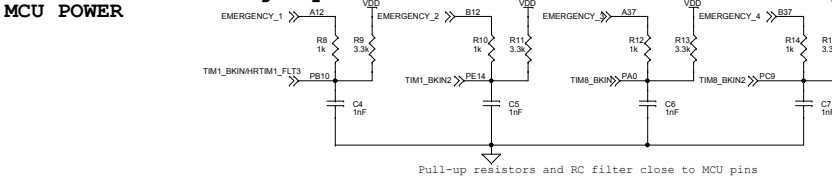
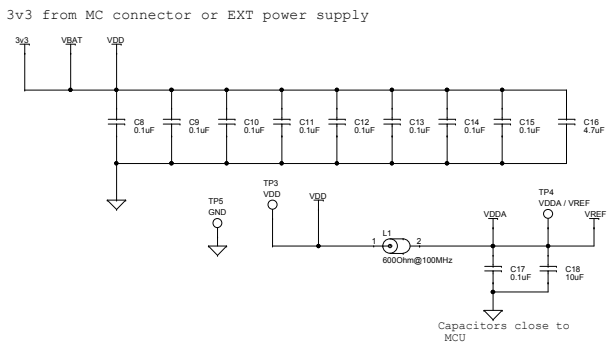
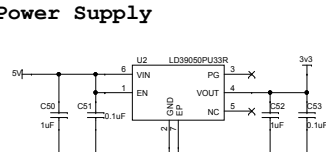
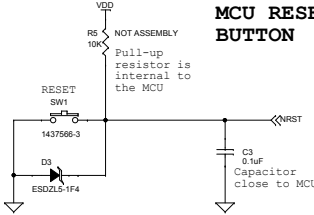
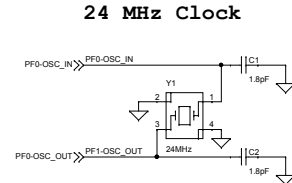
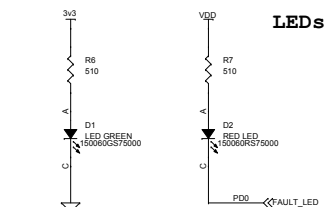
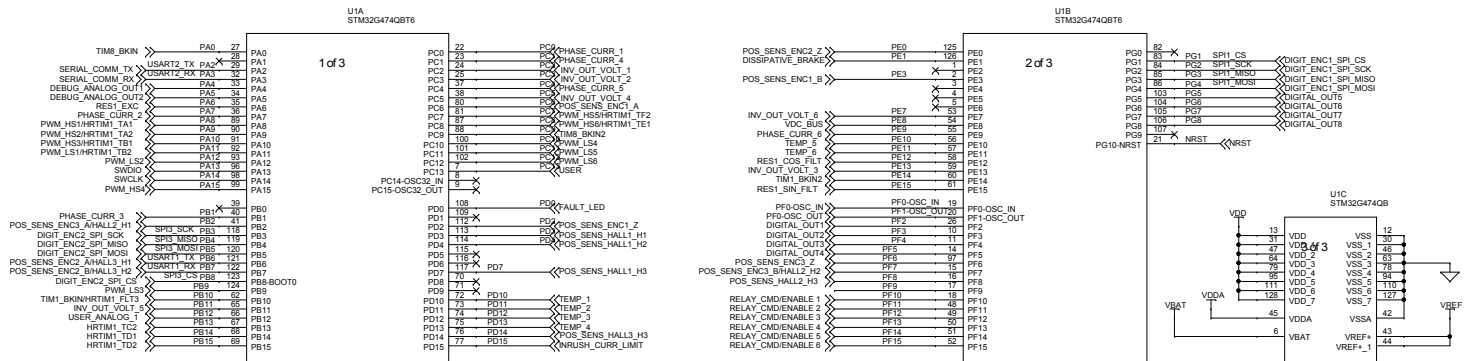

Figure 10. STEVAL-CTM020A circuit schematic (5 of 26)
RC filter close to MCU pin

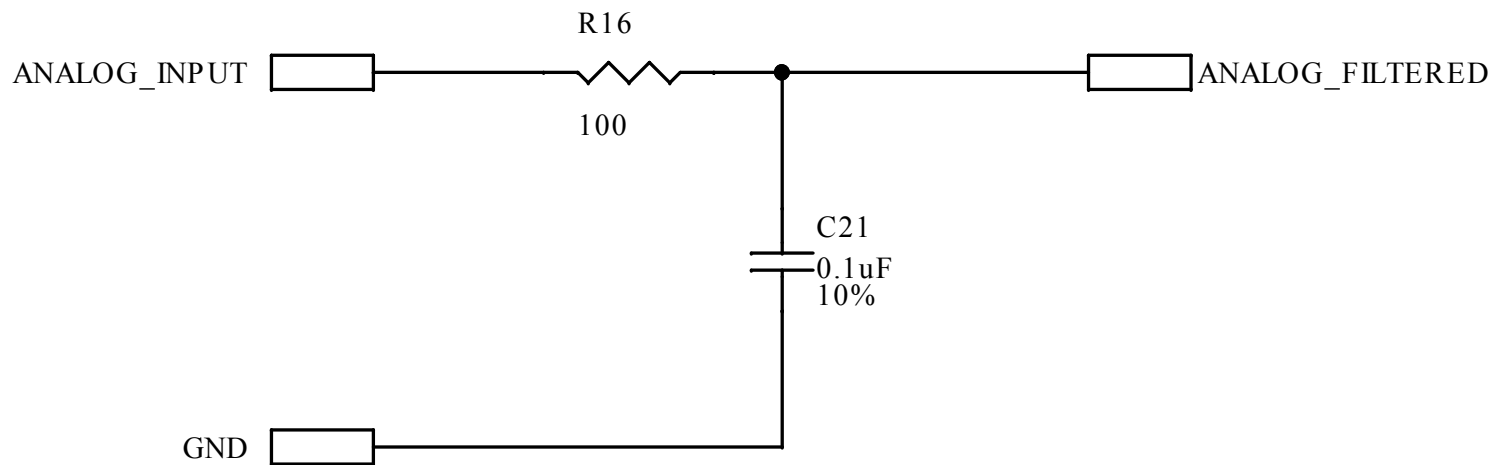

Figure 11. STEVAL-CTM020A circuit schematic (6 of 26)
RC filter close to MCU pin

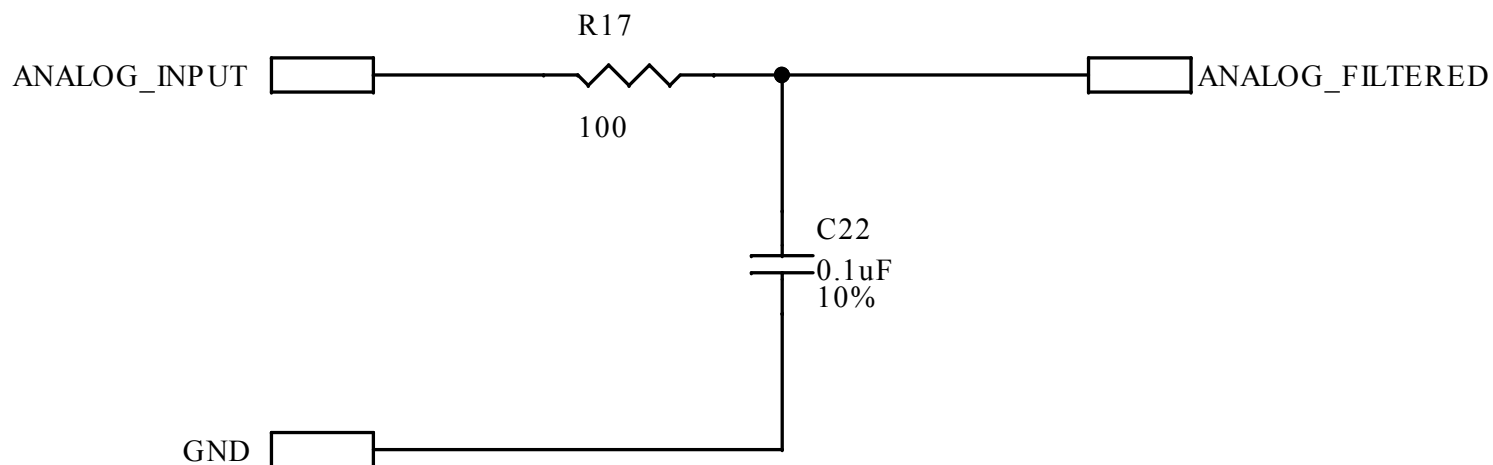

Figure 12. STEVAL-CTM020A circuit schematic (7 of 26)
RC filter close to MCU pin

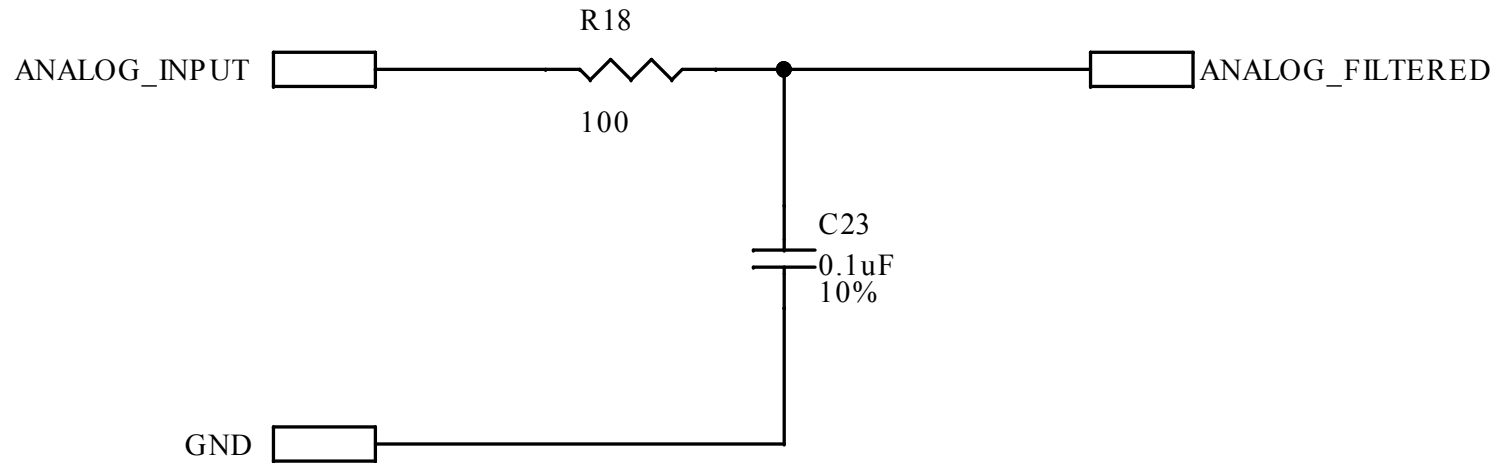

Figure 13. STEVAL-CTM020A circuit schematic (8 of 26)
RC filter close to MCU pin

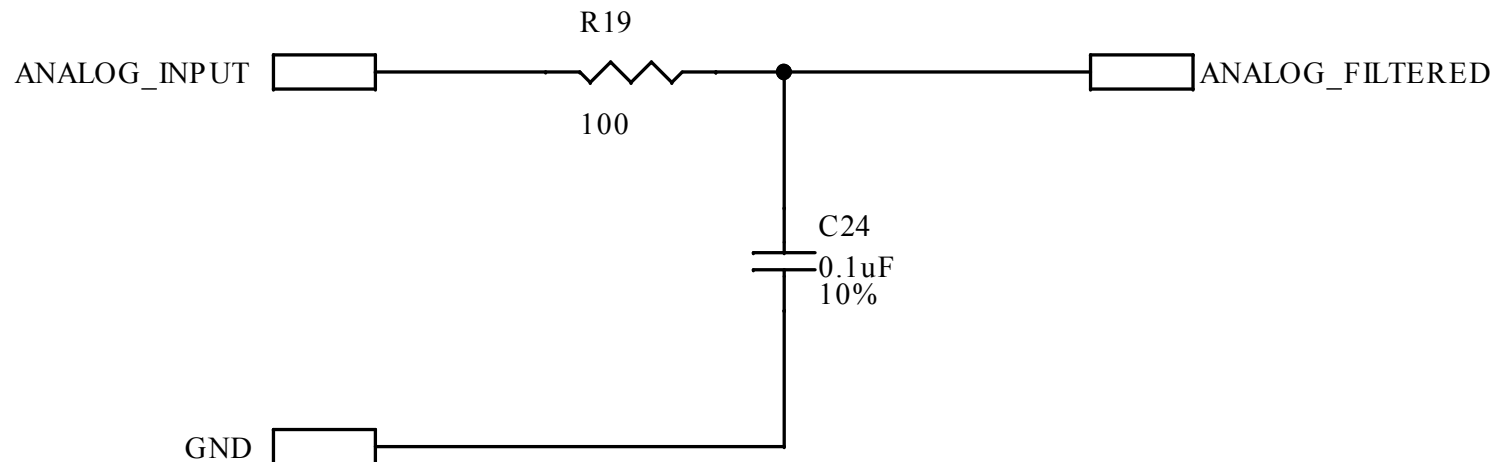

Figure 14. STEVAL-CTM020A circuit schematic (9 of 26)
RC filter close to MCU pin

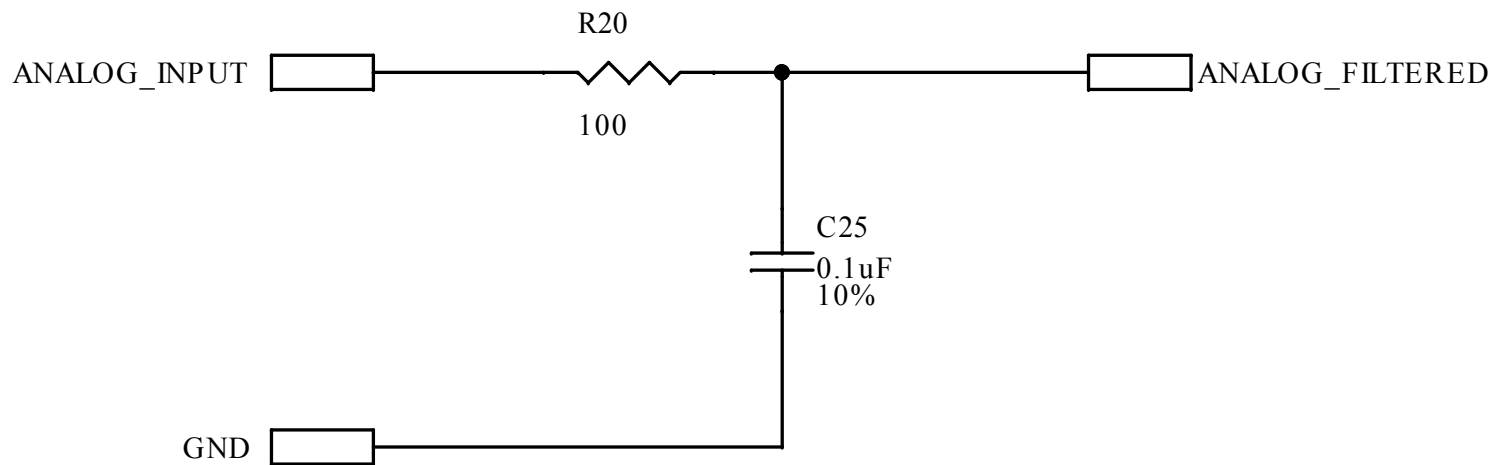

Figure 15. STEVAL-CTM020A circuit schematic (10 of 26)
RC filter close to MCU pin

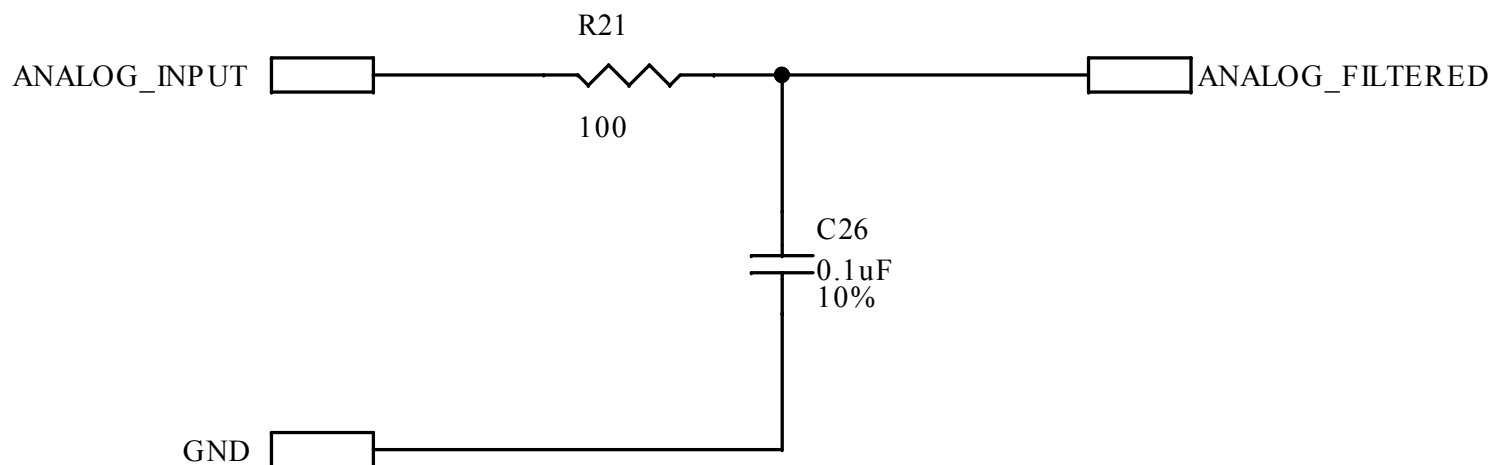

Figure 16. STEVAL-CTM020A circuit schematic (11 of 26)
RC filter close to MCU pin

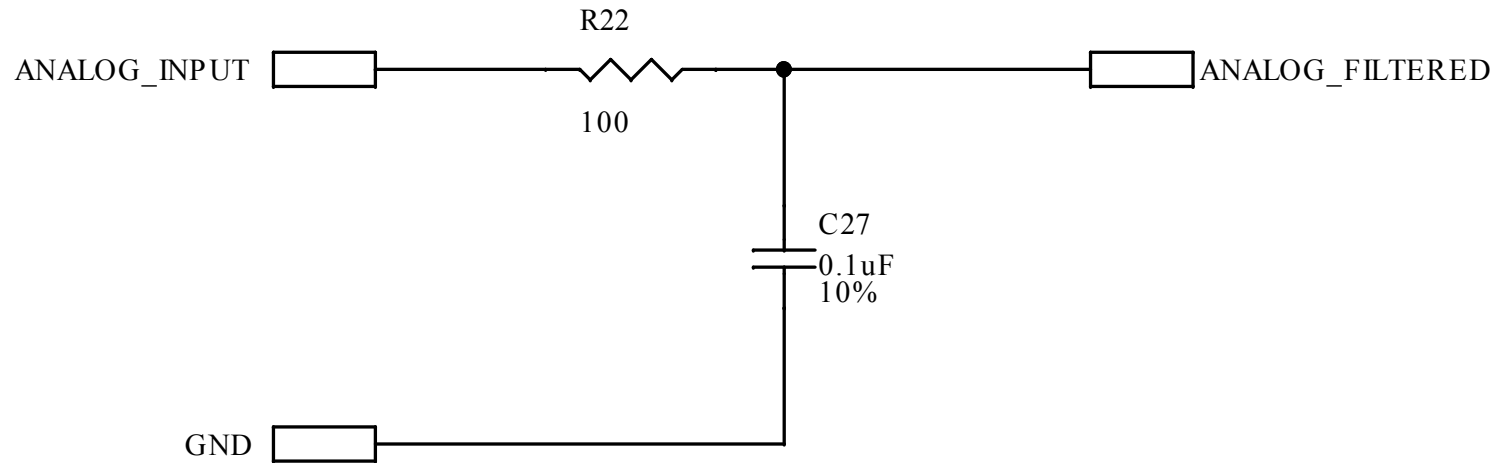

Figure 17. STEVAL-CTM020A circuit schematic (12 of 26)
RC filter close to MCU pin

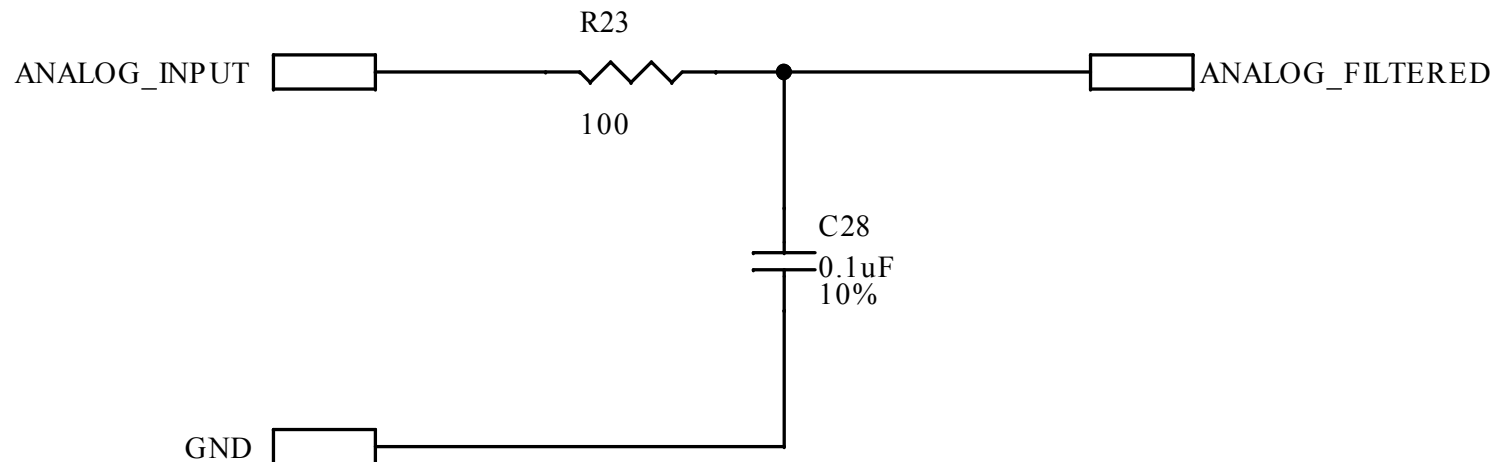

Figure 18. STEVAL-CTM020A circuit schematic (13 of 26)
RC filter close to MCU pin

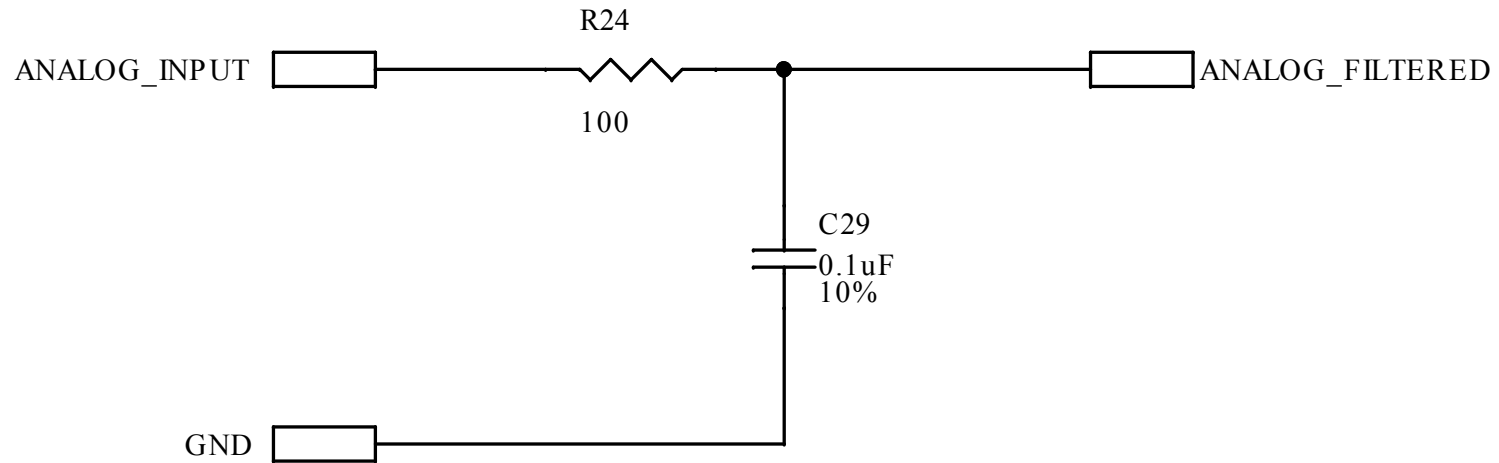

Figure 19. STEVAL-CTM020A circuit schematic (14 of 26)
RC filter close to MCU pin

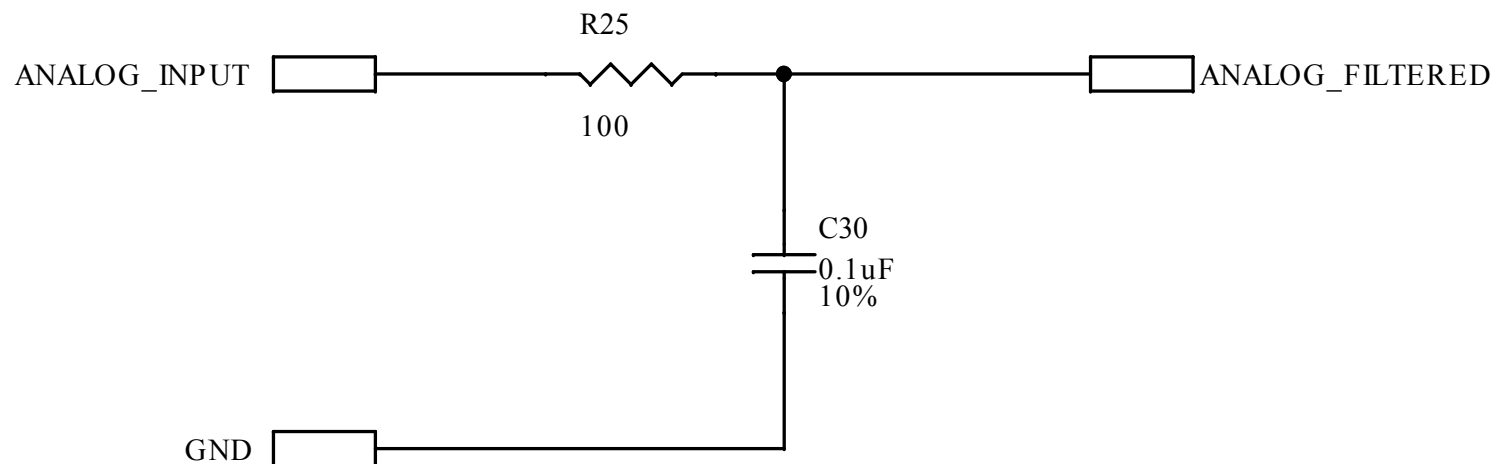

Figure 20. STEVAL-CTM020A circuit schematic (15 of 26)
RC filter close to MCU pin

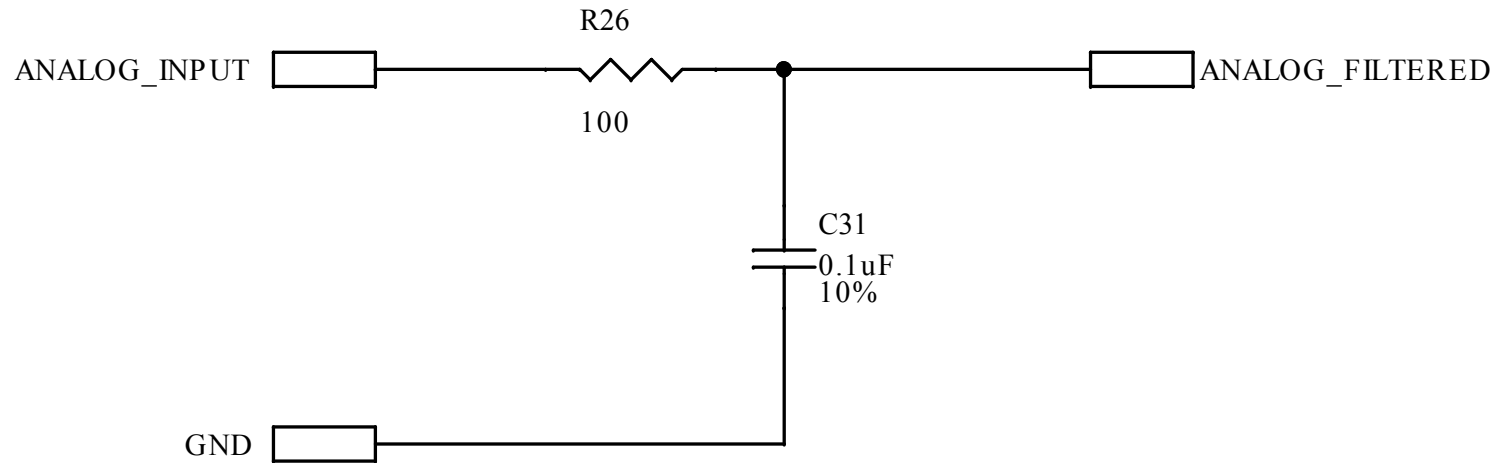

Figure 21. STEVAL-CTM020A circuit schematic (16 of 26)
RC filter close to MCU pin

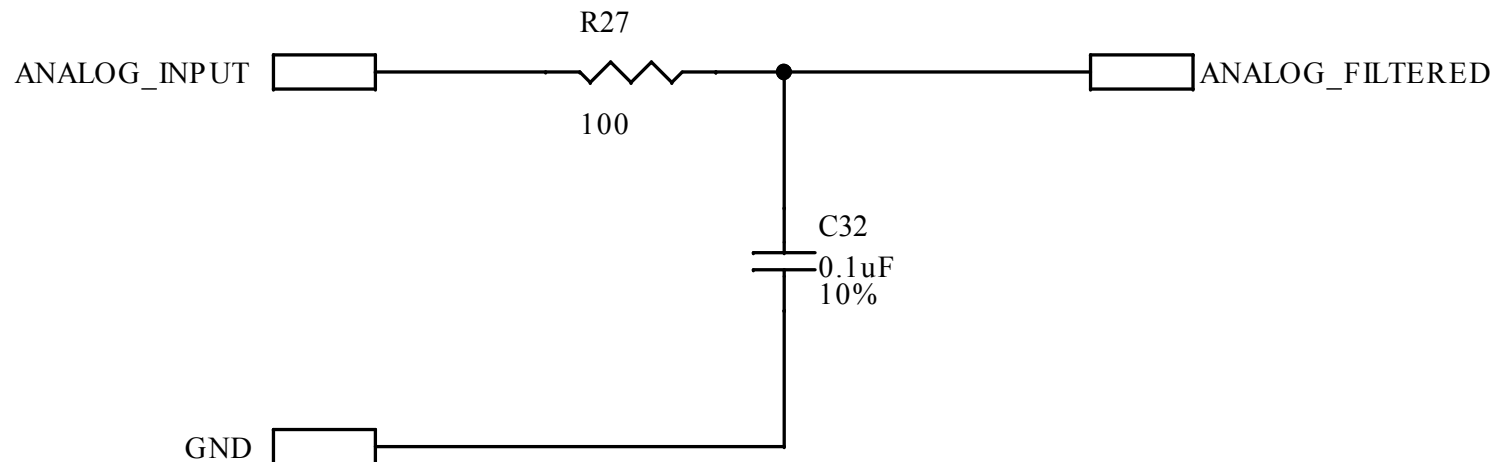

Figure 22. STEVAL-CTM020A circuit schematic (17 of 26)
RC filter close to MCU pin

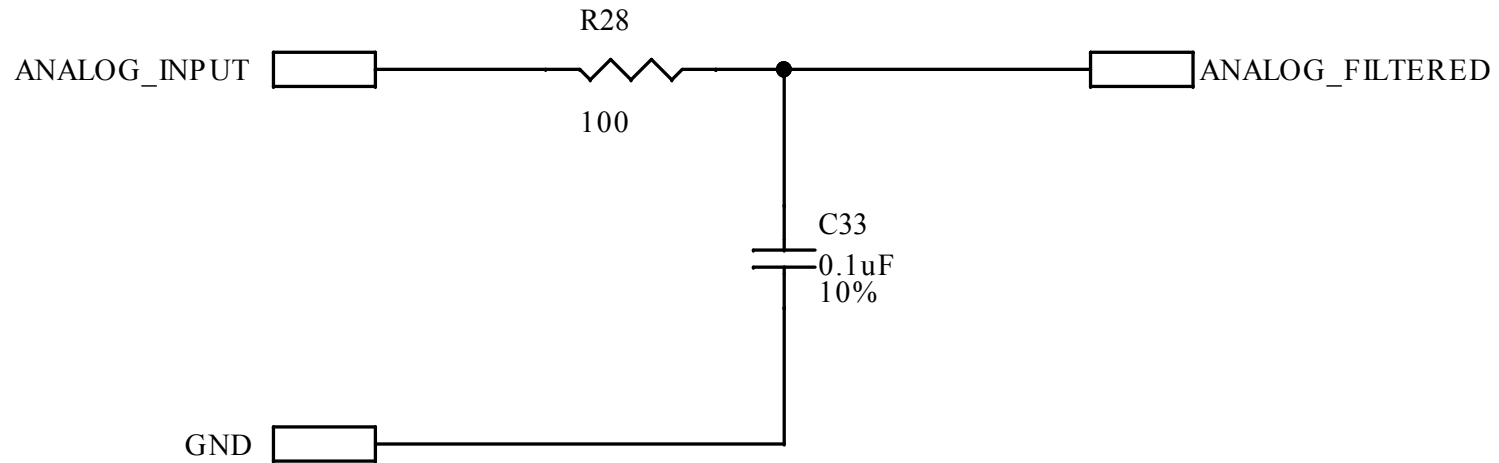

Figure 23. STEVAL-CTM020A circuit schematic (18 of 26)
RC filter close to MCU pin

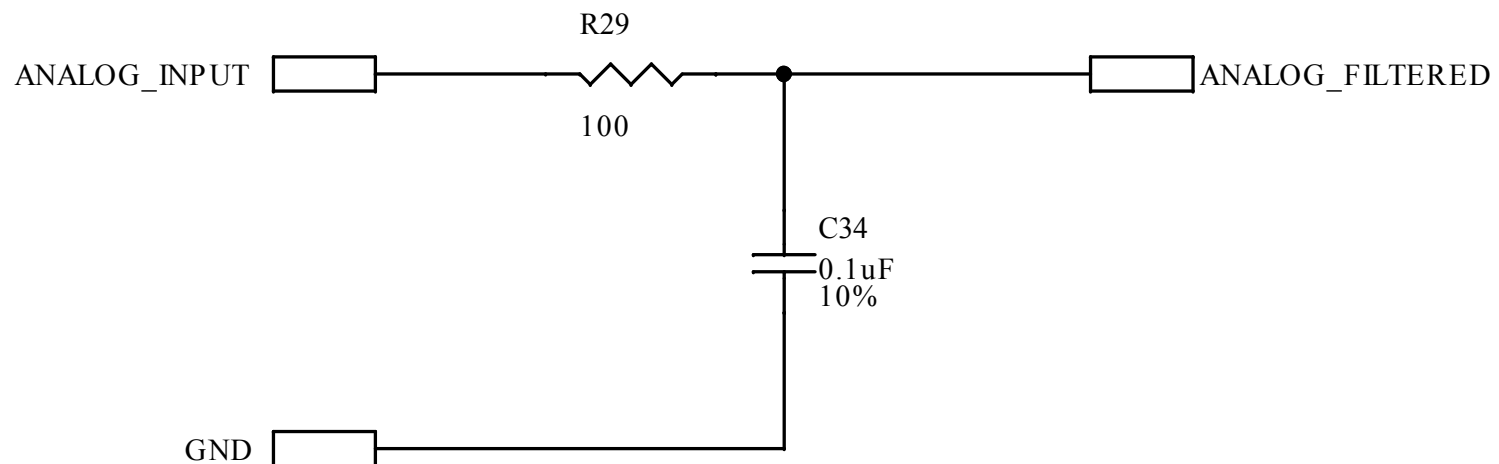

Figure 24. STEVAL-CTM020A circuit schematic (19 of 26)
RC filter close to MCU pin

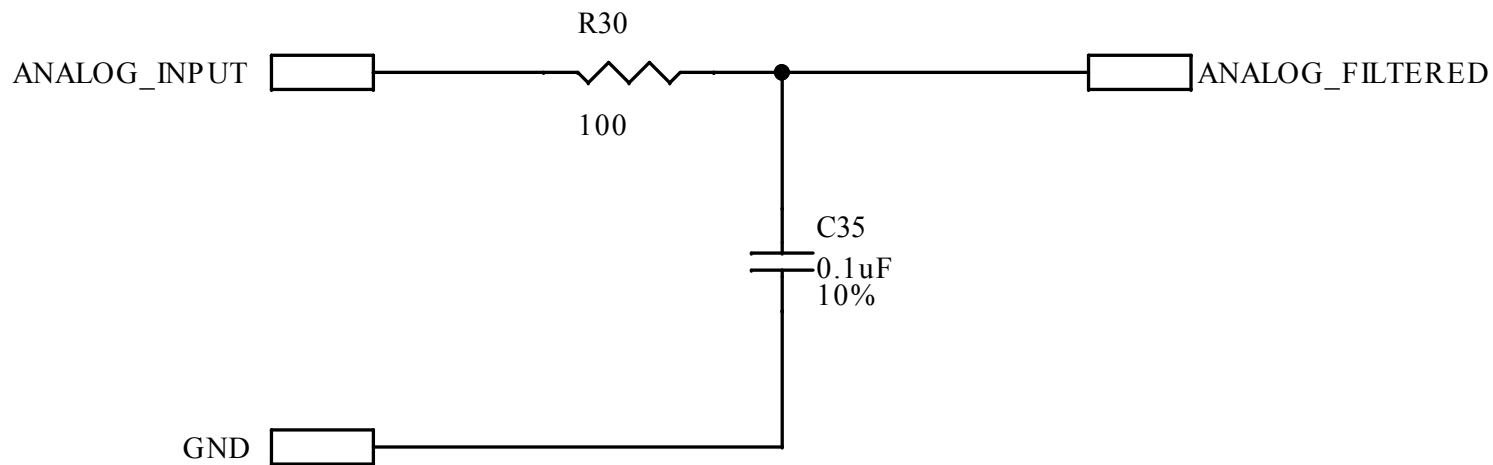

Figure 25. STEVAL-CTM020A circuit schematic (20 of 26)
RC filter close to MCU pin

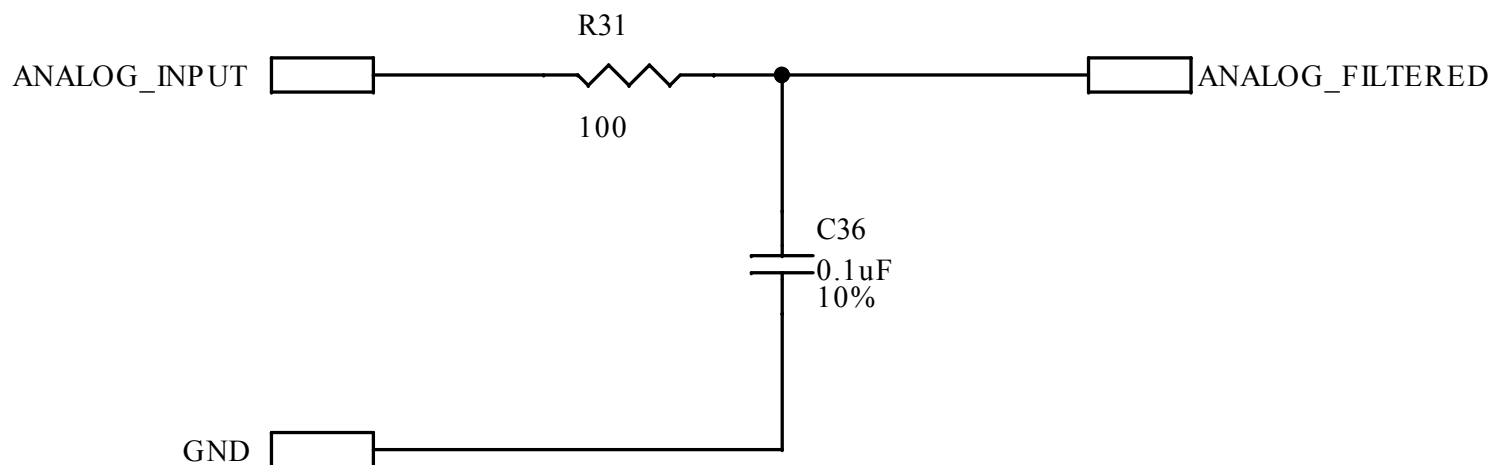

Figure 26. STEVAL-CTM020A circuit schematic (21 of 26)
RC filter close to MCU pin

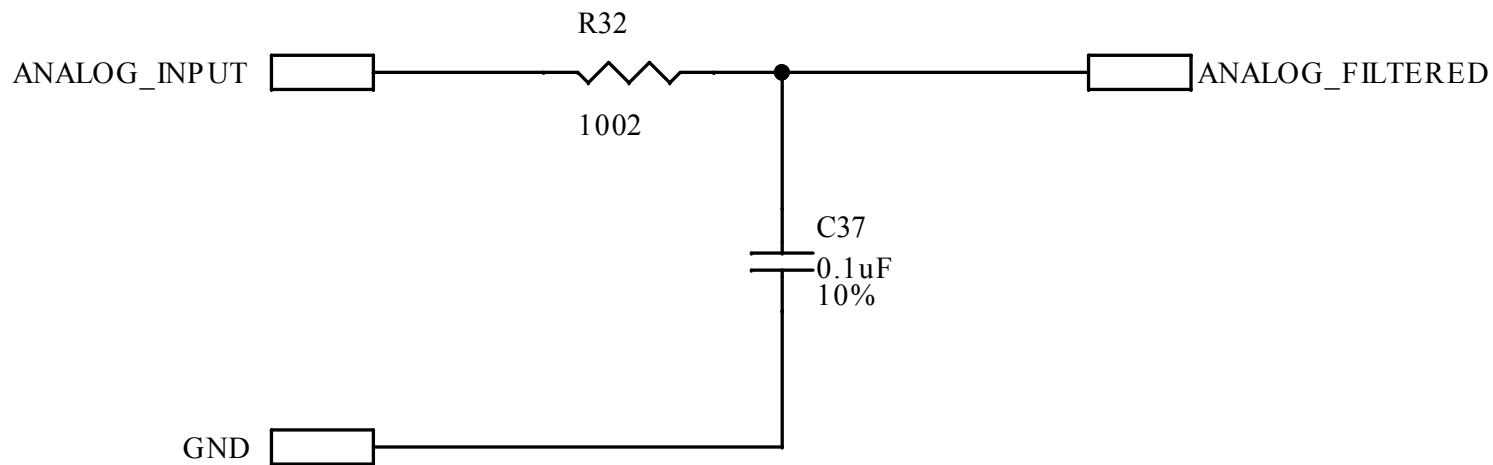

Figure 27. STEVAL-CTM020A circuit schematic (22 of 26)
RC filter close to MCU pin

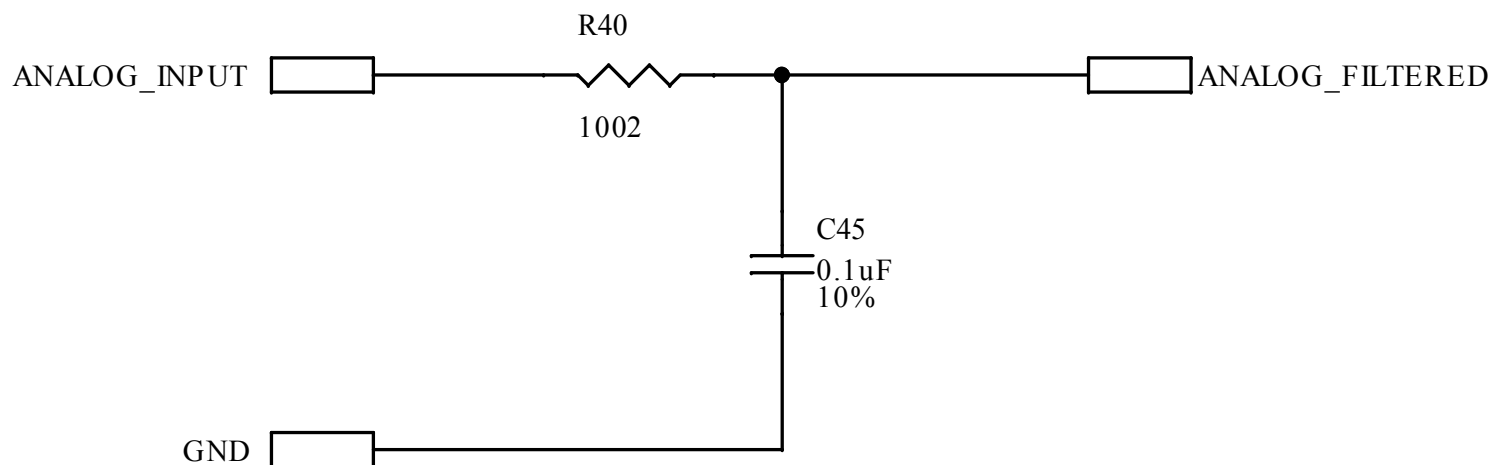

Figure 28. STEVAL-CTM020A circuit schematic (23 of 26)
RC filter close to MCU pin

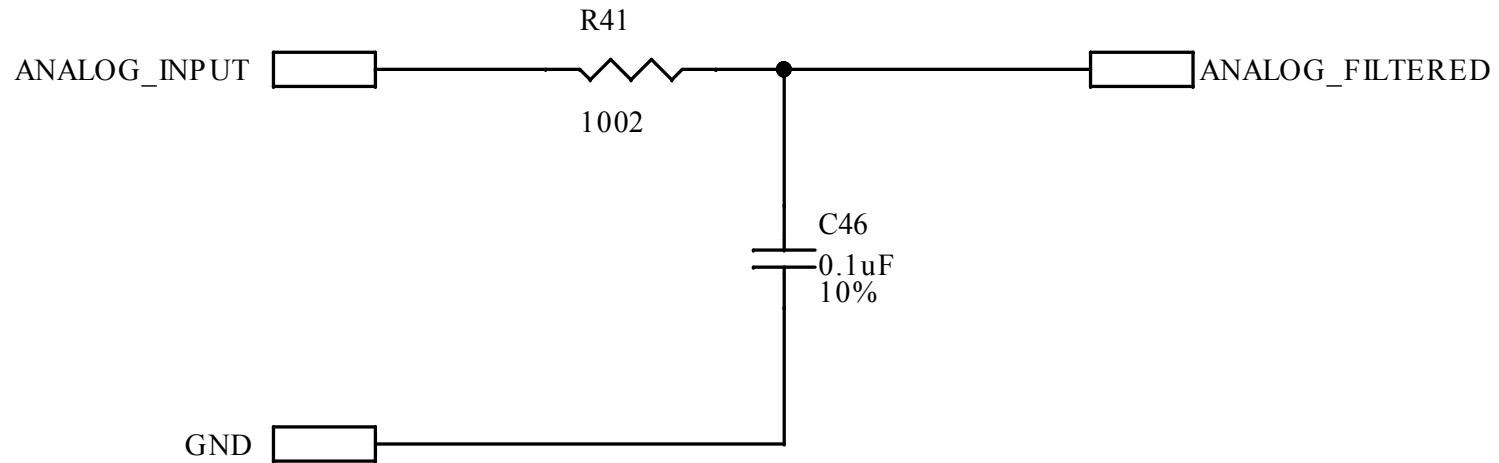

Figure 29. STEVAL-CTM020A circuit schematic (24 of 26)
RC filter close to MCU pin

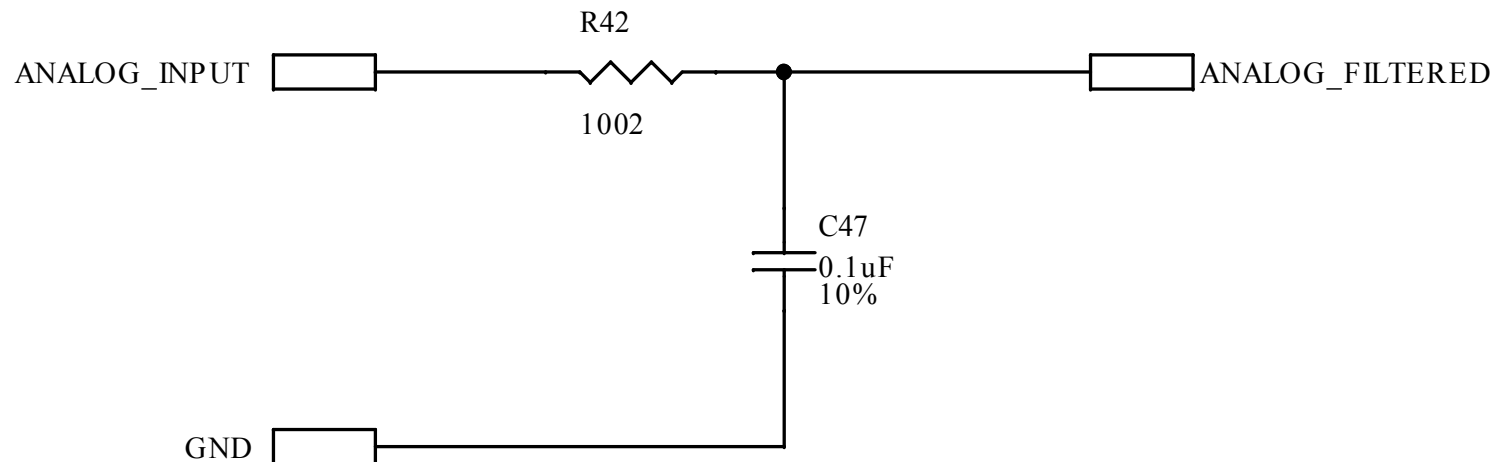

Figure 30. STEVAL-CTM020A circuit schematic (25 of 26)
RC filter close to MCU pin

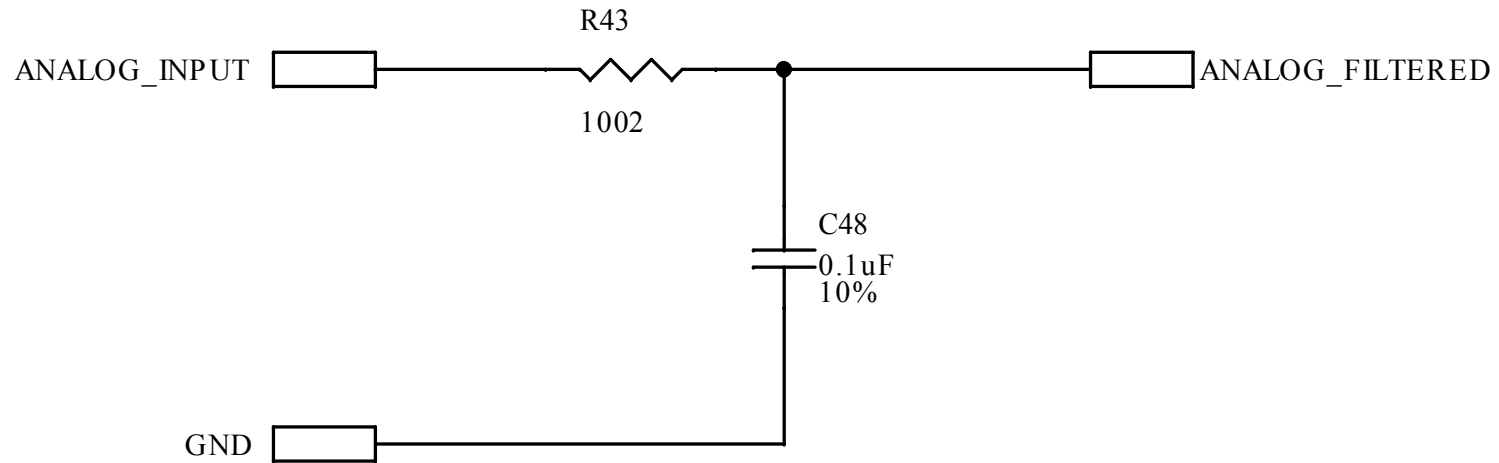
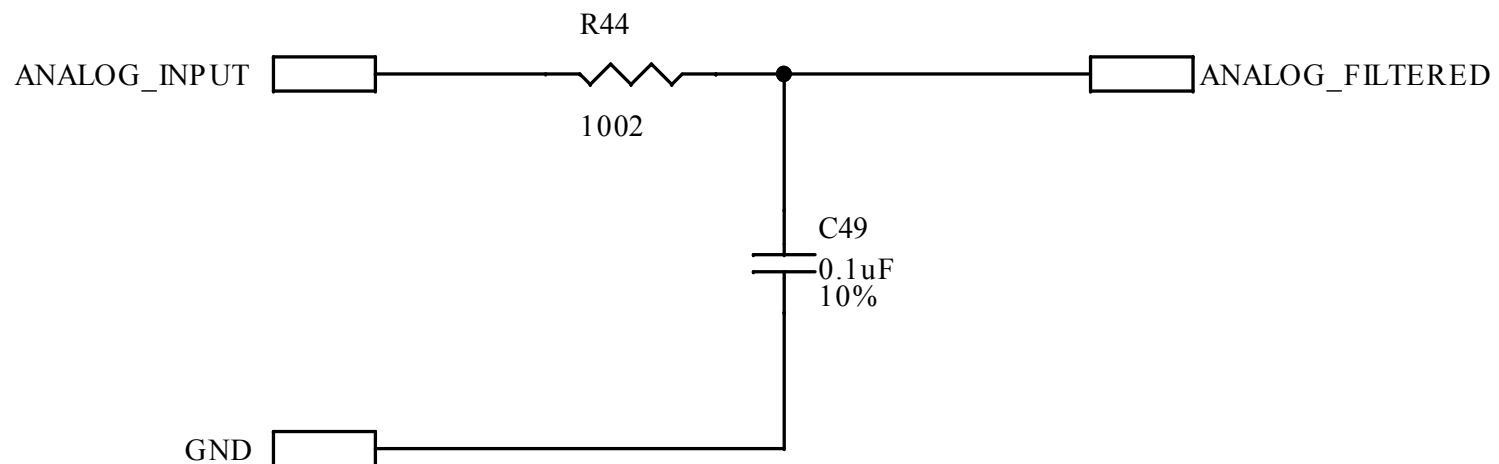

Figure 31. STEVAL-CTM020A circuit schematic (26 of 26)
RC filter close to MCU pin



13 Bill of materials
Table 5. STEVAL-CTM020A bill of materials

Item	Q.ty	Ref.	Part/Value	Description	Manufacturer	Order code
1	2	C1 C2	1.8pF	CAP CER 1.8PF 50V C0G/NP0 0402	Wurth Electronics Inc.	885392005008
2	34	C3 C8 C9 C10 C11 C12 C13 C14 C15 C17 C21 C22 C23 C24 C25 C26 C27 C28 C29 C30 C31 C32 C33 C34 C35 C36 C37 C45 C46 C47 C48 C49 C51 C53	0.1uF	CAP CER 0.1UF 16V X7R 0402	Wurth Electronics Inc.	885012205037
3	4	C4 C5 C6 C7	1nF	CAP CER 1000PF 16V X7R 0402	Wurth Electronics Inc.	885012205025
4	1	C16	4.7uF	CAP CER 4.7UF 10V X5R 0402	Murata Electronics North America	GRM155R61A475MEAA D
5	1	C18	10uF	CAP CER 10UF 10V X5R 0402	Samsung Electro- Mechanics America, Inc.	CL05A106MP8NUB8
6	2	C50, C52	1uF	CAP CER 1UF 10V X5R 0402	Wurth Electronics Inc.	885012105012
7	1	C54, C55	33pF	CAP CER 33PF 10V C0G/NP0 0402	Wurth Electronics Inc.	885012005010
8	1	CN1	Con14-male	CONN HEADER SMD 14POS 1.27MM	Samtec Inc.	FTSH-107-01-F-DV-K-P- TR
9	1	D1	LED GREEN	LED GREEN CLEAR 0603 SMD	Wurth Electronics Inc.	150060GS75000
10	1	D2	RED LED	LED RED CLEAR 0603 SMD	Wurth Electronics Inc.	150060RS75000
11	1	D3	ESDZL5-1F4, ST0201	TVS DIODE 3VWM ST0201	ST	ESDZL5-1F4
12	1	J10	PCIE-164-PLUG	CON 164 PCI EXPRESS - PCB PLUG (not assembled)	/	/
13	1	J2	GND	CONN HEADER SMD 2POS 2.54MM	Samtec Inc.	TSM-102-01-L-SV

Item	Q.ty	Ref.	Part/Value	Description	Manufacturer	Order code
14	1	J3	EXT. 5V	CONN HEADER SMD 2POS 2.54MM	Samtec Inc.	TSM-102-01-L-SV
15	1	J9	con2-strip-male- SMD	CONN HEADER SMD 2POS 2.54MM	Samtec Inc.	TSM-102-01-L-SV
16	1	L1	600Ohm@100MHz	FERRITE BEAD 600 OHM 0603 1LN	Würth Electronics Inc.	742863160
17	1	R1	0.0	RES SMD 0.0OHM JUMPER 1/10W 0603	Yageo	RC0603JR-070RL
18	1	R2	0.0	RES SMD 0.0OHM JUMPER 1/10W 0603	Yageo	RC0603JR-070RL
19	2	R3 R4	47k	RES 47K OHM 1% 1/10W 0402	Würth Electronics Inc.	560112110055
20	1	R5	10K	RES SMD 10K OHM 1% 1/16W 0402 (not assembled)	TE Connectivity Passive Product	CRG0402F10K
21	2	R6 R7	510	RES 510 OHM 1% 1/16W 0402	Yageo	RC0402FR-07510RL
22	4	R8 R10 R12 R14	1k	RES 1K OHM 1% 1/10W 0402	Würth Electronics Inc.	560112110012
23	4	R9 R11 R13 R15	3.3k	RES 3.3K OHM 5% 1/10W 0402	Würth Electronics Inc.	560112110053
24	22	R16 R17 R18 R19 R20 R21 R22 R23 R24 R25 R26 R27 R28 R29 R30 R31 R32 R40 R41 R42 R43 R44	100	RES 100 OHM 1% 1/10W 0402	Würth Electronics Inc.	560112110022
25	2	R47 R48	1k	CHIP RESISTOR SMD 1% 1/16W 0402	Würth Electronics Inc.	560112110012
26	1	SW1	1437566-3	SWITCH TACTILE SPST-NO 0.05A 24V	TE Connectivity ALCOSWITCH Switches	1437566-3
27	1	TP1	DAC_CH1	PC TEST POINT NATURAL	Harwin Inc.	S1751-46R
28	1	TP2	DAC_CH2	PC TEST POINT NATURAL	Harwin Inc.	S1751-46R

Item	Q.ty	Ref.	Part/Value	Description	Manufacturer	Order code
29	1	TP3	VDD	TEST POINT 1MM SMD PADSTASCK (not assembled)	/	/
30	1	TP4	VDDA / VREF	TEST POINT 1MM SMD PADSTASCK (not assembled)	/	/
31	1	TP5	GND	TEST POINT 1MM SMD PADSTASCK (not assembled)	/	/
32	1	U1	STM32G474QBT6, LQFP 128	IC MCU 32BIT 128KB FLASH 128LQFP	ST	STM32G474QBT6
33	1	U2	LD39050PU33R, DFN6 3x3	IC REG LINEAR 3.3V 500MA 6DFN	ST	LD39050PU33R
34	1	Y1	24MHz	CRYSTAL 24.00 MHZ 9.0PF SMD	EPSON	TSX-3225 24.0000MF15X-AC6
35	1	PCB No Reference	6 Layer FR4 PCB	FR4-Tg140- copper Thickness int/ exter layer 35micron Final finishes Electrolytic Hard Gold	/	/

14 Board versions

Table 6. STEVAL-CTM020A versions

Finished good	Schematic diagrams	Bill of materials
STV\$CTM020AA ⁽¹⁾	STV\$CTM020AA schematic diagrams	STV\$CTM020AA bill of materials

1. This code identifies the STEVAL-CTM020A evaluation board first version.

15 Regulatory compliance information

Notice for US Federal Communication Commission (FCC)

For evaluation only; not FCC approved for resale

FCC NOTICE - This kit is designed to allow:

(1) Product developers to evaluate electronic components, circuitry, or software associated with the kit to determine

whether to incorporate such items in a finished product and

(2) Software developers to write software applications for use with the end product.

This kit is not a finished product and when assembled may not be resold or otherwise marketed unless all required FCC equipment authorizations are first obtained. Operation is subject to the condition that this product not cause harmful interference to licensed radio stations and that this product accept harmful interference. Unless the assembled kit is designed to operate under part 15, part 18 or part 95 of this chapter, the operator of the kit must operate under the authority of an FCC license holder or must secure an experimental authorization under part 5 of this chapter 3.1.2.

Notice for Innovation, Science and Economic Development Canada (ISED)

For evaluation purposes only. This kit generates, uses, and can radiate radio frequency energy and has not been tested for compliance with the limits of computing devices pursuant to Industry Canada (IC) rules.

À des fins d'évaluation uniquement. Ce kit génère, utilise et peut émettre de l'énergie radiofréquence et n'a pas été testé pour sa conformité aux limites des appareils informatiques conformément aux règles d'Industrie Canada (IC).

Notice for the European Union

This device is in conformity with the essential requirements of the Directive 2014/30/EU (EMC) and of the Directive 2011/65/EU (RoHS II), including subsequent revisions and additions, as well as amended by the Delegated Directive 2015/863/EU (RoHS III).

Notice for the United Kingdom

This device is in conformity with the relevant provisions of the following EU legislation recognized by the United Kingdom:

- Electromagnetic Compatibility Regulations 2016 (S.I. 2016/1091) implementing Directive 2014/30/EU (EMC)
- The Restriction of the Use of Certain Hazardous Substances in Electrical and Electronic Equipment Regulations 2012 (RoHS) (S.I. 2012/3032) implementing Directive 2011/65/EU (RoHS II), including subsequent revisions and additions, as well as amended by the Delegated Directive 2015/863/EU (RoHS III).

Revision history

Table 7. Document revision history

Date	Revision	Changes
27-Mar-2026	1	Initial release.

Contents

1	Features	2
2	Ordering information	3
3	Development environment	4
4	Quick start	5
5	Hardware layout and configuration	6
6	External debugging tool	7
6.1	Description	7
6.2	Drivers	7
6.3	Use of an external debugging tool to program and debug the on-board STM32.....	7
7	Debug/communication connector (CN1)	8
8	MC connector V2	10
9	DAC-based debug functionality	16
10	Power supply options and configuration	17
11	Using STEVAL-CTM020A with the STM32 Motor Control SDK (X-CUBE-MCSDK) ...	18
12	Schematic diagrams	19
13	Bill of materials	34
14	Board versions	37
15	Regulatory compliance information	38
	Revision history	39
	List of tables	41
	List of figures	42

List of tables

Table 1.	List of available products	3
Table 2.	CN1 debug / communication connector pinout	9
Table 3.	MC connector V2	10
Table 4.	Power supply configuration options	17
Table 5.	STEVAL-CTM020A bill of materials	34
Table 6.	STEVAL-CTM020A versions	37
Table 7.	Document revision history	39

List of figures

Figure 1.	STEVAL-CTM020A	1
Figure 2.	Hardware block diagram	6
Figure 3.	STEVAL-CTM020A PCB layout (top view)	6
Figure 4.	CN1 debug/communication connector pinout	8
Figure 5.	TP1-TP2 DAC-based debug functionality	16
Figure 6.	STEVAL-CTM020A circuit schematic (1 of 26)	19
Figure 7.	STEVAL-CTM020A circuit schematic (2 of 26)	20
Figure 8.	STEVAL-CTM020A circuit schematic (3 of 26)	21
Figure 9.	STEVAL-CTM020A circuit schematic (4 of 26)	22
Figure 10.	STEVAL-CTM020A circuit schematic (5 of 26)	23
Figure 11.	STEVAL-CTM020A circuit schematic (6 of 26)	23
Figure 12.	STEVAL-CTM020A circuit schematic (7 of 26)	24
Figure 13.	STEVAL-CTM020A circuit schematic (8 of 26)	24
Figure 14.	STEVAL-CTM020A circuit schematic (9 of 26)	25
Figure 15.	STEVAL-CTM020A circuit schematic (10 of 26)	25
Figure 16.	STEVAL-CTM020A circuit schematic (11 of 26)	26
Figure 17.	STEVAL-CTM020A circuit schematic (12 of 26)	26
Figure 18.	STEVAL-CTM020A circuit schematic (13 of 26)	27
Figure 19.	STEVAL-CTM020A circuit schematic (14 of 26)	27
Figure 20.	STEVAL-CTM020A circuit schematic (15 of 26)	28
Figure 21.	STEVAL-CTM020A circuit schematic (16 of 26)	28
Figure 22.	STEVAL-CTM020A circuit schematic (17 of 26)	29
Figure 23.	STEVAL-CTM020A circuit schematic (18 of 26)	29
Figure 24.	STEVAL-CTM020A circuit schematic (19 of 26)	30
Figure 25.	STEVAL-CTM020A circuit schematic (20 of 26)	30
Figure 26.	STEVAL-CTM020A circuit schematic (21 of 26)	31
Figure 27.	STEVAL-CTM020A circuit schematic (22 of 26)	31
Figure 28.	STEVAL-CTM020A circuit schematic (23 of 26)	32
Figure 29.	STEVAL-CTM020A circuit schematic (24 of 26)	32
Figure 30.	STEVAL-CTM020A circuit schematic (25 of 26)	33
Figure 31.	STEVAL-CTM020A circuit schematic (26 of 26)	33

IMPORTANT NOTICE – READ CAREFULLY

STMicroelectronics NV and its subsidiaries (“ST”) reserve the right to make changes, corrections, enhancements, modifications, and improvements to ST products and/or to this document at any time without notice.

In the event of any conflict between the provisions of this document and the provisions of any contractual arrangement in force between the purchasers and ST, the provisions of such contractual arrangement shall prevail.

The purchasers should obtain the latest relevant information on ST products before placing orders. ST products are sold pursuant to ST’s terms and conditions of sale in place at the time of order acknowledgment.

The purchasers are solely responsible for the choice, selection, and use of ST products and ST assumes no liability for application assistance or the design of the purchasers’ products.

No license, express or implied, to any intellectual property right is granted by ST herein.

Resale of ST products with provisions different from the information set forth herein shall void any warranty granted by ST for such product.

If the purchasers identify an ST product that meets their functional and performance requirements but that is not designated for the purchasers’ market segment, the purchasers shall contact ST for more information.

ST and the ST logo are trademarks of ST. For additional information about ST trademarks, refer to www.st.com/trademarks. All other product or service names are the property of their respective owners.

Information in this document supersedes and replaces information previously supplied in any prior versions of this document.

© 2026 STMicroelectronics – All rights reserved