

Automotive N-channel logic level 40 V, 0.59 mΩ max., 420 A Smart STripFET F8 Power MOSFET in a PowerFLAT 5x6 package

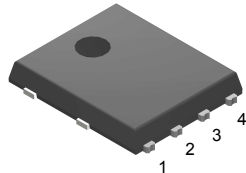

PowerFLAT 5x6

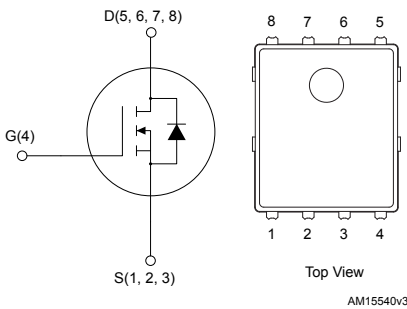

Features

Order code	V _{DS}	R _{DS(on)} max.	I _D
STL059N4S8AG	40 V	0.59 mΩ	420 A

- AEC-Q101 qualified 
- MSL1 grade
- 175 °C operating temperature
- 100% avalanche tested
- Wettable flank package
- Extremely low R_{DS(on)}
- Logic level

Applications

- Power distribution

Description

The **STL059N4S8AG** is a 40 V N-channel enhancement mode Power MOSFET designed in Smart STripFET F8, the new dedicated STripFET F8 based technology aimed for Power distribution applications, featuring an enhanced trench gate structure.

The Smart STripFET F8 ensures an extremely low on state resistance, which makes it excellent, in combination with ST²Fuse gate drivers, for high current Power distribution units.



Product status link

[STL059N4S8AG](#)

Product summary

Order code	STL059N4S8AG
Marking	059N4S8
Package	PowerFLAT 5x6
Packing	Tape and reel

1 Electrical ratings

Table 1. Absolute maximum ratings (at $T_C = 25\text{ °C}$ unless otherwise specified)

Symbol	Parameter	Value	Unit
V_{DS}	Drain-source voltage	40	V
V_{GS}	Gate-source voltage	± 20	V
$I_D^{(1)}$	Drain current (continuous) at $T_C = 25\text{ °C}^{(2)}$	420	A
	Drain current (continuous) at $T_C = 100\text{ °C}^{(2)}$	297	
	Drain current (continuous) at $T_C = 25\text{ °C}^{(3)}$	120	
$I_{DM}^{(1)(2)(4)}$	Drain current (pulsed), $t_p = 10\text{ }\mu\text{s}$	1680	A
P_{TOT}	Total power dissipation at $T_C = 25\text{ °C}$	187	W
I_{AS}	Single pulse avalanche current (pulse width limited by T_J max.)	60	A
E_{AS}	Single pulse avalanche energy (starting $T_J = 25\text{ °C}$, $I_D = 60\text{ A}$, $R_{Gmin} = 25\text{ }\Omega$)	603	mJ
T_J	Operating junction temperature range	-55 to 175	$^{\circ}\text{C}$
T_{stg}	Storage temperature range		$^{\circ}\text{C}$

1. Specified by design, not tested in production.
2. This is the theoretical current value only related to the silicon.
3. This current value is limited by package.
4. Pulse width is limited by safe operating area.

Table 2. Thermal data

Symbol	Parameter	Value	Unit
$R_{thJA}^{(1)}$	Thermal resistance, junction-to-ambient (on 2s2p FR-4 board vertical in still area)	15	$^{\circ}\text{C/W}$
R_{thJC}	Thermal resistance, junction-to-case	0.8	$^{\circ}\text{C/W}$

1. Defined according to JEDEC standards (JESD51-5, -7).

2 Electrical characteristics

$T_J = 25\text{ °C}$ unless otherwise specified.

Table 3. On/off states

Symbol	Parameter	Test conditions	Min.	Typ.	Max.	Unit
$V_{(BR)DSS}$	Drain-source breakdown voltage	$V_{GS} = 0\text{ V}, I_D = 1\text{ mA}$	40			V
I_{DSS}	Zero gate voltage drain current	$V_{DS} = 40\text{ V}, V_{GS} = 0\text{ V}$			1	μA
		$V_{DS} = 40\text{ V}, V_{GS} = 0\text{ V}, T_J = 125\text{ °C}^{(1)}$			100	
I_{GSS}	Gate-body leakage current	$V_{GS} = 20\text{ V}, V_{DS} = 0\text{ V}$			100	nA
$V_{GS(th)}$	Gate threshold voltage	$V_{DS} = V_{GS}, I_D = 250\text{ }\mu\text{A}$	1.2		2.0	V
$R_{DS(on)}$	Static drain-source on-resistance	$V_{GS} = 10\text{ V}, I_D = 60\text{ A}$		0.45	0.59	m Ω
		$V_{GS} = 4.5\text{ V}, I_D = 60\text{ A}$		0.65	0.85	

1. Specified by design and evaluated by characterization, not tested in production.

Table 4. Dynamic

Symbol	Parameter	Test conditions	Min.	Typ.	Max.	Unit
$C_{iss}^{(1)}$	Input capacitance	$V_{DS} = 25\text{ V}, f = 1\text{ MHz}, V_{GS} = 0\text{ V}$	-	11000	-	pF
$C_{oss}^{(1)}$	Output capacitance		-	2200	-	pF
$C_{riss}^{(1)}$	Reverse transfer capacitance		-	2100	-	pF
$Q_g^{(1)}$	Total gate charge	$V_{DD} = 20\text{ V}, I_D = 120\text{ A}, V_{GS} = 4.5\text{ V}$	-	170	-	nC
		$V_{DD} = 20\text{ V}, I_D = 120\text{ A}, V_{GS} = 10\text{ V}$	-	275	-	
$Q_{gs}^{(1)}$	Gate-source charge	$V_{DD} = 20\text{ V}, I_D = 120\text{ A}$	-	35	-	nC
$Q_{gd}^{(1)}$	Gate-drain charge		-	110	-	nC

1. Specified by design and evaluated by characterization, not tested in production.

Table 5. Switching times

Symbol	Parameter	Test conditions	Min.	Typ.	Max.	Unit
$t_{d(on)}^{(1)}$	Turn-on delay time	$V_{DD} = 20\text{ V}, I_D = 60\text{ A},$ $R_G = 4.7\text{ }\Omega, V_{GS} = 10\text{ V}$	-	24	-	ns
$t_r^{(1)}$	Rise time		-	67	-	ns
$t_{d(off)}^{(1)}$	Turn-off delay time		-	165	-	ns
$t_f^{(1)}$	Fall time		-	223	-	ns

1. Specified by design and evaluated by characterization, not tested in production.

Table 6. Source-drain diode

Symbol	Parameter	Test conditions	Min.	Typ.	Max.	Unit
$I_{SD}^{(1)(2)}$	Forward on current (continuous)	$T_C = 25\text{ °C}$	-		125	A
V_{SD}	Forward on voltage	$I_{SD} = 60\text{ A}, V_{GS} = 0\text{ V}$	-		1.1	V
$t_{rr}^{(1)}$	Reverse recovery time	$I_D = 60\text{ A}, di/dt = 100\text{ A}/\mu\text{s}, V_{DD} = 32\text{ V}$	-	75		ns
$Q_{rr}^{(1)}$	Reverse recovery charge		-	95		nC
$I_{RRM}^{(1)}$	Reverse recovery current		-	2.6		A

1. Specified by design and evaluated by characterization, not tested in production.
2. This is the theoretical current value only related to the silicon.

2.1 Electrical characteristics (curves)

Figure 1. Total power dissipation

Figure 2. Drain current vs case temperature

Figure 3. Typical output characteristics

Figure 4. Typical transfer characteristics

Figure 5. Safe operating area

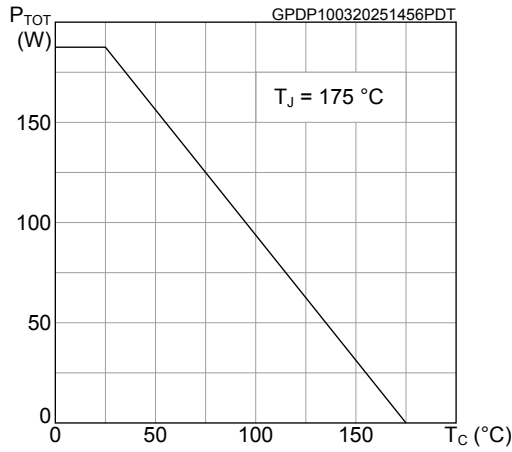
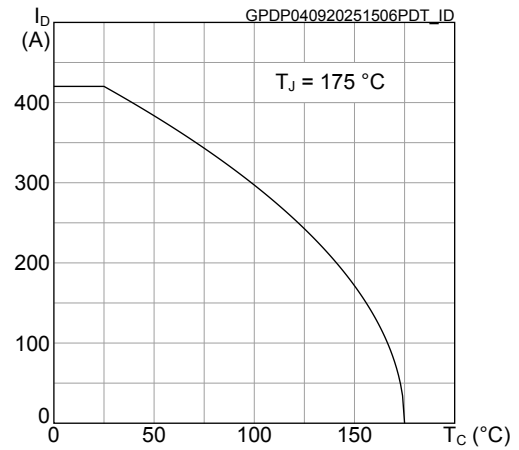
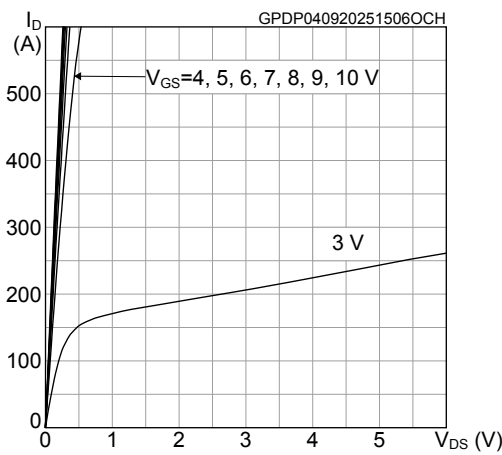
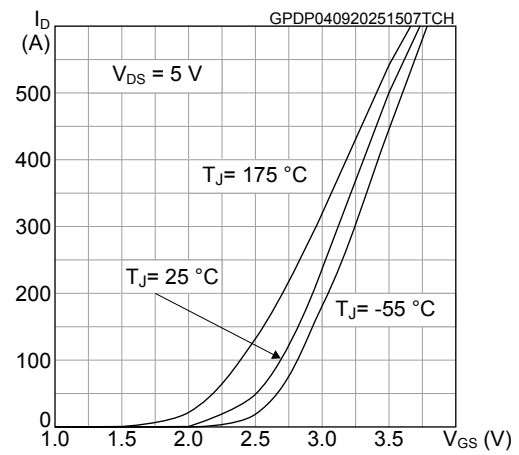
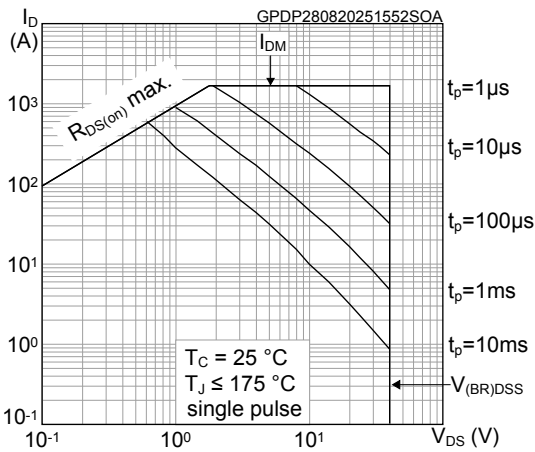
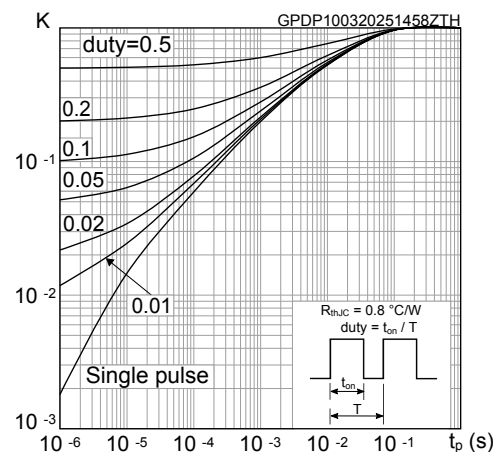
Figure 6. Normalized transient thermal impedance

Figure 7. Typical gate charge characteristics

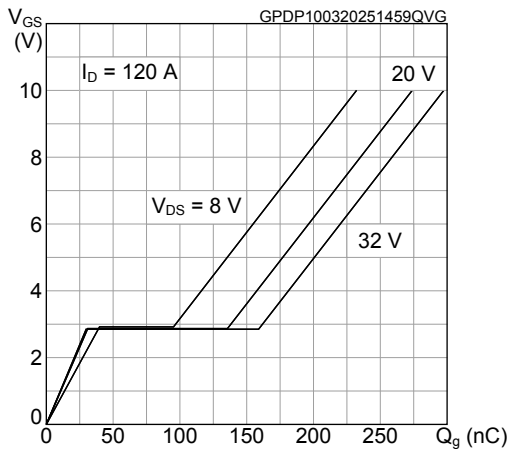

Figure 8. Typical capacitance characteristics

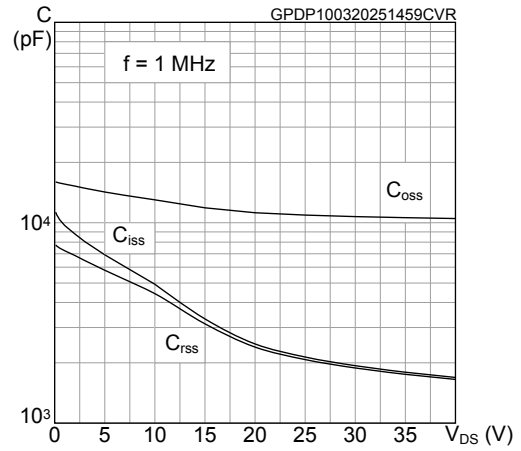

Figure 9. Avalanche characteristics

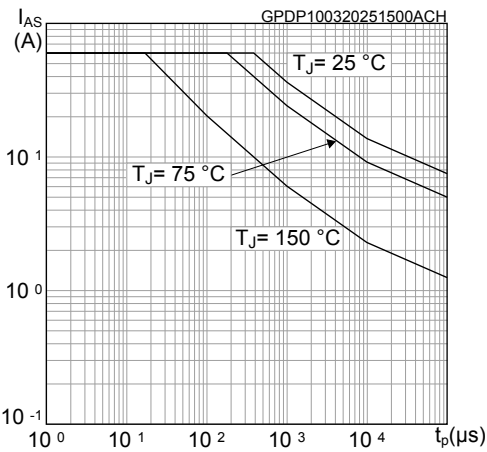

Figure 10. Avalanche energy

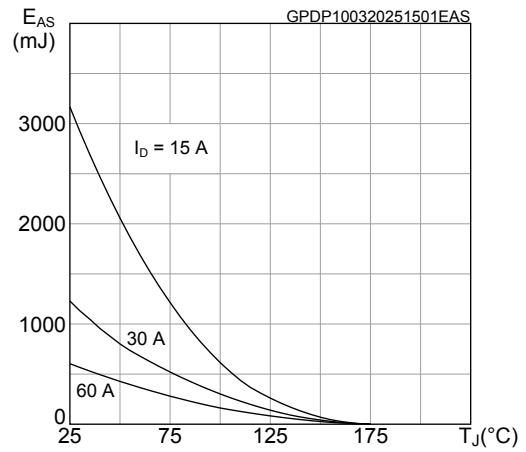

Figure 11. Typical drain-source on-resistance

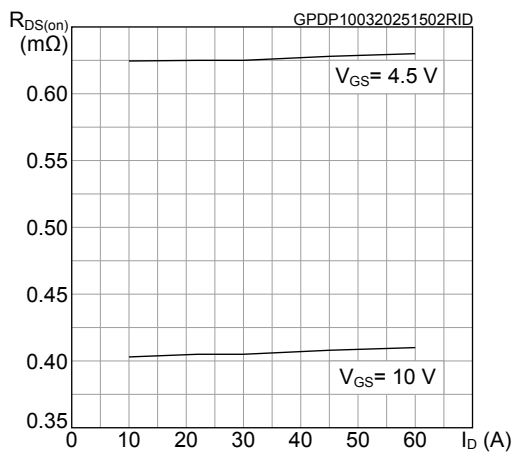

Figure 12. Typical on-resistance vs gate-source voltage

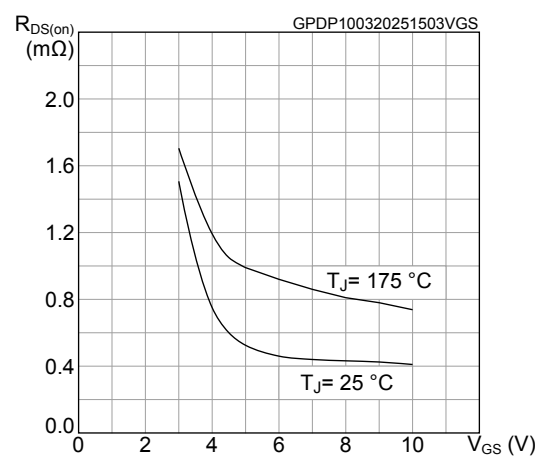

Figure 13. Normalized on-resistance vs temperature

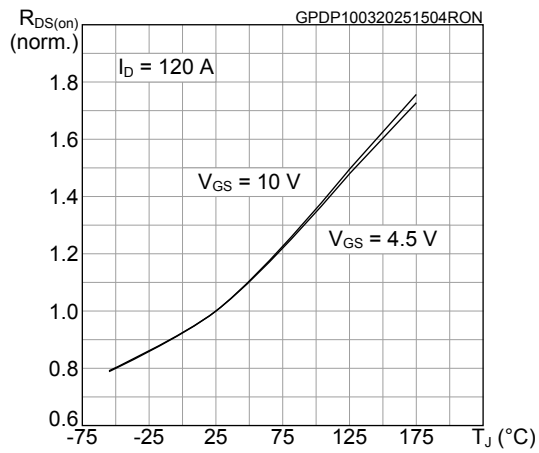

Figure 14. Normalized gate threshold voltage vs temperature

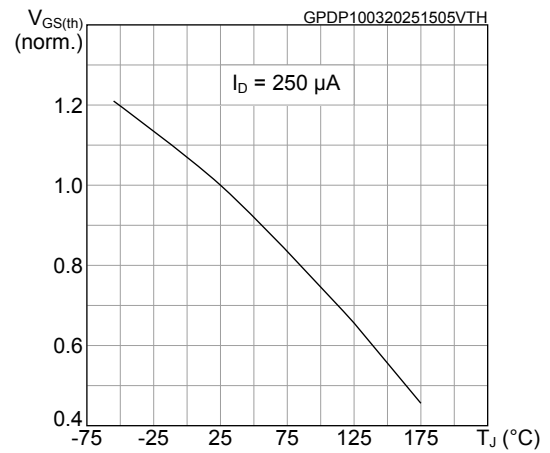

Figure 15. Typical reverse diode forward characteristics

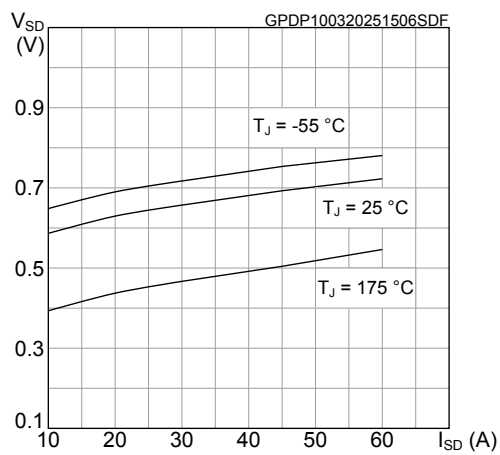
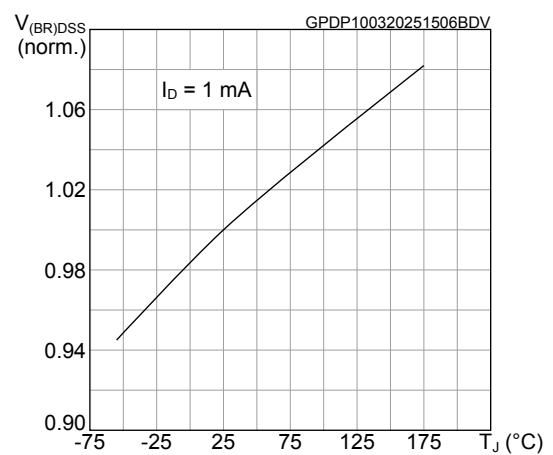

Figure 16. Normalized $V_{(BR)DSS}$ vs temperature



3 Package information

To meet environmental requirements, ST offers these devices in different grades of **ECOPACK** packages, depending on their level of environmental compliance. ECOPACK specifications, grade definitions, and product status are available at: www.st.com. ECOPACK is an ST trademark.

3.1 PowerFLAT 5x6 WF type C package information

Figure 17. PowerFLAT 5x6 WF type C package outline

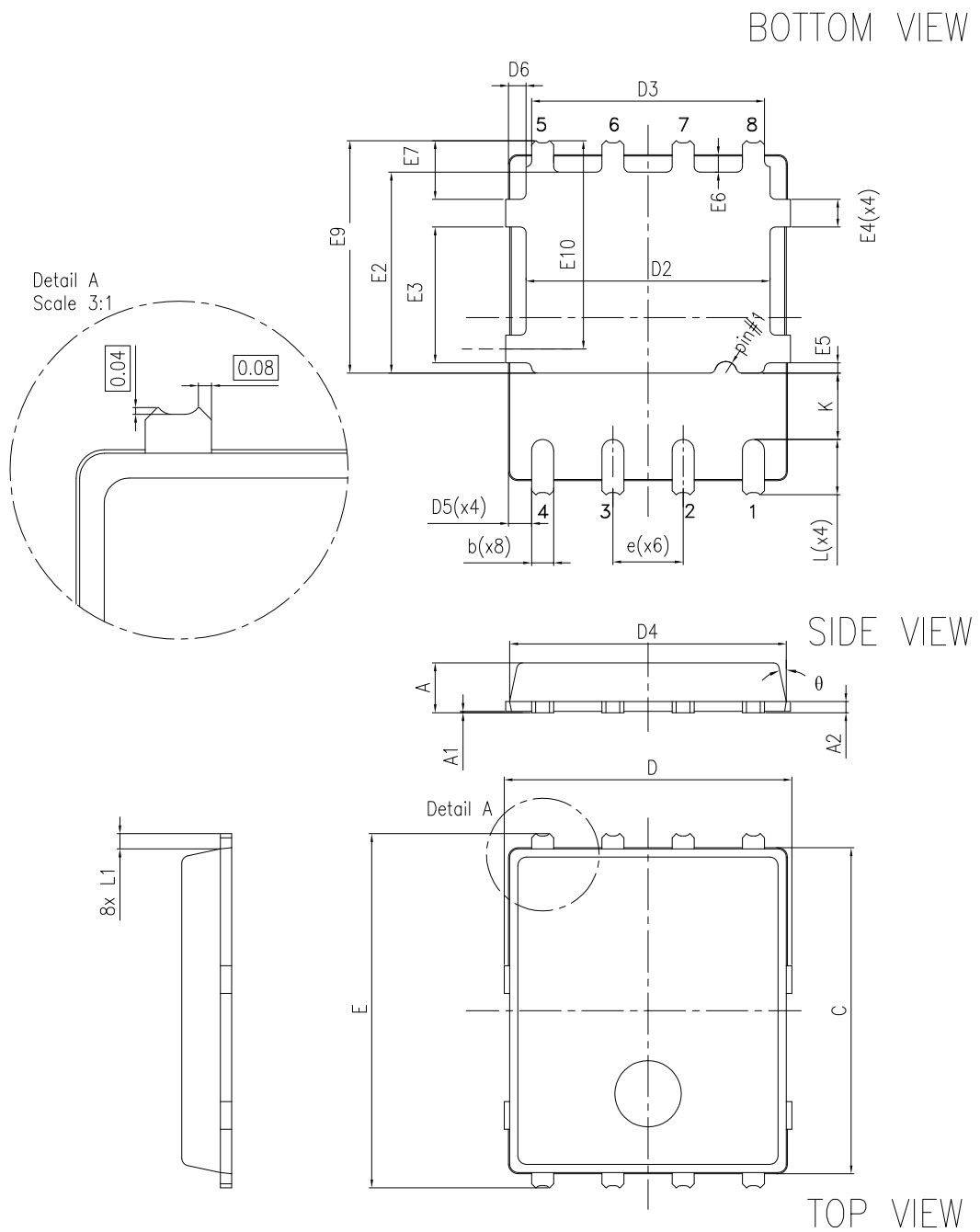

8231817_WF_typeC_r24

Table 7. PowerFLAT 5x6 WF type C mechanical data

Dim.	mm		
	Min.	Typ.	Max.
A	0.80		1.00
A1	0.00		0.05
A2	0.20	0.25	0.30
b	0.30		0.50
C	5.80	6.00	6.10
D	5.00	5.20	5.40
D2	4.15		4.45
D3	4.05	4.20	4.35
D4	4.80	5.00	5.10
D5	0.25	0.40	0.55
D6	0.15	0.30	0.45
e		1.27	
E	6.20	6.40	6.60
E2	3.50		3.70
E3	2.35		2.55
E4	0.40		0.60
E5	0.08		0.28
E6	0.20	0.325	0.45
E7	0.85	1.00	1.15
E9	4.00	4.20	4.40
E10	3.55	3.70	3.85
K	1.05		1.35
L	0.90	1.00	1.10
L1	0.175	0.275	0.375
θ	0°		12°

Figure 18. PowerFLAT 5x6 recommended footprint (dimensions are in mm)

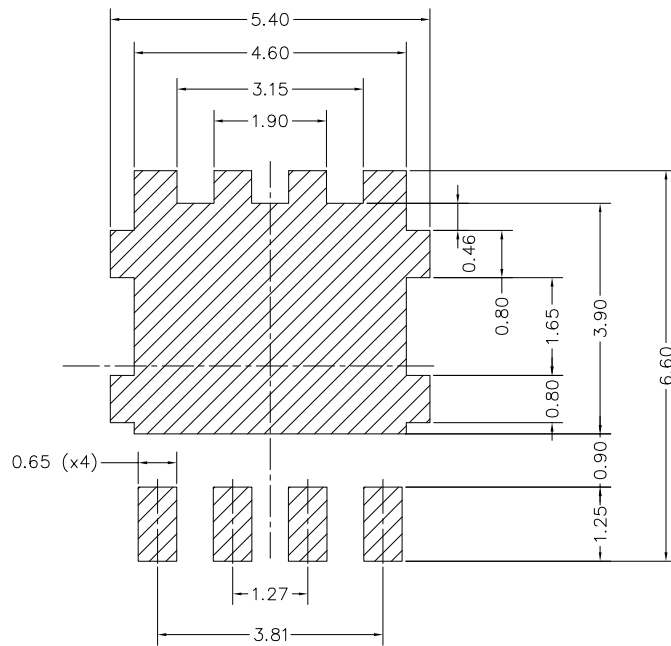

8231817_FOOTPRINT_rev24

3.2 PowerFLAT 5x6 packing information

Figure 19. PowerFLAT 5x6 tape (dimensions are in mm)

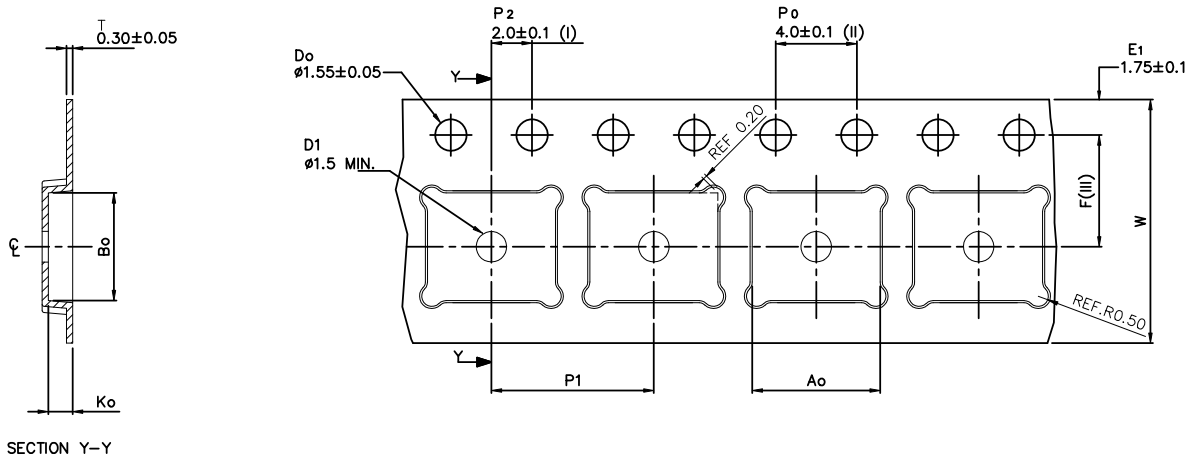

SECTION Y-Y

Ao	6.30 +/- 0.1
Bo	5.30 +/- 0.1
Ko	1.20 +/- 0.1
F	5.50 +/- 0.1
P1	8.00 +/- 0.1
W	12.00 +/- 0.3

(I) Measured from centreline of sprocket hole to centreline of pocket.

(II) Cumulative tolerance of 10 sprocket holes is ± 0.20 .

(III) Measured from centreline of sprocket hole to centreline of pocket

Base and bulk quantity 3000 pcs
All dimensions are in millimeters

8234350_Tape_rev_C

Figure 20. PowerFLAT 5x6 package orientation in carrier tape

Pin 1 identification

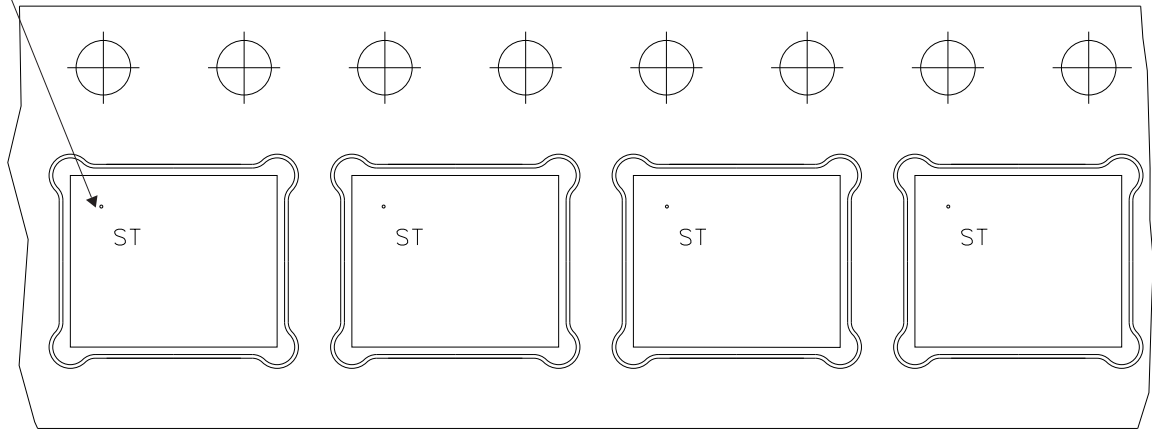
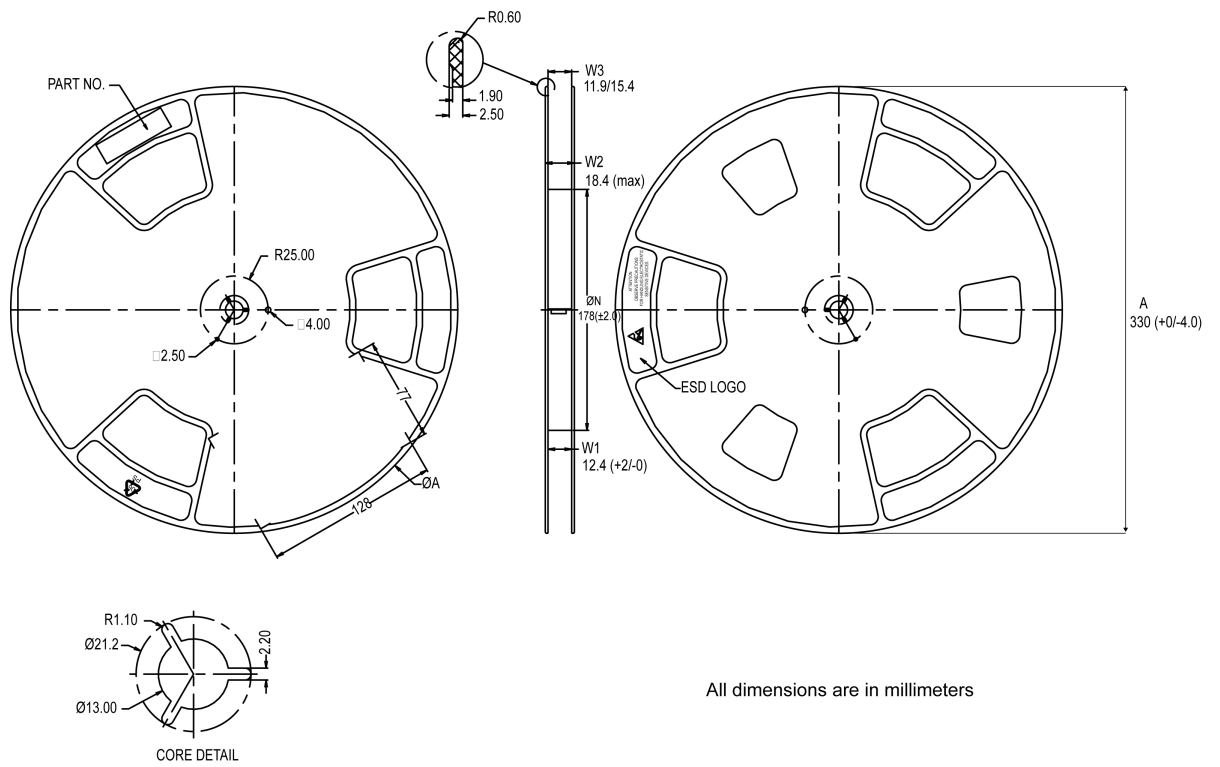

Figure 21. PowerFLAT 5x6 reel



8234350_Reel_rev_C

3.3 PowerFLAT 5x6 marking information

Figure 22. PowerFLAT 5x6 marking information

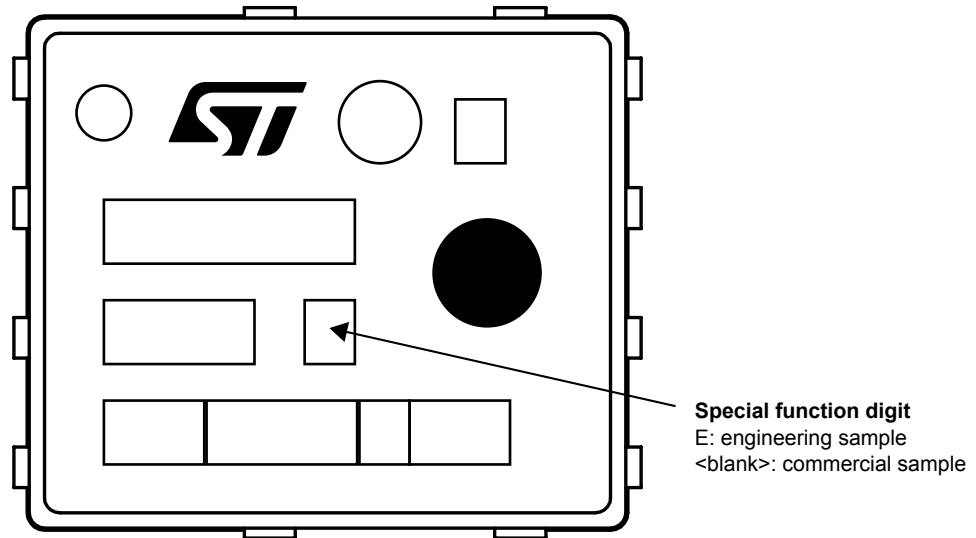

Note: *Engineering Samples: these samples can be clearly identified by a dedicated special symbol in the marking of each unit. These samples are intended to be used for electrical compatibility evaluation only; usage for any other purpose may be agreed only upon written authorization by ST. ST is not liable for any customer usage in production and/or in reliability qualification trials.*

Commercial Samples: fully qualified parts from ST standard production with no usage restrictions.

Revision history

Table 8. Document revision history

Date	Revision	Changes
22-Nov-2023	1	First release.
04-Nov-2024	2	Updated <i>Table 1. Absolute maximum ratings (at TC = 25 °C unless otherwise specified)</i> , <i>Table 4. Dynamic</i> and <i>Table 6. Source-drain diode</i> .
18-Mar-2025	3	Added <i>Section 2.1: Electrical characteristics (curves)</i> . Updated <i>Table 5. Switching times</i> . Minor text changes in <i>Table 1. Absolute maximum ratings (at TC = 25 °C unless otherwise specified)</i> .
04-Sep-2025	4	Updated <i>Table 2. Thermal data</i> . Updated <i>Figure 5. Safe operating area</i> , <i>Figure 2. Drain current vs case temperature</i> , <i>Figure 3. Typical output characteristics</i> and <i>Figure 4. Typical transfer characteristics</i> .
20-Feb-2026	5	Updated <i>Features</i> . Updated <i>Figure 3. Typical output characteristics</i> , <i>Figure 4. Typical transfer characteristics</i> , <i>Figure 8. Typical capacitance characteristics</i> and <i>Figure 12. Typical on-resistance vs gate-source voltage</i> . Minor text changes.

Contents

1	Electrical ratings	2
2	Electrical characteristics	3
2.1	Electrical characteristics (curves)	5
3	Package information	8
3.1	PowerFLAT 5x6 WF type C package information	8
3.2	PowerFLAT 5x6 packing information	10
3.3	PowerFLAT 5x6 marking information	12
	Revision history	13

IMPORTANT NOTICE – READ CAREFULLY

STMicroelectronics NV and its subsidiaries (“ST”) reserve the right to make changes, corrections, enhancements, modifications, and improvements to ST products and/or to this document at any time without notice.

In the event of any conflict between the provisions of this document and the provisions of any contractual arrangement in force between the purchasers and ST, the provisions of such contractual arrangement shall prevail.

The purchasers should obtain the latest relevant information on ST products before placing orders. ST products are sold pursuant to ST’s terms and conditions of sale in place at the time of order acknowledgment.

The purchasers are solely responsible for the choice, selection, and use of ST products and ST assumes no liability for application assistance or the design of the purchasers’ products.

No license, express or implied, to any intellectual property right is granted by ST herein.

Resale of ST products with provisions different from the information set forth herein shall void any warranty granted by ST for such product.

If the purchasers identify an ST product that meets their functional and performance requirements but that is not designated for the purchasers’ market segment, the purchasers shall contact ST for more information.

ST and the ST logo are trademarks of ST. For additional information about ST trademarks, refer to www.st.com/trademarks. All other product or service names are the property of their respective owners.

Information in this document supersedes and replaces information previously supplied in any prior versions of this document.

© 2026 STMicroelectronics – All rights reserved