

## Tiny dual-band GNSS low power and measurement engine modules



**LCC-18**  
(9.7 x 10.1 mm)



### Product status link

[Teseo-LIV4F](#)

### Product summary

|                          |                           |
|--------------------------|---------------------------|
| <b>Order code</b>        | Teseo-LIV4FTR             |
| <b>Marking</b>           | Teseo-LIV4F               |
| <b>Temperature range</b> | -40 °C ÷ 85 °C            |
| <b>Package</b>           | LCC-18<br>(9.7 x 10.1 mm) |
| <b>Packing</b>           | Tape and Reel             |

### Features

- Simultaneous multiconstellation and multi band GNSS (GPS/Galileo/Glonass/BeiDou/QZSS)
- IRNSS constellation ready
- GNSS raw measurement data
- -162 dBm tracking sensitivity
- Submeter positioning accuracy
- Embedded flash
- Firmware upgrade
- Free firmware configuration
- VCC/VBAT supply voltage range: 3.0 V to 3.63 V
- Tiny LCC-18 pin package (9.7 x 10.1 mm)
- Operating temperature (-40 °C ÷ 85 °C)
- 10 µA standby current consumption and 48.8 mA GNSS L1&L5 tracking current consumption

### Description

The Teseo-LIV4F module is an easy-to-use global navigation satellite system (GNSS) standalone low power module, embedding Teseo IV single die GNSS receiver IC working simultaneously on multiple constellations (GPS/Galileo/Glonass/BeiDou/QZSS) able to provide positioning or raw measurement data.

The Teseo-LIV4F module brings the proven accuracy and robustness of Teseo IV multi-bands chips to the reach of everyone: the embedded firmware and the complete evaluation environment save development time, while the compactness and cost-effectiveness of this solution make it ideal for several applications, such as insurance, goods tracking, drones, tolling, anti-theft systems, people and pet location, vehicle tracking, emergency calls, fleet management, vehicle sharing, diagnostics and public transportation.

Within its 9.7 x 10.1 mm tiny size, Teseo-LIV4F is offering superior accuracy thanks to the on-board temperature compensated crystal oscillator (TCXO) and a reduced time to first fix (TTFF) relying on its dedicated real time clock (RTC) oscillator.

Teseo-LIV4F also provides the real-time assisted GNSS able to predict satellite data based on previous observation of satellite.

Teseo-LIV4F module is a CE certified device system.

Teseo-LIV4F optimizes the time to market of the final applications with a temperature operating range from -40 °C to 85 °C.

# 1 Overview

## 1.1 GNSS performance

Receiver specifications:

- GPS/QZSS L1C/A (1575.42 MHz), L5C (1176.45 MHz)
- GLONASS L1OF (1592.9525 ÷ 1610.485 MHz)
- BeiDou B1i (1561.098 MHz), B2a (1207.14 MHz)
- Galileo E1 (1575.42 MHz), E5a (1176.45 MHz)
- SBAS L1C/A

**Table 1. GNSS performance**

| Parameter                                   | Specification           | GNSS  | GPS&BD | Unit |
|---|-------------------------|-------|--------|------|
| Time To First Fix <sup>(1)</sup>            | Cold start              | 28.5  | 28.5   | s    |
|   | Warm start              | 20.0  | 21.0   |      |
|   | Hot start               | 1.5   | 1.44   |      |
| Sensitivity <sup>(2)</sup>                  | Tracking <sup>(3)</sup> | -162  | -162   | dBm  |
|   | Cold start              | -148  | -148   |      |
| Max fix rate                                | -                       | 10    | 10     | Hz   |
| Horizontal position accuracy <sup>(4)</sup> | -                       | 0.8   | 0.7    | m    |
| Accuracy of time pulse                      | 99%                     | 20    | -      | ns   |
| Frequency of time pulse                     | 1                       | 1     | 1      | Hz   |
| Operational ITAR limits <sup>(5)</sup>      | Altitude                | 18000 | 18000  | m    |
|   | Velocity                | 515   | 515    | m/s  |

1. All satellites at -130 dBm - TTFF at 50%.

2. For BEIDOU tracking sensitivity refer to MEO sats. For GEO the tracking sensitivity is -151 dBm.

3. With external LNA.

4. CEP 50%, 24h static, roof antenna.

5. To comply with US International Traffic in Arms Regulations (ITAR), if both the ITAR altitude limit and the ITAR velocity limit are exceeded, consider the Teseo-LIV4F stops that provide the NMEA stream.

## 1.2 Block diagram

Figure 1. Module block schematic

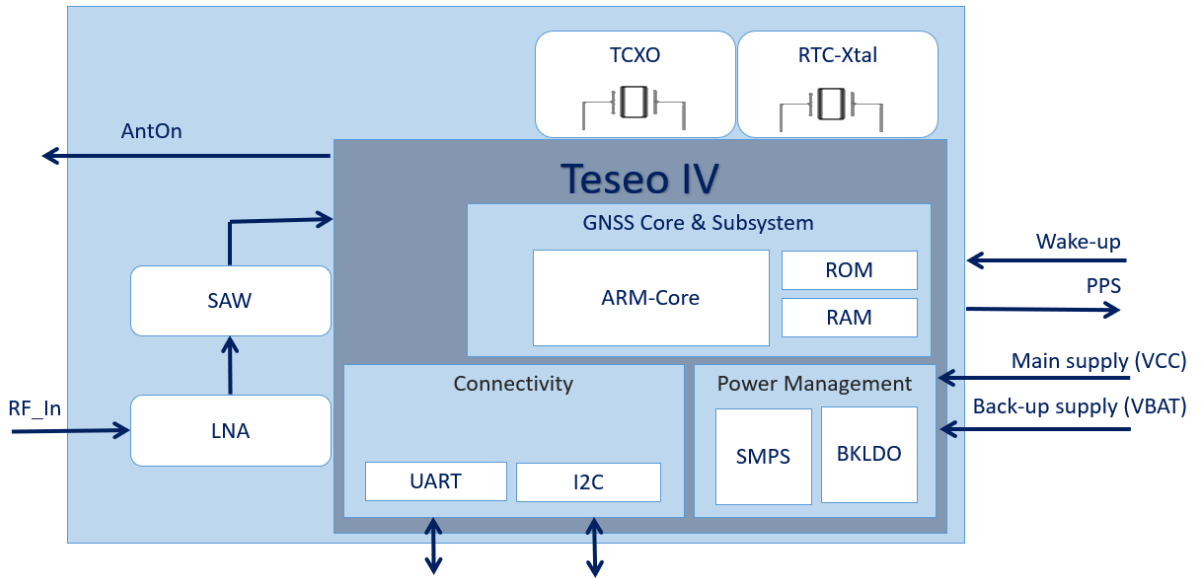

## 1.3 Pin configuration

Figure 2. Teseo-LIV4F module pins layout

|    |          |          |   |
|----|----------|----------|---|
| 10 | GND_RF   | nRESET   | 9 |
| 11 | RF_IN    | VCC      | 8 |
| 12 | GND_RF   | Reserved | 7 |
| 13 | Reserved | VBAT     | 6 |
| 14 | VCC_RF   | WakeUP   | 5 |
| 15 | Reserved | PPS      | 4 |
| 16 | I2C_SDA  | UART-RX  | 3 |
| 17 | I2C_SCL  | UART-TX  | 2 |
| 18 | PRG      | GND      | 1 |

## 1.4 Pin out description

**Table 2. Module pin out description**

| Pin # | Name     | I/O    | Description   |
|-------|----------|--------|---|
| 1     | GND      | Ground | Ground  |
| 2     | UART-TX  | O      | Serial port Tx (if not used, must be left floating)         |
| 3     | UART-RX  | I      | Serial port Rx  |
| 4     | PPS      | O      | Time pulse (PPS) (if not used, must be left floating)       |
| 5     | WakeUp   | I      | External interrupt pin (if not used, must be left floating) |
| 6     | VBAT     | I      | Backup voltage supply                                       |
| 7     | Reserved | -      | Reserved  |
| 8     | VCC      | I      | Main voltage supply   |
| 9     | nReset   | I      | nReset (if not used, must be left floating)                 |
| 10    | GND_RF   | Ground | Ground  |
| 11    | RF_IN    | I      | RF input signal<br>VCC voltage is available on the pin      |
| 12    | GND_RF   | Ground | Ground  |
| 13    | Reserved | -      | Reserved  |
| 14    | VCC_RF   | O      | External antenna supply (voltage equals to VCC, pin 8)      |
| 15    | Reserved | -      | Reserved  |
| 16    | I2C_SDA  | I/O    | I <sup>2</sup> C data (if not used, must be left floating)  |
| 17    | I2C_SCL  | I/O    | I <sup>2</sup> C clock (if not used, must be left floating) |
| 18    | PRG      | I      | Program or WakeUp from DeepStandby                          |

## 2 Supported GNSS constellation

---

The embedded firmware supports all the GNSS constellations: GPS, GLONASS, GALILEO, BEIDOU and QZSS (ready for IRNSS). The user can select what the application needs by firmware configuration.

### 2.1 GPS

The Teseo-LIV4F GNSS module can receive and process the L1C/A and L5C signals provided by the global positioning system (GPS).

### 2.2 GLONASS

The Teseo-LIV4F module can receive and process the GLONASS L1OF signal.

### 2.3 BeiDou

The Teseo-LIV4F modules can receive and process BeiDou B1I and B2a signals.

### 2.4 Galileo

The Teseo-LIV4F can receive and process Galileo E1 and E5 signals.

### 2.5 IRNSS

The Teseo-LIV4F is ready for IRNSS using a dedicated firmware.

## 3 Augmentation systems

### 3.1 Satellite\_based augmentation system

Teseo-LIV4F supports SBAS. SBAS is a wide area differential GPS (WADGPS). It is a system which provides differential GPS corrections data; SBAS includes the WAAS within the United States, the EGNOS within Europe, the multifunctional transport satellite (MTSAT)-based MSAS within Japan and southeast Asia, and the GPS and GEO augmented navigation (GAGAN) system in India.

The SBAS data correction is used in the GNSS algorithm to provide a better position estimation. The overall SBAS differential correction mechanism can be conceived as built in 2 phases:

- The “Acquire and tracking” phase.
- The “Decoding” phase.

The “Acquire and track” phase relates to the capacity of the acquisition engine to reliably track the configured SBAS satellite; during decoding phase the SBAS message can be decoded to fetch the differential corrections.

The current longitude limits for each service are:

- WAAS -180 degrees to -25 degrees
- EGNOS -25 degrees to +50 degrees
- GAGAN +50 degrees to +100 degrees
- MSAS +100 degrees to +180 degrees

The Teseo-LIV4F software with SBAS capability implements a command interface at the NMEA level to allow interaction with the SBAS library. It supports commands to enable/disable the SBAS functionality.

### 3.2 QZSS

The quasi-zenith satellite system (QZSS) is the Japanese regional communication service and positioning information for the mobile environment in the GPS L1C/A band. QZSS in conjunction with GPS signals provide GNSS augmentation service for the Pacific region covering Japan and Australia. QZSS satellites are placed in a periodic highly elliptical orbit (HEO): these orbits allow the satellites to “dwell” for more than 12 hours a day at an elevation above 70° (it means that they appear almost overhead most of the time).

### 3.3 Differential GPS

Teseo-LIV4F supports (using a dedicated firmware available on [www.st.com](http://www.st.com)) differential GPS data according to RTCM v3 (radio technical commission for maritime services).

Teseo-LIV4F supports the RTCM input command RTCM SC-104 and the RTCM input commands in [Table 3](#).

**Table 3. Differential GPS**

| Message type | Description  |
|--------------|--|
| 1005         | Stationary RTK reference station ARP                     |
| 1006         | Stationary RTK reference station ARP with antenna height |
| 1033         | Receiver and antenna descriptors                         |
| 1019         | GPS ephemerides  |
| 1020         | GLONASS ephemerides                                      |
| 1042         | BeiDou satellite ephemeris data                          |
| 1044         | QZSS ephemerides   |
| 1045         | Galileo F/NAV satellite ephemeris data                   |
| 1046         | Galileo I/NAV satellite ephemeris data                   |
| 1074         | GPS MSM4   |
| 1075         | GPS MSM5   |
| 1076         | GPS MSM6   |
| 1077         | GPS MSM7   |
| 1084         | GLONASS MSM4   |
| 1085         | GLONASS MSM5   |
| 1086         | GLONASS MSM6   |
| 1087         | GLONASS MSM7   |
| 1094         | Galileo MSM4   |
| 1095         | Galileo MSM5   |
| 1096         | Galileo MSM6   |
| 1097         | Galileo MSM7   |
| 1114         | QZSS MSM4  |
| 1115         | QZSS MSM5  |
| 1116         | QZSS MSM6  |
| 1117         | QZSS MSM7  |
| 1124         | BeiDou MSM4  |
| 1125         | BeiDou MSM5  |
| 1126         | BeiDou MSM6  |
| 1127         | BeiDou MSM7  |

---

## 4 Assisted GNSS

---

GNSS receivers need accurate satellite position data from at least 4 satellites to produce a fix. Accurate satellite data, ephemeris data, are valid for several hours based on the active constellations. After that time, a receiver must download new ephemeris data. Ephemeris download can take from dozens of seconds to several minutes, hours or can fail to download. Assisted-GNSS is a mechanism to provide ephemeris assistance from external source; this reduces considerably the time to get fix especially in critical environments when the ephemeris download time could be very long. Teseo-LIV4F supports one type of Assisted GNSS: real time assisted GNSS.

### 4.1 Real-time Assisted GNSS

Real-time Assisted GNSS (RT-AGNSS) solution is a server based assisted GNSS. It requires a network connection to download assistance data from the server.

RT-AGNSS works downloading by an assistance server the real time ephemeris data. Server access is allowed thanks to internal keyword provided by Teseo-LIV4F to the host processor and the acquired real-time data have to be provided to Teseo-LIV4F.

Proprietary NMEA commands are supported on Teseo-LIV4F to acquire the credential access to the external server and to inject the data to Teseo-LIV4F.

STMicroelectronics partner provides available server solution access on Teseo-LIV4F solution.

Real-time A-GNSS allows continuous real-time satellite position determination.

---

## 5 Clock generation

---

### 5.1 Temperature-compensated crystal oscillator (TCXO)

Highly stable oscillator controls the down conversion process in the RF block of the Teseo-LIV4F. Characteristics of this component are important factors for higher sensitivity to maximize performances especially in weak-signal environments, as well as to minimize the time to first fix (TTFF) and improve navigation stability.

### 5.2 Real-time clock (RTC)

This is an always-on power domain dedicated to RTC logic (backup system) and supplied with a dedicated voltage regulator.

The RTC provides a high-resolution clock. It keeps the time when the system is inactive and it is internally used to wake up the system when in low power mode. It has a clock trimming feature to compensate for the accuracy of the crystal and a secured time update.

## 6 I/O interfaces

Teseo-LIV4F supports the following I/O interfaces:

- UART port
- I<sup>2</sup>C port

NMEA protocol is supported on both UART and I<sup>2</sup>C ports.

### 6.1 UART

The universal asynchronous receiver/transmitter (UART) supports much of the functionality of the industry-standard 16C650 UART.

The UART performs serial-to-parallel conversion on data asynchronously received from a peripheral device on the UART-RX pin, and parallel-to-serial conversion on data written by CPU for transmission on the UART-TX pin. The transmit and receive paths are buffered with internal FIFO memories allowing up to 64 data bytes for transmission, and 64 data bytes with 4-bit status (break, frame, parity, and overrun) for receive.

### 6.2 I<sup>2</sup>C

Teseo-LIV4F includes a slave I<sup>2</sup>C interface configurable.

Unlike all other interfaces, I<sup>2</sup>C is not able to communicate in full-duplex mode; it uses only two bidirectional open-drain lines, a serial data line on pin I2C\_SDA and a serial clock line on pin I2C\_SCL, pulled up with resistors.

Teseo-LIV4F receiver always acts as a slave and it cannot initiate data transmission on the bus; host must periodically poll the receiver to check about data availability.

The main features are:

- Normal speed (100 kHz) and fast speed (400 kHz) supported.
- I<sup>2</sup>C-slave address configurable using the firmware configurator.

## 7 Antenna voltage supply (VCC\_RF, pin 14)

Teseo-LIV4F has built-in LNA and SAW. It is recommended to use an active antenna with gain less than 36 dB and the noise figure less than 1.5 dB.

Teseo-LIV4F has built-in short circuit detection and open circuit detection function, which can detect the status of normal connection, and send out antenna status prompt messages in NMEA data:

- Short circuit protection: once an overcurrent is detected at the VCC\_RF pin (pin 14), the module will cut off this power supply automatically to prevent permanent damages.
- Open circuit detection: Teseo-LIV4F can detect an open circuit in the antenna.

Table 4 reports the antenna status threshold.

**Table 4. Antenna Status current threshold**

| Antenna status                  | Status output | VCC_RF on current range                                       |
|---------------------------------|---------------|---|
| Open circuit                    | OPEN          | $0 < VCC\_RF \leq 1 \text{ mA}$                               |
| Regular circuit or open circuit | OK or OPEN    | $1 \text{ mA} < VCC\_RF \leq 2 \text{ mA}$                    |
| Regular circuit                 | OK            | $2 \text{ mA} < VCC\_RF \leq 40 \text{ mA} \pm 5 \text{ mA}$  |
| Short circuit                   | SHORT         | $40 \text{ mA} \pm 5 \text{ mA} < VCC\_RF \leq 55 \text{ mA}$ |

## **8 Firmware update support**

---

The Teseo-LIV4F receiver module can be updated with new firmware releases. The latest firmware version is available at [www.st.com](http://www.st.com) and it can be installed on Teseo-LIV4F using the available PC tool Teseo-Suite available at [www.st.com](http://www.st.com).

Detailed information is available on Teseo-LIV4F software user manual.

## 9 Firmware configuration

---

All configuration parameters are grouped in a data block. Each field is addressed by a unique ID. The IDs are made by three digits: the most significant one represents the parameter type and the others are used to identify different parameters of the same type.

Default setting of configuration data block is hard coded into the binary image file.

A new configuration can be built using the PC tool Teseo-Suite, available at [www.st.com](http://www.st.com) or using runtime configuration commands raised by the host.

---

## 10 Power mode

---

Standby mode is the mode where only low power backup domain is running. It means VBAT (pin 22) must be always maintained.

It allows to have very low current consumption and fast GNSS reacquisition at the end of the standby time due to RTC.

## 11 Regulatory compliance

The Teseo-LIV4F module has been certified according to the following standards:

- Radio equipment directive (RED) 2014/53/EU
- EN 62368-1:2020+A11:2020
- ETSI EN 301 489-1 V2.2.3 + ETSI EN 301 489-19 V2.2.0
- ETSI EN 303 413 V1.2.1

The module is provided with CE marking:



The certificate of conformity is available/downloadable at the following webpage: [www.st.com](http://www.st.com) at the Teseo-LIV4F page.

For additional information refer to:

STMicroelectronics Via C. Olivetti, 2 Agrate Brianza (MB) 20864 (ITALY)

The Teseo-LIV4F module current production firmware release is:

\$PSTMVER,GNSSLIB\_8.6.x.xx\_ARM\*xx

The manufacturer, STMicroelectronics, declares that the Teseo-LIV4F radio equipment complies with the 2014/53/UE directive.

The full text of the EU declaration of conformity is available at the following internet address:

[www.st.com](http://www.st.com) at the Teseo-LIV4F page.

### 11.1 Approvals

The Teseo-LIV4F module is RoHS and WEEE compliant.



In the countries belonging to the European Union, the Teseo-LIV4F is subject to differentiated recycling at the end of its life cycle.

The Teseo-LIV4F must be disposed as an undifferentiated waste or with other domestic wastes.

The abandonment of this waste in the environment, or in landfills, or in waste-to-energy plants, has as consequence the pollution of soil, air and water, with repercussions on human health.

---

## 12 Electrical characteristics

---

### 12.1 Parameter conditions

Unless otherwise specified, all voltages are referred to GND.

### 12.2 Minimum and maximum values

Unless otherwise specified the minimum and maximum values are guaranteed in the worst conditions of ambient temperature, supply voltage and frequencies by tests in production on 100% of the devices with an operating ambient temperature at  $T_C = 25\text{ }^\circ\text{C}$ .

### 12.3 Typical values

Unless otherwise specified, typical data are based on  $T_C = 25\text{ }^\circ\text{C}$ ,  $V_{CC} = 3.3\text{ V}$  and  $V_{BAT} = 3.3\text{ V}$ .

They are given only as design guidelines and are not tested.

Unless otherwise specified, all typical curves are given only as design guidelines and are not tested.

## 12.4 Absolute maximum ratings

This product contains devices to protect the inputs against damage due to high static voltages, however it is advisable to take normal precautions to avoid application of any voltage higher than the specified maximum rated voltages.

**Table 5. Module supply voltage characteristics**

| Symbol | Parameter                   | Min | Typ | Max  | Unit |
|--------|-----------------------------|-----|-----|------|------|
| VCC    | Digital supply voltage      | 3.0 | 3.3 | 3.63 | V    |
| VBAT   | Backup input supply voltage | 3.0 | 3.3 | 3.63 | V    |

**Table 6. Module thermal characteristics**

| Symbol            | Parameter                   | Min | Max | Unit |
|-------------------|-----------------------------|-----|-----|------|
| T <sub>oper</sub> | Operative temperature range | -40 | 85  | °C   |
| T <sub>stor</sub> | Storage temperature range   | -40 | 85  | °C   |

**Table 7. Module current consumption**

| Symbol            | Parameter       | Test condition  | Typ  | Unit |
|-------------------|-----------------|---|------|------|
| Power consumption | Test condition  | GNSS L1 + L5;<br>T <sub>C</sub> = 25 °C;<br>VCC = VBAT = 3.3 V;           | 48.8 | mA   |
|                   | SW-STANDBY mode | RTC running @ 32.768 kHz;<br>T <sub>C</sub> = 25 °C;<br>VCC = VBAT = 3.3V | 10   | µA   |

## 12.5 Recommended DC operating conditions

**Table 8. Recommended DC operating conditions**

| Symbol | Parameter                                   | Min | Typ | Max  | Unit |
|--------|---|-----|-----|------|------|
| VCC    | Power supply pins                           | 3.0 | 3.3 | 3.63 | V    |
| VBAT   | Power supply pins for backup internal logic | 3.0 | 3.3 | 3.63 | V    |

**Table 9. I/O voltage characteristics for nReset and PRG pins**

| Parameter          | Condition | Min              | Typ | Max              | Unit       |
|--------------------|-----------|------------------|-----|------------------|------------|
| Input high voltage | -         | $VBAT \cdot 0.7$ | -   | VBAT             | V          |
| Input low voltage  | -         | 0                | -   | $VBAT \cdot 0.3$ | V          |
| Pull-up resistance | -         | 18               | -   | 84               | k $\Omega$ |

**Table 10. I/O voltage characteristics for the other pins**

| Parameter           | Condition   | Min             | Typ | Max             | Unit       |
|---------------------|-------------|-----------------|-----|-----------------|------------|
| Input high voltage  | -           | $VCC \cdot 0.7$ | -   | VCC             | V          |
| Input low voltage   | -           | 0               | -   | $VCC \cdot 0.3$ | V          |
| Pull-up resistance  | -           | 35              | -   | 84              | k $\Omega$ |
| Output high voltage | VCC = 3.3 V | 2.64            | -   | -               | V          |
| Output low voltage  | VCC = 3.3 V | -               | -   | 0.4             | V          |

## 13 Reflow soldering profile

The Teseo-LIV4F is a high temperature strength surface mount GNSS module supplied on an 18-pin, 6-layer PCB. The final assembly recommended reflow profiles are indicated here below.

Soldering phase must be executed with care: to avoid undesired melting phenomenon, particular attention has to be taken on the set up of the peak temperature.

Here below some suggestions about the temperature profile based on the following recommendations.

**Table 11. Module soldering profile values**

| Profile feature                                       | PB-free assembly |
|---|------------------|
| Average ramp-up rate ( $T_{SMAX}$ to $T_P$ )          | 3 °C/sec max     |
| Preheat:  |                  |
| - Temperature min ( $T_{Smin}$ )                      | 150 °C           |
| - Temperature max ( $T_{Smax}$ )                      | 200 °C           |
| - Time ( $t_{Smin}$ to $t_{Smax}$ ) ( $t_s$ )         | 60 ± 100 sec     |
| Time maintained above:                                |                  |
| - Temperature ( $T_L$ )                               | 217° C           |
| - Time ( $t_L$ )                                      | 60 ± 70 sec      |
| Peak temperature ( $T_P$ )                            | 245 ± 5 °C       |
| Time within 5 °C of actual peak temperature ( $T_P$ ) | 10 ± 20 sec      |
| Ramp-down rate (from $T_P$ to 100 °C)                 | 1.9 °C/sec       |
| Time from 25 °C to peak temperature                   | 8 minutes max.   |

**Figure 3. Module soldering profile graph**

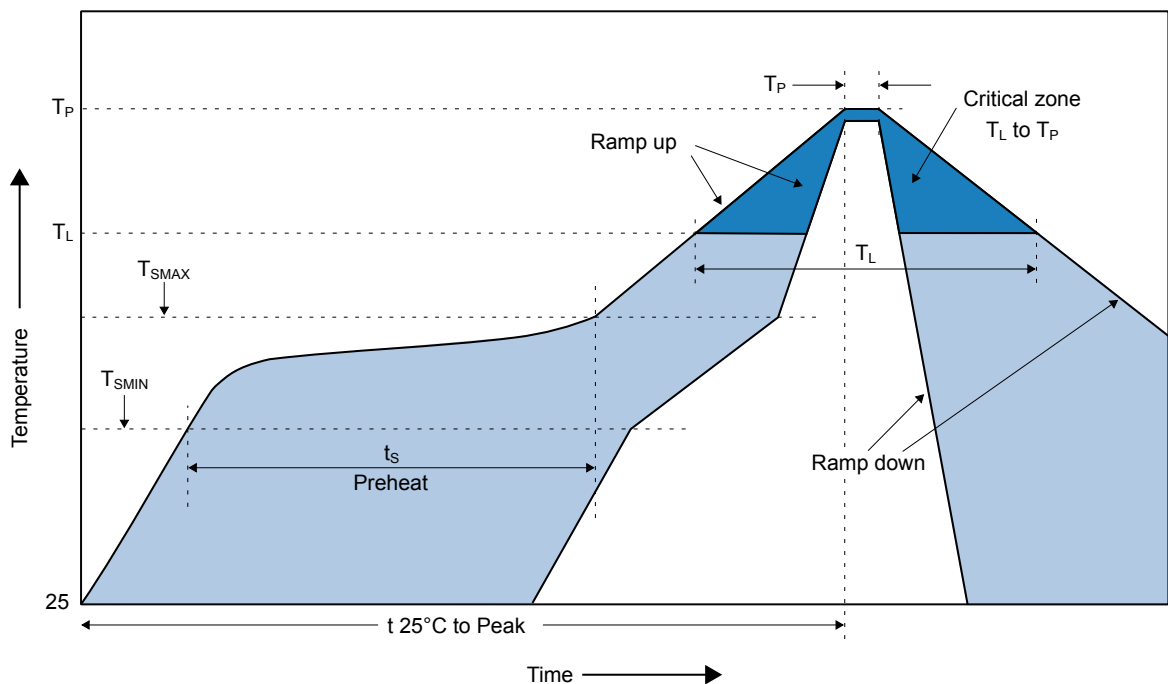

### 13.1 Cooling phase

A controlled cooling avoids negative metallurgical effects of the solder (solder becomes more brittle) and possible mechanical tensions in the products. Controlled cooling helps to achieve bright solder fillets with a good shape and low contact angle.

Temperature fall rate: max 4 °C/s

To avoid falling off, the Teseo module should be placed on the topside of the motherboard during soldering.

### 13.2 Repeated reflow soldering

Only single reflow soldering processes are recommended for boards populated with Teseo modules. To avoid upside down orientation during the second reflow cycle, the Teseo module should not be submitted to two reflow cycles on a board populated with components on both sides. In this case, the Teseo module should always be placed on that side of the board which is submitted into the last reflow cycle.

*Important: Repeated reflow soldering processes and soldering the Teseo module upside down are not recommended.*

### 13.3 Rework

The Teseo module can be unsoldered from the baseboard using a hot air gun. When using a hot air gun for unsoldering the module, a maximum of one reflow cycle is allowed. In general, we do not recommend using a hot air gun because this is an uncontrolled process and might damage the module.

**Attention:** *Use of a hot air gun can lead to overheating and severely damage the module. Always avoid overheating the module.*

After the module is removed, clean the pads before placing and hand soldering a new module.

*Important: Never attempt a rework on the module itself, for example, replace individual components. Such actions immediately terminate the warranty.*

## 14 Shipping information

Teseo-LIV4F is delivered as reeled tapes.

To protect it from physical damage, the reels are individually packed in cartons.

### 14.1 Reels

Teseo-LIV4F reel specification is as shown in Figure 4:

Figure 4. Module carrier type specifications

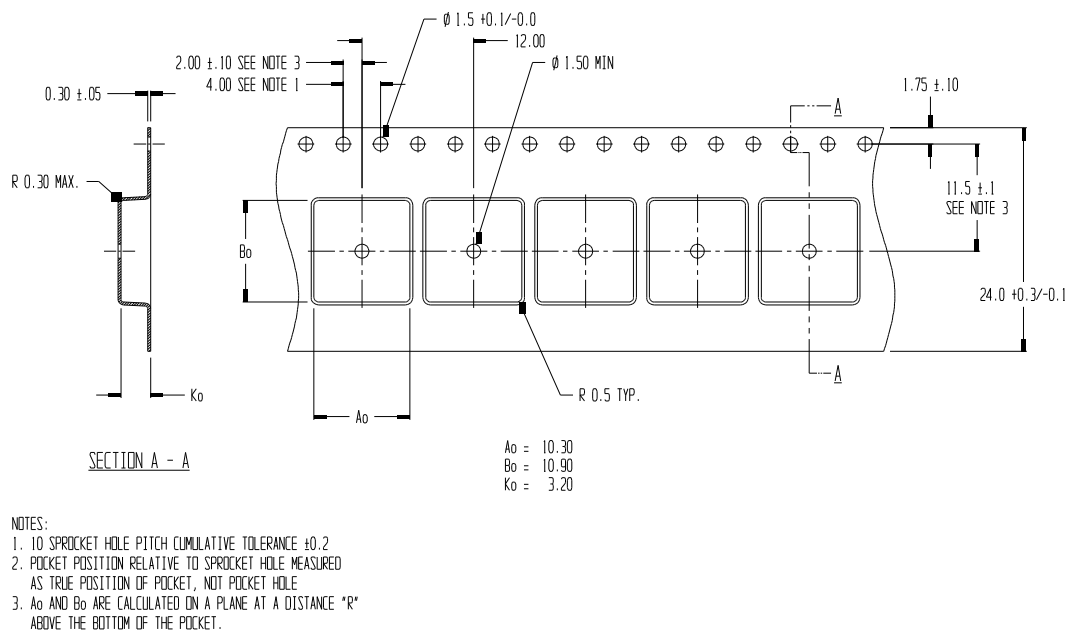

Figure 5. Module orientation specifications

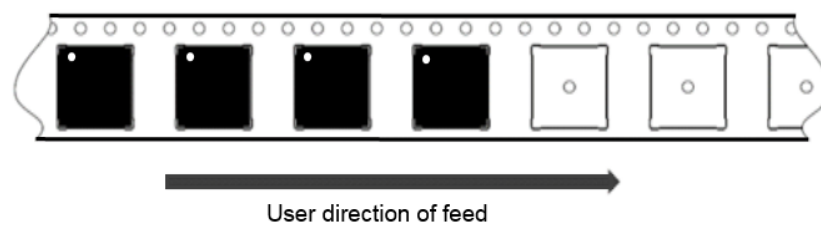

Figure 6. Module cover tape specifications

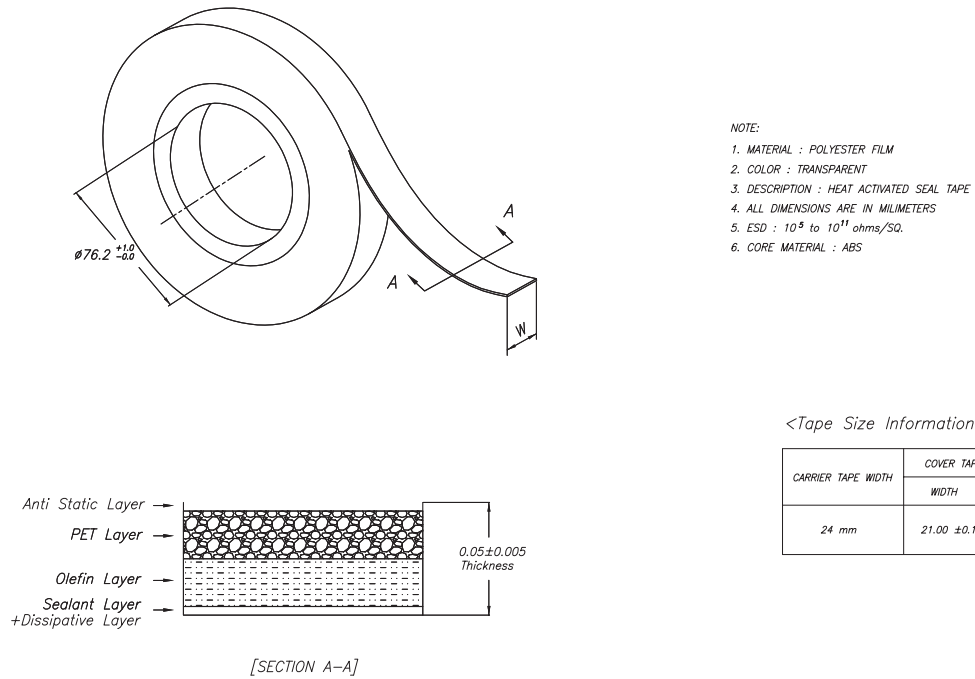

Figure 7. Module plastic reel specifications

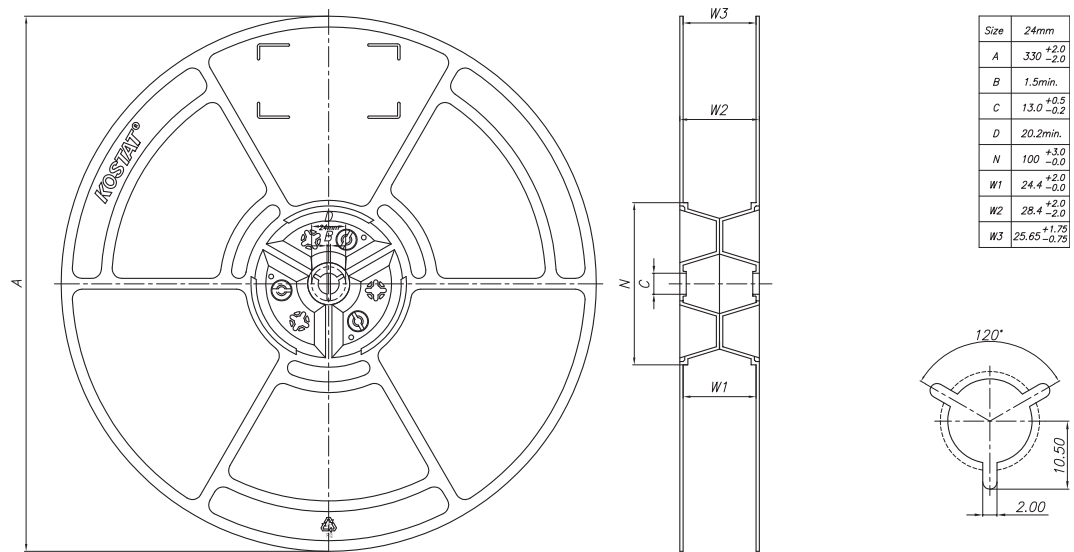
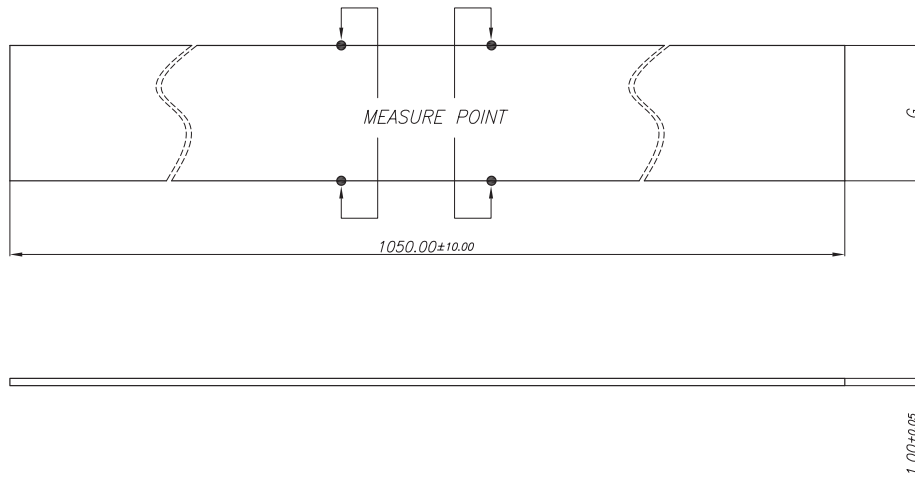

Figure 8. Module PB band specifications



UNIT: mm

| WIDTH (mm) | 8    | 12    | 16    | 24    | 32    | 44    | 56    |
|------------|------|-------|-------|-------|-------|-------|-------|
| G (± 0.10) | 8.20 | 12.20 | 16.20 | 24.20 | 32.20 | 44.20 | 56.20 |

## 14.2 Packing cartons for reels

To avoid damage each Teseo-LIV4F reel has a dedicated carton box of 340 x 340 x 38 mm.

## 14.3 ESD handling precautions

Teseo-LIV4F module is an electrostatic sensitive device (ESD). Observe precautions for handling! Failure to observe these precautions can result in severe damage to the GNSS receiver.

GNSS receivers are electrostatic sensitive devices (ESD) and require special precautions when handling. Care must be exercised when handling patch antennas, due to the risk of electrostatic charges.

## 14.4 Moisture sensitivity levels

The moisture sensitivity level (MSL) relates to the packaging and handling precautions required. Teseo-LIV4F modules are rated at MSL level 3 (three).

## 15 Labelling information

The labelling of Teseo-LIV4F reports product information.  
Information layout of the product is shown in Figure 9:

Figure 9. Module labelling information

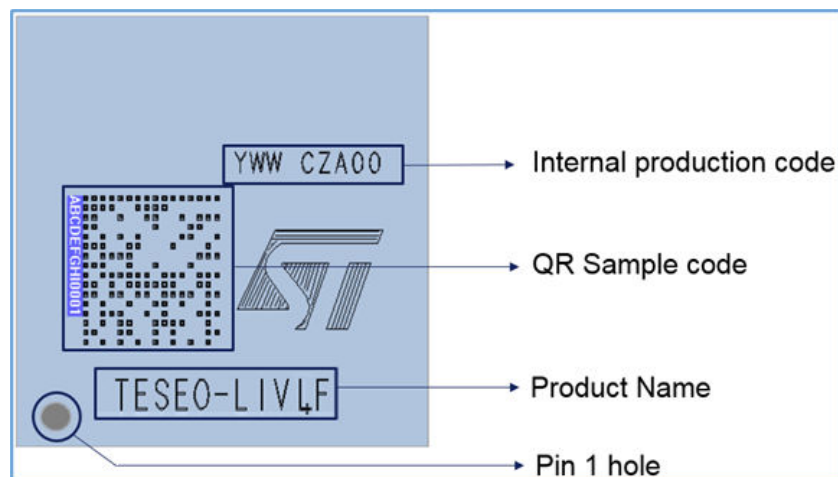

Information descriptions are reported in the following table:

Table 12. Module labelling information description

| Items                    | Description  |
|--------------------------|--|
| Internal production code | Production date (YWW: year-week), lot identifier.              |
| QR sample code           | QR sample code used for traceability information of any parts. |
| Product name             | Official product name for ordering code.                       |
| Pin 1 hole               | Hole on the shield to identify Pin 1.                          |

## 16 Package information

To meet environmental requirements, ST offers these devices in different grades of **ECOPACK** packages, depending on their level of environmental compliance. ECOPACK specifications, grade definitions, and product status are available at: [www.st.com](http://www.st.com). ECOPACK is an ST trademark.

### 16.1 LCC-18 (9.7 x 10.1 mm) package information

Figure 10. LCC-18 (9.7 x 10.1 mm) package outline

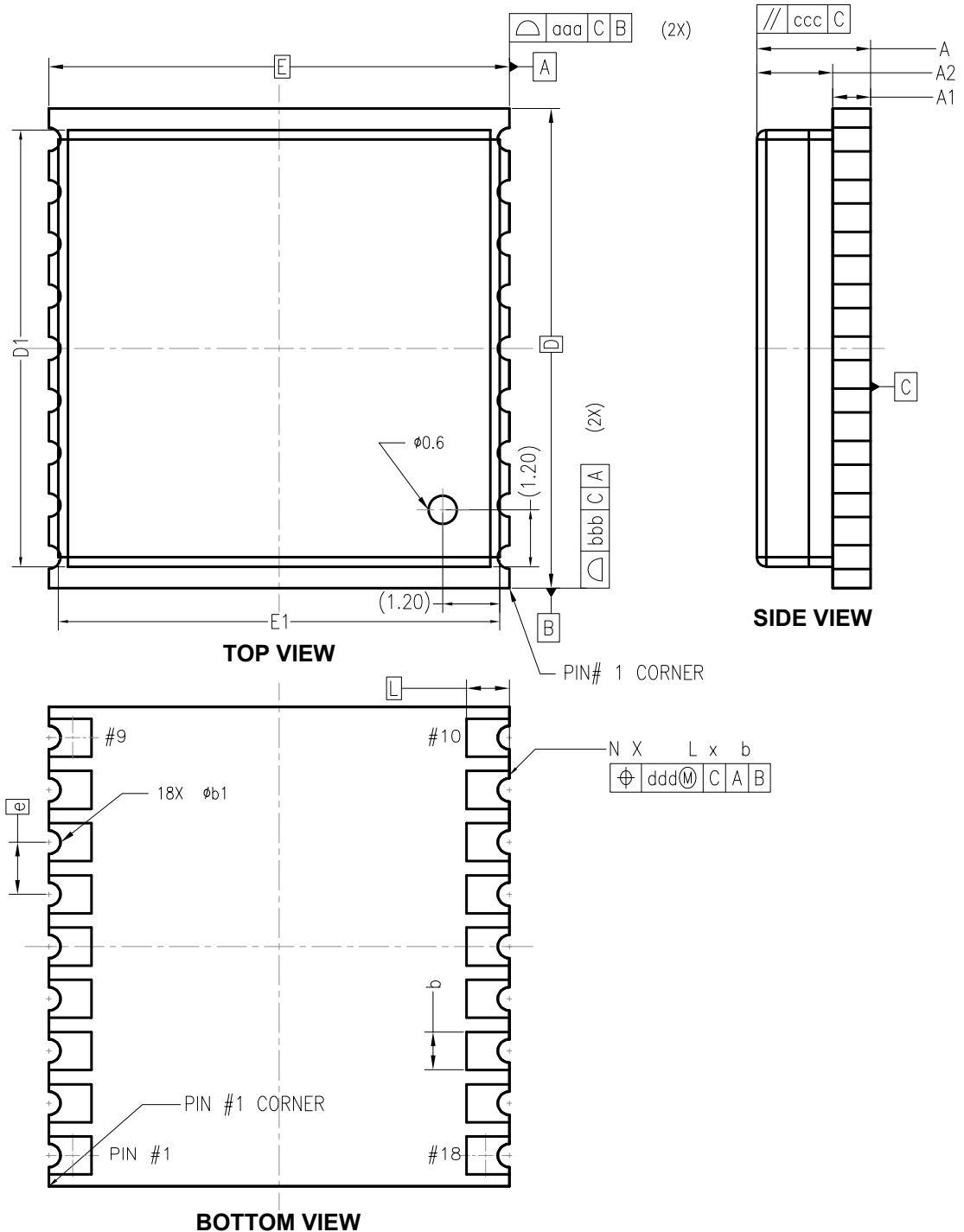

**Table 13. Package dimensions**

| Symbol | Min   | Norm       | Max   |
|--------|-------|------------|-------|
| A      | 2.25  | 2.40       | 2.55  |
| A1     | 0.70  | 0.80       | 0.90  |
| A2     | -     | (1.6) Ref. | -     |
| b      | 0.70  | 0.80       | 0.90  |
| b1     | -     | (0.5) Ref. | -     |
| D      | 10.00 | 10.10      | 10.20 |
| D1     | -     | (9.2) Ref. | -     |
| E      | 9.60  | 9.70       | 9.80  |
| E1     | -     | (9.3) Ref. |       |
| 3      | 1.00  | 1.1        | 1.20  |
| G      | -     | 4x (0.25)  | -     |
| L      | 0.80  | 0.9        | 1.00  |
| N      | -     | 18         |       |

**Table 14. Tolerance of form and position**

| Symbol | Tolerance of form and position |
|--------|--------------------------------|
| aaa    | 0.20                           |
| bbb    | 0.20                           |
| ccc    | 0.15                           |
| ddd    | 0.10                           |
| Note   | ASE Dwg No. 97SPP03748B001_XO1 |

## Revision history

**Table 15. Document revision history**

| Date        | Revision | Changes  |
|-------------|----------|--|
| 04-Apr-2022 | 1        | Initial release.   |
| 20-Mar-2023 | 2        | Updated <i>Table 10. Module soldering profile values.</i>  |
| 30-Mar-2023 | 3        | Updated <i>Table 11. Module soldering profile values.</i>  |
| 04-Jul-2023 | 4        | Added <i>Section 3.3 Differential GPS.</i>   |
| 03-Oct-2023 | 5        | Added: <ul style="list-style-type: none"> <li>• <i>Section 13.1 Cooling phase;</i></li> <li>• <i>Section 13.2 Repeated reflow soldering;</i></li> <li>• <i>Section 13.3 Rework.</i></li> </ul> The device Teseo-LIV4FM has added and the document has been updated accordingly.  |
| 30-May-2024 | 6        | The part number Teseo-LIV4FM have been removed and the document has been updated accordingly.<br>Added Teseo LOGO.<br>Updated <i>Features, Product status link / summary and Description.</i><br>Updated <i>Figure 2. Teseo-LIV4F module pins layout.</i><br>Minor text changes. |
| 02-Mar-2026 | 7        | Updated <i>Figure 4. Module carrier type specifications ; Figure 10. LCC-18 (9.7 x 10.1 mm) package outline; Table 13. Package dimensions and Table 14. Tolerance of form and position.</i><br>Minor text changes.   |

## Contents

|           |   |           |
|-----------|---|-----------|
| <b>1</b>  | <b>Overview</b>                                   | <b>2</b>  |
| 1.1       | GNSS performance                                  | 2         |
| 1.2       | Block diagram                                     | 3         |
| 1.3       | Pin configuration                                 | 3         |
| 1.4       | Pin out description                               | 4         |
| <b>2</b>  | <b>Supported GNSS constellation</b>               | <b>5</b>  |
| 2.1       | GPS   | 5         |
| 2.2       | GLONASS   | 5         |
| 2.3       | BeiDou  | 5         |
| 2.4       | Galileo   | 5         |
| 2.5       | IRNSS   | 5         |
| <b>3</b>  | <b>Augmentation systems</b>                       | <b>6</b>  |
| 3.1       | Satellite_based augmentation system               | 6         |
| 3.2       | QZSS  | 6         |
| 3.3       | Differential GPS                                  | 7         |
| <b>4</b>  | <b>Assisted GNSS</b>                              | <b>8</b>  |
| 4.1       | Real-time Assisted GNSS                           | 8         |
| <b>5</b>  | <b>Clock generation</b>                           | <b>9</b>  |
| 5.1       | Temperature-compensated crystal oscillator (TCXO) | 9         |
| 5.2       | Real-time clock (RTC)                             | 9         |
| <b>6</b>  | <b>I/O interfaces</b>                             | <b>10</b> |
| 6.1       | UART  | 10        |
| 6.2       | I <sup>2</sup> C                                  | 10        |
| <b>7</b>  | <b>Antenna voltage supply (VCC_RF, pin 14)</b>    | <b>11</b> |
| <b>8</b>  | <b>Firmware update support</b>                    | <b>12</b> |
| <b>9</b>  | <b>Firmware configuration</b>                     | <b>13</b> |
| <b>10</b> | <b>Power mode</b>                                 | <b>14</b> |
| <b>11</b> | <b>Regulatory compliance</b>                      | <b>15</b> |
| 11.1      | Approvals   | 15        |
| <b>12</b> | <b>Electrical characteristics</b>                 | <b>16</b> |
| 12.1      | Parameter conditions                              | 16        |
| 12.2      | Minimum and maximum values                        | 16        |
| 12.3      | Typical values                                    | 16        |

---

|           |  |           |
|-----------|--|-----------|
| 12.4      | Absolute maximum ratings . . . . .                   | 17        |
| 12.5      | Recommended DC operating conditions . . . . .        | 18        |
| <b>13</b> | <b>Reflow soldering profile . . . . .</b>            | <b>19</b> |
| 13.1      | Cooling phase . . . . .                              | 20        |
| 13.2      | Repeated reflow soldering . . . . .                  | 20        |
| 13.3      | Rework . . . . .                                     | 20        |
| <b>14</b> | <b>Shipping information . . . . .</b>                | <b>21</b> |
| 14.1      | Reels . . . . .                                      | 21        |
| 14.2      | Packing cartons for reels . . . . .                  | 23        |
| 14.3      | ESD handling precautions . . . . .                   | 23        |
| 14.4      | Moisture sensitivity levels . . . . .                | 23        |
| <b>15</b> | <b>Labelling information . . . . .</b>               | <b>24</b> |
| <b>16</b> | <b>Package information . . . . .</b>                 | <b>25</b> |
| 16.1      | LCC-18 (9.7 x 10.1 mm) package information . . . . . | 25        |
|           | <b>Revision history . . . . .</b>                    | <b>27</b> |

## List of tables

|                  |  |    |
|------------------|--|----|
| <b>Table 1.</b>  | GNSS performance . . . . .                                   | 2  |
| <b>Table 2.</b>  | Module pin out description . . . . .                         | 4  |
| <b>Table 3.</b>  | Differential GPS. . . . .                                    | 7  |
| <b>Table 4.</b>  | Antenna Status current threshold . . . . .                   | 11 |
| <b>Table 5.</b>  | Module supply voltage characteristics. . . . .               | 17 |
| <b>Table 6.</b>  | Module thermal characteristics . . . . .                     | 17 |
| <b>Table 7.</b>  | Module current consumption . . . . .                         | 17 |
| <b>Table 8.</b>  | Recommended DC operating conditions . . . . .                | 18 |
| <b>Table 9.</b>  | I/O voltage characteristics for nReset and PRG pins. . . . . | 18 |
| <b>Table 10.</b> | I/O voltage characteristics for the other pins . . . . .     | 18 |
| <b>Table 11.</b> | Module soldering profile values . . . . .                    | 19 |
| <b>Table 12.</b> | Module labelling information description . . . . .           | 24 |
| <b>Table 13.</b> | Package dimensions . . . . .                                 | 26 |
| <b>Table 14.</b> | Tolerance of form and position . . . . .                     | 26 |
| <b>Table 15.</b> | Document revision history . . . . .                          | 27 |

## List of figures

|                   |  |    |
|-------------------|--|----|
| <b>Figure 1.</b>  | Module block schematic. . . . .                  | 3  |
| <b>Figure 2.</b>  | Teseo-LIV4F module pins layout . . . . .         | 3  |
| <b>Figure 3.</b>  | Module soldering profile graph . . . . .         | 19 |
| <b>Figure 4.</b>  | Module carrier type specifications . . . . .     | 21 |
| <b>Figure 5.</b>  | Module orientation specifications . . . . .      | 21 |
| <b>Figure 6.</b>  | Module cover tape specifications . . . . .       | 22 |
| <b>Figure 7.</b>  | Module plastic reel specifications . . . . .     | 22 |
| <b>Figure 8.</b>  | Module PB band specifications . . . . .          | 23 |
| <b>Figure 9.</b>  | Module labelling information . . . . .           | 24 |
| <b>Figure 10.</b> | LCC-18 (9.7 x 10.1 mm) package outline . . . . . | 25 |

**IMPORTANT NOTICE – READ CAREFULLY**

STMicroelectronics NV and its subsidiaries (“ST”) reserve the right to make changes, corrections, enhancements, modifications, and improvements to ST products and/or to this document at any time without notice.

In the event of any conflict between the provisions of this document and the provisions of any contractual arrangement in force between the purchasers and ST, the provisions of such contractual arrangement shall prevail.

The purchasers should obtain the latest relevant information on ST products before placing orders. ST products are sold pursuant to ST’s terms and conditions of sale in place at the time of order acknowledgment.

The purchasers are solely responsible for the choice, selection, and use of ST products and ST assumes no liability for application assistance or the design of the purchasers’ products.

No license, express or implied, to any intellectual property right is granted by ST herein.

Resale of ST products with provisions different from the information set forth herein shall void any warranty granted by ST for such product.

If the purchasers identify an ST product that meets their functional and performance requirements but that is not designated for the purchasers’ market segment, the purchasers shall contact ST for more information.

ST and the ST logo are trademarks of ST. For additional information about ST trademarks, refer to [www.st.com/trademarks](http://www.st.com/trademarks). All other product or service names are the property of their respective owners.

Information in this document supersedes and replaces information previously supplied in any prior versions of this document.

© 2026 STMicroelectronics – All rights reserved